

Assembly Instructions

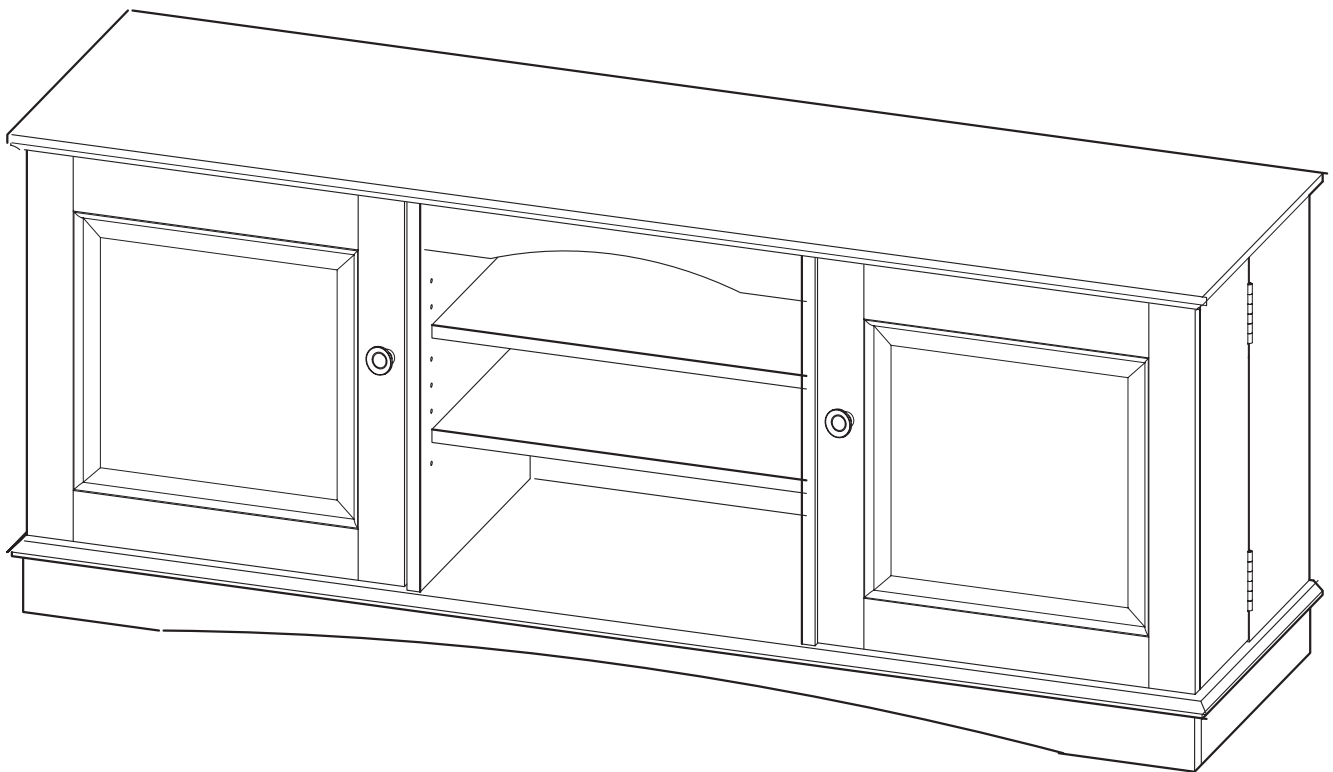

For our most current instructions, to request missing, lost or broken parts, or for any other Customer Service issues, please visit our website.

General Assembly Guidelines

- I. Ensure that all parts and hardware are available before beginning assembly.
- II. Follow each step carefully to ensure the proper assembly of this product.
- III. Two people are recommended for ease in the assembly of this product.
- IV. The four main types of hardware used to assemble this product are: wood dowels, cam bolts and locks, bolts and screws.
- V. The provided glue is to secure wood dowels in place. When first inserting dowels, locate the appropriate hole for the dowel, place a small amount of glue in the hole and insert the dowel. Wipe away excess glue immediately.

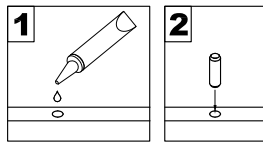

In future assembly steps when dowels are necessary to attach assembly parts together, place a small amount of glue on the end of the dowel before attaching parts together. Wipe away excess glue immediately.

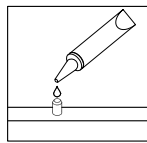

- VI. A Phillips head screwdriver is required for the assembly of this product.

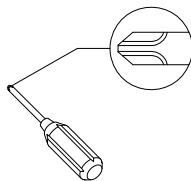



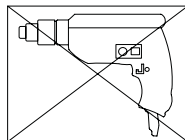



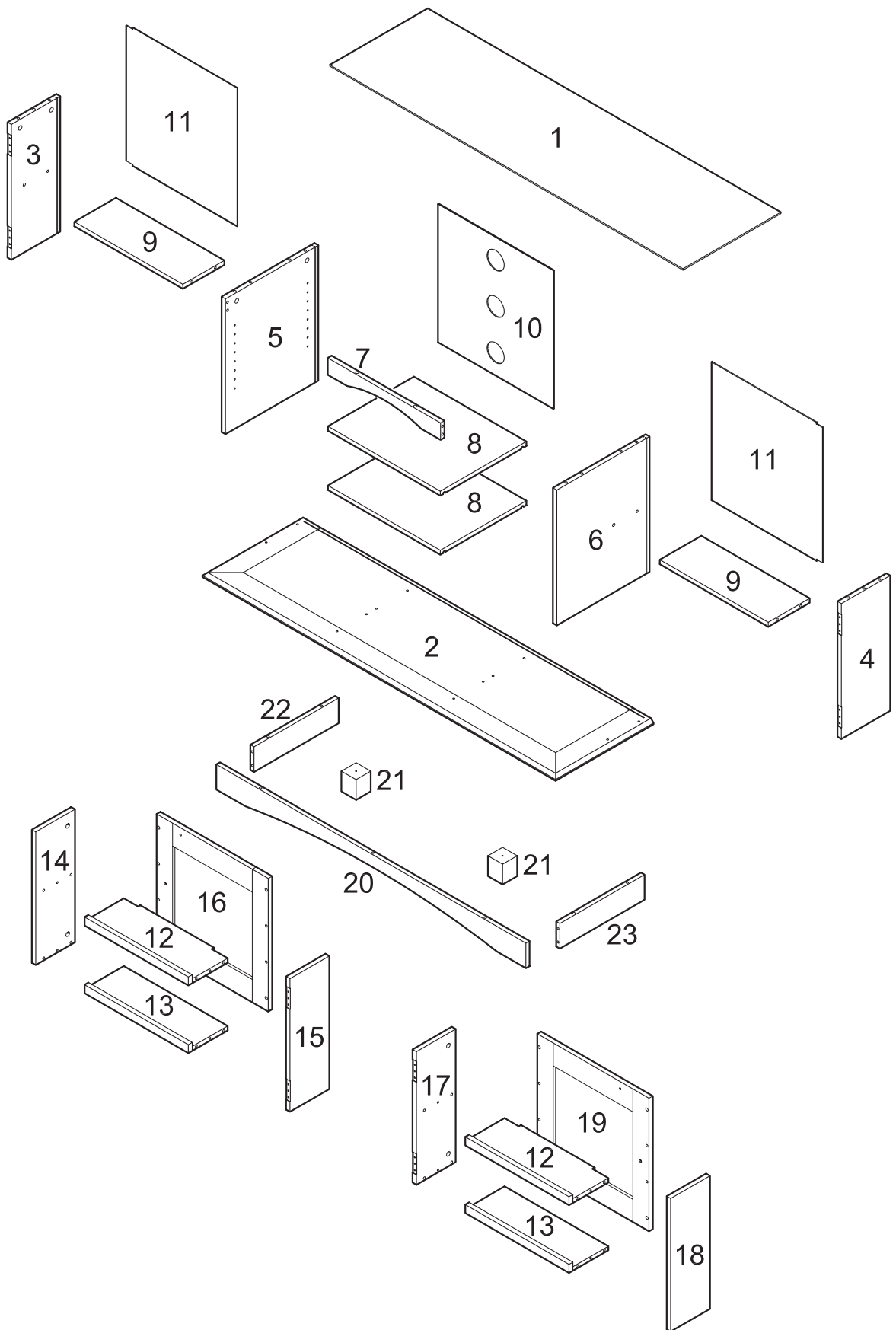



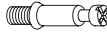





- VII. Power tools should not be used to assemble this product.

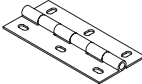

Parts List

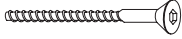

Hardware List

A		Ø8x30mm	Wood dowel	45 pcs
B		Ø6x35mm	Cam bolt	34 pcs
C		Ø15x12mm	Cam lock	34 pcs
D			Door stopper	2 pcs
E		Ø3x15mm	Medium screw	4 pcs
F		32x32mm	Door stopper plate	2 pcs
G		Ø3x12mm	Small screw	2 pcs
H		Ø25x17mm	Handle	2 pcs
J		Ø4x19mm	Small bolt	2 pcs
K		83x23x2mm	Door hinge	4 pcs
L		Ø4x20mm	Extra-large screw	24 pcs
M		Ø5x15mm	Shelf support pin	8 pcs
N			Plastic wedge	12 pcs
P		Ø3x17mm	Large screw	12 pcs
Q		Ø6x50mm	Large bolt	12 pcs
R		Ø4mm	Wrench	1 pc
S			Glue tube	3 pcs
T		Ø25mm	Sticker	34 pcs

*The hardware quantities listed above are required for proper assembly.
Some extra hardware may also have been included.*

Step 1

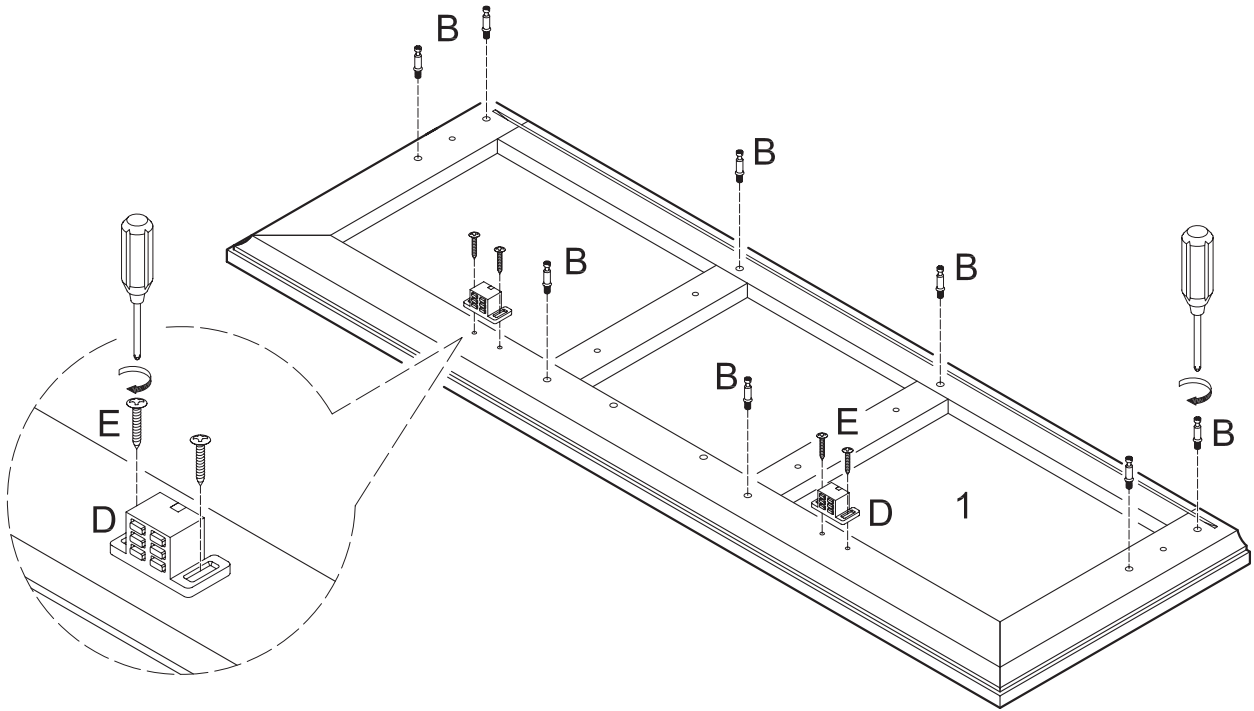

Screw cam bolts (B) into stand top (1). Attach door stoppers (D) to stand top (1) using medium screws (E).

Step 2

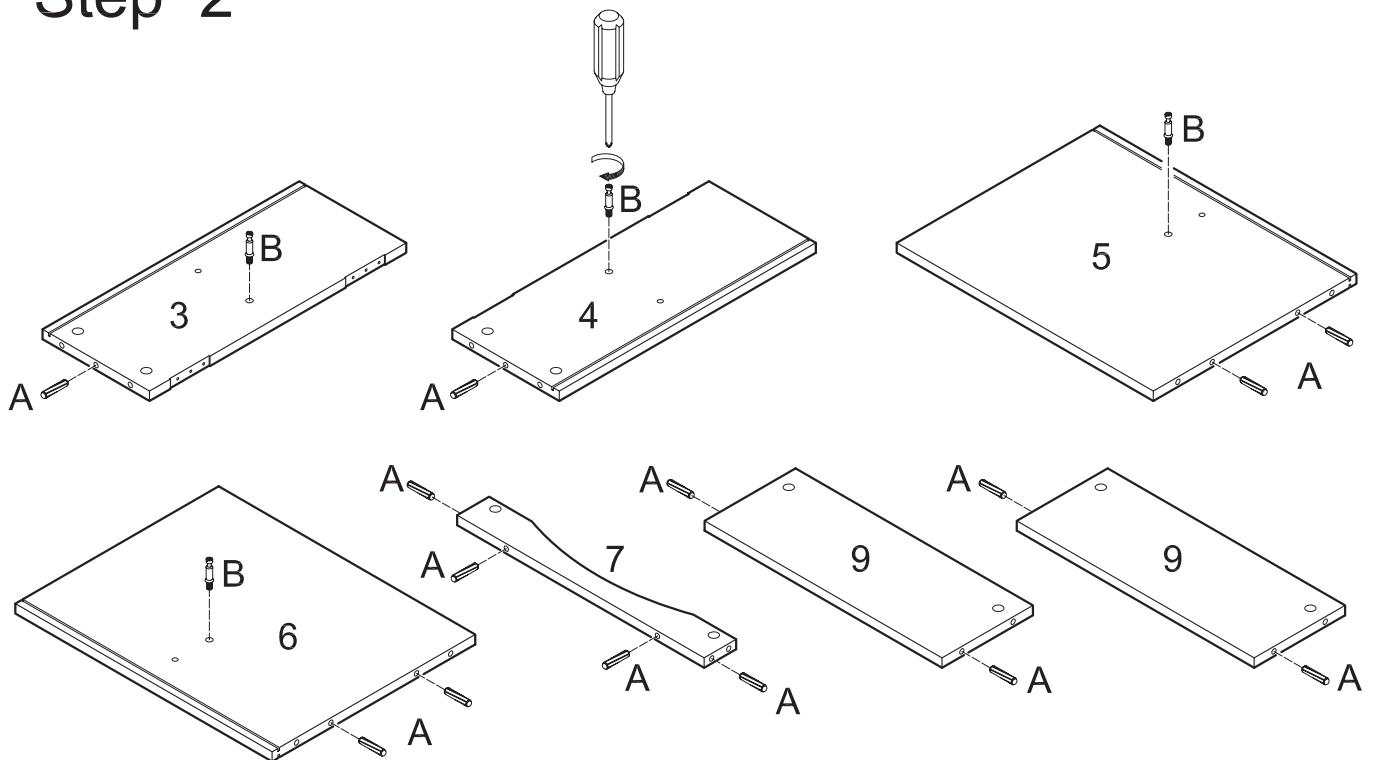

Screw cam bolts (B) into panels (3,4,5,6). Insert dowels (A) into panels (3,4,5,6), slat (7) and shelves (9).

Step 3

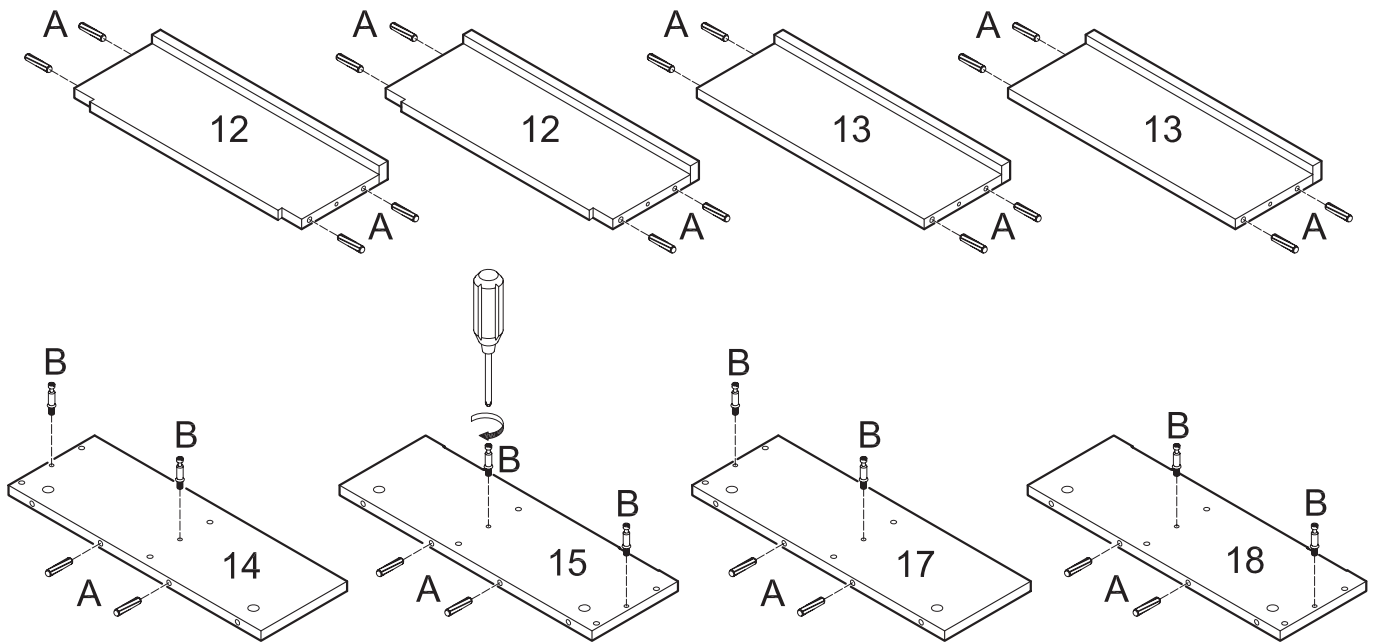

Screw cam bolts (B) into panels (14,15,17,18). Insert dowels (A) into panels (14,15,17,18) and shelves (12,13).

Step 4

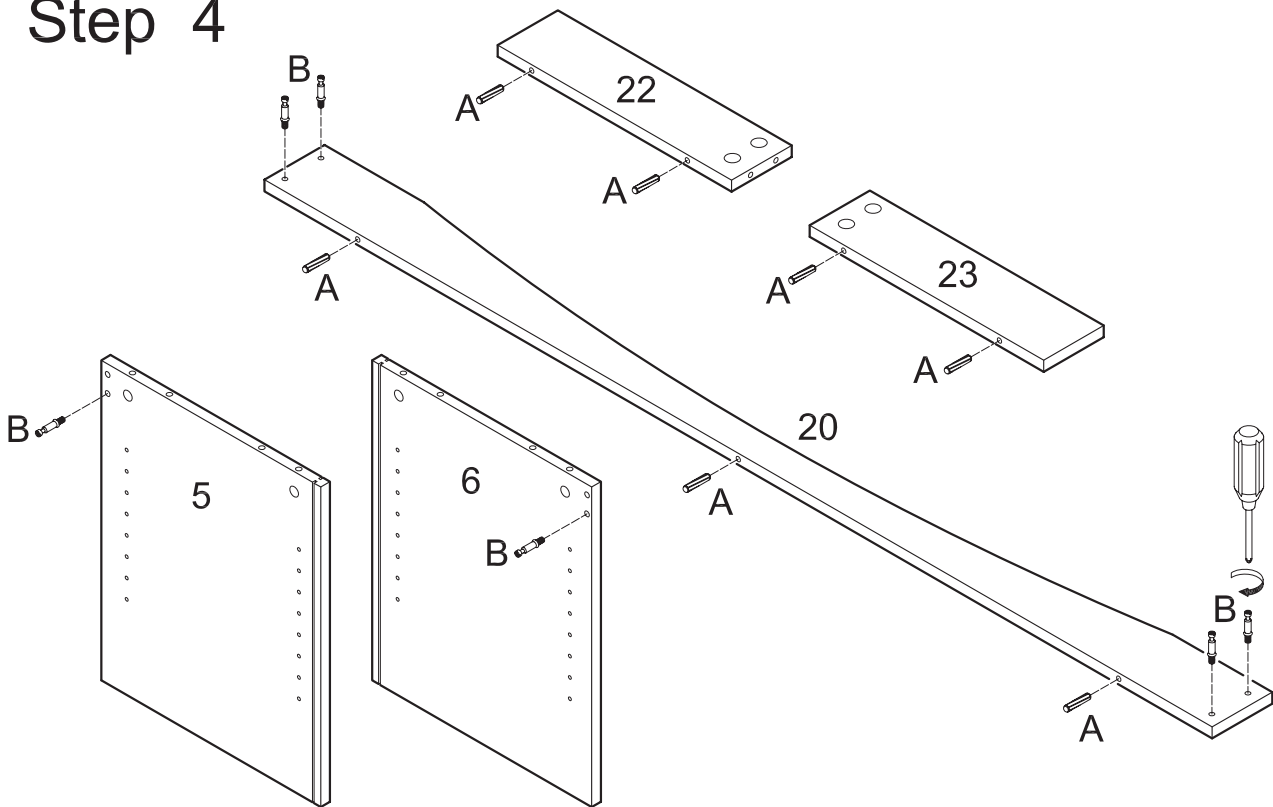

Screw cam bolts (B) into panels (5,6) and slat (20). Insert dowels (A) into slats (20,22,23).

Step 5

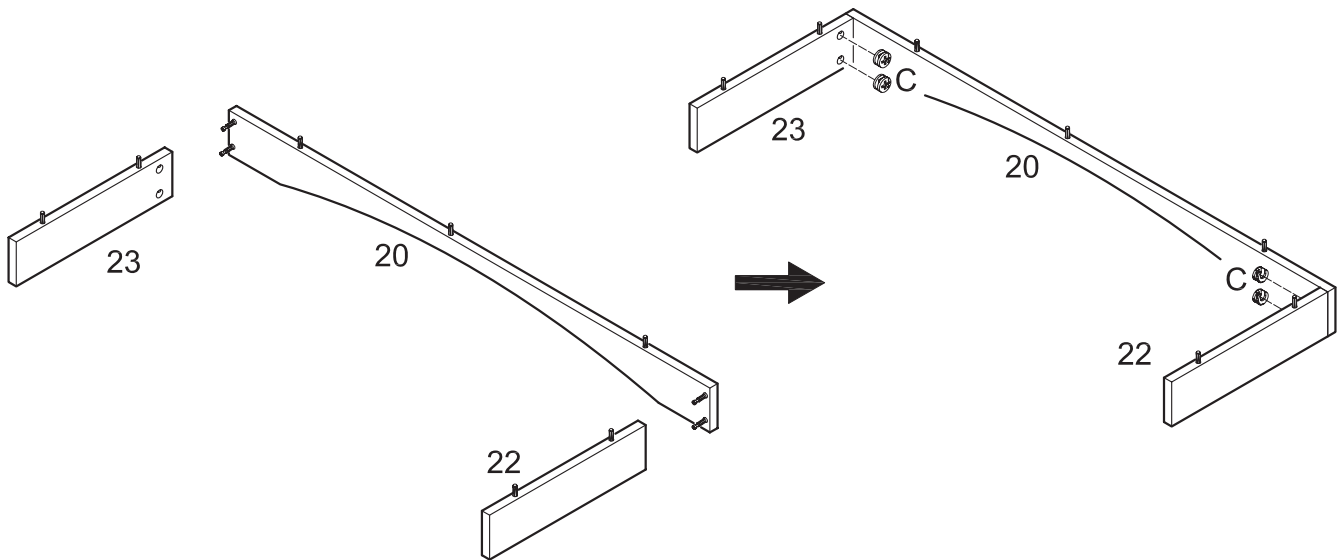
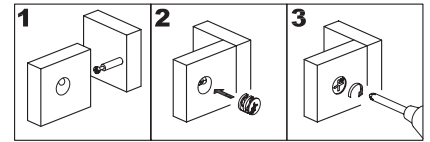

Attach slats (22,23) to slat (20) using cam bolts as guides. Insert cam locks (C) into slats (22,23) and tighten with a screwdriver.

Step 6

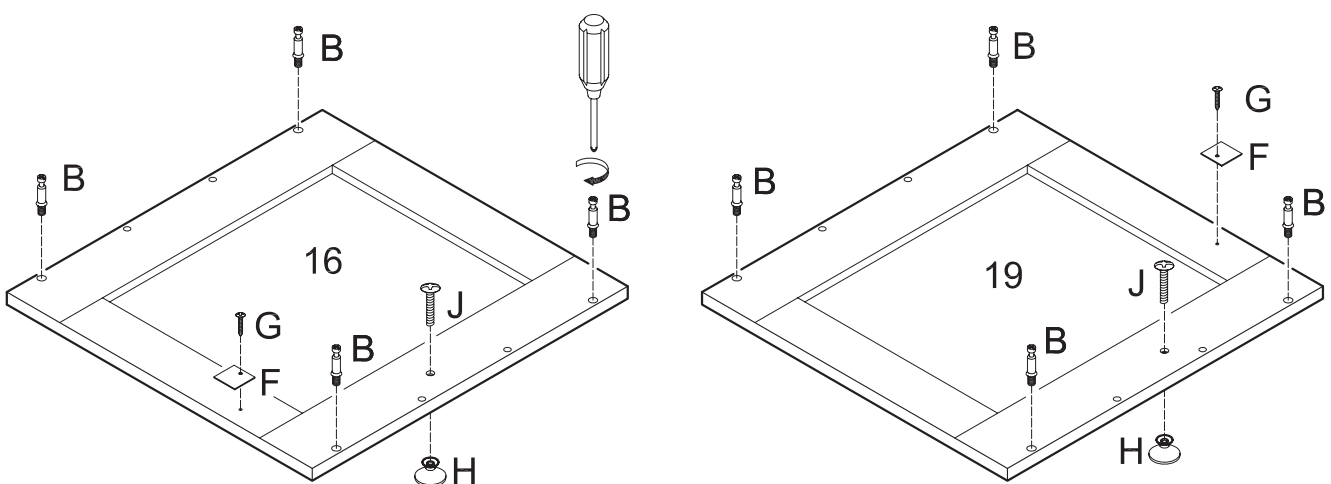

Screw cam bolts (B) into panels (16,19). Attach handles (H) to panels (16,19) using small bolts (J). Attach door stopper plates (F) to panels (16,19) using small screws (G).

Step 7

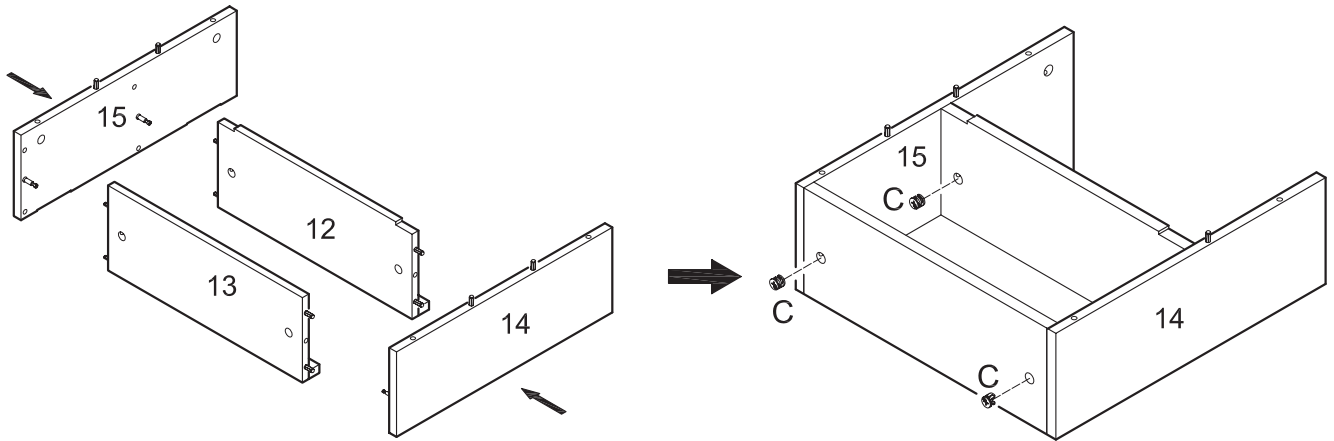
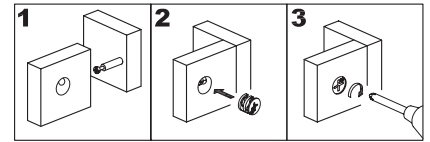

Attach panels (14,15) to shelves (12,13) using cam bolts and dowels as guides. Insert cam locks (C) into shelves (12,13) and tighten with a screwdriver. *Note that two cam locks (C) will be inserted into each shelf (12,13).*

Step 8

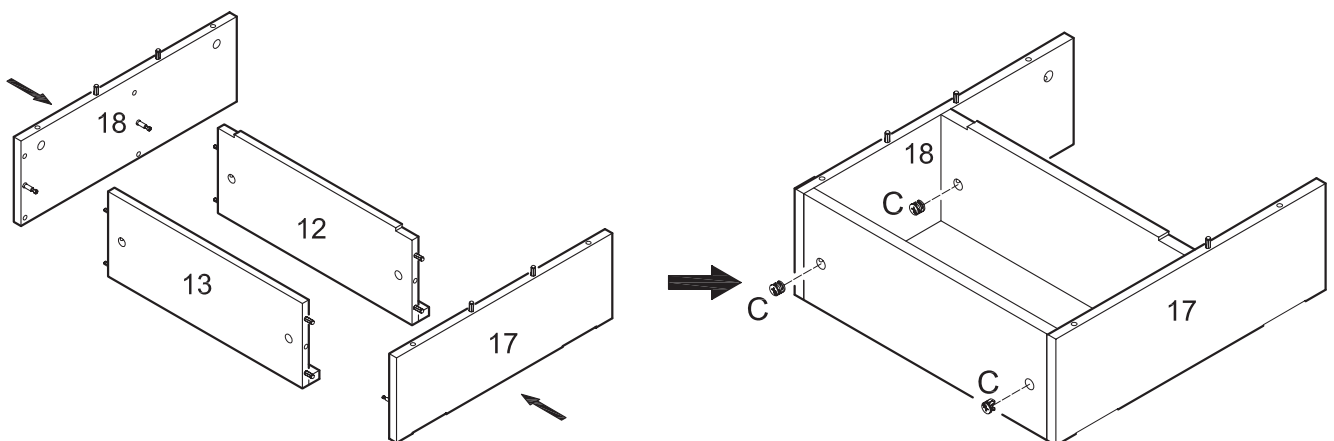
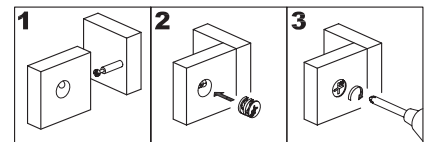

Attach panels (17,18) to shelves (12,13) using cam bolts and dowels as guides. Insert cam locks (C) into shelves (12,13) and tighten with a screwdriver. *Note that two cam locks (C) will be inserted into each shelf (12,13).*

Step 9

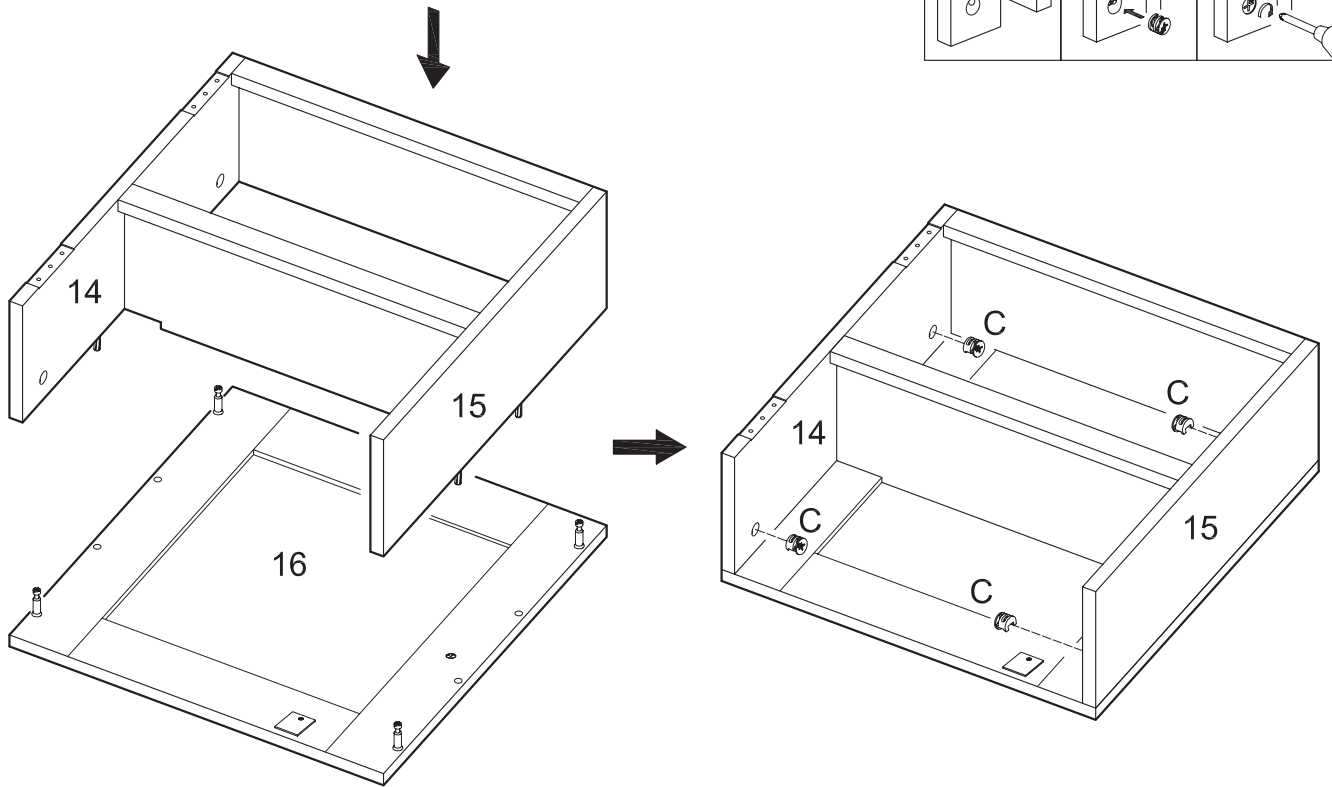

Attach the panel (14,15) assembly to panel (16) using cam bolts and dowels as guides. Insert cam locks (C) into panels (14,15) and tighten with a screwdriver.

Step 10

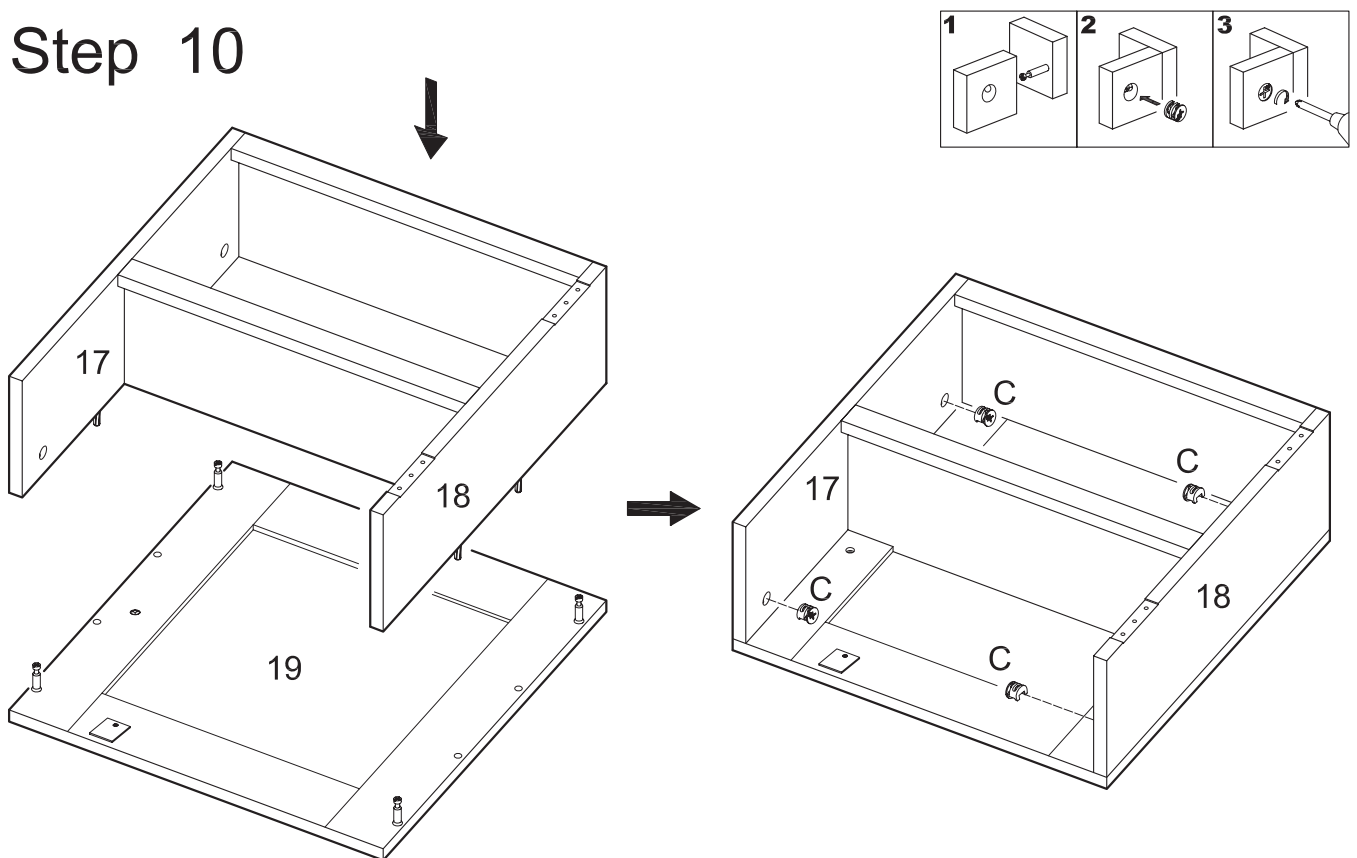

Attach the panel (17,18) assembly to panel (19) using cam bolts and dowels as guides. Insert cam locks (C) into panels (17,18) and tighten with a screwdriver.

Step 11

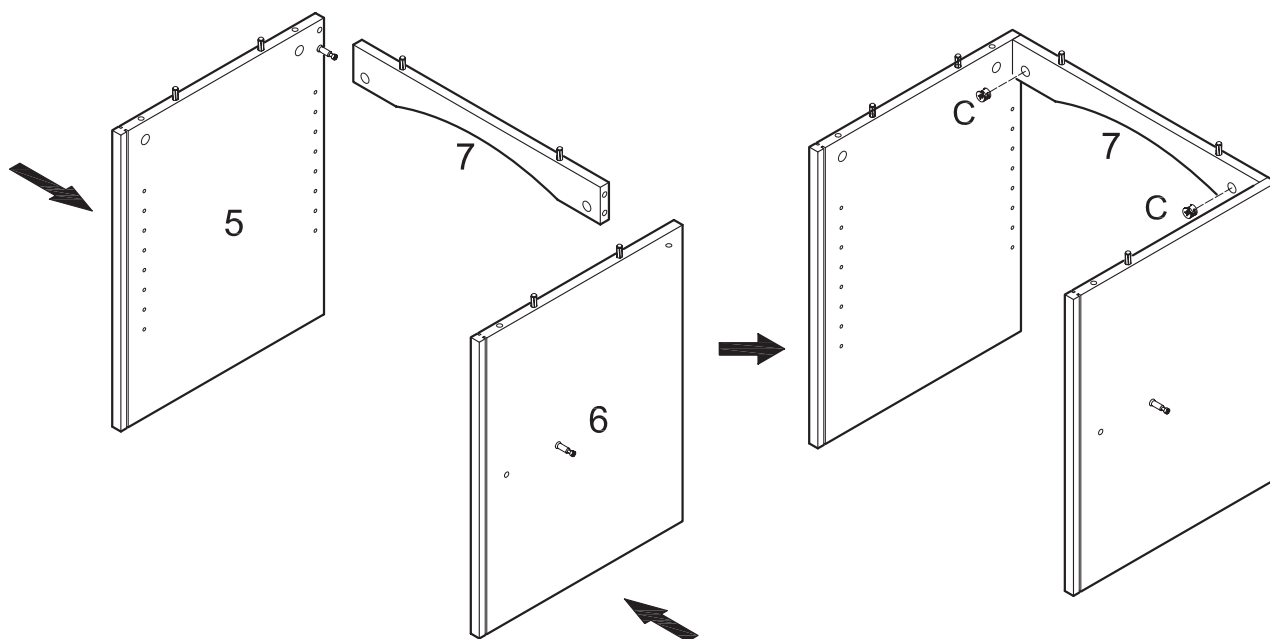
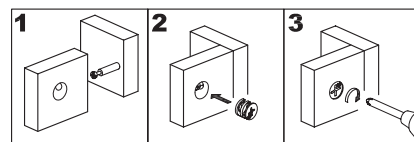

Attach panels (5,6) to slat (7) using cam bolts and dowels as guides. Insert cam locks (C) into slat (7) and tighten with a screwdriver.

Step 12

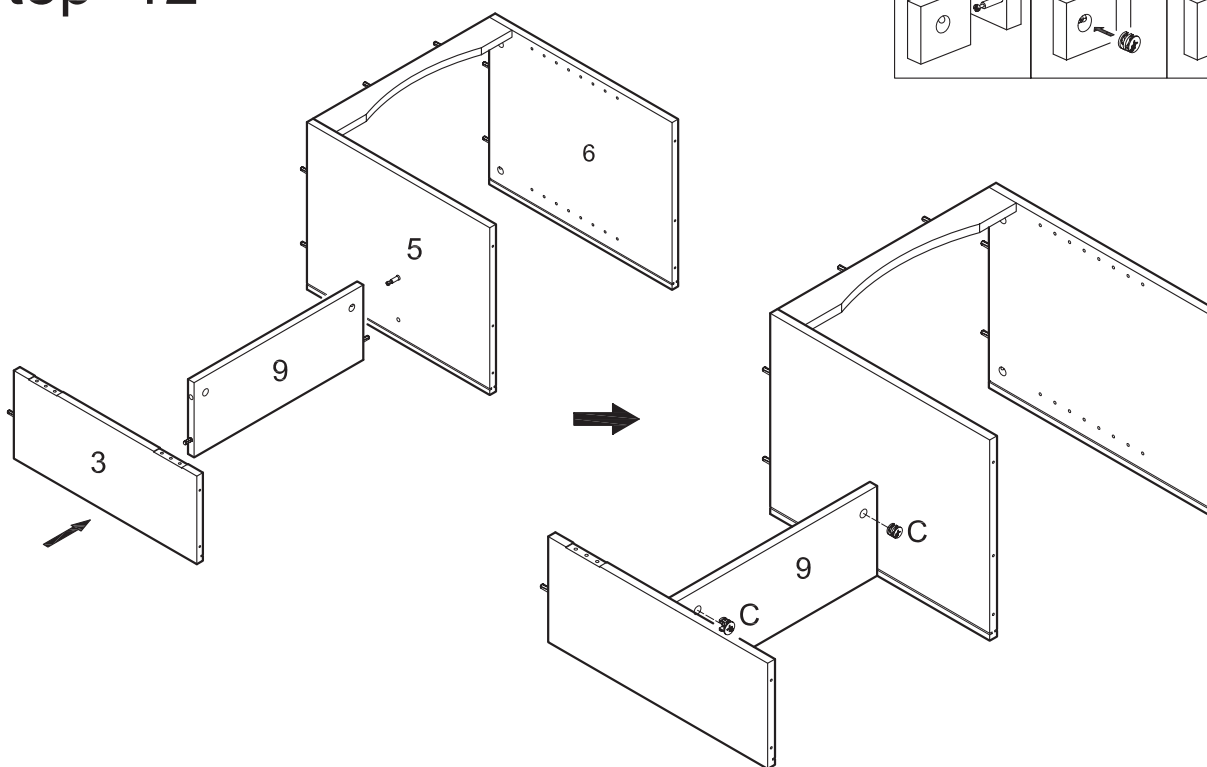
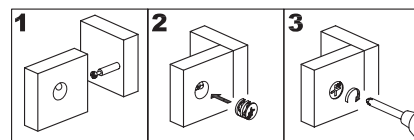

Attach shelf (9) to the panel (5,6) assembly, then attach panel (3) to shelf (9) using cam bolts and dowels as guides. Insert cam locks (C) into shelf (9) and tighten with a screwdriver.

Step 13

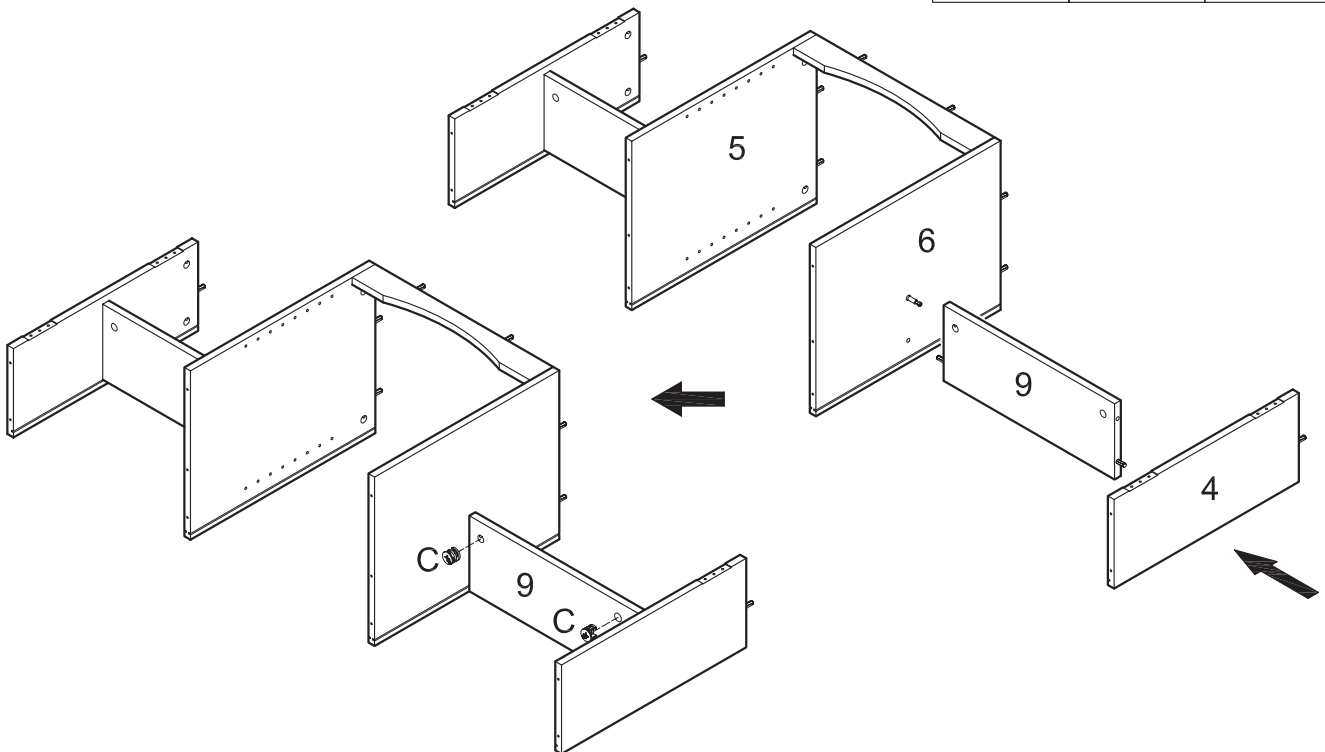
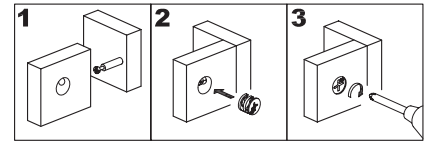

Attach shelf (9) to the panel (5,6) assembly, then attach panel (4) to shelf (9) using cam bolts and dowels as guides. Insert cam locks (C) into shelf (9) and tighten with a screwdriver.

Step 14

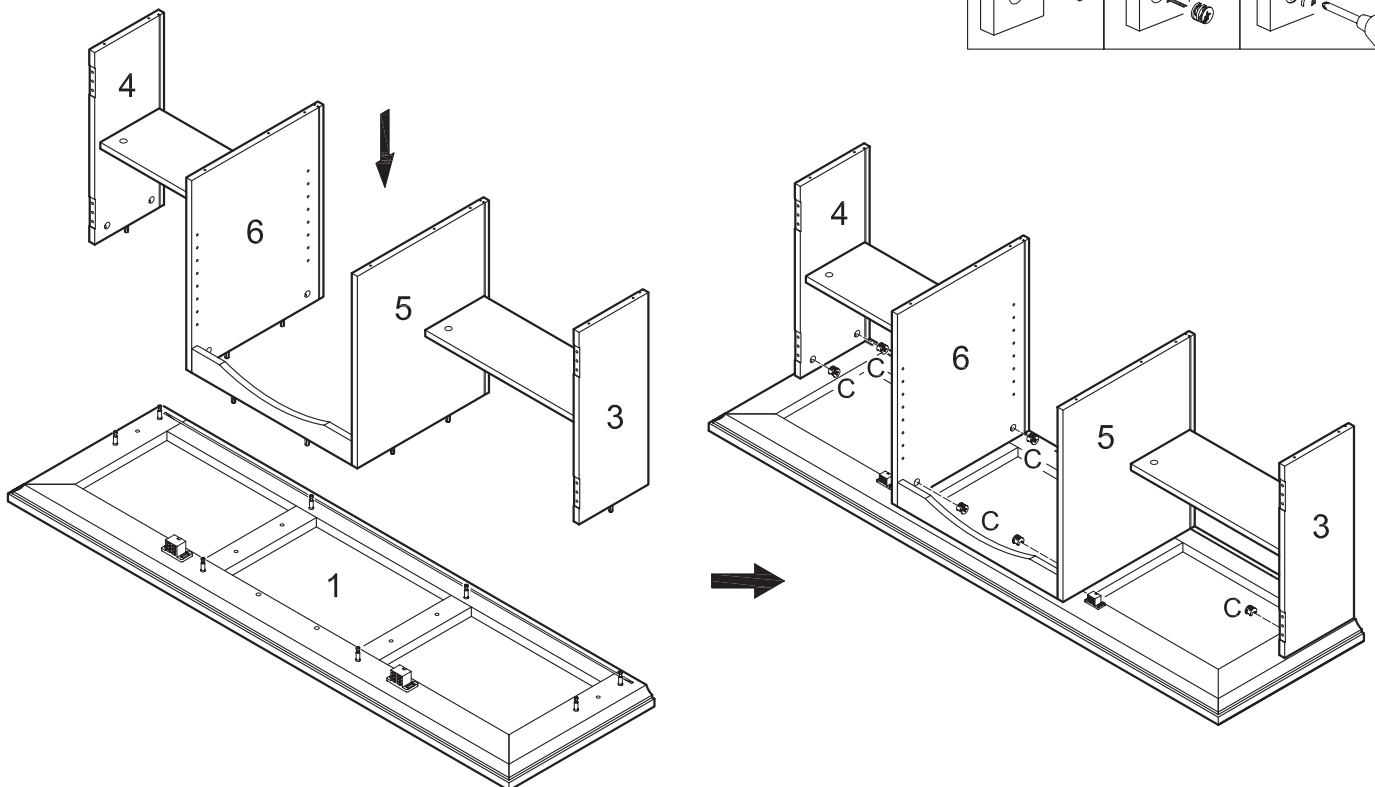
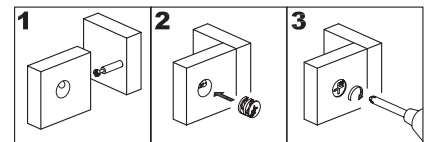

Attach the panel (3,4,5,6) assembly to stand top (1) using cam bolts and dowels as guides. Insert cam locks (C) into panels (3,4,5,6) and tighten with a screwdriver. *Note that two cam locks (C) will be inserted into each panel (3,4,5,6).*

Step 15

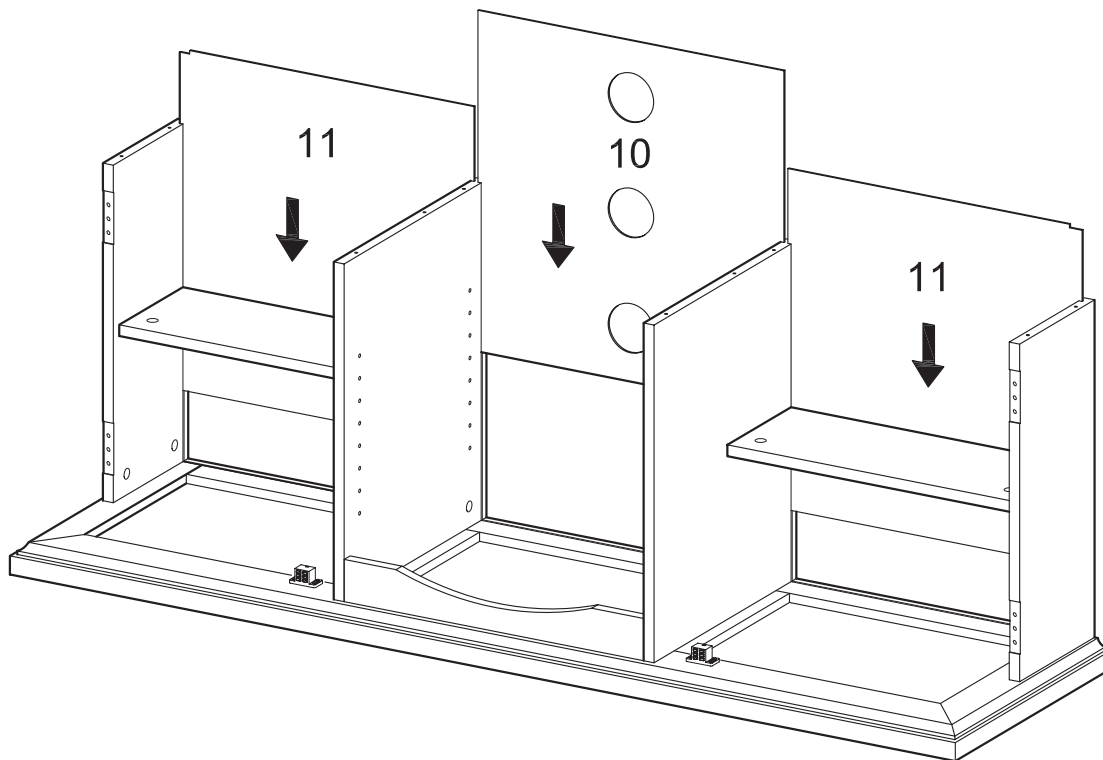

Slide back panels (10,11) into the appropriate grooves at the back of the stand assembly.

Step 16

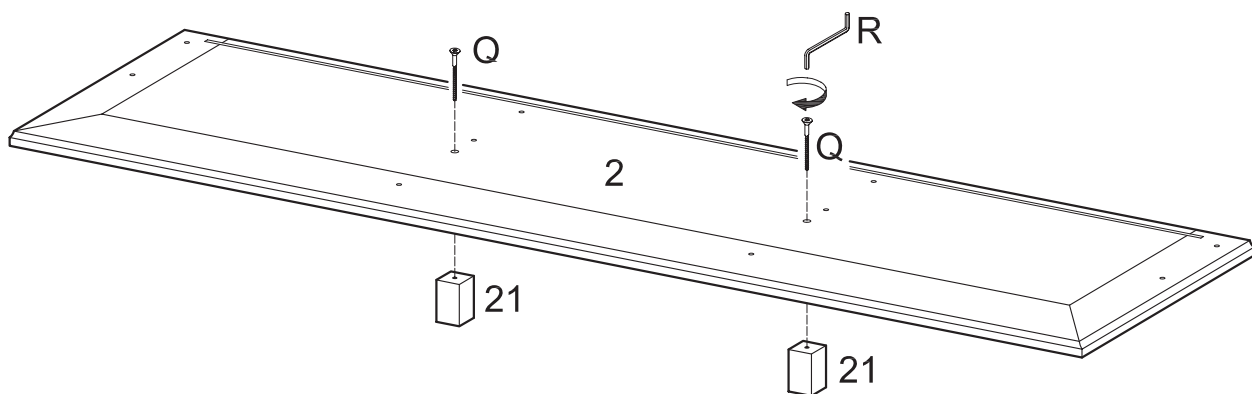

Attach feet (21) to stand base (2) using large bolts (Q) and wrench (R).

Step 17

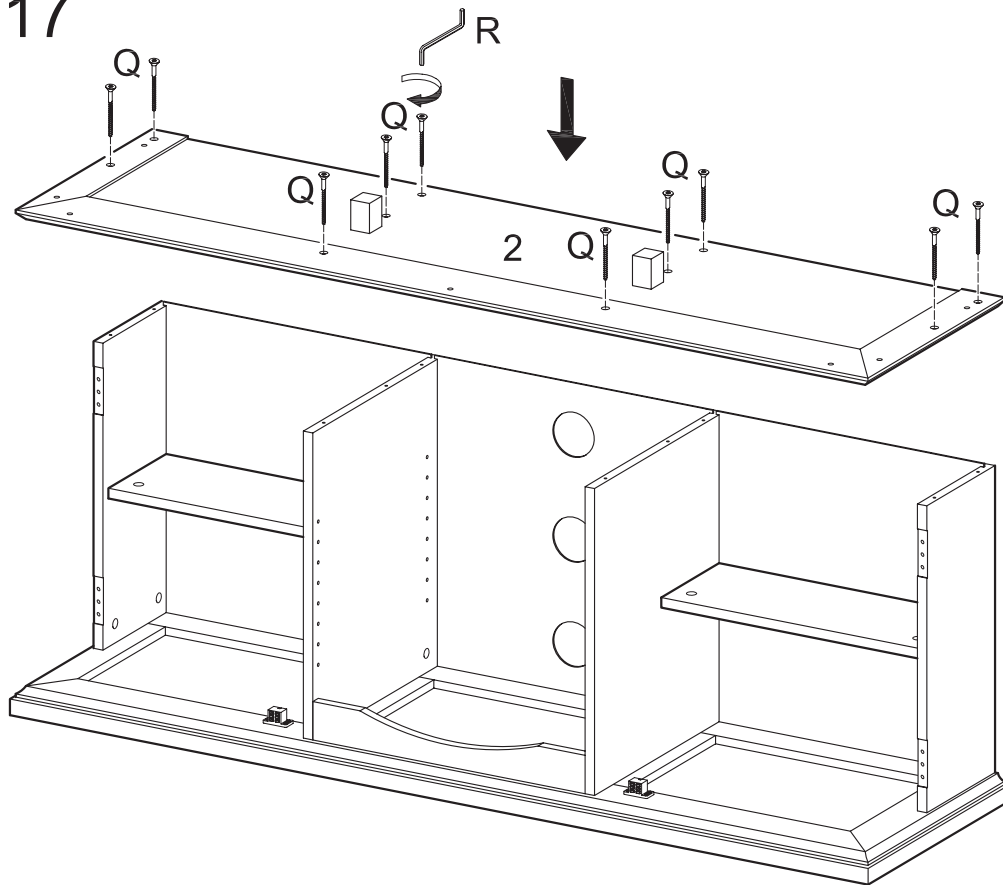

Attach stand base (2) to the stand assembly using large bolts (Q) and wrench (R).

Step 18

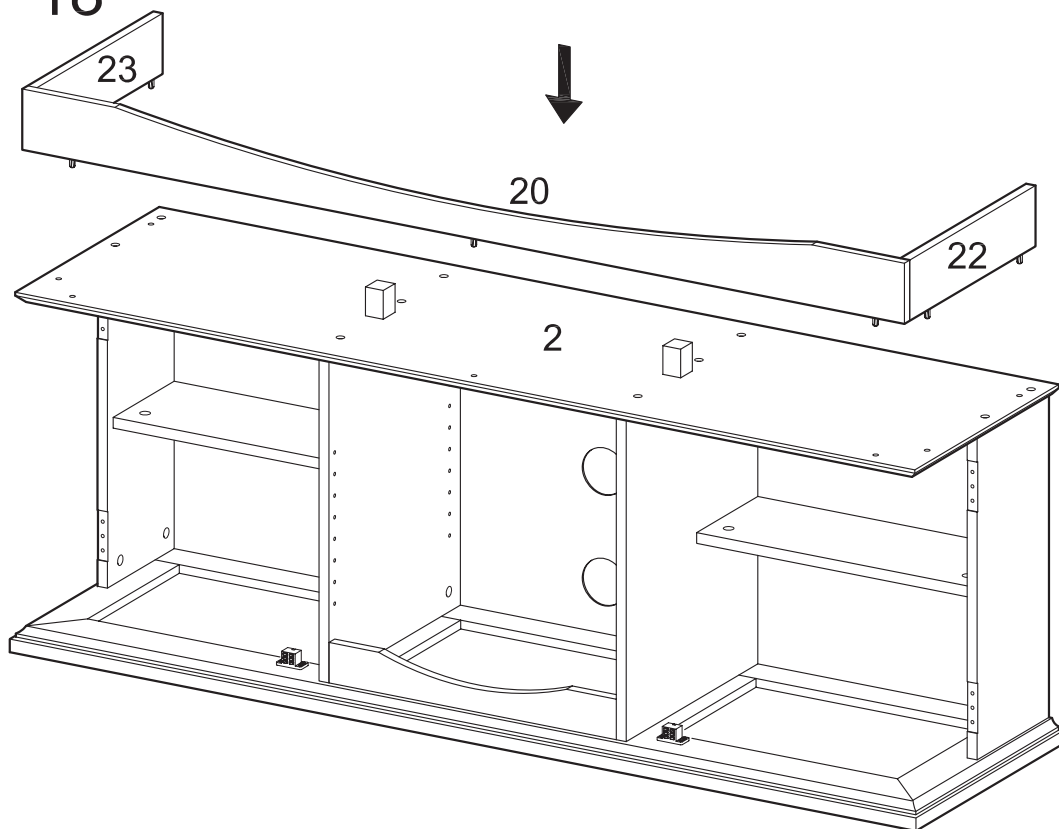

Attach the slat (20,22,23) assembly to stand base (2) using cam bolts and dowels as guides.

Step 19

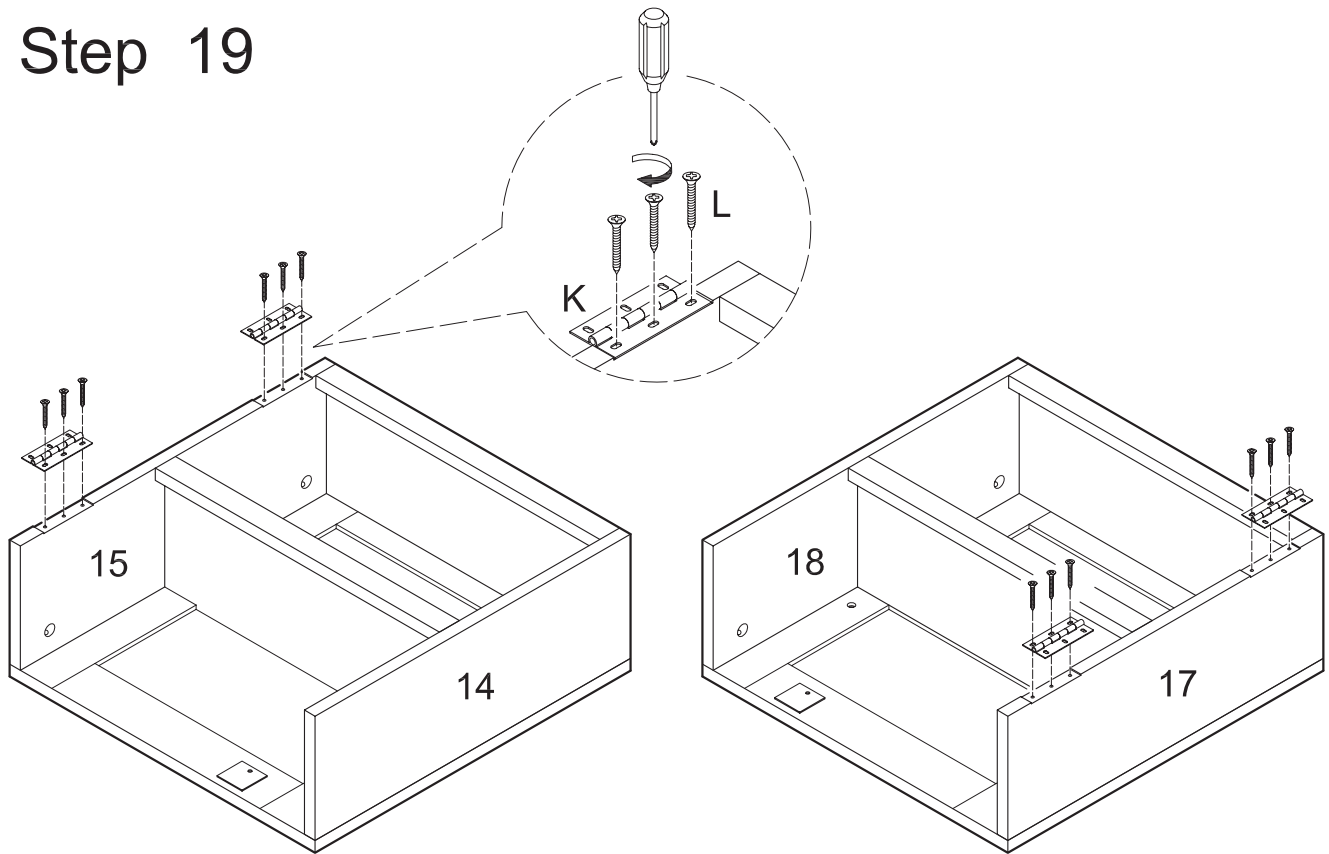

Attach door hinges (K) to panels (15,17) using extra-large screws (L).

Step 20

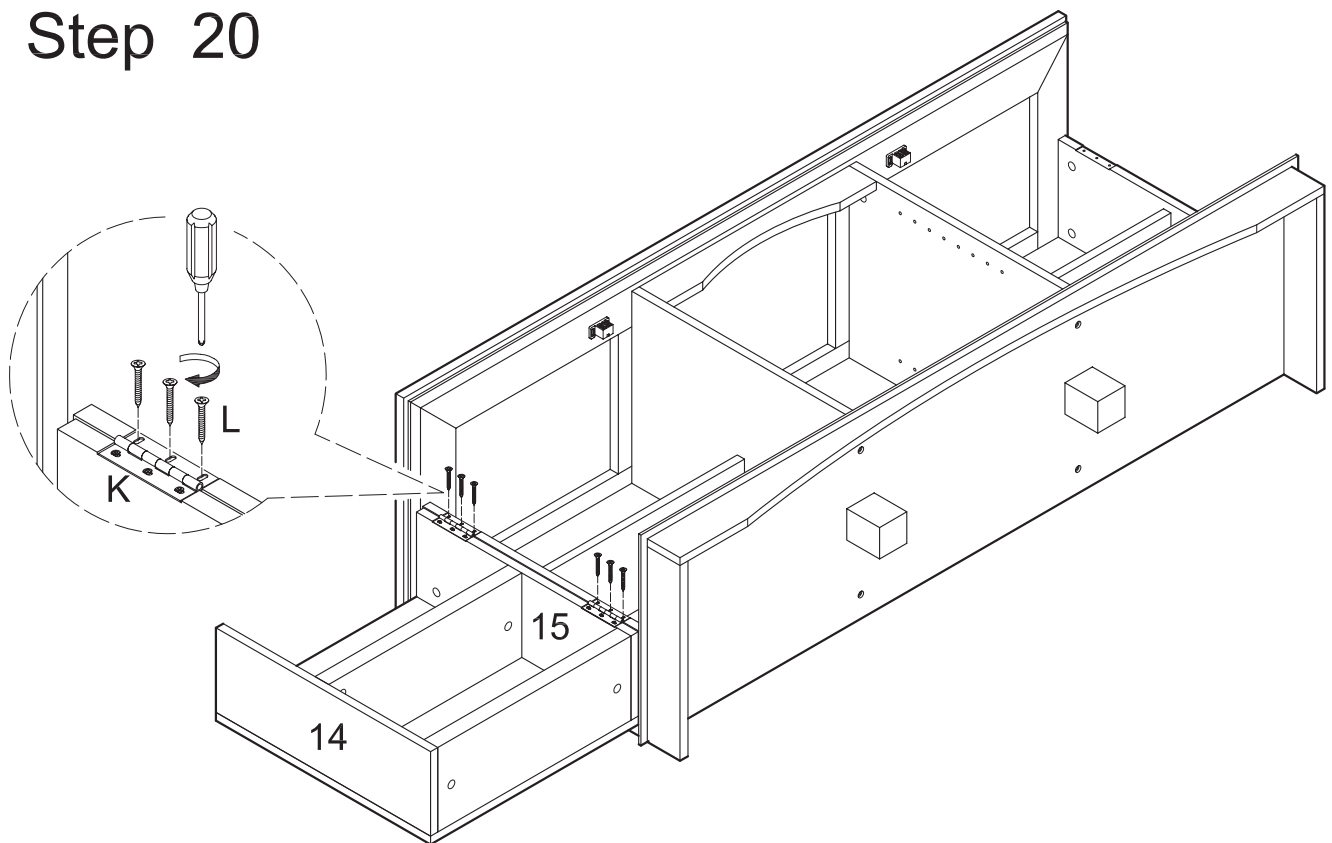

Attach the panel (14,15) assembly to the stand assembly at door hinges (K) using extra-large screws (L).

Step 21

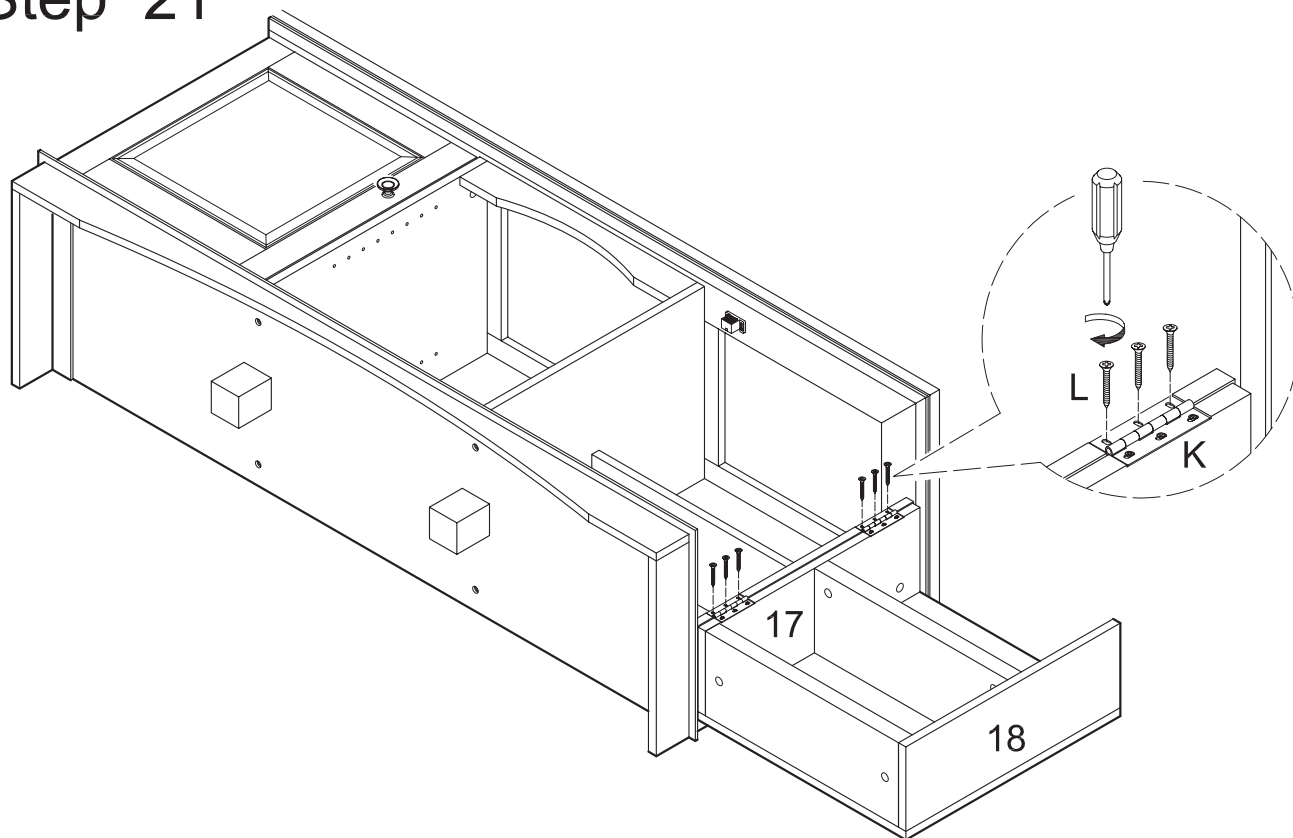

Attach the panel (17,18) assembly to the stand assembly at door hinges (K) using extra-large screws (L).

Step 22

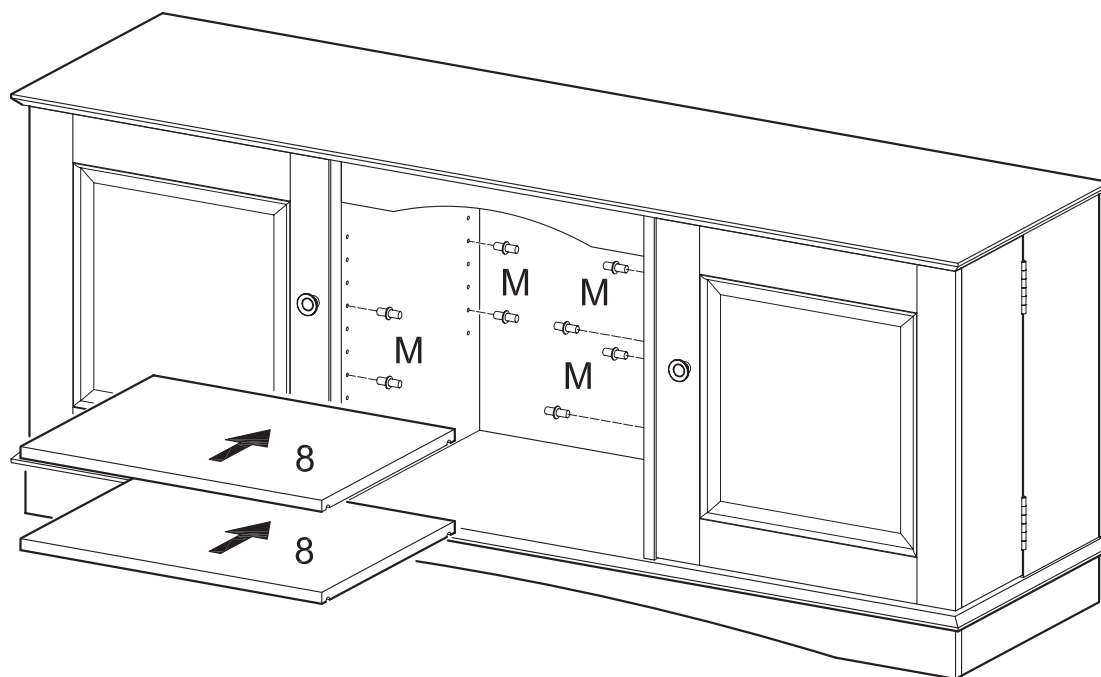

Insert shelf support pins (M) into the stand assembly at desired shelf heights. Carefully place shelves (8) onto shelf support pins (M). *Note that there will be two shelf support pins (M) on either end of each shelf (8).*

Step 23

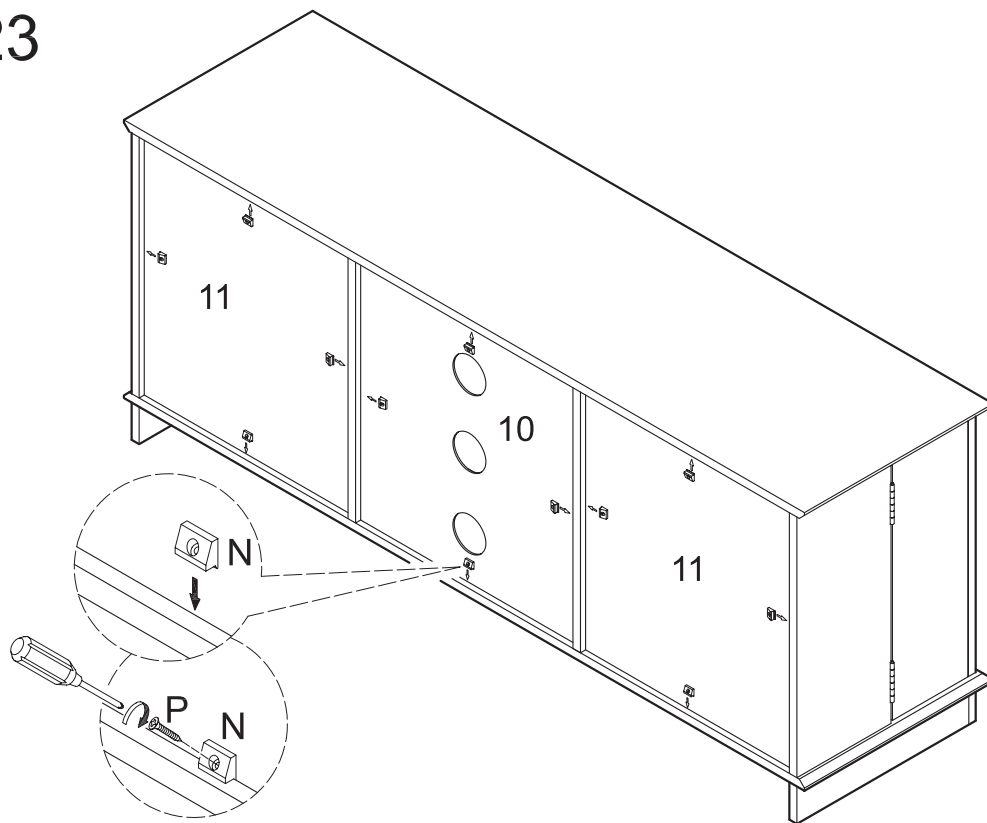

Secure back panels (10,11) using plastic wedges (N) and large screws (P).

Step 24

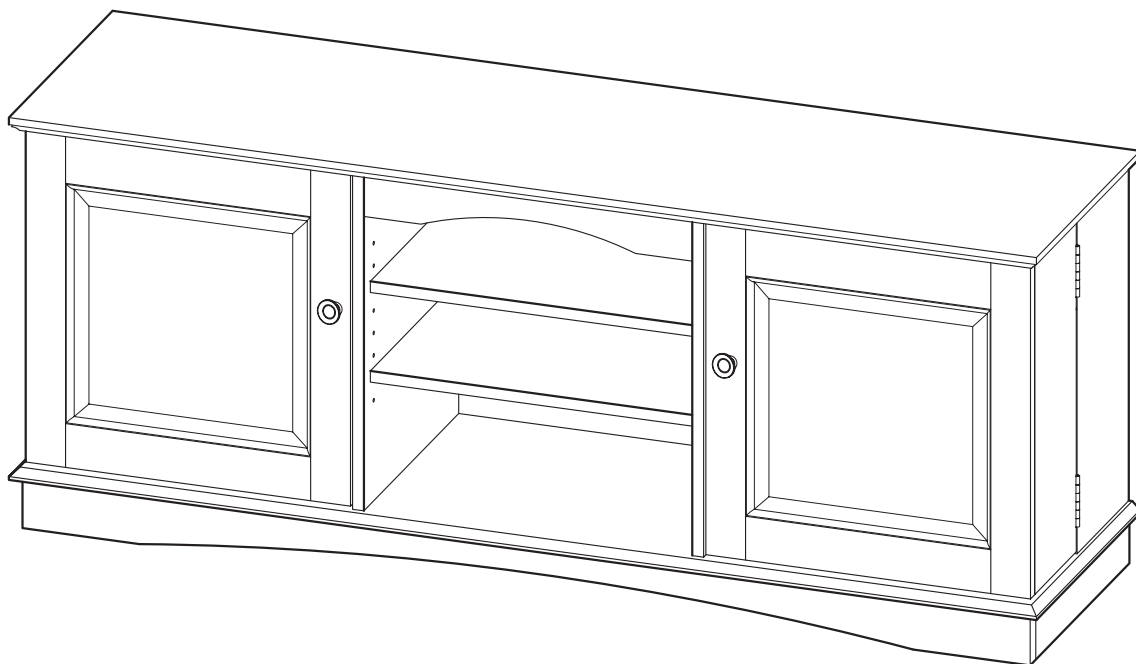

Final Assembly