

**SMALL CABINET
PETITE ARMOIRE
PEQUEÑO ARMARIO**

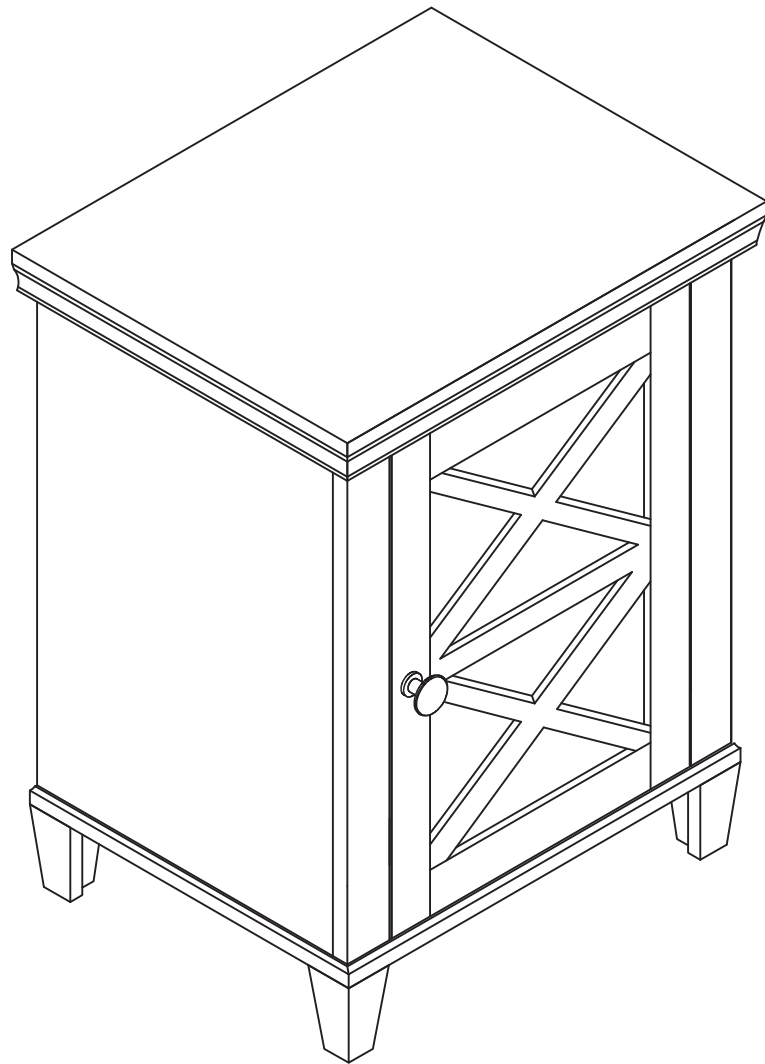

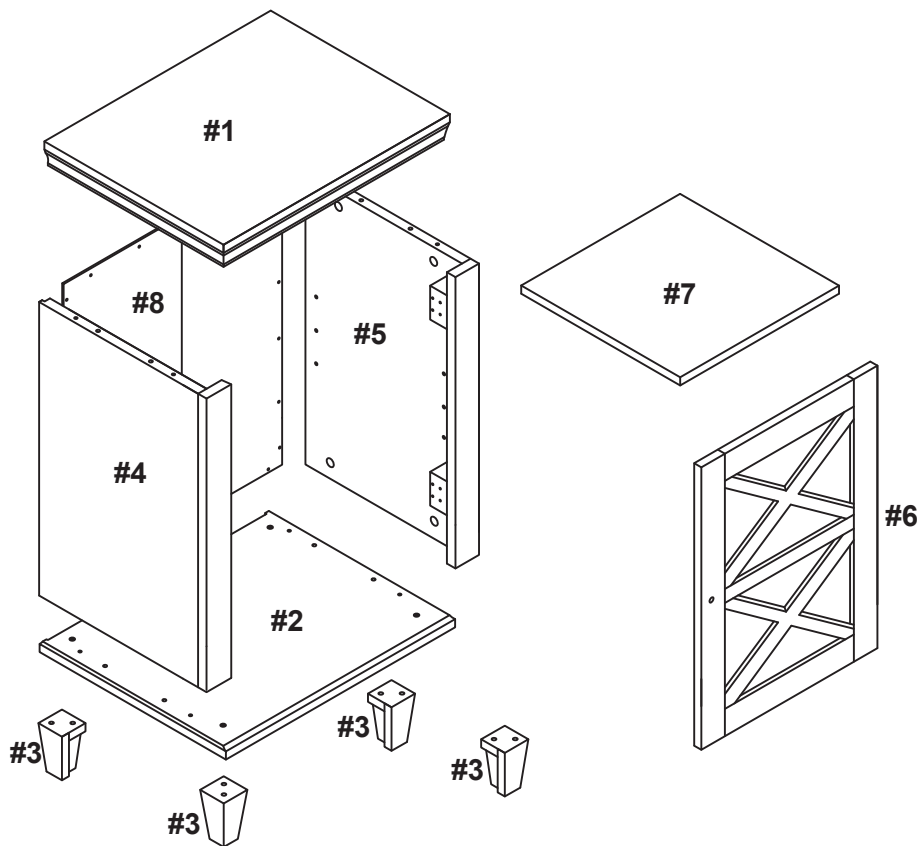



Part list / Liste des pièces / Lista de piezas

#1	Top panel / Panneau supérieur / Panel superior	01
#2	Bottom panel / Panneau inférieur / Panel inferior	01
#3	Leg / Pied / Pata	04
#4	Left panel / Panneau gauche / Panel izquierdo	01
#5	Right panel / Panneau droit / Panel derecho	01
#6	Door / Porte / Puerta	01
#7	Adjustable shelf / Plateau réglable / Estante ajustable	01
#8	Back panel / Panneau arrière / Panel posterior	01

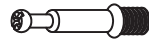

Hardware list / Liste des pièces / Lista de piezas

A	Cam bolt / Pênes battants / Perno de leva		08
B	Cam lock / Serrures batteuses / Traba de leva		08
C	Wood dowel / Goujons de bois / Tarugo de madera		12
D	Bolt (6x35mm) / Boulon / Perno		04

E	Screw (4x14mm) / Vis / Tornillo		12
F	Hinge / Charnières / Bisagra		02
G	Bolt (4x18mm) / Boulon / Perno		01
H	Knob / Bouton / Perilla		01
I	Shelf support / Plateau support / Plataforma de soporte		04
J	Screw (3x12mm) / Vis / Tornillo		18
K	Magnet door stop / Butées pour porte magnétique / Topes magnétiques de puerta		01
L	Screw (3x14mm) / Vis / Tornillo		03
M	Metal plate / Plaque de métal / Placa de metal		01
N	Screw (4x16mm) / Vis / Tornillo		01
O	Screw (4x35mm) / Vis / Tornillo		01
P	Wall anchor / Ancrages muraux / Anclaje de pared		01
Q	Magnet plate / Plaque aimantée / Placa imantada		01

Tools required / Outils requis / Herramientas requeridas

Allen key / Clé hexagonale / Llave allen		Supplied / Fourni / Incluido
Philips screwdriver / Tournevis philips / Destornillador estándar		Not supplied / Non fourni / No incluido

IMPORTANT:

1. Do not tighten bolts completely until all bolts are completely lined up and inserted into holes / nuts.
2. Do not over tighten screws and bolts to avoid stripping.
3. Please use hand tools to assemble this product. Do not use power tools.

IMPORTANT:

1. Ne serrez pas complètement les boulons jusqu'à ce que tous les boulons soient complètement alignés et insérés dans les trous / écrous.
2. Ne pas trop serrer les vis et les boulons pour éviter d'endommager les filets.
3. Utilisez des outils à main pour assembler ce produit. N'utilisez pas d'outils électriques.

IMPORTANTE:

1. No apriete completamente los pernos hasta que todos los tornillos estén alineados completamente y se inserten en los agujeros / tuercas.
2. No apriete demasiado los tornillos y los pernos para evitar dañar los filetes.
3. Utilice herramientas de mano para montar este producto. No utilice herramientas eléctricas.



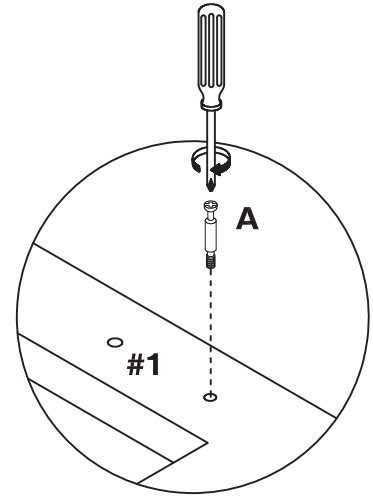
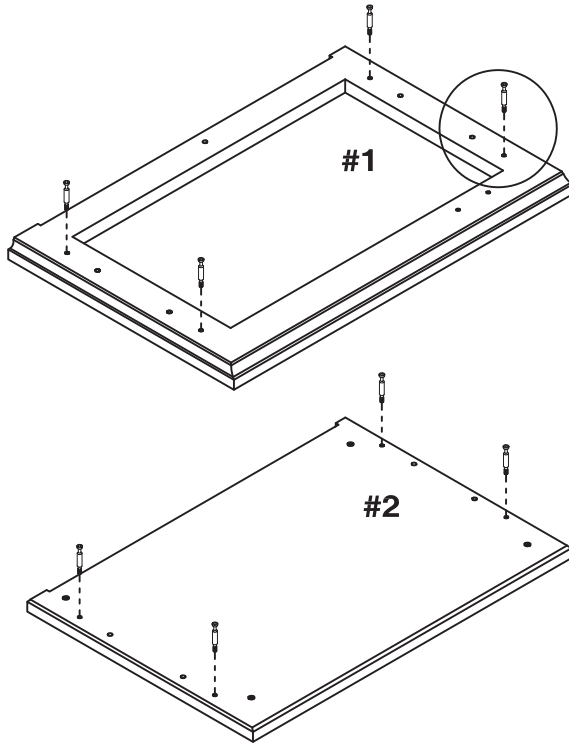

1.

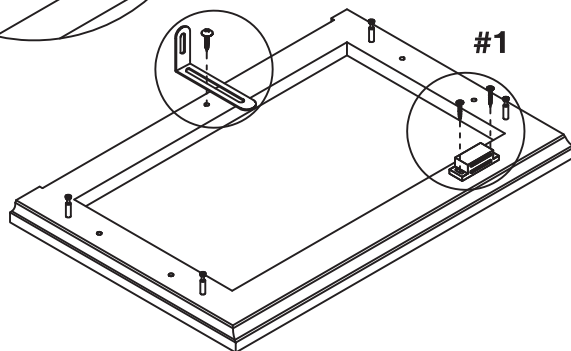
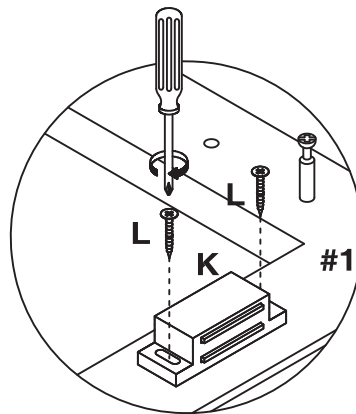
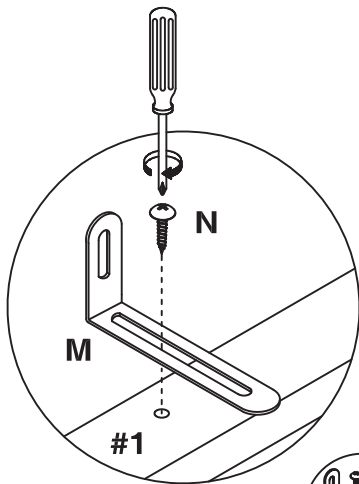

A		08
---	---	----



2.



K		01
L		02
M		01
N		01

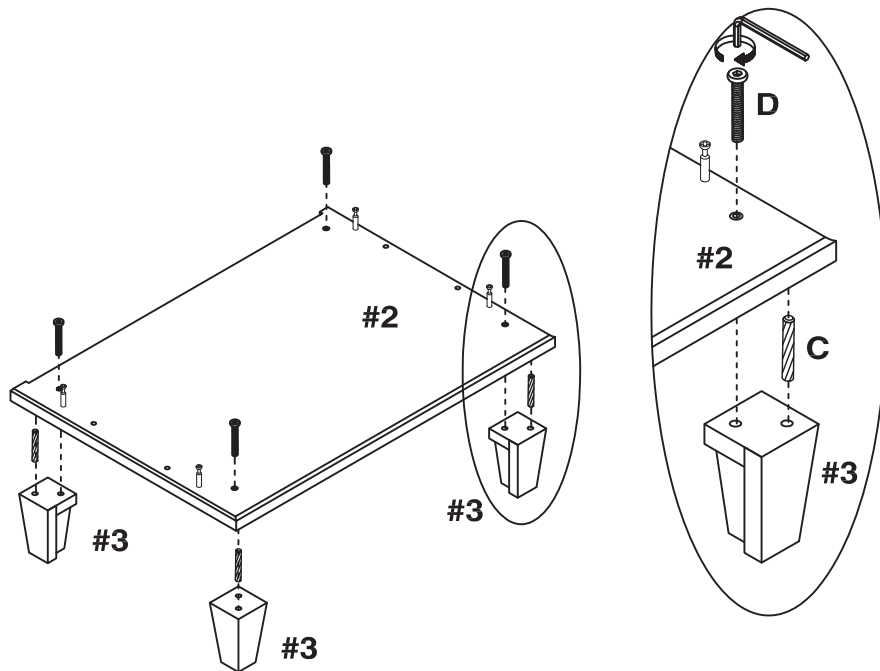

3.

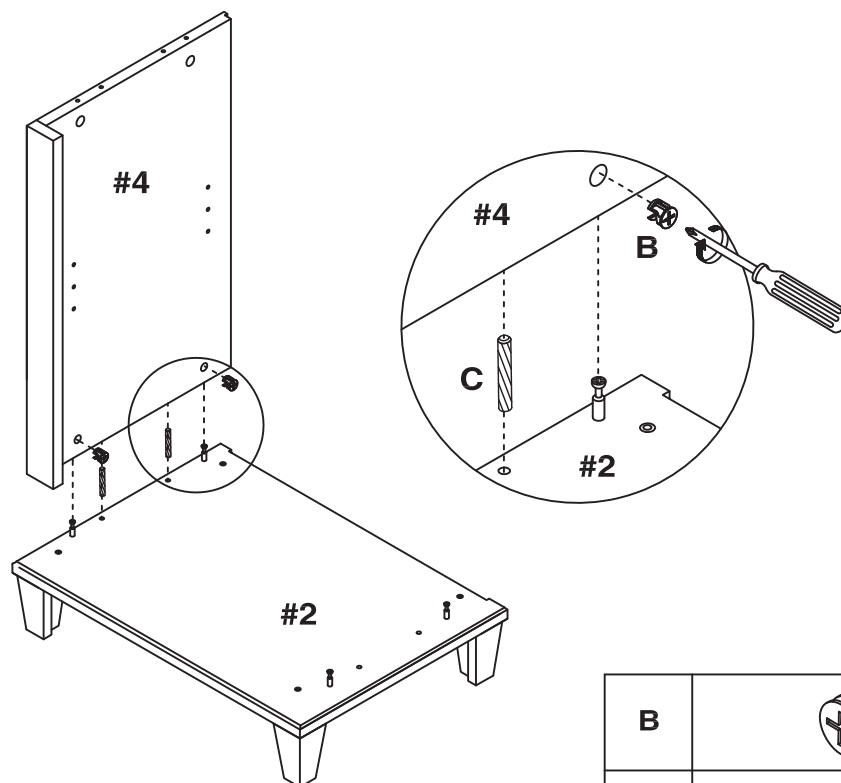

C		04
D		04

4.



B		02
C		02

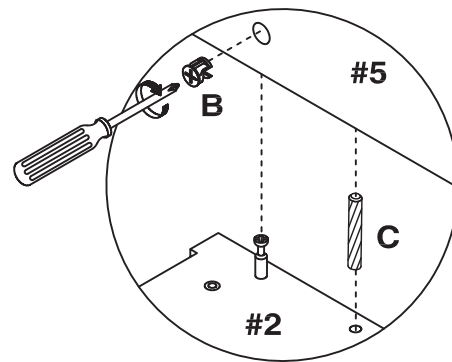
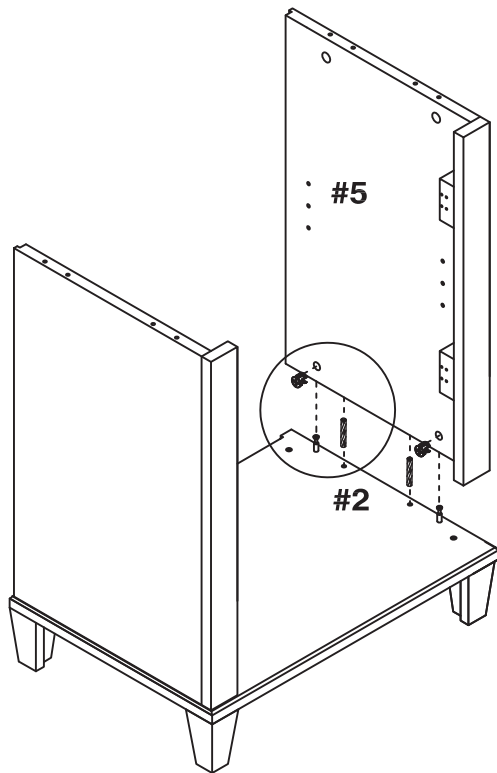

5.

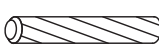

B		02
C		02

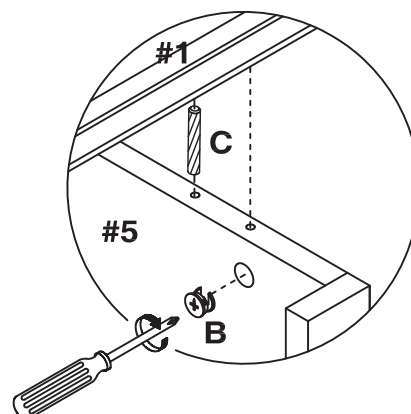
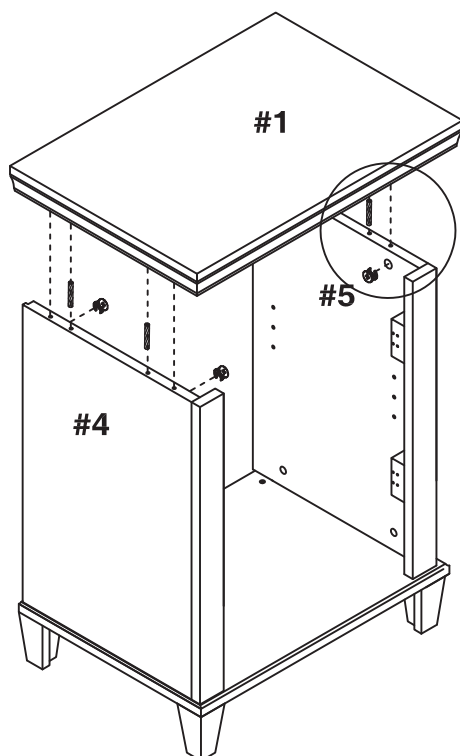



6.

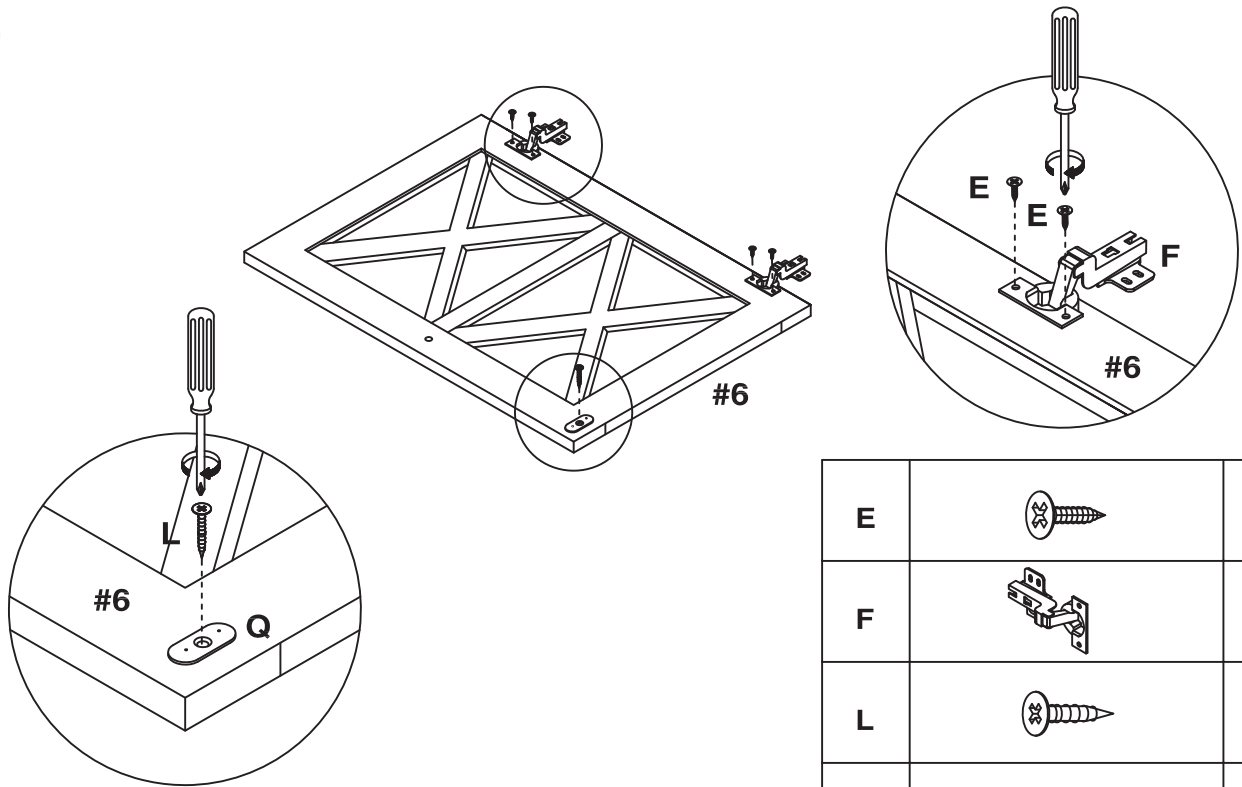

B		04
C		04



7.

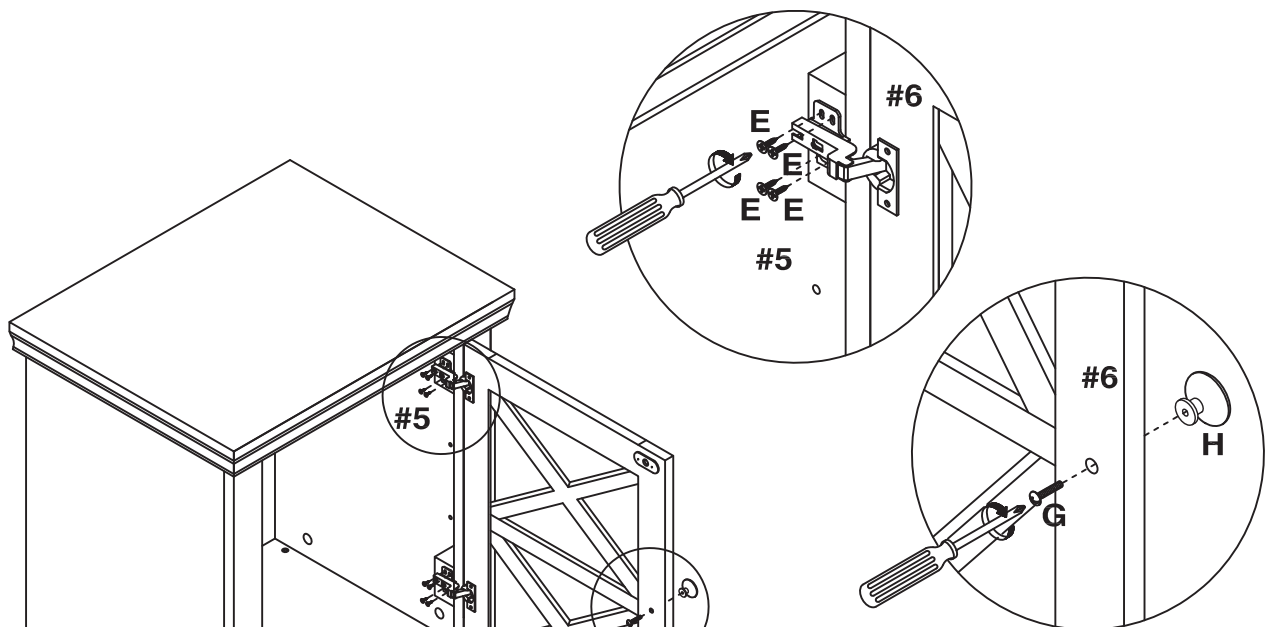

E		04
F		02
L		01
Q		01

8.



E		08
G		01
H		01

9.

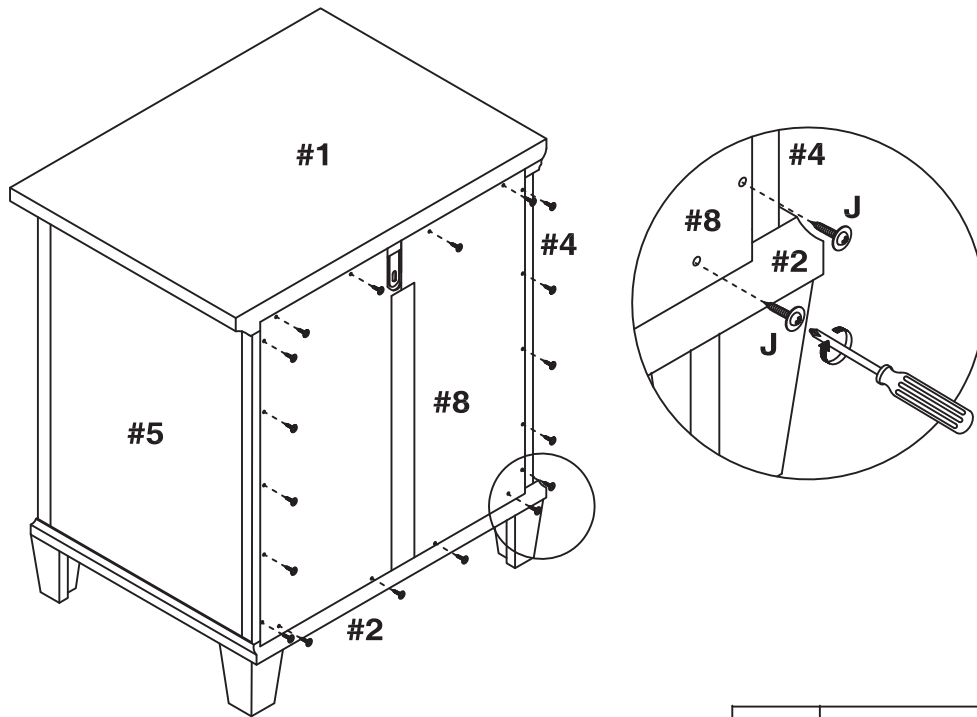

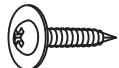
J		18
---	---	----

10.

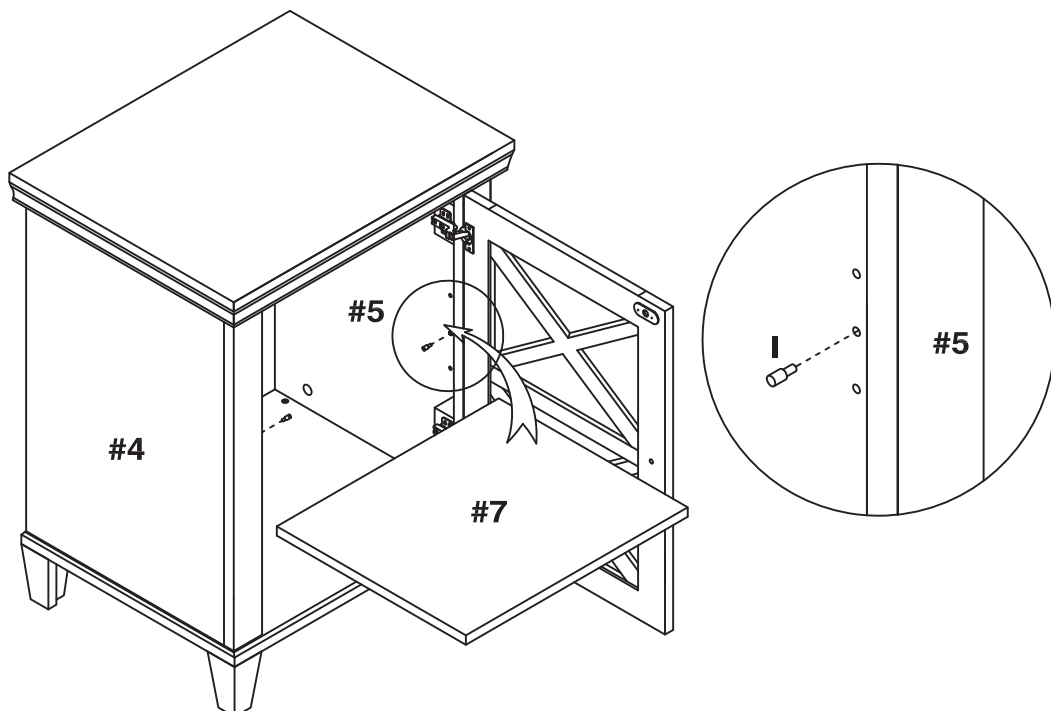

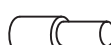
I		04
---	---	----

PLEASE NOTE: For your safety, to prevent the danger of this unit tipping over, it is important that the wall anchors are properly attached.

S'IL VOUS PLAÎT NOTE: Pour votre sécurité, pour éviter le danger de cette unité de basculement, il est important que les chevilles sont correctement fixés.

NOTA: Para su seguridad, para evitar el peligro de esta unidad se vuelque, es importante que los anclajes de pared estén bien fijados.

⚠ WARNING

Serious or fatal crushing injuries can occur from furniture tipover. To help prevent tipover:

- Install tipover restraint provided.
- Place heaviest items in the lower drawers.
- Unless specifically designed to accommodate, do not set TVs or other heavy objects on top of this product.
- Never allow children to climb or hang on drawers, doors or shelves.
- Never open more than one drawer at a time. (OR)
- Do not defeat or remove the drawer interlock system.

Use of tipover restraints may only reduce, but not eliminate, the risk of tipover.

This is a permanent label. Do not remove.

⚠ AVERTISSEMENT

Le basculement du meuble peut causer de graves blessures par écrasement, voire la mort. Pour empêcher le basculement:

- Installer les dispositifs antibasculement fournis.
- Ranger les articles les plus lourds dans les tiroirs du bas.
- À moins qu'il ne soit conçu à cette fin, éviter de placer un téléviseur ou un objet lourd sur le dessus de ce meuble.
- Ne jamais permettre à des enfants de monter sur les tiroirs, portes ou tablettes, ni de s'y suspendre.
- Ne jamais ouvrir plus d'un tiroir à la fois. (OU)
- Ne pas altérer ni retirer le système de verrouillage du tiroir.

L'utilisation d'un dispositif antibasculement ne peut que diminuer, et non éliminer, le risque de basculement.

Cette étiquette est permanente. Ne pas tenter de l'enlever.

⚠ ADVERTENCIA

El vuelco del mueble puede causar lesiones por aplastamiento e incluso la muerte. Para evitar que el mueble se vuelque:



- Instale los dispositivos antivuelco proporcionados.
- Guarde los artículos más pesados en los cajones inferiores.
- Evite colocar un televisor o un objeto pesado encima del mueble, salvo si éste último ha sido diseñado específicamente para dicho fin.
- No permita que los niños suban sobre los cajones, las puertas o los estantes ni que se cuelguen de dichas piezas.
- No abra más de un cajón a la vez. (O)
- No altere ni quite el sistema de cerradura del cajón.

El uso de un dispositivo antivuelco sólo disminuye el riesgo de vuelco, no lo elimina.

Esta etiqueta es permanente. No trate de quitarla.

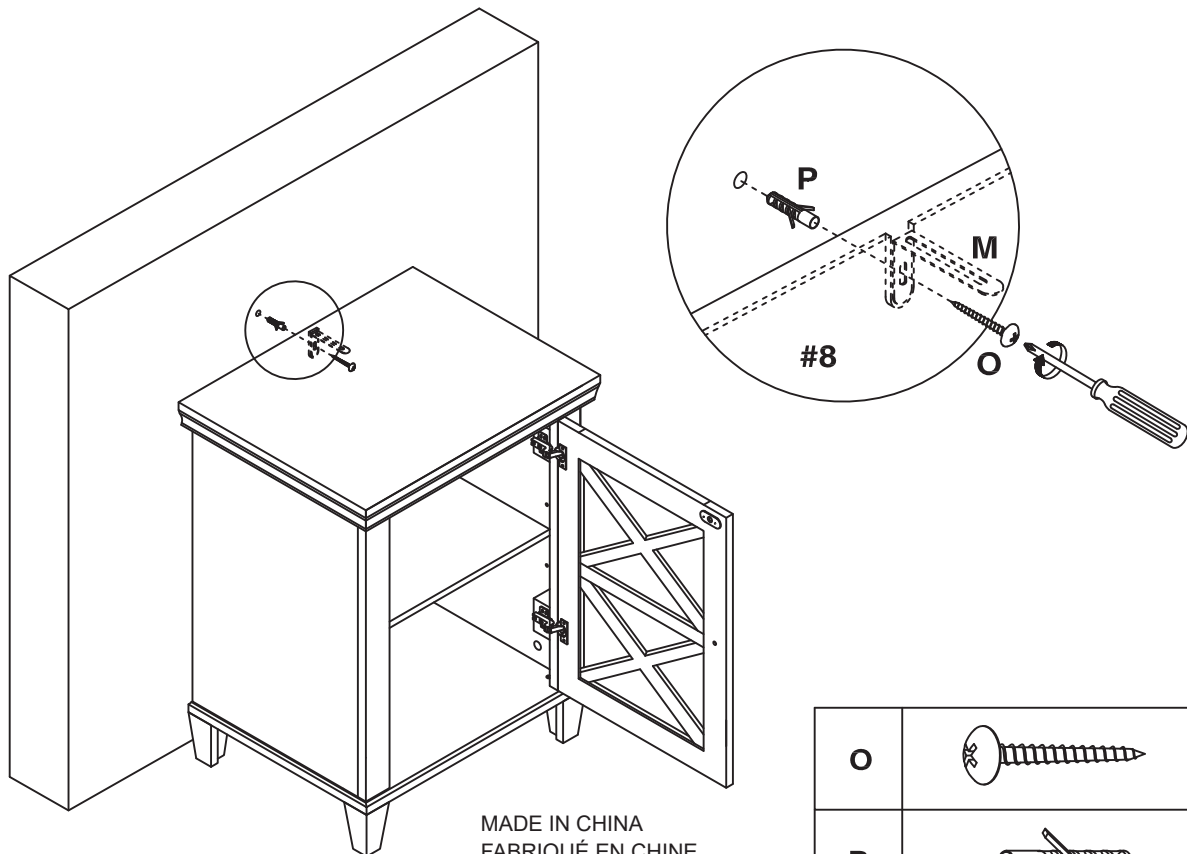
11.

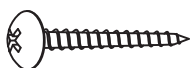

O		01
P		01