

WALKER EDISON
TM

Nightstand

SKU# WECHA012D4

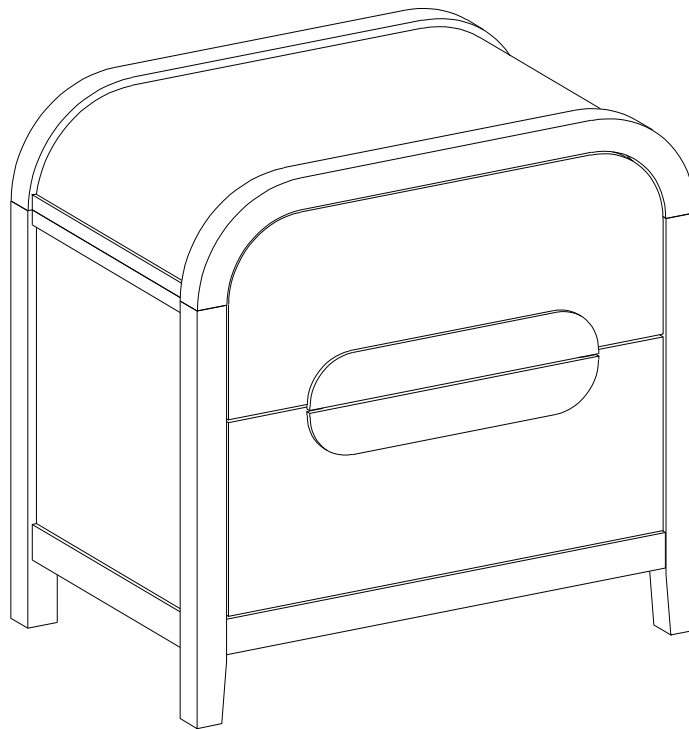

For Residential Use Only

Please visit our website for the most current instructions, assembly tips, report damage, or request parts. www.walkeredison.com



Time to get started

Set up a clean and soft workplace to get started and avoid damage during the assembly. It also helps to double-check that you've got all the pieces and parts before diving in to assembly.

Estimated time for assembly

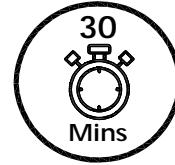

People recommended for assembly

Make it a team effort! Grab a friend for quicker, easier assembly.

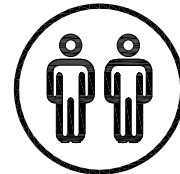

2 People Build

Tools Needed

Grab a Phillips head screwdriver to conquer this assembly

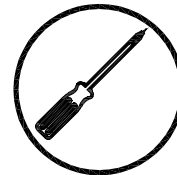

Use power tools with caution

You can cause cracking or damage to the material and easily strip the hardware. If you choose to use a power tool, your product will no longer be covered under Walker Edison's warranty.

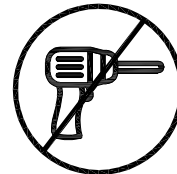

Glue is provided to secure wood dowels in place

When inserting dowels, locate the appropriate hole, place a small amount of glue in the hole, and then insert the dowel. Wipe away excess glue immediately.



Scan to get assembly tips and help!



Parts List





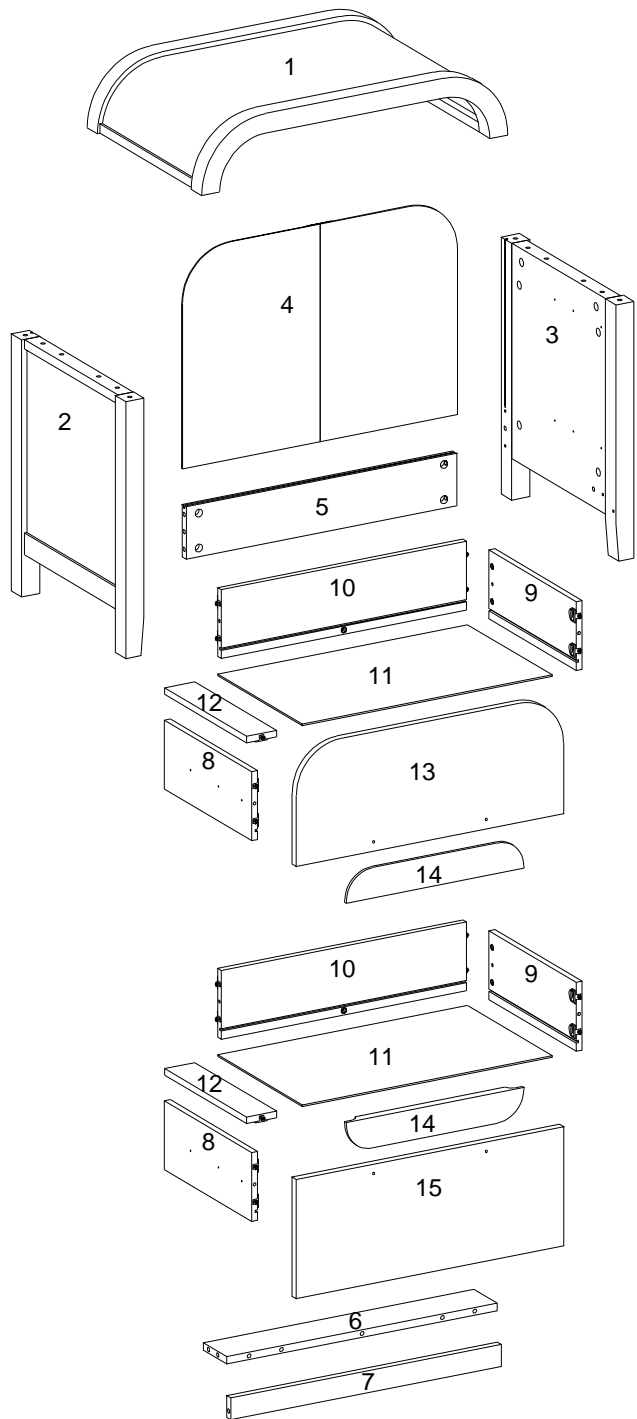

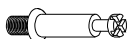

Part Number	Description	Quantity
-------------	-------------	----------

1	Top Arched Panel	1
2	Left Side Frame	1
3	Right Side Frame	1
4	Upper Back Panel	1
5	Lower Back Panel	1
6	Bottom Rail	1
7	Front Apron	1
8	Drawer Left Side Panel	2
9	Drawer Right Side Panel	2
10	Drawer Back Panel	2
11	Drawer Bottom Panel	2
12	Base Cross Bar	2
13	Upper Drawer Front Panel	1
14	Handle	2
15	Lower Drawer Front Panel	1



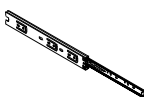
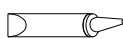

Hardware List

Part	Size	Name	Quantity
A	 8x30mm	Wooden dowel	14
B	 6x35mm	Cam bolt	15
C	 15x11mm	Cam lock	15
D	 30mm	Sticker	23
E		Plastic wedge	8
F	 3x17mm	Screw	8
G	 4x21mm	Handle Bolt	4
H	 6x30mm	Wooden dowel	8
J	 3.5x12mm	Screw	24
K		Drawer Glide <small>* Note: This piece comes preassembled for shipping purposes and must be disassembled to complete the desk assembly.</small>	2 sets
L		Glue tube	1

*The hardware quantities listed above are required for proper assembly.
Extra hardware pieces may be included.*

Step 1

Let's get started! Using a Phillips head screwdriver, screw cam bolts (B) into the Top Arched Panel (1).

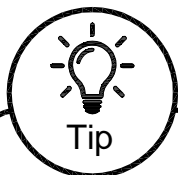
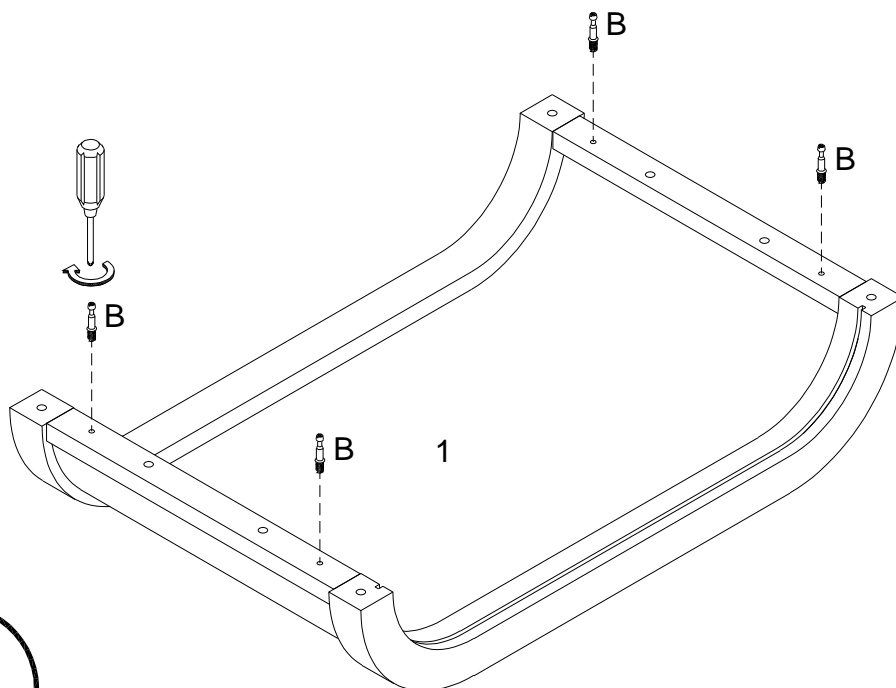

Tip

To keep your product looking its best and scratch-free, try assembling it on a soft surface like carpet or a blanket. This helps prevent any accidental scratches and keeps your furniture in top shape!

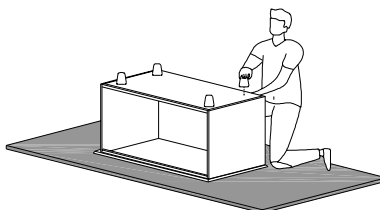

Step 2

Press the plastic lever to remove the drawer member from the cabinet member on each drawer glide (K).

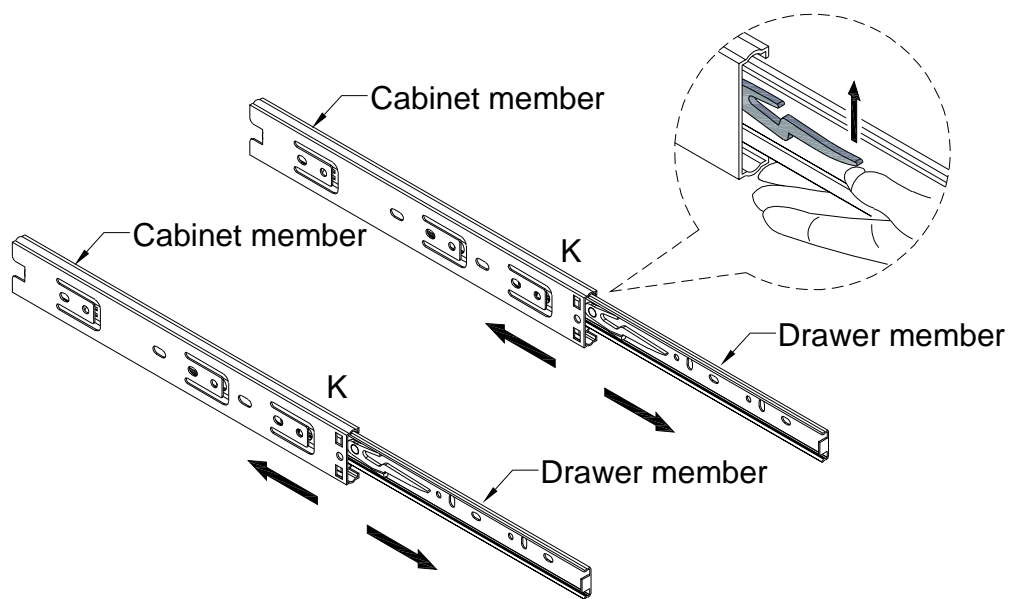

Step 3

Secure the cabinet-side portion of each drawer glide (K) to the Left Side Frame (2) and Right Side Frame (3) using screws (J). Next, install cam bolts (B) and wooden dowels (A) into both frame pieces.

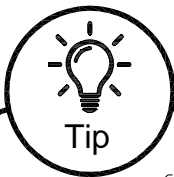
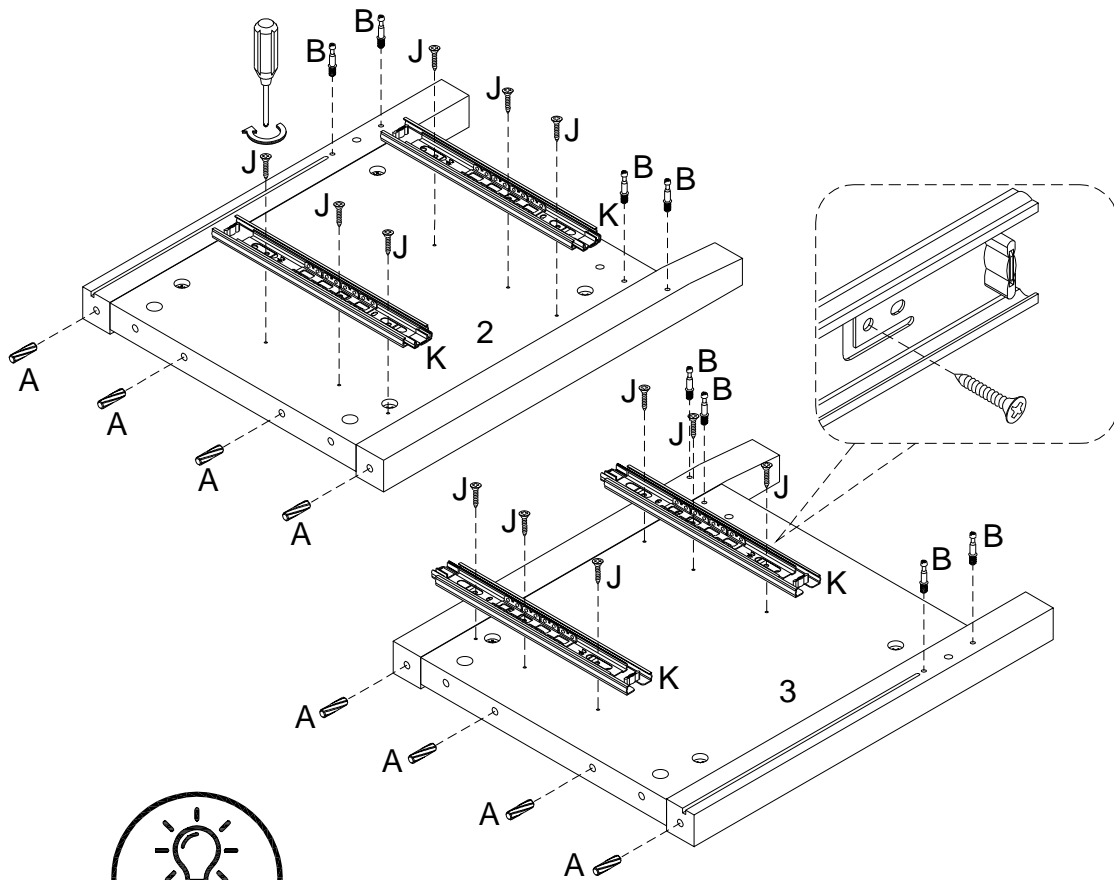

Tip

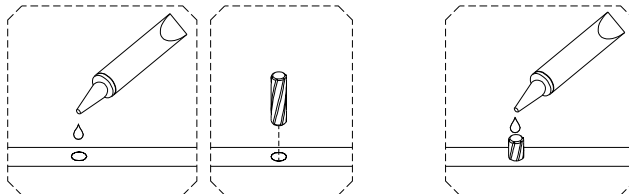

1: The provided glue is to secure wood dowels in place. When first inserting dowels, locate the appropriate hole for the dowel, place a small amount of glue in the hole and insert the dowel. Wipe away excess glue immediately.

2: In future assembly steps when dowels are necessary to attach assembly parts together, place a small amount of glue on the end of the dowel before attaching parts together. Wipe away excess glue immediately.

Step 4

Insert wooden dowels (A) into the Lower Back Panel (5) and the Bottom Rail (6). Then, screw cam bolts (B) into the Front Apron (7).

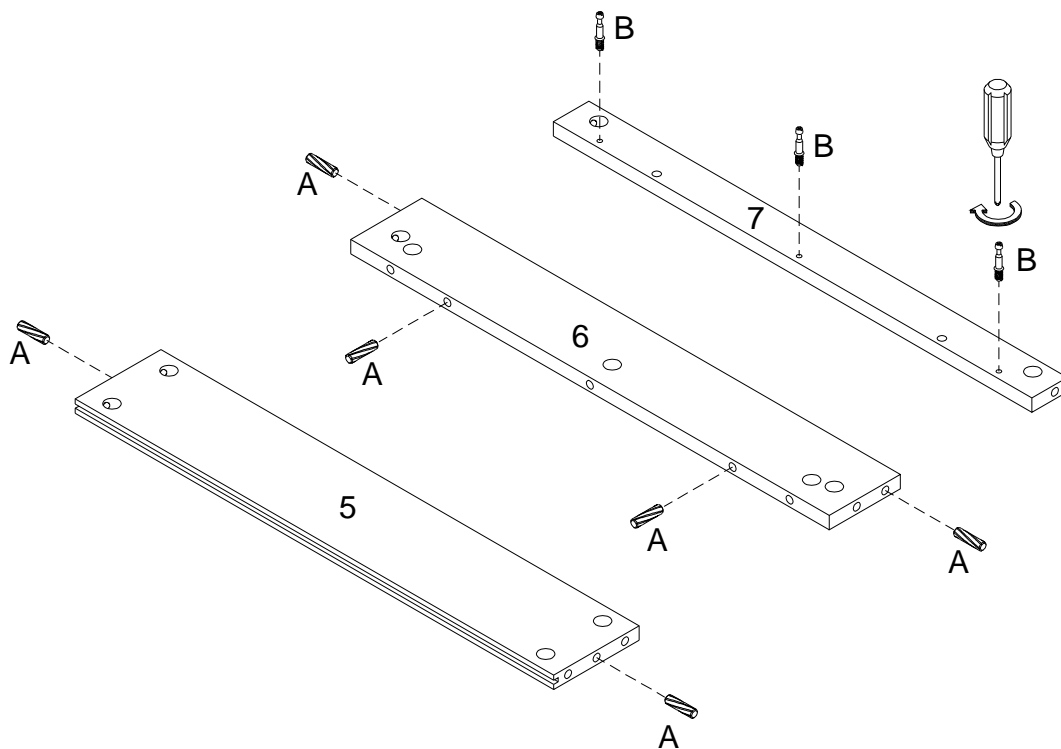

Step 5

Connect the Front Apron (7) to the Bottom Rail (6). Insert cam locks (C) and tighten with a screwdriver.

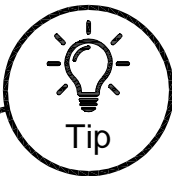
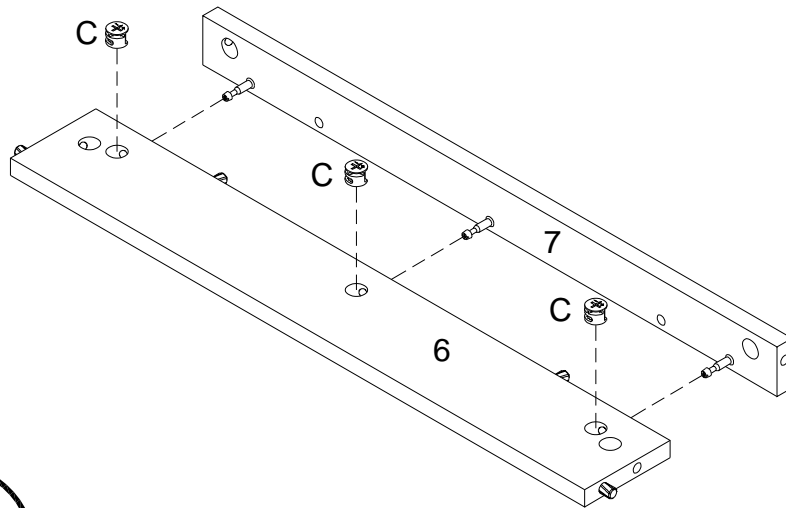

Tip

Cam Locks

Cam Locks help securely join two pieces together. Follow these easy steps.

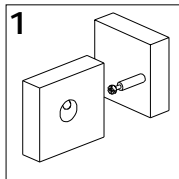

1: Insert Cam Bolt into bolt holes on the flat side. Don't over tighten!

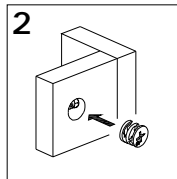

2: Fit the proper holes on the edge of the other part over the Cam Bolts. You should be able to see the cam bolts through the larger hole on the side.

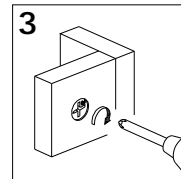

3: On the back of the Cam Lock will be a "C" shape. Insert the Cam Lock so the opening of the "C" fits over the Cam Bolt. Tighten with the screwdriver.

Step 6

Now, attach the Front Apron (7)/Bottom Rail (6) and the Lower Back Rail (5) to the Left Side Frame (2). Insert cam locks (C) and tighten with a screwdriver.

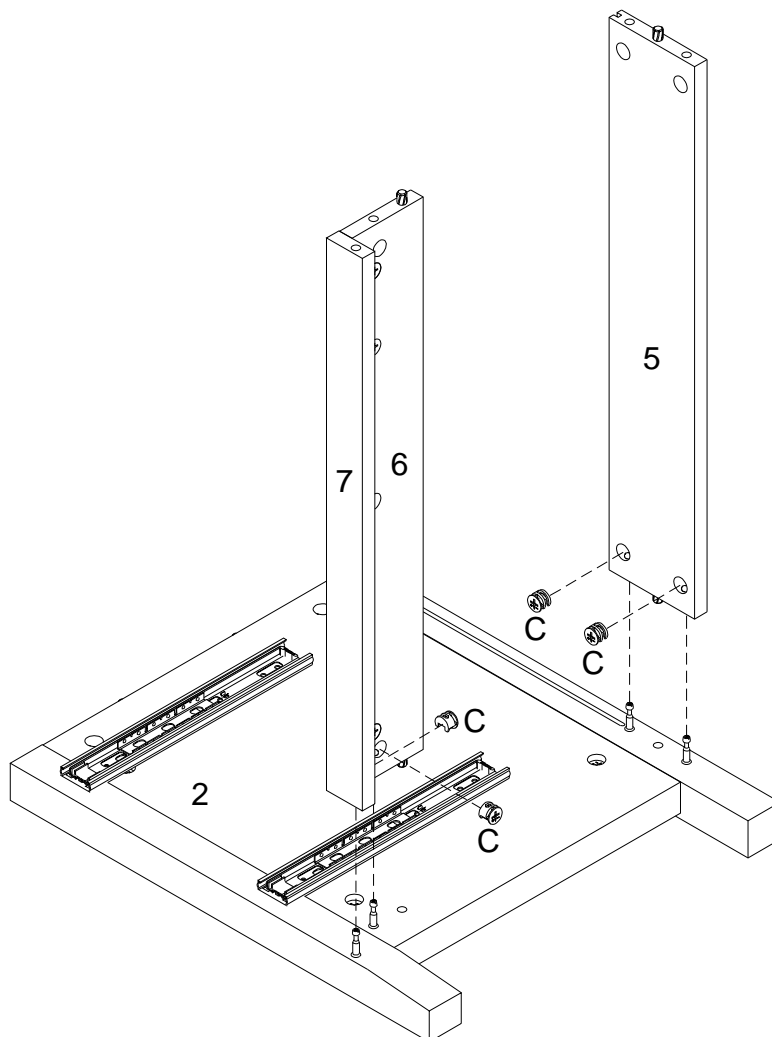

Step 7

Secure the Right Side Frame (3) to the other side of the Front Apron (7)/Bottom Rail (6) and the Lower Back Rail (5). Insert cam locks (C) and tighten with a screwdriver.

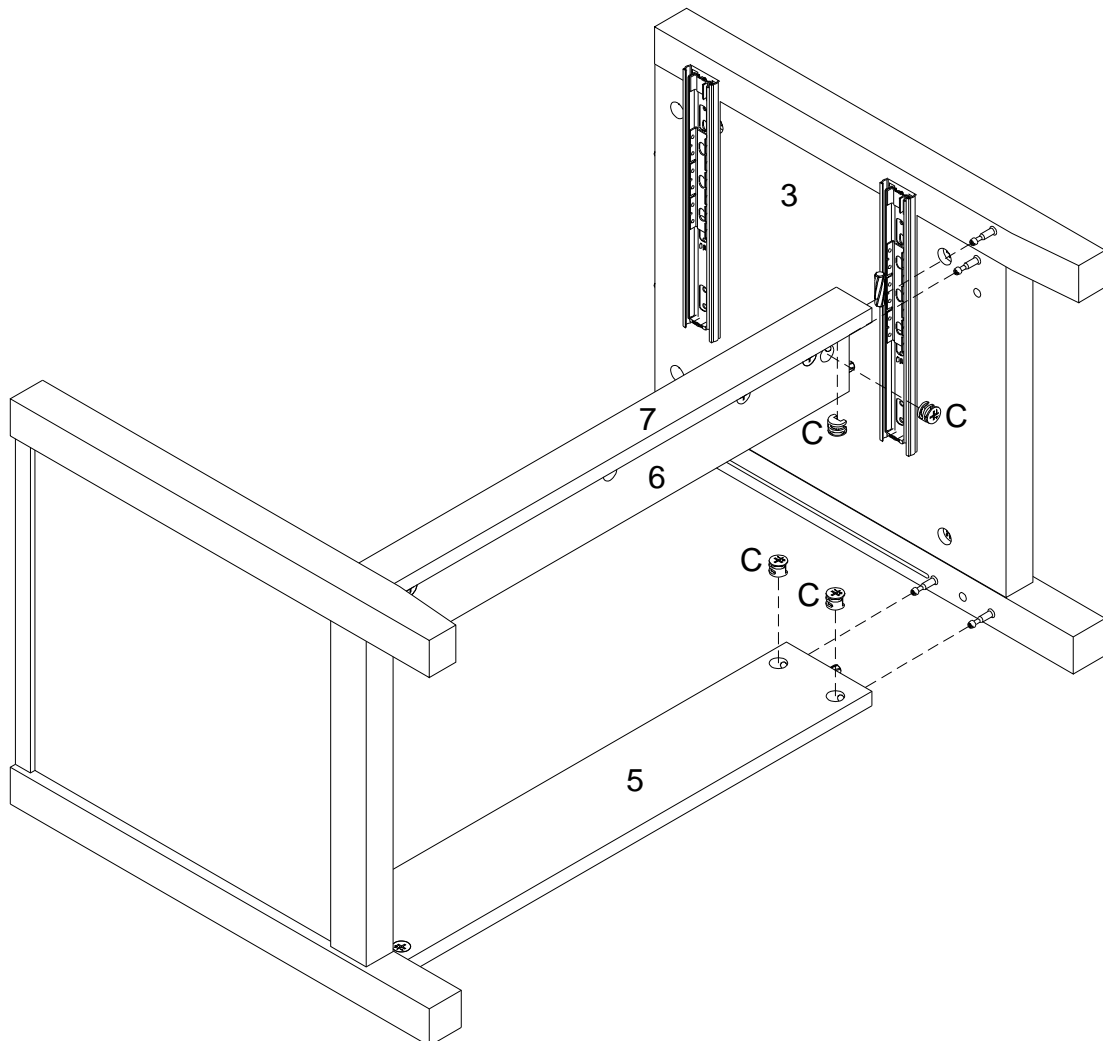

Step 8

Unfold the Upper Back Panel (4) and slide into place using the grooves as your guide.

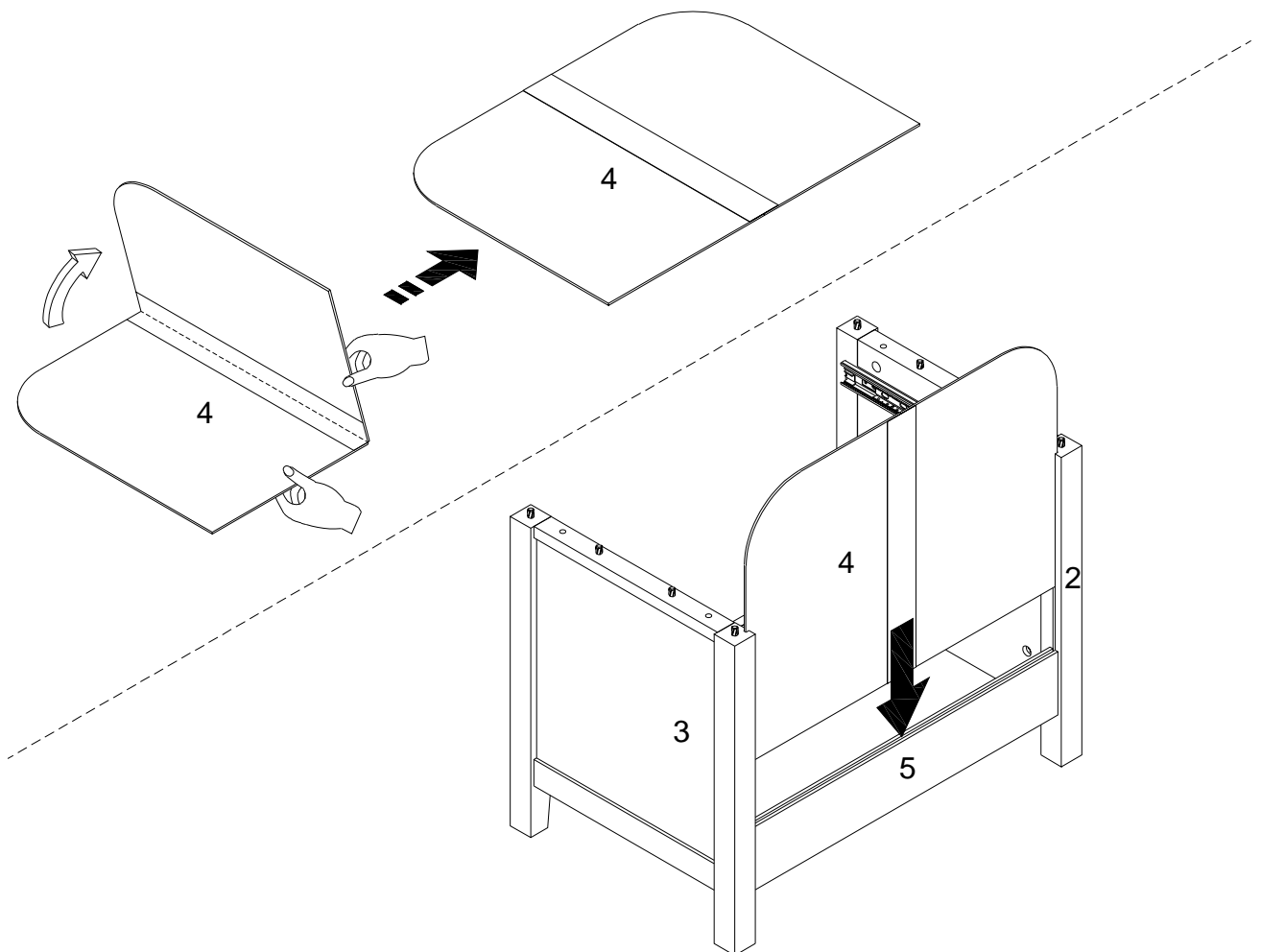

Step 9

Fit the Top Arched Panel (1) to the rest of the unit. Insert cam locks (C) and tighten with a screwdriver.

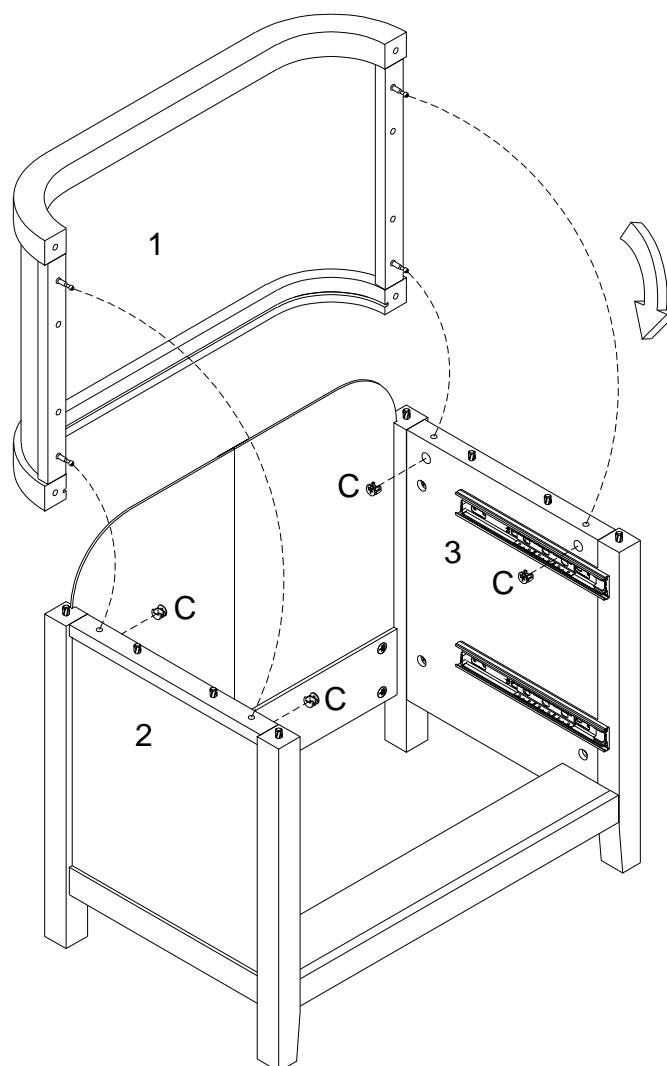

Step 10

Evenly space the plastic wedges (E) between the Upper Back Panel (4) and the frame. Secure with the (F) screws.

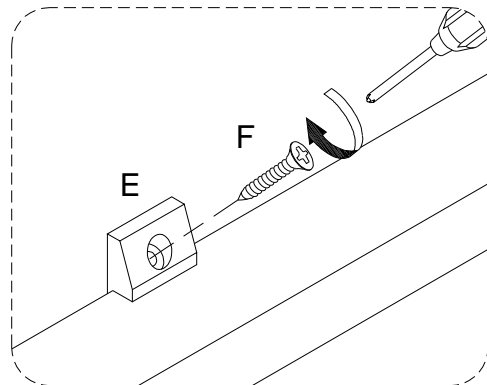
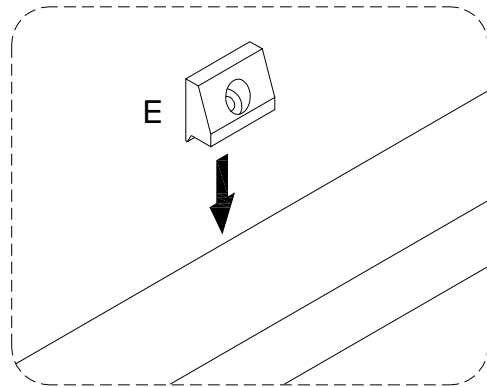
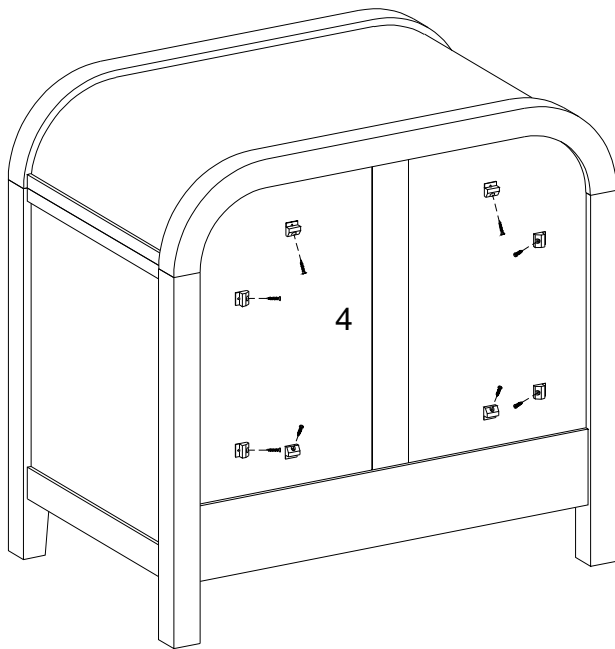

Step 11

Use the provided stickers (D) to ensure a clean finish.

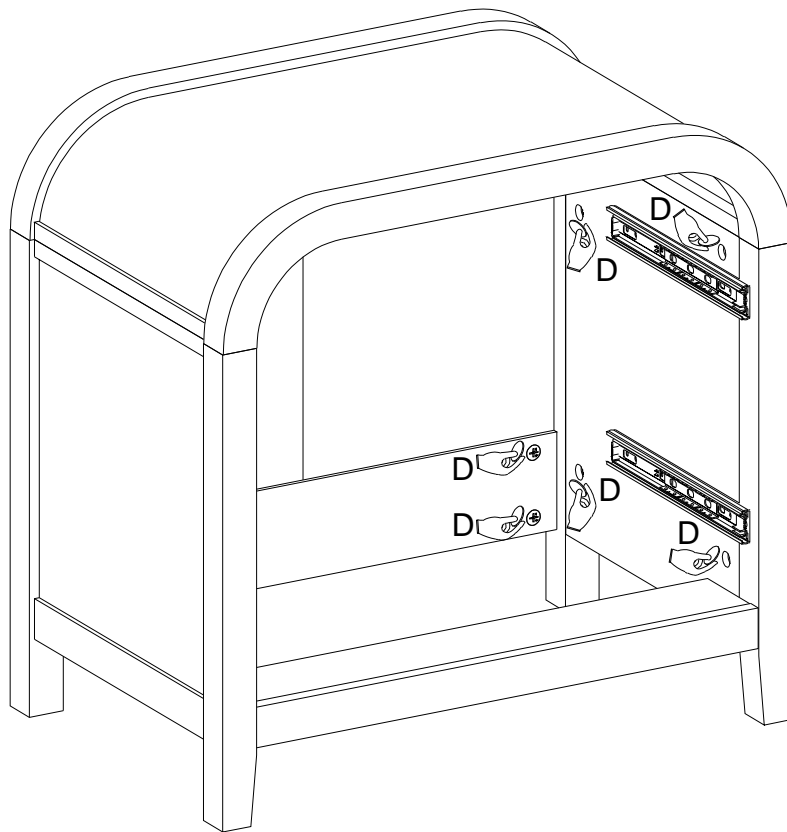

Step 12

Now, using the (G) screws, secure a Handle (14) to both the Upper Drawer Front Panel (13) and the Lower Drawer Front Panel (15).

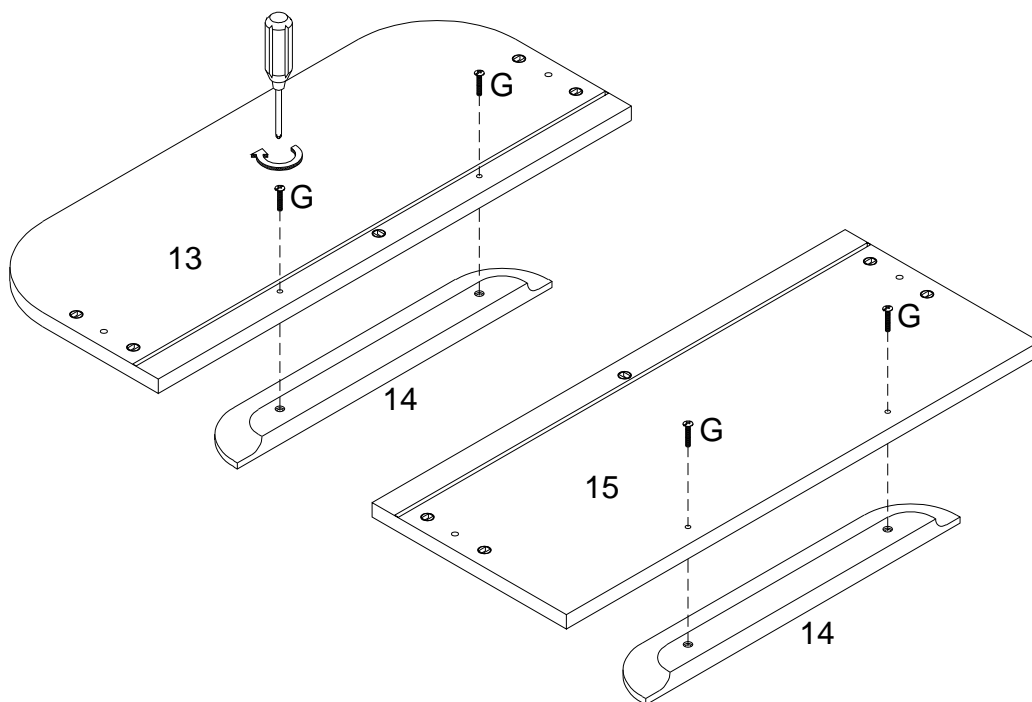

Step 13

Insert wooden dowels (H) into the Drawer Left Side Panel (8), Drawer Right Side Panel (9), and the Drawer Back Panel (10). Then, using the (J) screws, secure the drawer side of the drawer glides (K) to the Drawer Left Side Panel (8) and the Drawer Right Side Panel (9). Repeat this step once more for the second drawer.

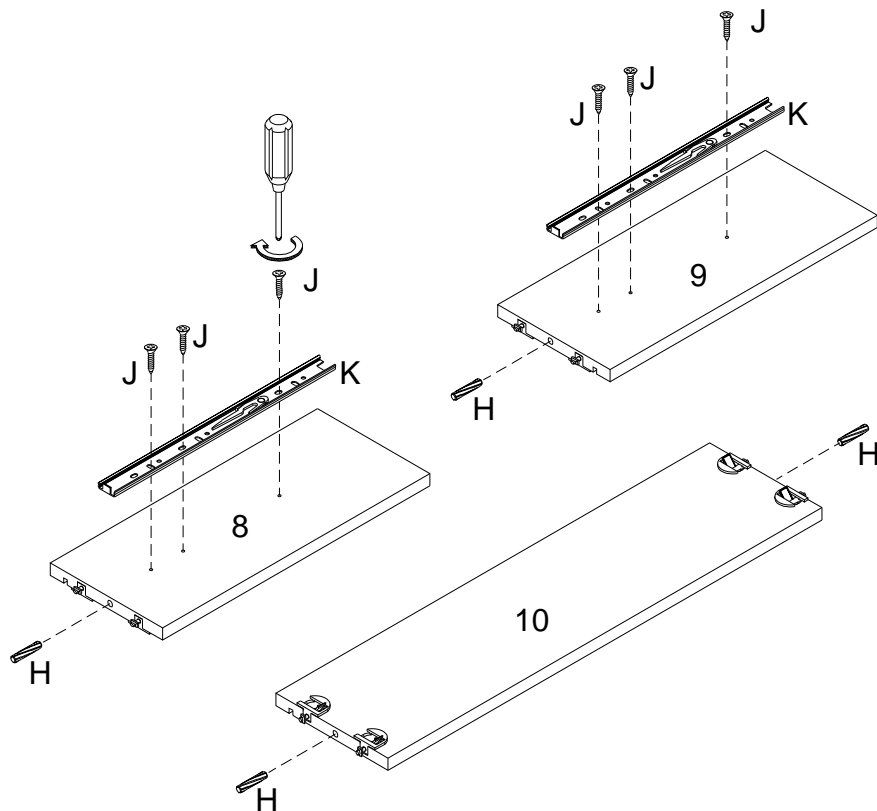

x 2

Step 14

Using the quick assembly mechanism, connect the Drawer Right Side Panel (9) and the Drawer Left Side Panel (8) to the Drawer Back Panel (10). Repeat this once more for the second drawer.

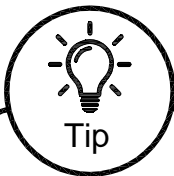
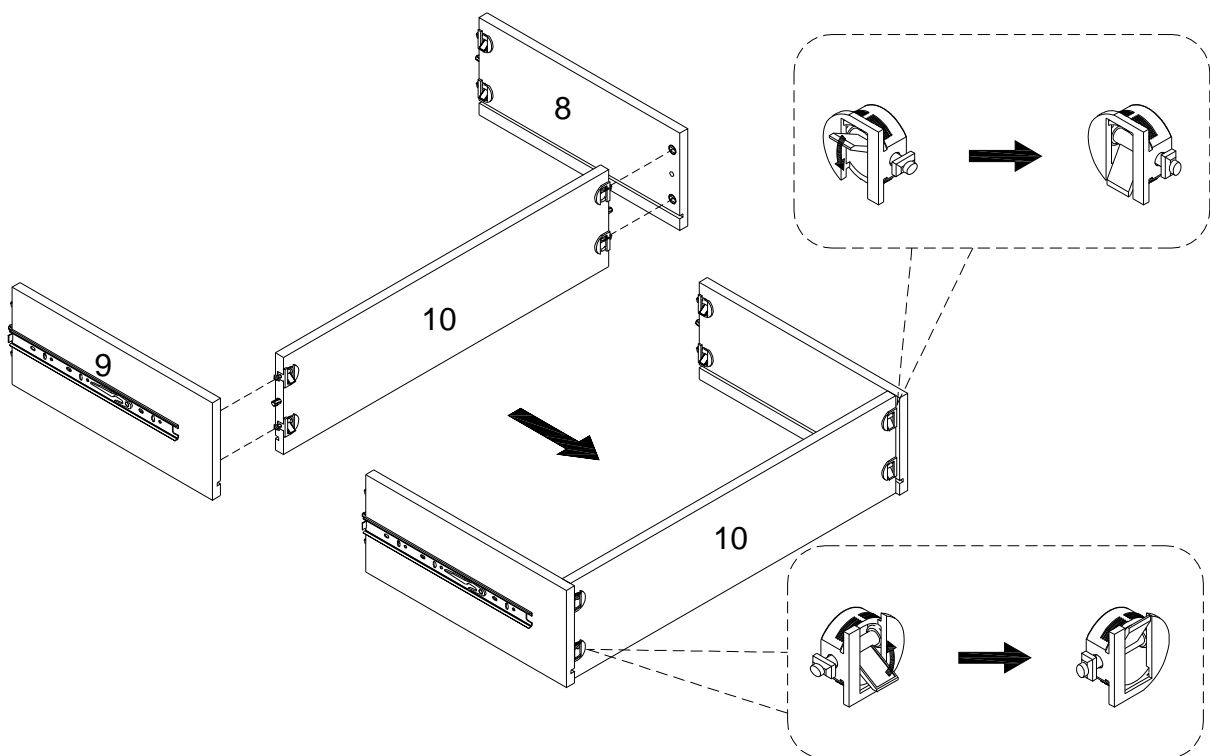

x 2

Quick Assembly Drawers

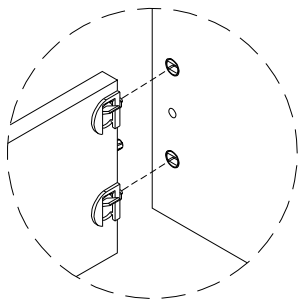

1. Make sure the quick assembly drawer pin is aligned with the corresponding hole.

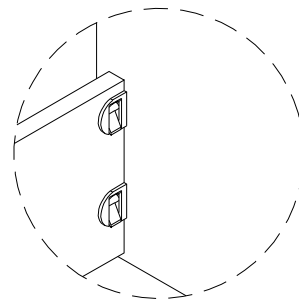

2. Once the pin is inserted correctly, flip the metal lever in the opposite direction to ensure the panels are firmly locked together.

Step 15

Secure a Base Cross Bar (12) to both Drawer Back Panels (10).

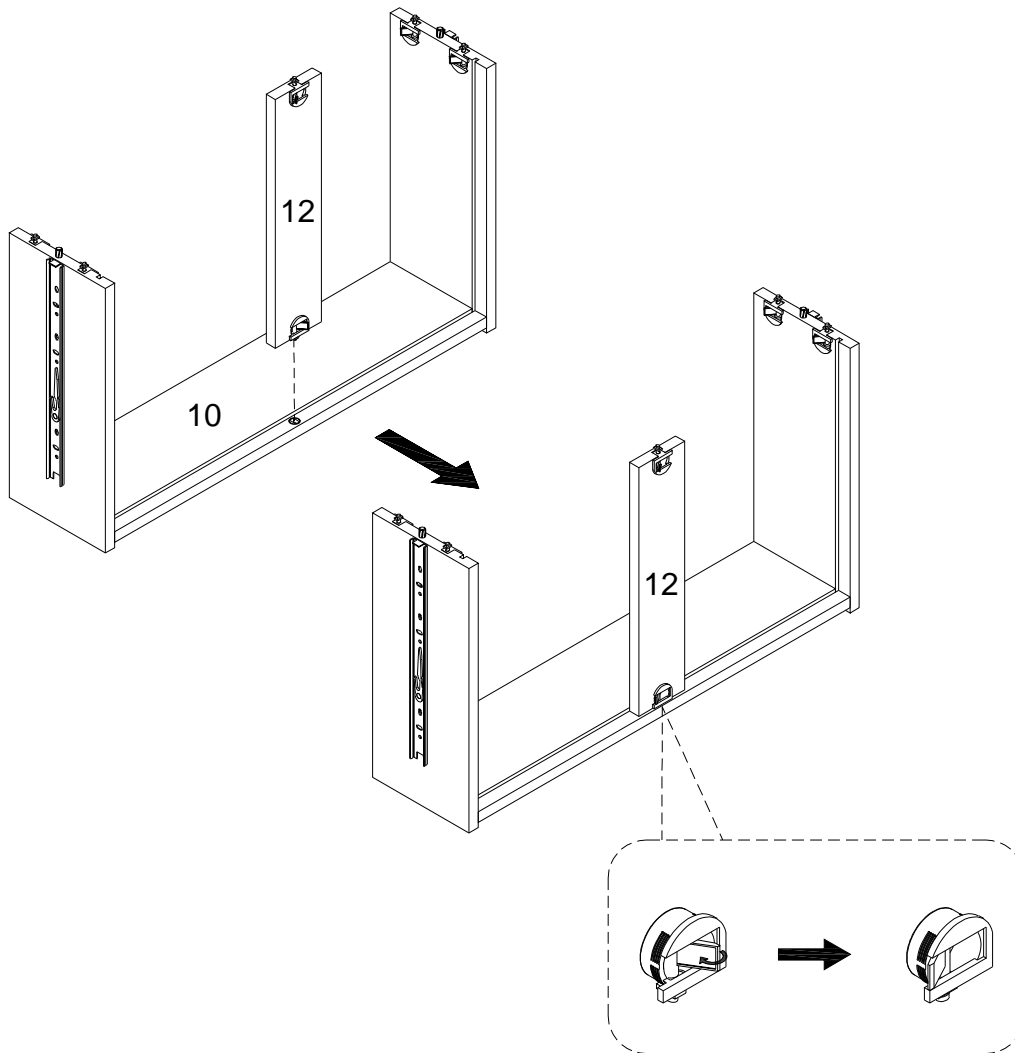

x 2

Step 16

Insert the Drawer Bottom Panel (11). Repeat this once more for the second drawer.

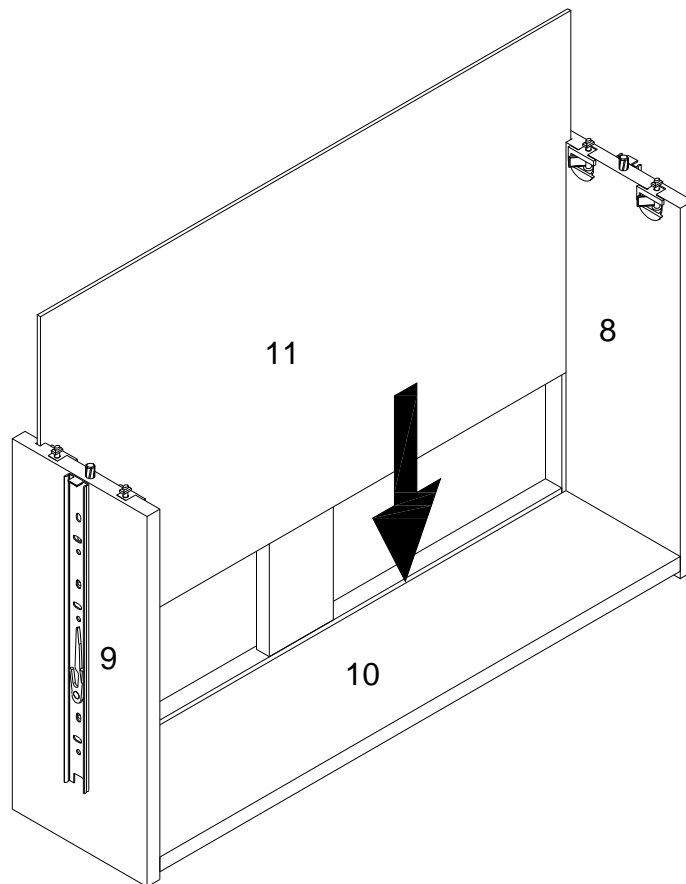

x 2

Step 17

Attach the Upper Drawer Front Panel (13) and secure with the quick assembly mechanism.

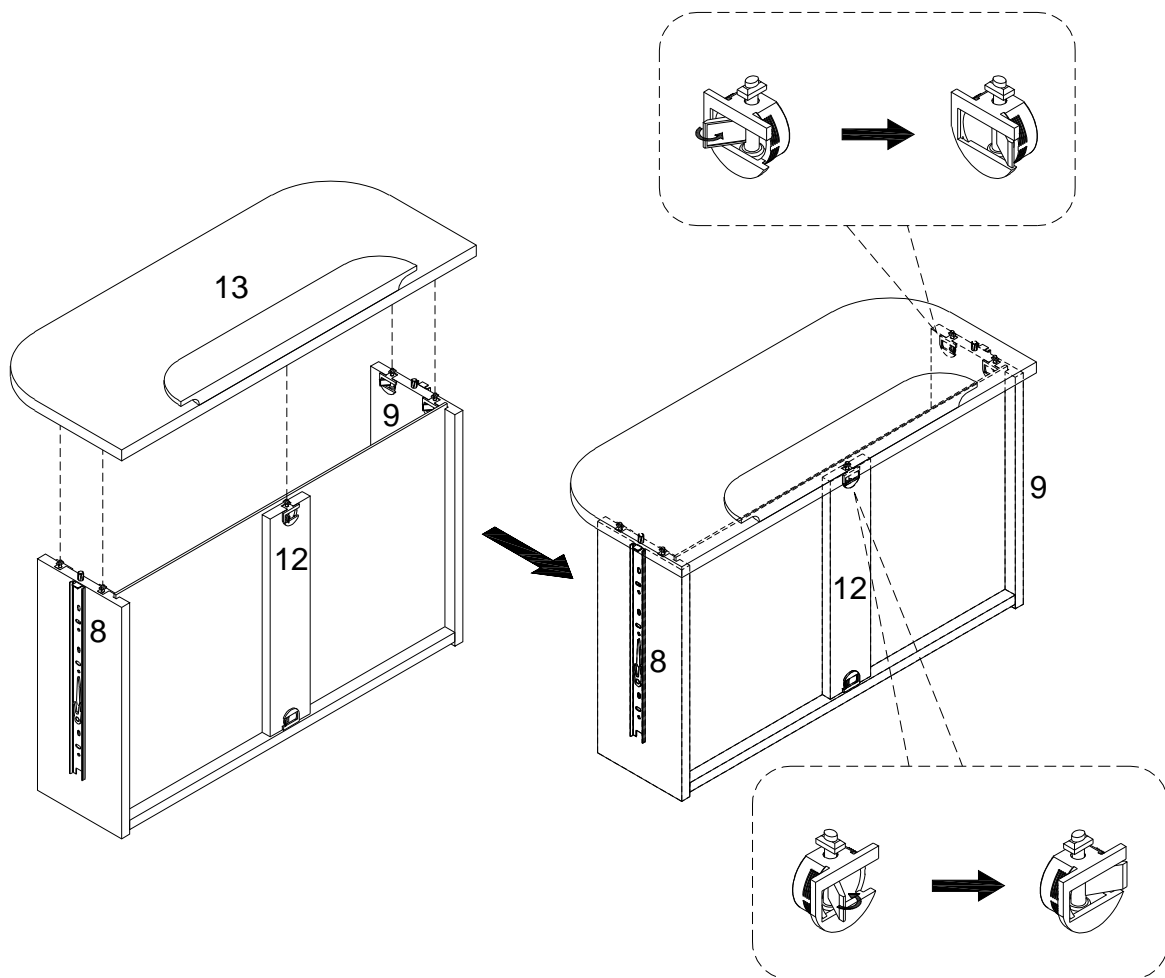

Step 18

Attach the Lower Drawer Front Panel (15) and secure with the quick assembly mechanism.

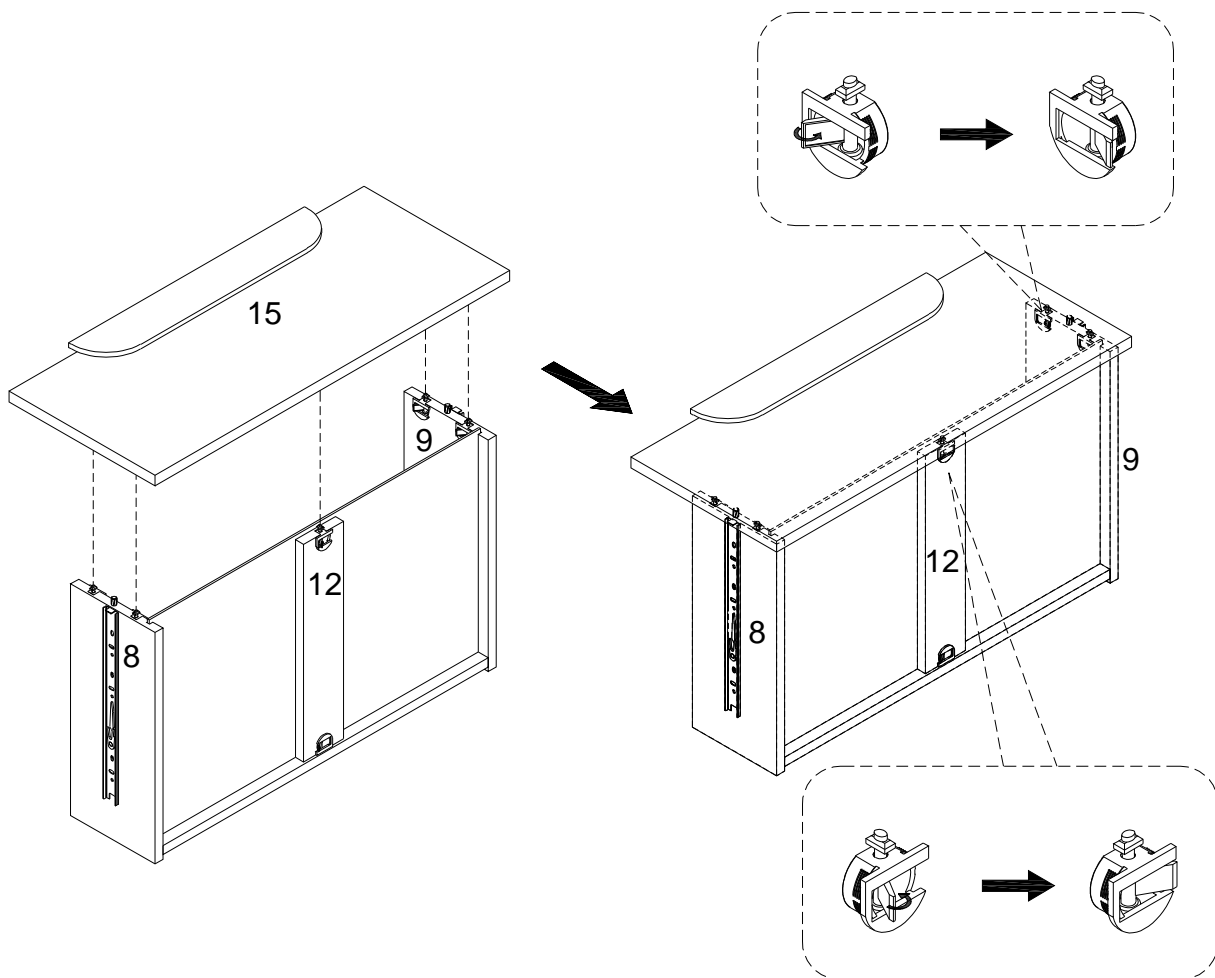

Step 19

Firmly push the drawers all the way into place making sure the drawer member lines up with the inside guides of the cabinet member. Some resistance is normal.

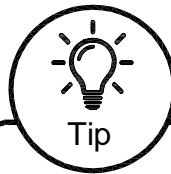
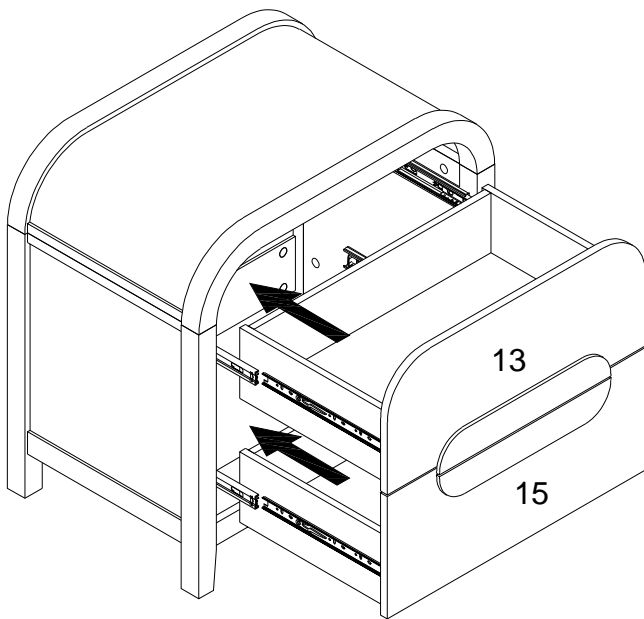

Tip

Reinserting your Cabinet Glides together

Line up the Drawer Member so it is inside the guides of the Cabinet Member. Once the connection is made, push the drawer into place entirely. It may not be a smooth glide on your first try, but will improve after it's fully inserted.

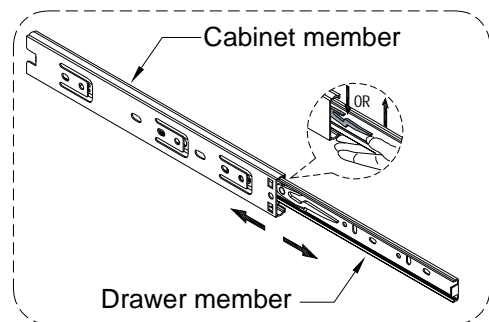

Final Assembly

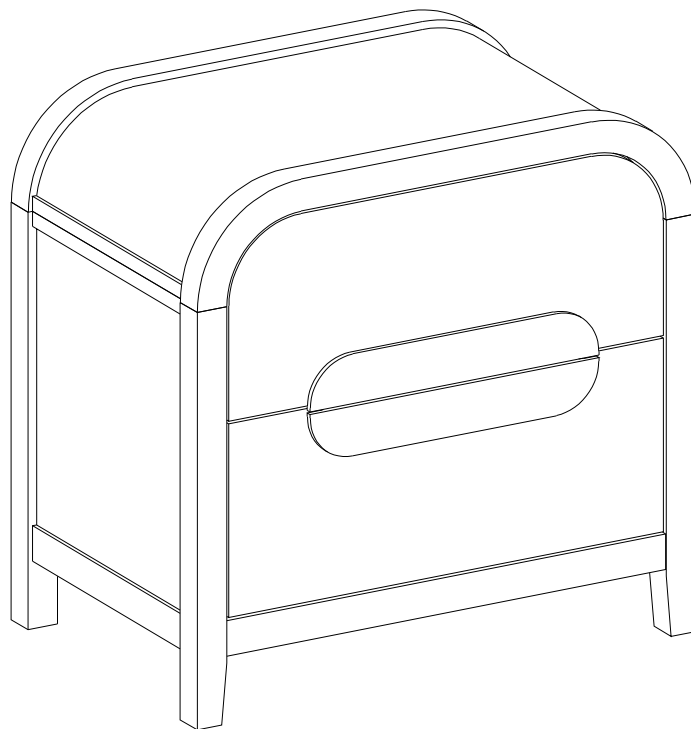

Congratulations on your new piece of furniture!

We would love to hear about it and see it.
Please leave us a review or post a picture with
[#mywalkerredisonhome](#)

Assembling furniture can be tricky sometimes.

Our customer service team, located in Utah, is here for product information, help assembling a product, or for any other customer support issue

Call us at **801-433-3008**

Email us at service@walkeredison.com

Visit our Customer Service website at
walkeredison.com/pages/customer-service

We are available to help Monday -Thursday 8am-5pm, Friday
8am-3pm MST

For details on Assembly Videos, Assembly Instructions,
Replacement Parts, and Customer service,
SCAN HERE

