

Limited 1-Year Warranty

- 1) The warranty is a consumer warranty and applies only to products manufactured by Corporate Images under this name. Products must have been purchased from an authorized our Distributor or Dealer, recognized by Corporate Images.
- 2) The warranty period is from the verified purchased date of the product. The warranty is expressly limited to the replacement of components having manufacturer defects only and on current available models. No assembly labor is included. Possible replacement of components or parts does not extend this limited warranty or begin a new warranty period.
- 3) Corporate Images products are warranted to the original purchaser and are not transferable. The warranty is limited to defects in manufacturing, materials, and workmanship. This warranty does not apply to normal wear and tear. If the product has been subject to abuse, misuse, improper care or use of the product, the warranty is void. **CORPORATE IMAGES WARRANTY DOES NOT COVER ADJUSTABLE SHELVES.**
- 4) The consumer has purchased this as a Ready-To-Assemble product, which involves "Do-it-yourself", assembly, including: handling, transporting, assembling and erecting the product. Corporate Images shall not be liable for incidental or consequential damages, which results through the use of Corporate Images products.
- 5) This warranty includes any statutory legislation in the jurisdiction where the product is purchased and does not exclude or limit your legal right.
- 6) Warranty service is available by contacting Corporate Images. Warranty period to be verified by date of manufacturing and original/receipt of sale.

Television Bench
Banc de Télé
Banco de televisión

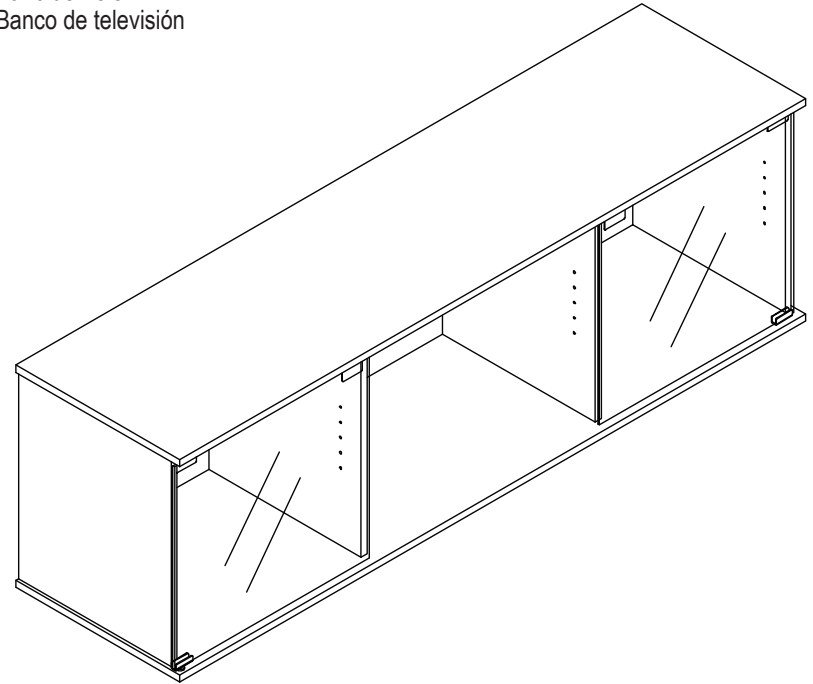

STOP! | ARRETE! | ALTO!

The PO number on this instruction manual is required for product registration and all warranty claims. Absolutely no exceptions can be made: no warranty claim will be accepted without a valid run number.

Ensure you have access to the PO number for the duration of your ownership.

Le numéro de PO sur les manuels d'entretien est requis pour l'enregistrement et pour toutes les garanties du produit. N'absolument pas d'exceptions: Les garanties du produit ne vont pas être accepter sans un numéro de fabrication valable.

Assurer que vous avez access au numéro de PO pour la duration de votre possession.

El PO número en este manual de instrucción es requerido para la matrícula de producto y todas las reclamos de garantía. Absolutamente no excepciones pueden ser hechas: ningún reclamo de garantía será aceptado sin un válido corre el número.

Asegure que tenga acceso al PO número durante su propiedad.

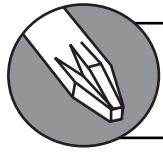

**TOOLS REQUIRED
OUTILS REQUIS
HERRAMIENTAS REQUERIDAS**

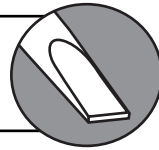

If you are to use any form of electrical drill, please have the torque at a **LOW** setting.
Si vous utilisez une perceuse électrique pour visser, réglez-la à une basse vitesse.
En caso de usar una broca eléctrica, asegúrese de ponerla en una posición lenta.



Read this assembly manual carefully, and verify that you have all the parts listed before you begin. Keep your assembly manual for future reference.

Lisez ce manuel de montage soigneusement. Soyez sûr que vous avez toutes les pièces d'équipement avant de commencer. Gardez ce manuel de montage pour futur référence.

Lea cuidadosamente todo el manual de ensamblaje. Asegúrese de tener todas las partes que vienen enlistadas en el manual de montaje. Guarde este manual para referencias futuras.



Do not place heated objects on top of any surface. Always use a coaster or mat. Never leave liquids on the surface. Clean immediately with a mild cleaner and a damp cloth. Do not use wax or polish.

Jamais mettre des objets chauds ou des liquides sur les surfaces peintes. Utilisez un dessous de verre. Lavez avec un détergent doux et un tissu humide. N'utilisez pas des cires ou vernis.

No ponga objetos calientes, ni líquidos, arriba de cualquier superficie, siempre use algún protector. Limpiece ligeramente con tela húmeda. Nunca use cera o lustre para limpiar la superficie.



Protect finishes by placing furniture pieces on a soft carpeted surface during assembly.

Protégez la finition en plaçant les pièces du meuble sur un tapis doux pendant l'assemblage.

Proteja fines colocando pedazos de muebles en un suave alfombraron superficie durante la asamblea.

11

Tilt the glass door into position sliding it inside the bottom hinge then tighten the screws on the lower hinge.

Inclinez la porte de verre en place dans la charnière inférieure et serrez les visses en plastique sur la charnière inférieure.

Incline la puerta de cristal en la posición que la resbala dentro de la bisagra inferior después apriete los tornillos plásticos en la bisagra más baja.

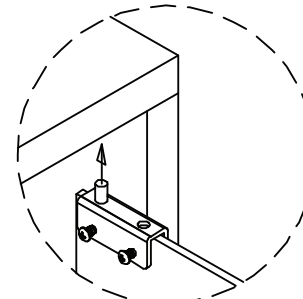

DETAIL A

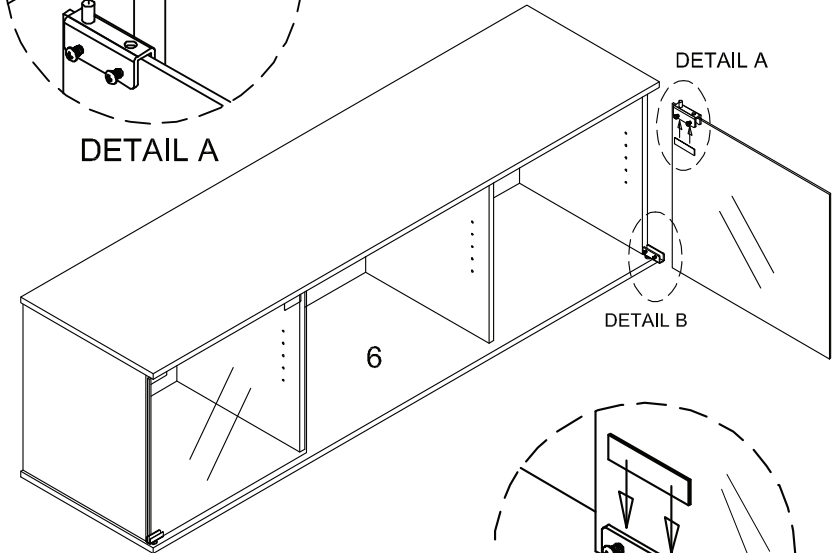

DETAIL A

DETAIL B

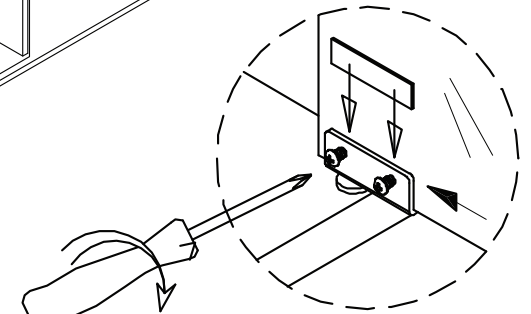

DETAIL B

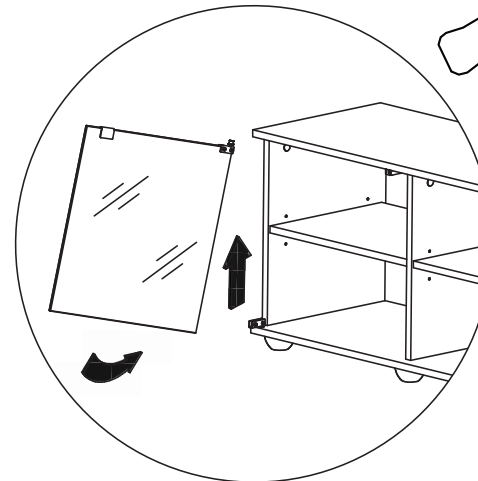

10

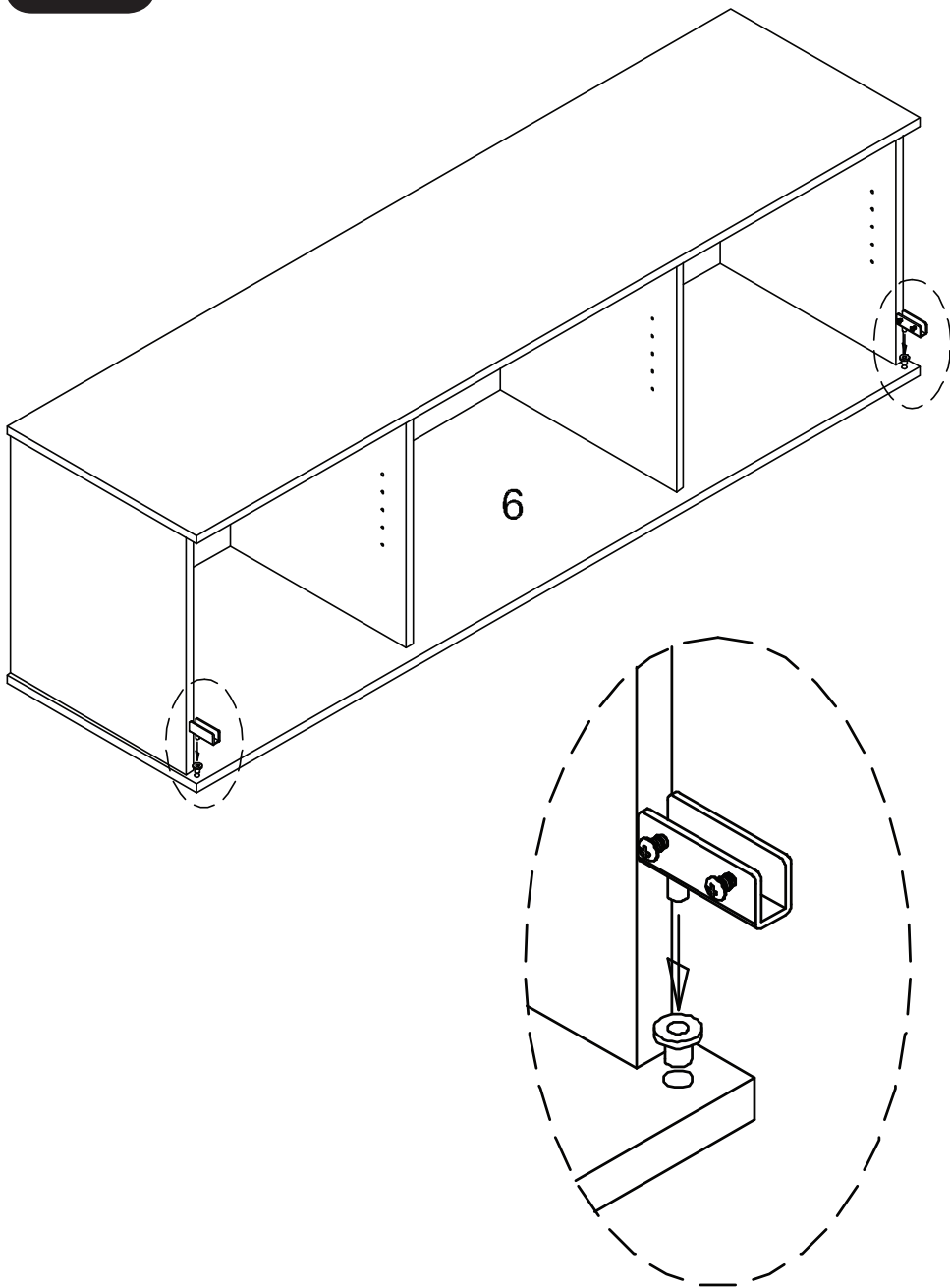

Hardware List

SCREW
M5.1 X 38
8 PCS

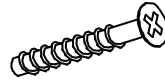

PAN HEAD
SCREW M3.5X16
8 PCS



WOOD DOWEL
M8X25
16 PCS

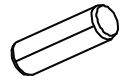

GLUE
1 PC



HOUSING
D15/12.5
8 PCS

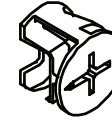

EURO BOLT
8 PCS

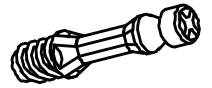

SOFA LEG
8 PCS

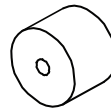

SCREW
#8 X 1/4"
8 PCS



SINGLE
MAGNET SET
2 SETS

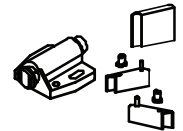

NAIL
22 PCS

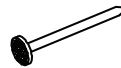

METAL
ADJUSTABLE
SHELF STUD
12 PCS



TEMPERED
GLASS
2 PCS

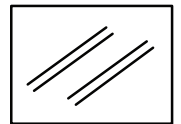

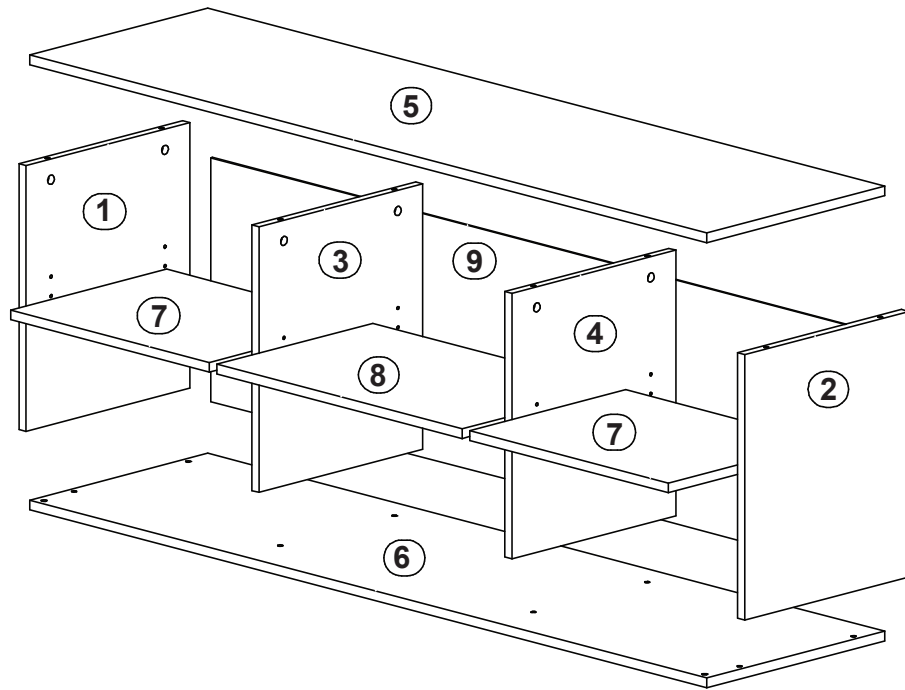

1 Outer Upright - Left
Montant Externe - Gauche
Externo correcto - Izquierdo

6 Base
Base
Base

2 Outer Upright - Right
Montant Externe - Droite
Externo correcto - Derecha

7 Outer Shelf
Étagère externe
Externo Estante

3 Inner Upright - Left
Montant du Milieu - Gauche
Montante correcto- Izquierdo

8 Inner Shelf
Tablette du Milieu
Montante Estante

4 Inner Upright - Right
Montant du Milieu - Droite
Montante correcto - Derecha

9 Backing
Endos
Apoyo

5 Top
Haut
Cima

9

SINGLE
MAGNET SET
2 SETS

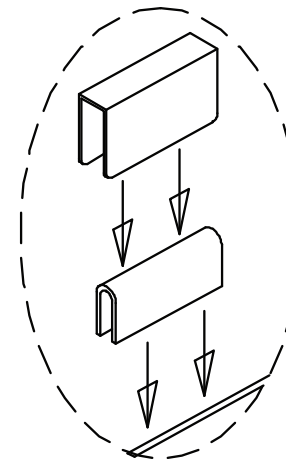
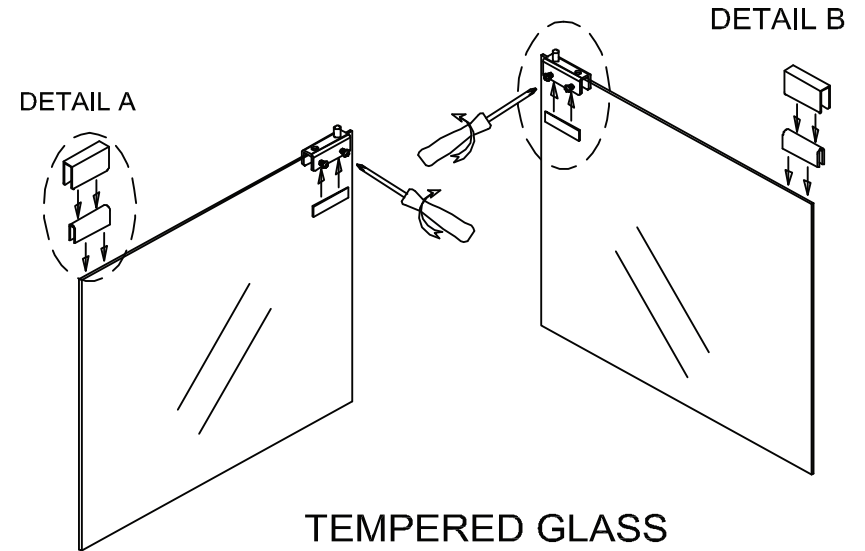
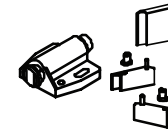

DETAIL A

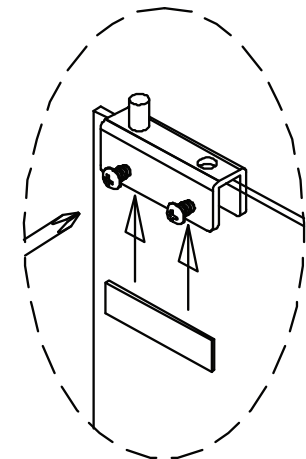

DETAIL B

8

METAL
ADJUSTABLE
SHELF STUD
12 PCS

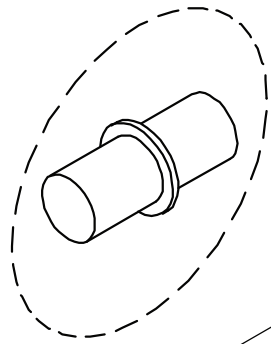

METAL ADJUSTABLE
SHELF STUD

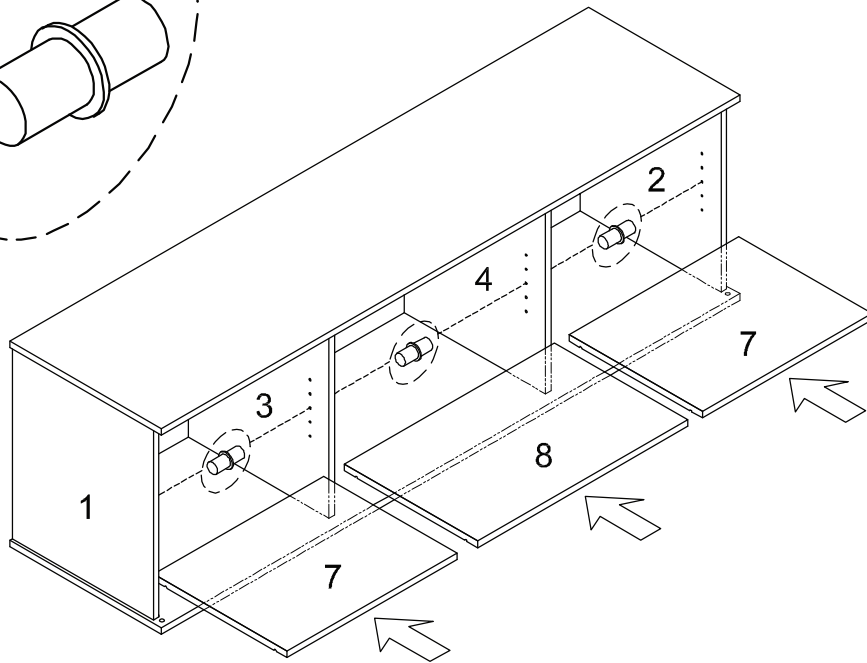

1

WOOD DOWEL
M8X25
16 PCS

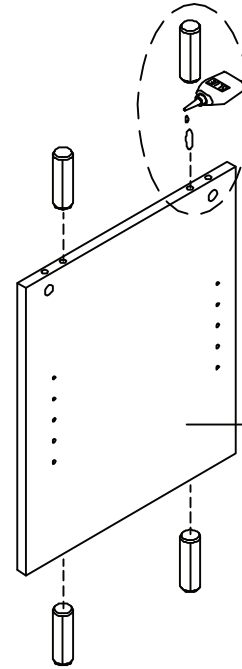

1,2,3 & 4

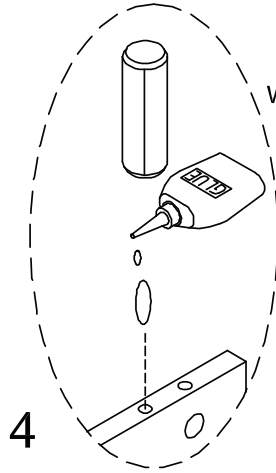

WOOD DOWEL M8X25

GLUE BOTTLE

2

PAN HEAD
SCREW M3.5X16
8 PCS

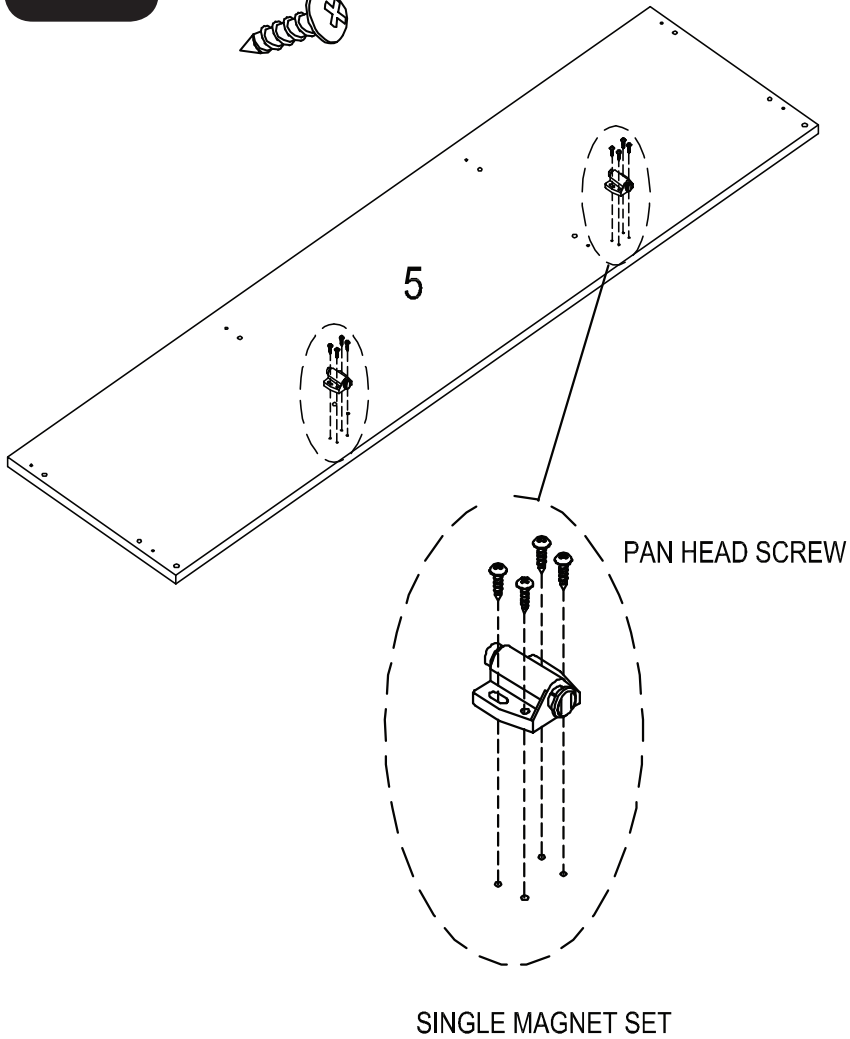

7

NAIL
22 PCS

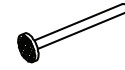

When nailing, make sure nails are centered to uprights preventing finish from splitting or damaging.

Assurez-vous de clouer les clous au centre de l'endos pour prévenir des dommages à la finition.

Al clavar, la marca clavos seguros son centrados para tomar partido prevenir vertical fin de partir o daños.

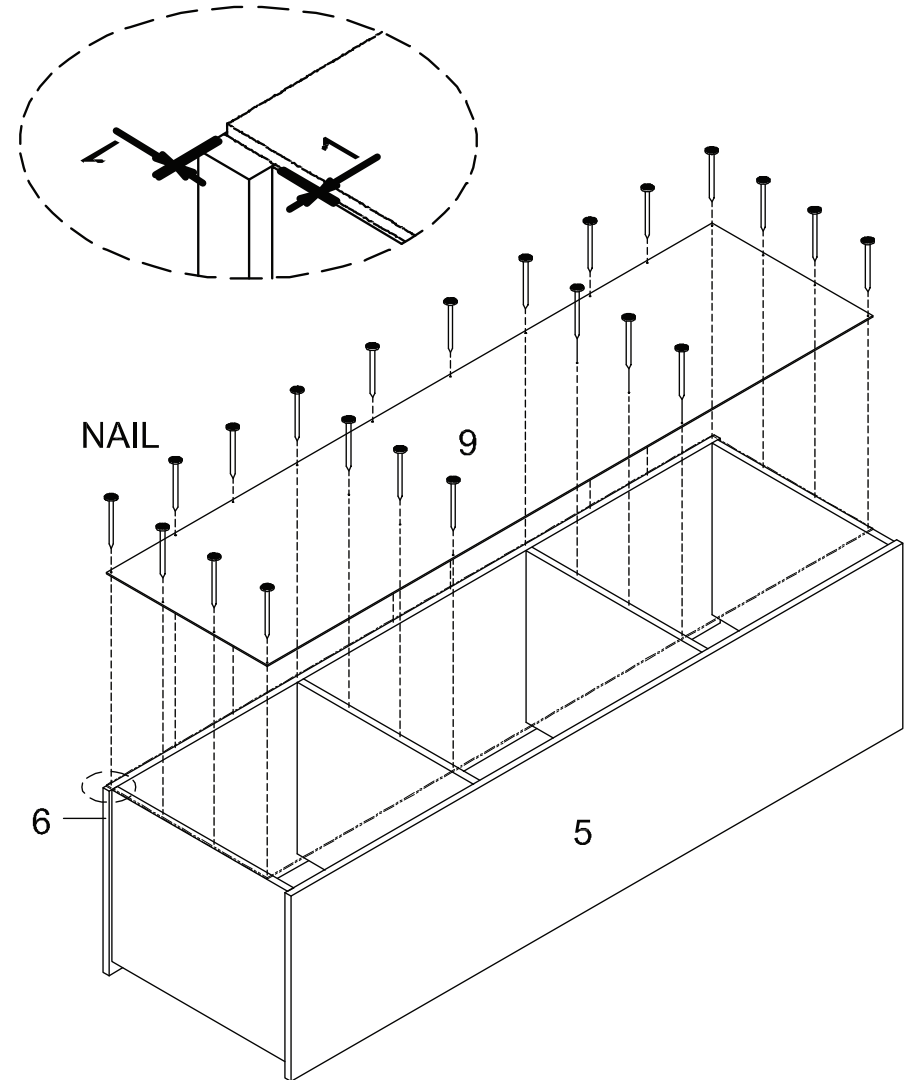

With the coloured surface of the Backing (9) facing inside the stand, connect the Backing to the Base and Uprights with 22 nails in the pattern shown.

Avec la surface colorée de l'endos (9) qui fait face à l'intérieur du meuble, placez l'endos de niveau avec les montants et la base. Clouez l'endos au meuble à l'aide des 22 trous comme démontré.

Con la superficie coloreada de los (9) revestimientos del forro dentro del soporte, conecte el forro con la base y los montantes con 22 clavos en el patrón demostrado.

6

SCREW
#8 X 1/4"
8 PCS

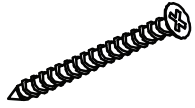

SOFA LEG
8 PCS

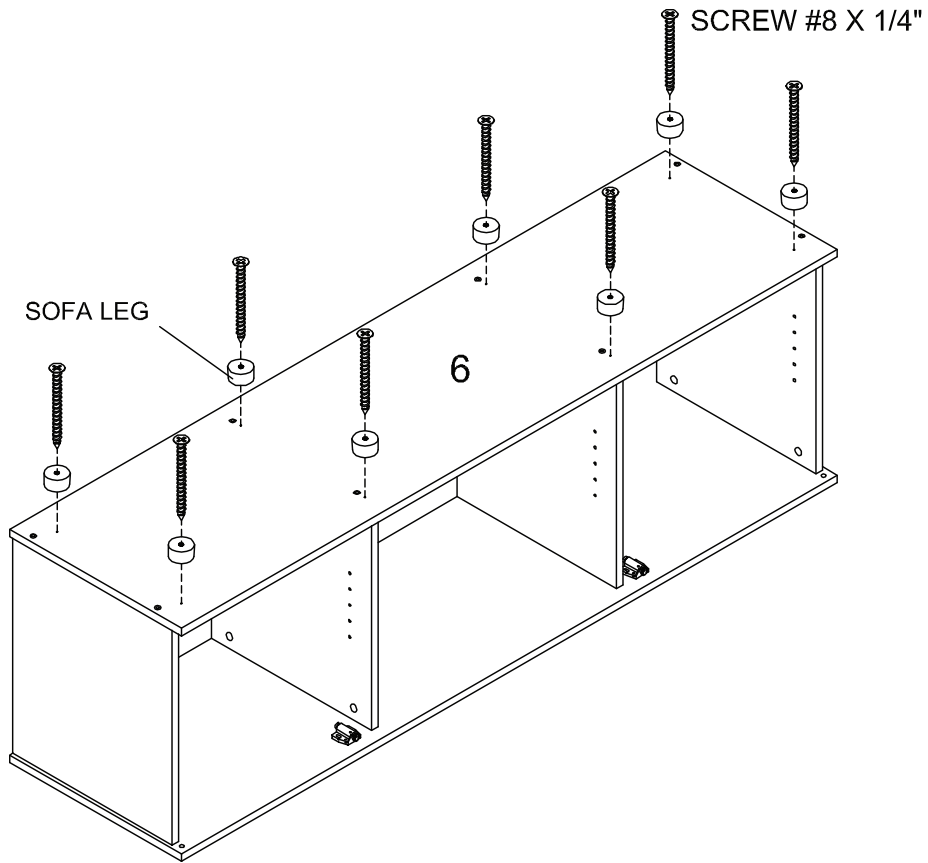
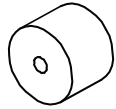

3

EURO BOLT
8 PCS

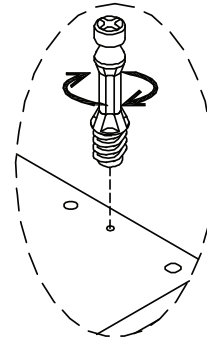

EURO BOLT

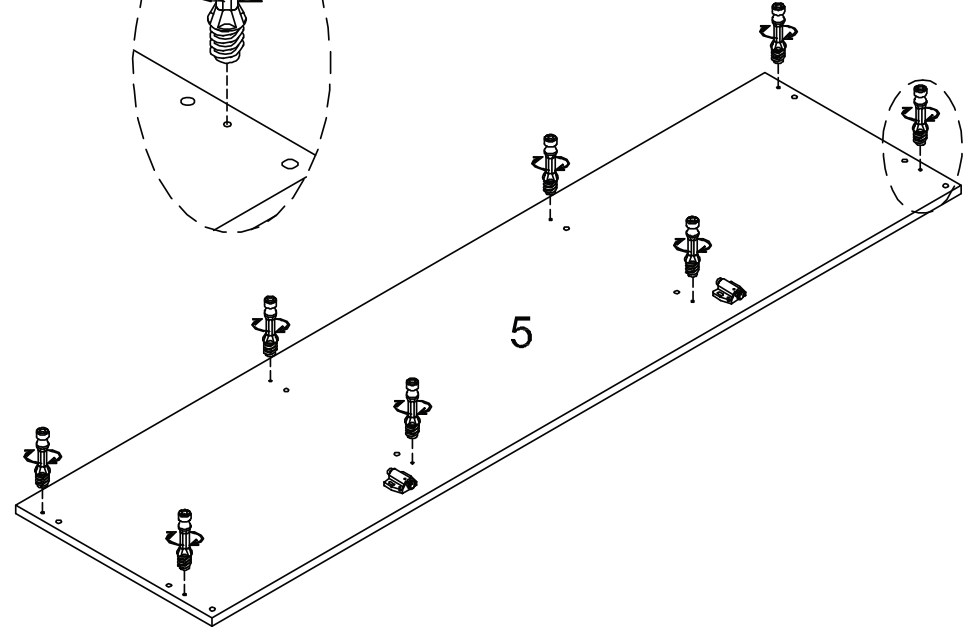

4

HOUSING
D15/12.5
8 PCS

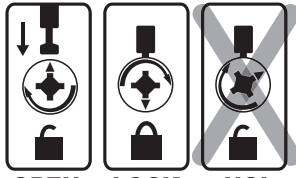
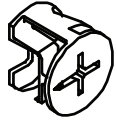

OPEN **LOCK** **NO!**



Make sure to **LOCK** cam!
Faire certain de verrouiller la came!
Asegúrese de Cam Lock!

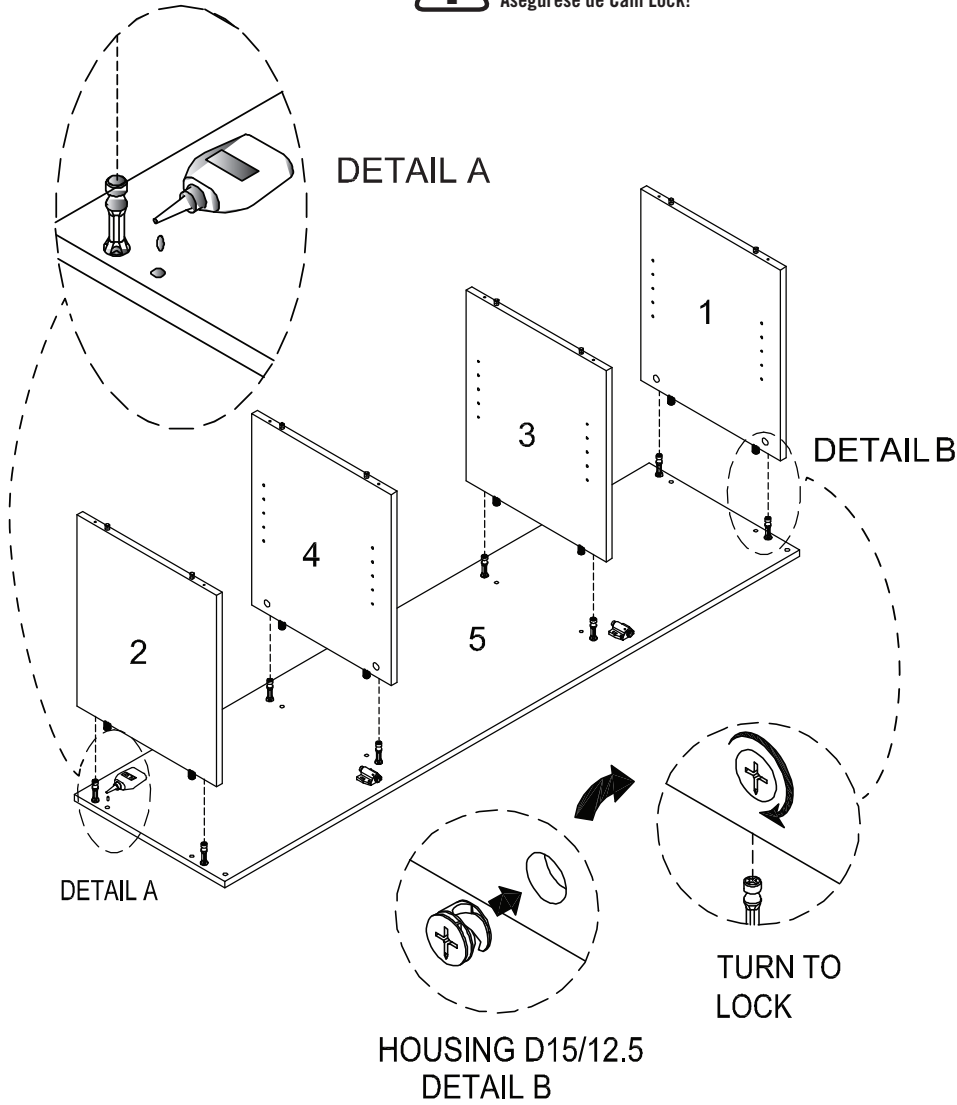

5

SCREW
M5.1 X 38
8 PCS

