

# Assembling Instruction

## Generating Drawings

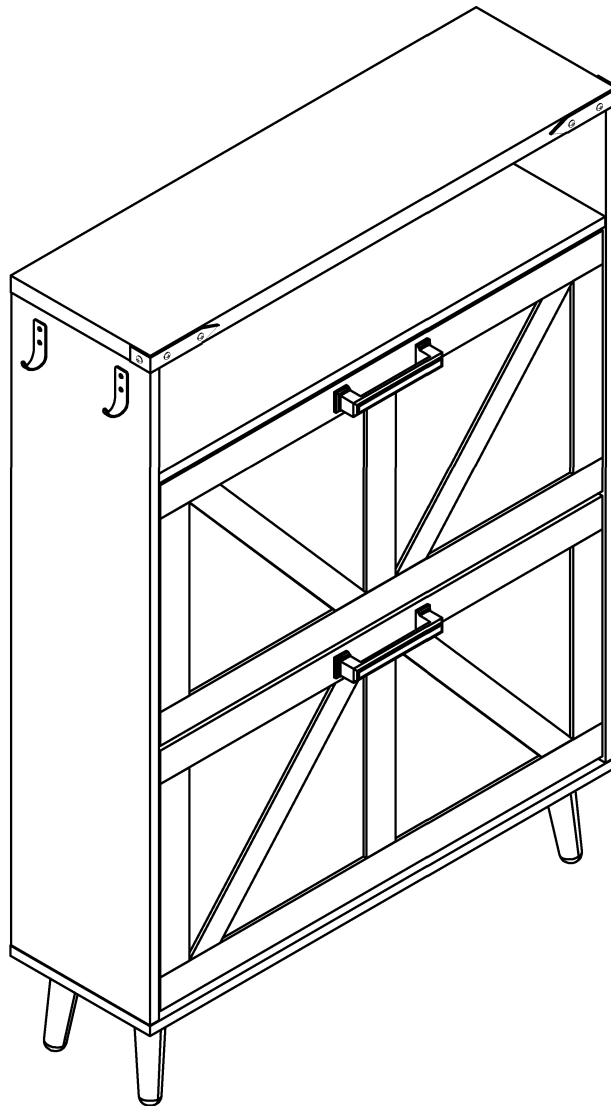

### ATTENTION

If there is any missing, please kindly send us messages to let us know the name of missing part regarding to the first page of instructions. Please also provide us your full address so we can send replacement to you as soon as possible. We are concerned about each customer's experience, if there is any loss or damage, please contact us at any time, we will provide effective solutions. Please attach your Order ID so that we can assist you better. Children have died from furniture tipover. To reduce the risk of furniture tipover. ALWAYS install tipover restraint provided.



# General Assembly Guidelines

- I. Ensure that all Parts and hardware are available before beginning assembly.
- II. Follow each step carefully to ensure the proper assembly of this Product.
- III. Two People are recommended for ease in the assembly of this Product.
- IV. The three main types of hardware used to assemble this Product are : wood dowels , screws and bolts.
- VI. A Phillips head screwdriver is required for the assembly of this Product .

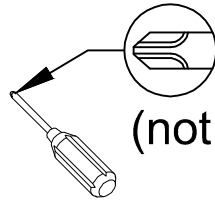

(not included)

- VII. Power tools should not be used to assemble this Product .

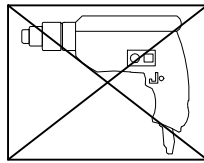

## CAM LOCK/BOLT FASTENING INTRODUCTION

(You will use it during assembly)

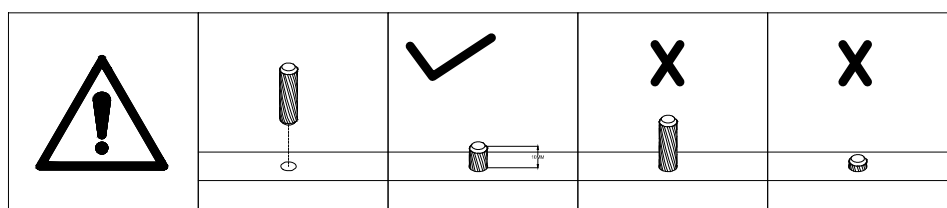
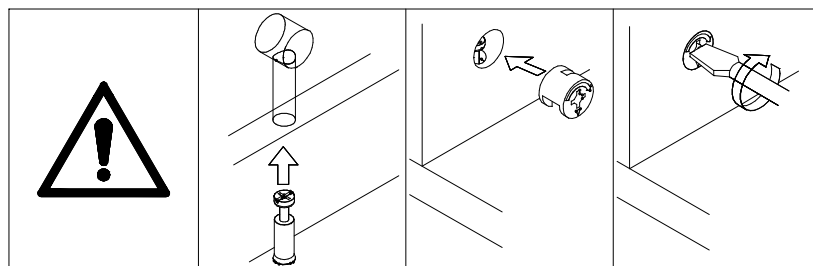
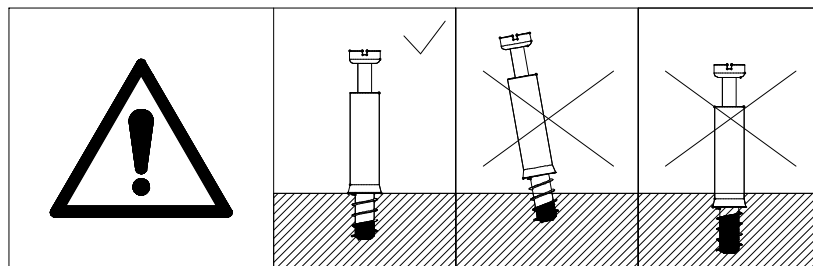

# Parts List

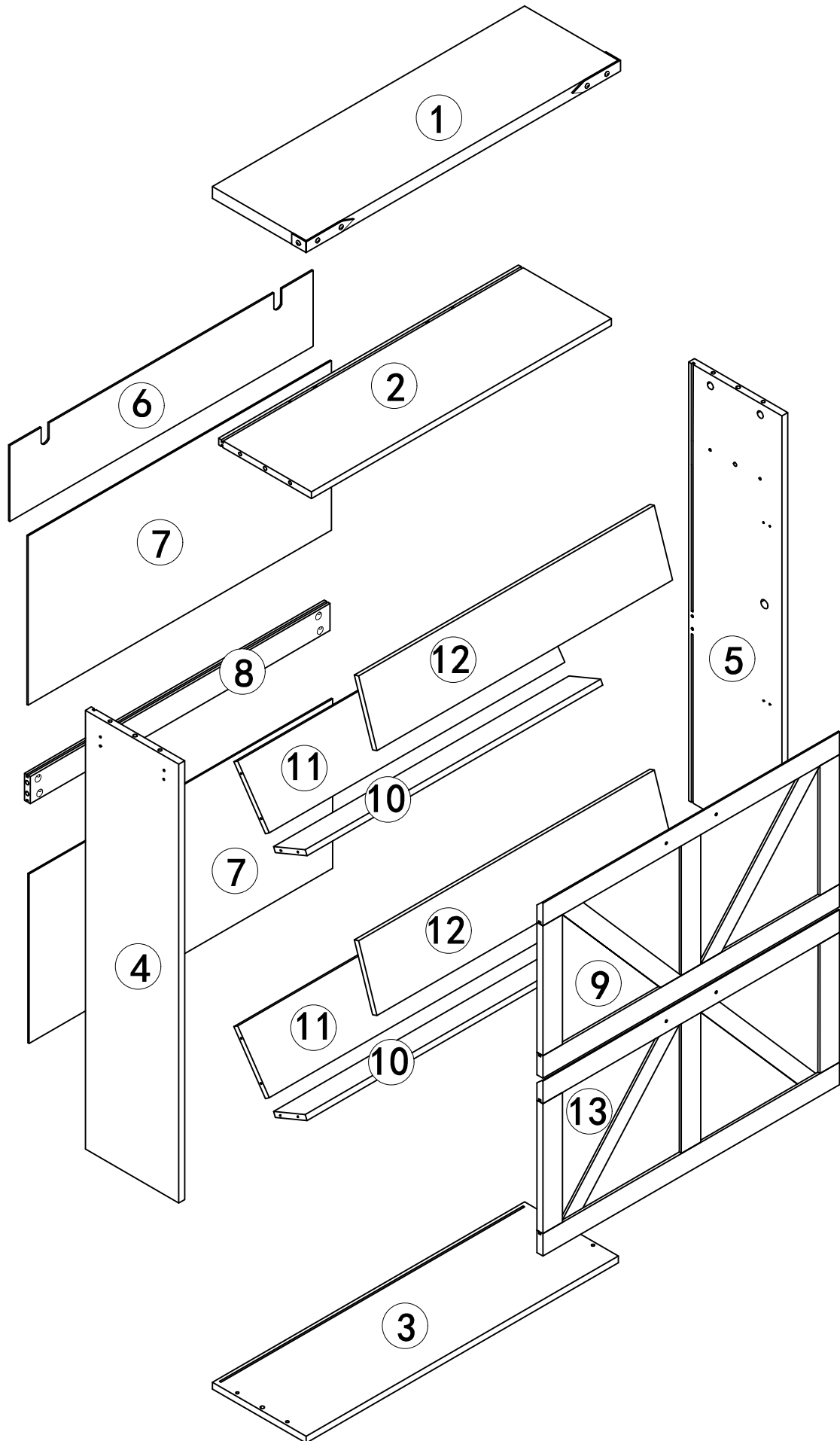

# HARDWARE PACK CONTENT

**A**

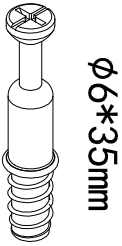

12X+1

**B**

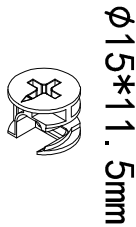

12X+1

**C**

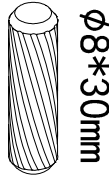

6X+1

**D**



4X+1

**E**

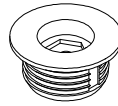

4X

**F**

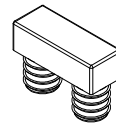

4X

**G**



4X+1

**H**

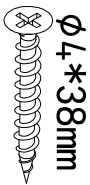

2X

**I**



2X

**J**



2X

**K**

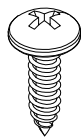

4X

**L**



16X+2

**M**

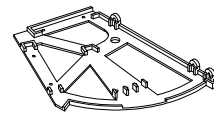

2X

**N**

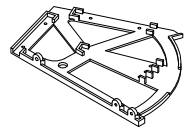

2X

**O**



2X

**P**



4X

**Q**



12X+2

**R**

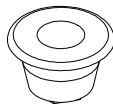

4X

**S**



24X+2

**T**

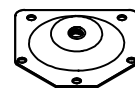

4X

**U**



4X

**V**



8X+1

**W**

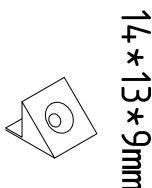

8X+1

**X**

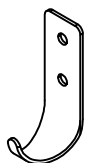

2X

**Y**



4X

**Z**





1X

# Step 1

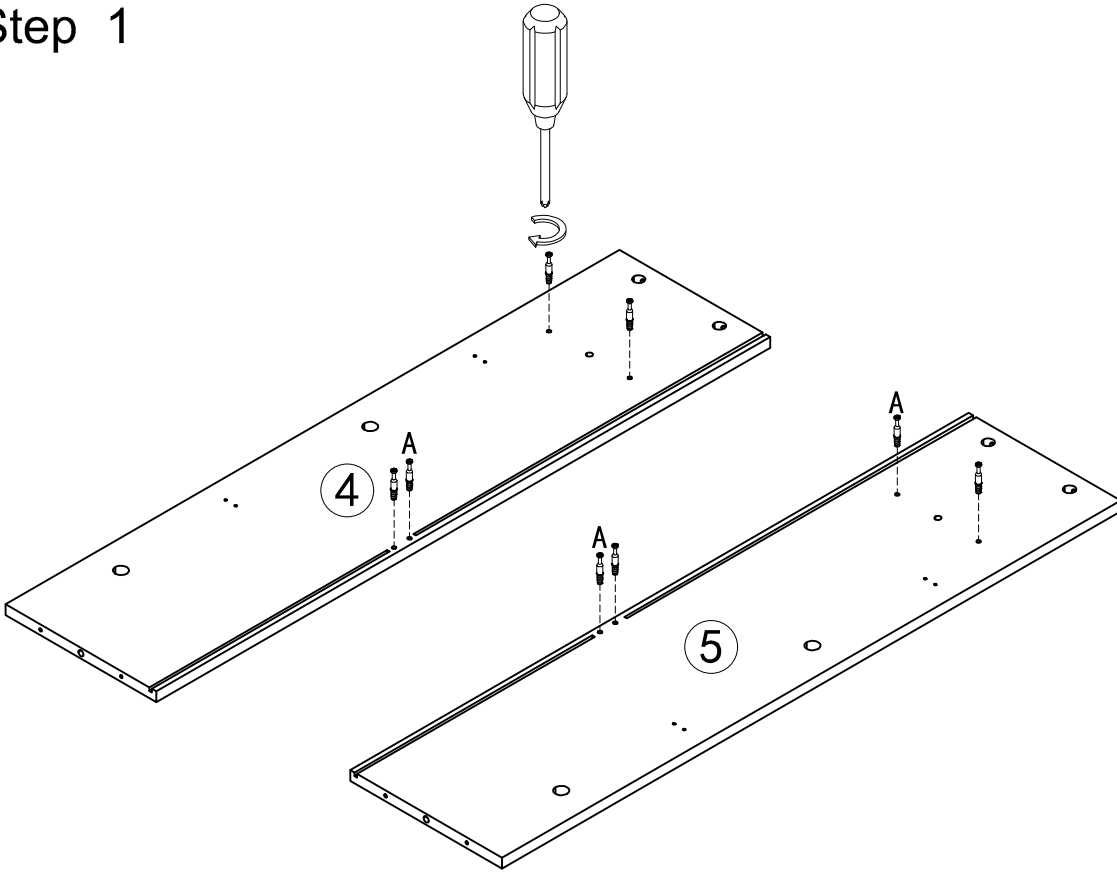
A

X8



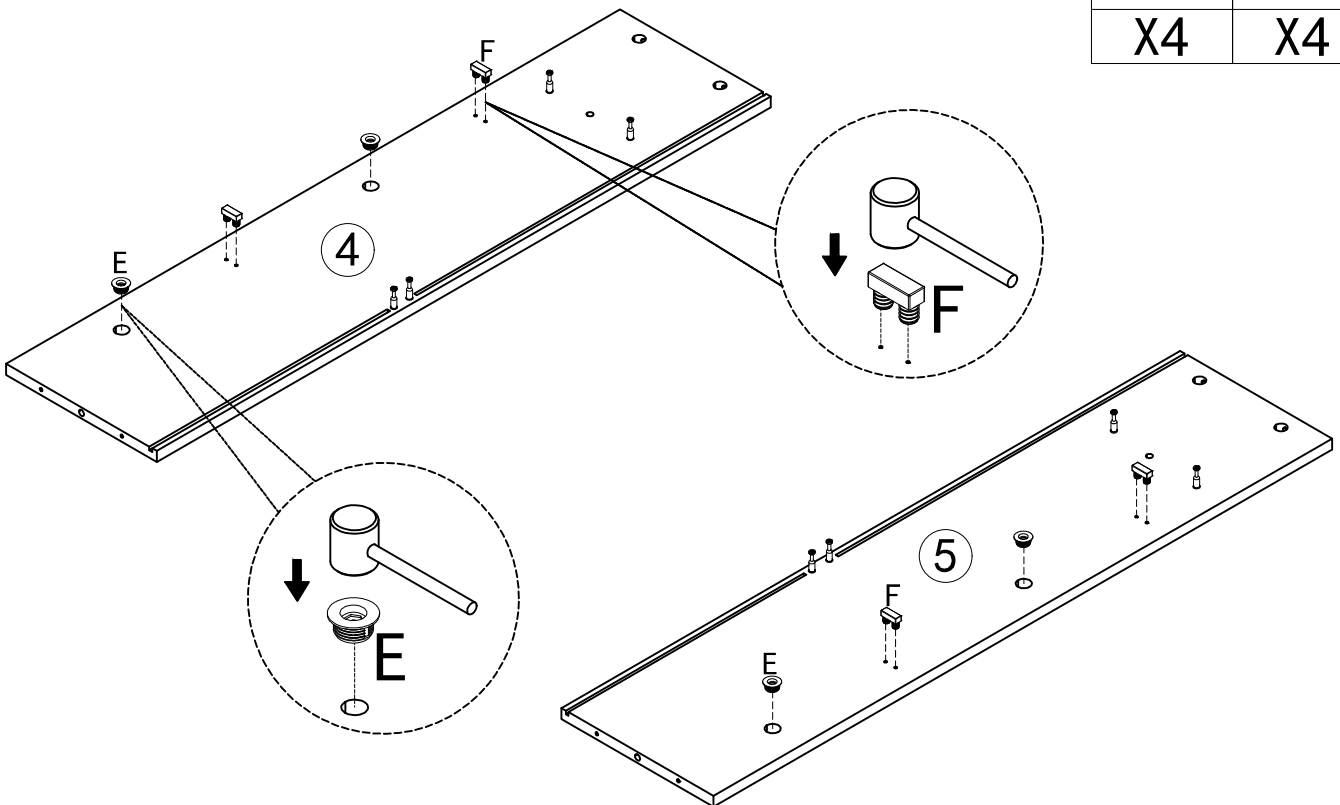

# Step 2

E	F
	
X4	X4



### Step 3

B	C
	
X4	X1

NOTE: Make sure board slots #4 #8 and #2 are on the same side

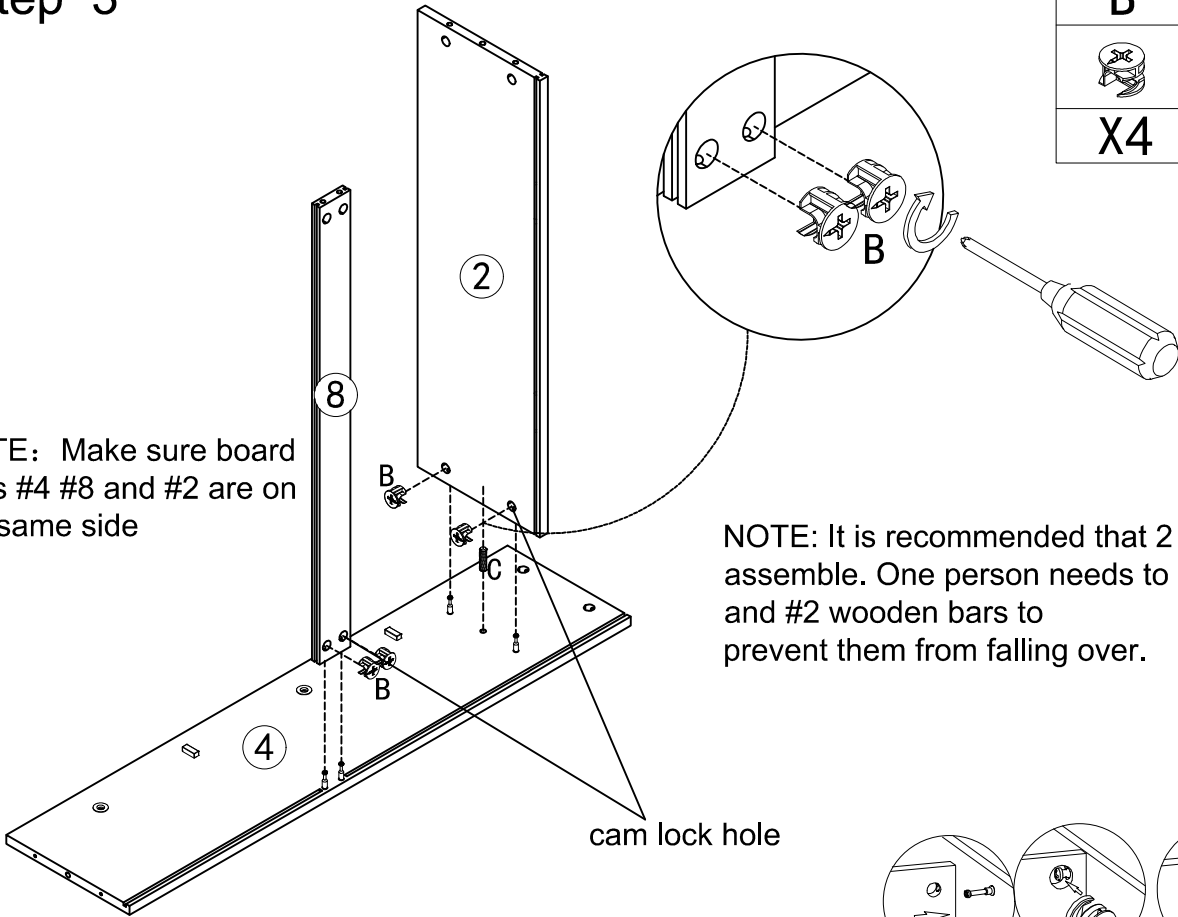

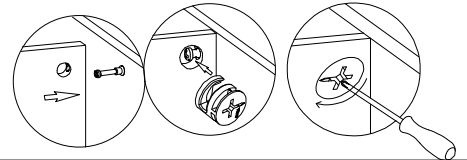

NOTE: It is recommended that 2 people assemble. One person needs to hold the #8 and #2 wooden bars to prevent them from falling over.

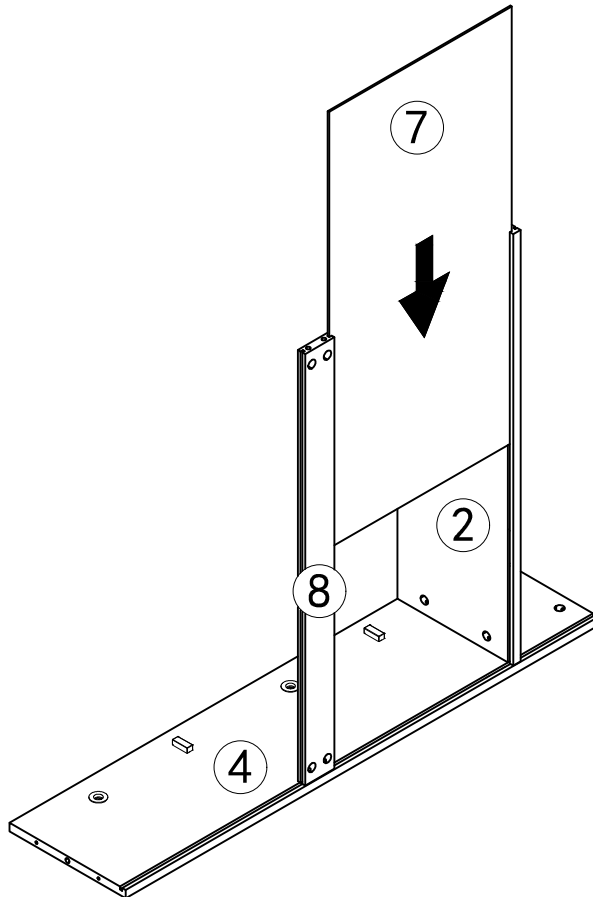

### Step 4



# Step 5

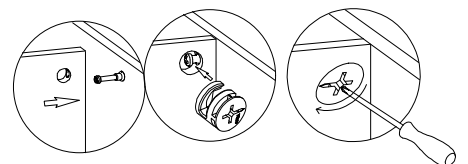
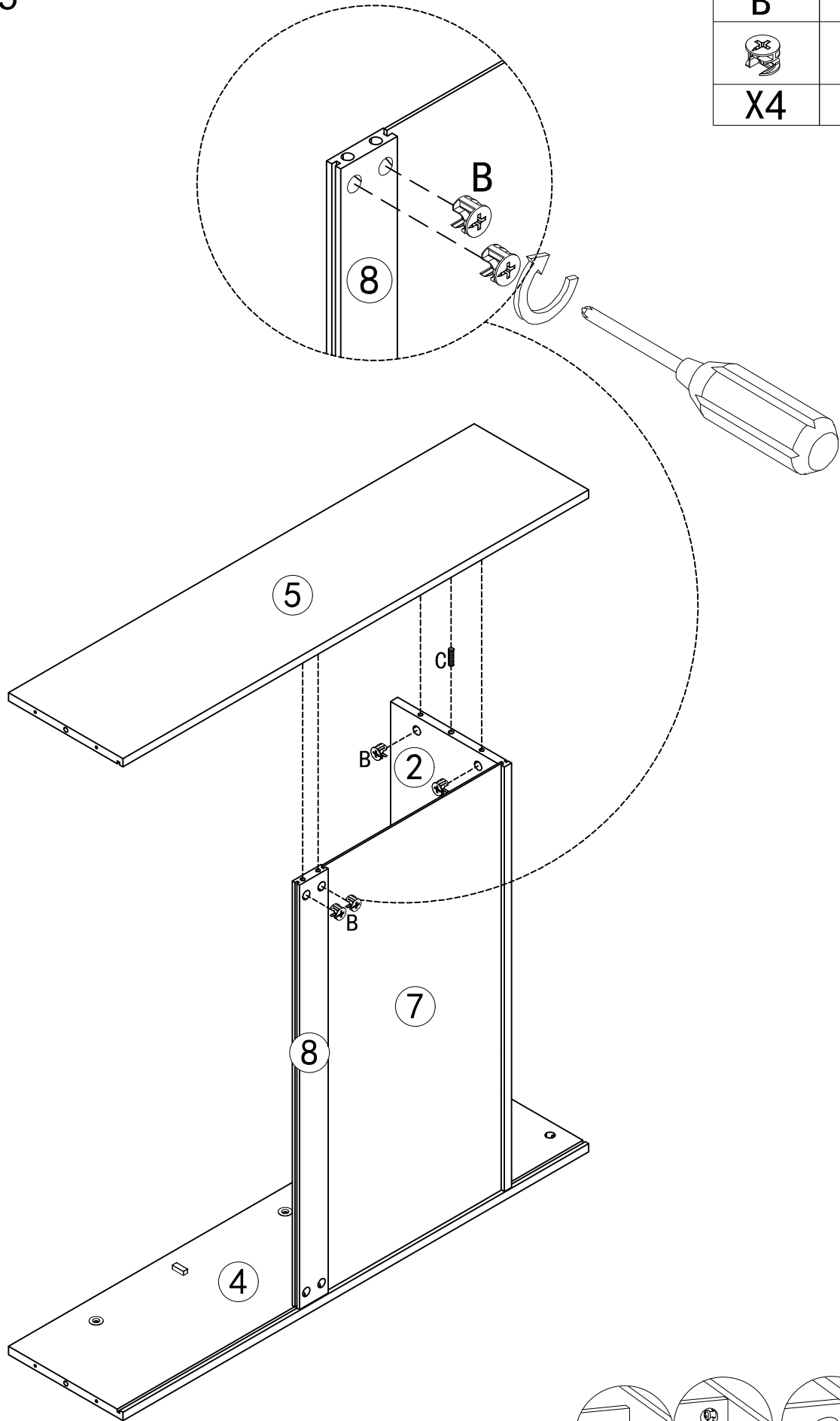

B	C
	
X4	X1

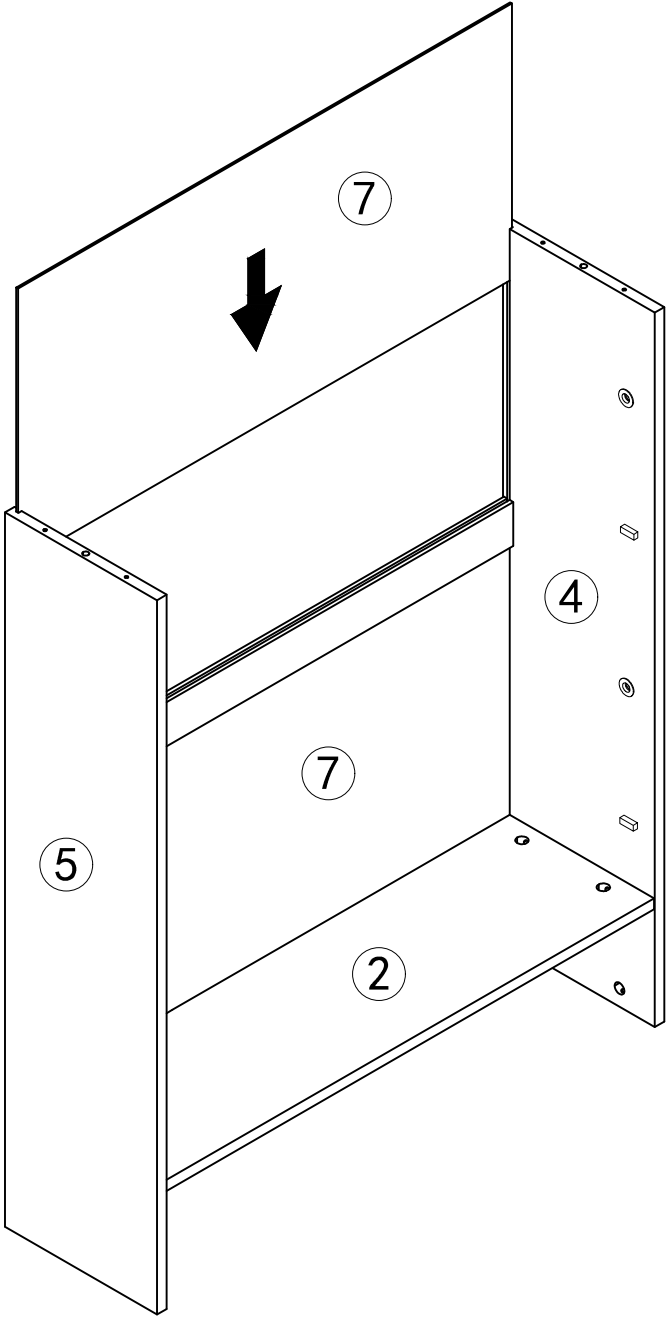

Step 6



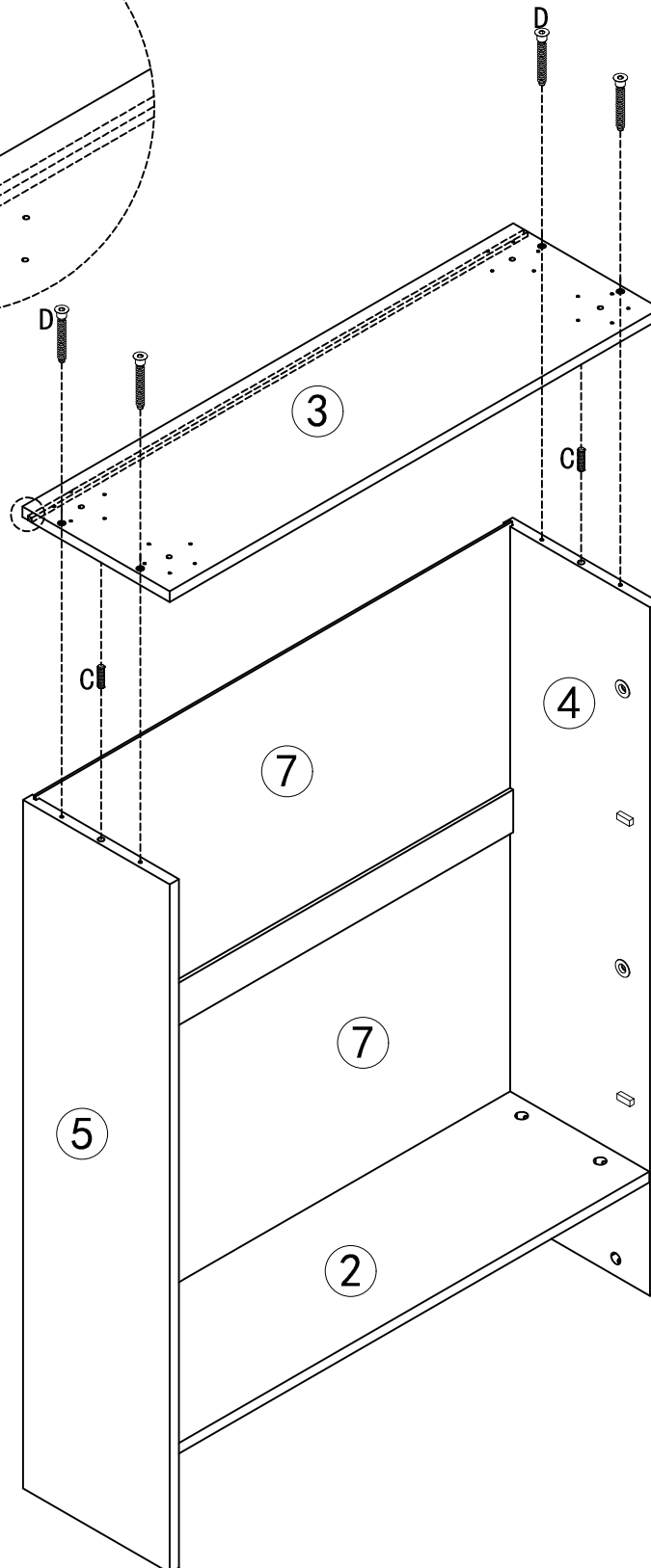
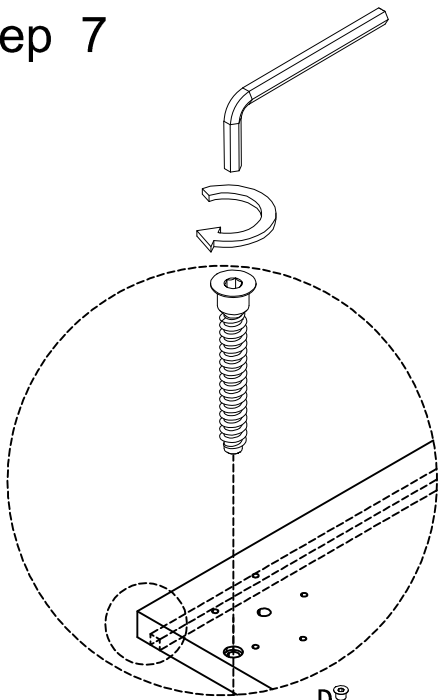

# Step 7

C	D
	
X2	X4



# Step 8

S	T
	
X20	X4

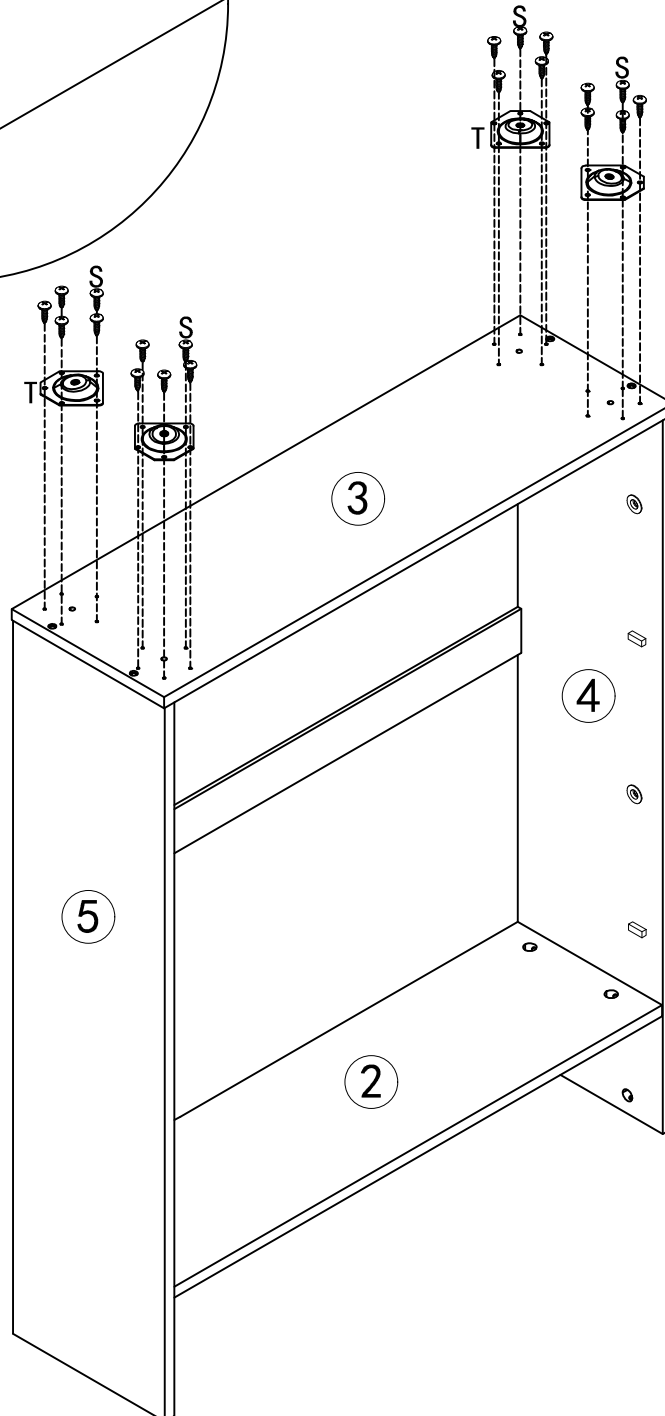
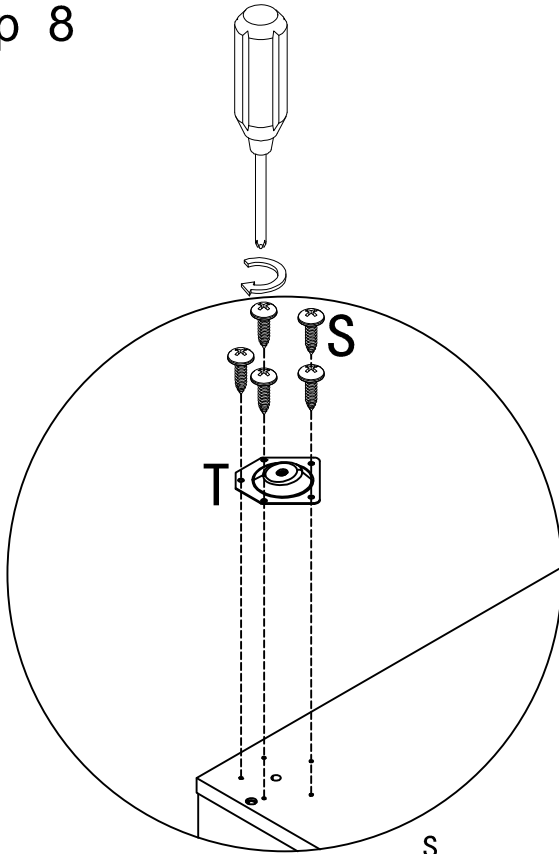

# Step 9

U

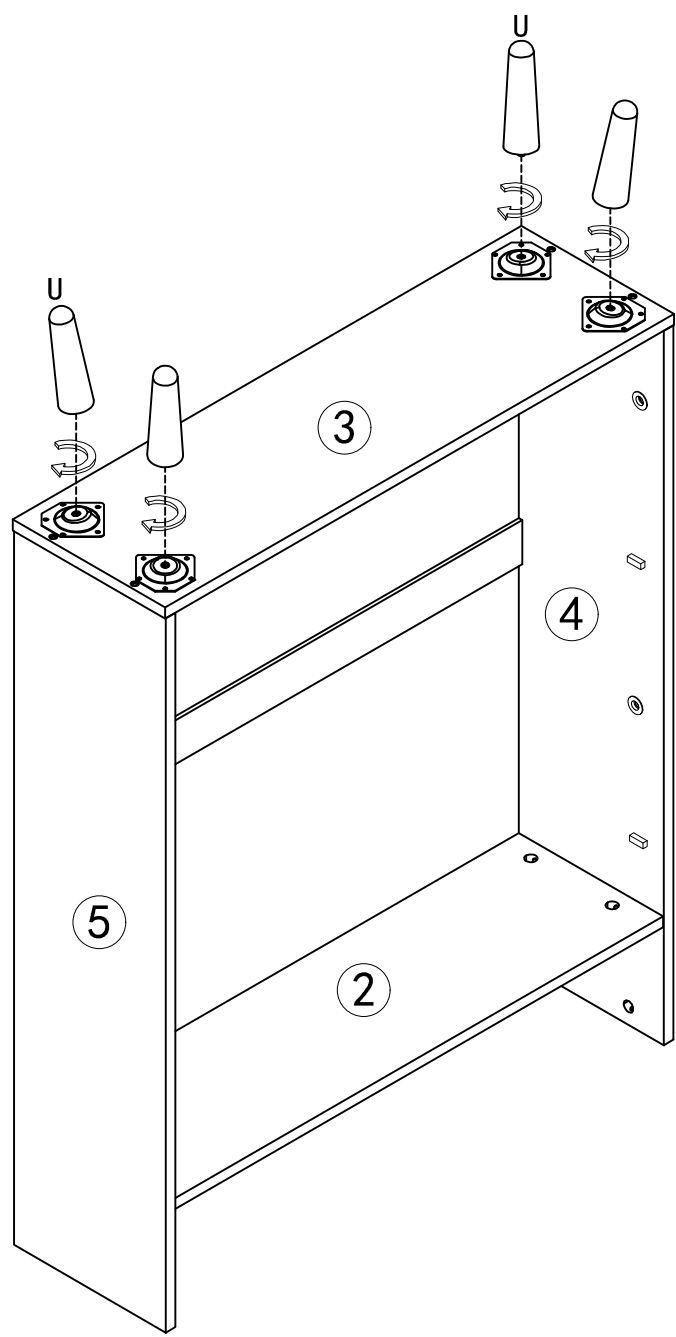
X4





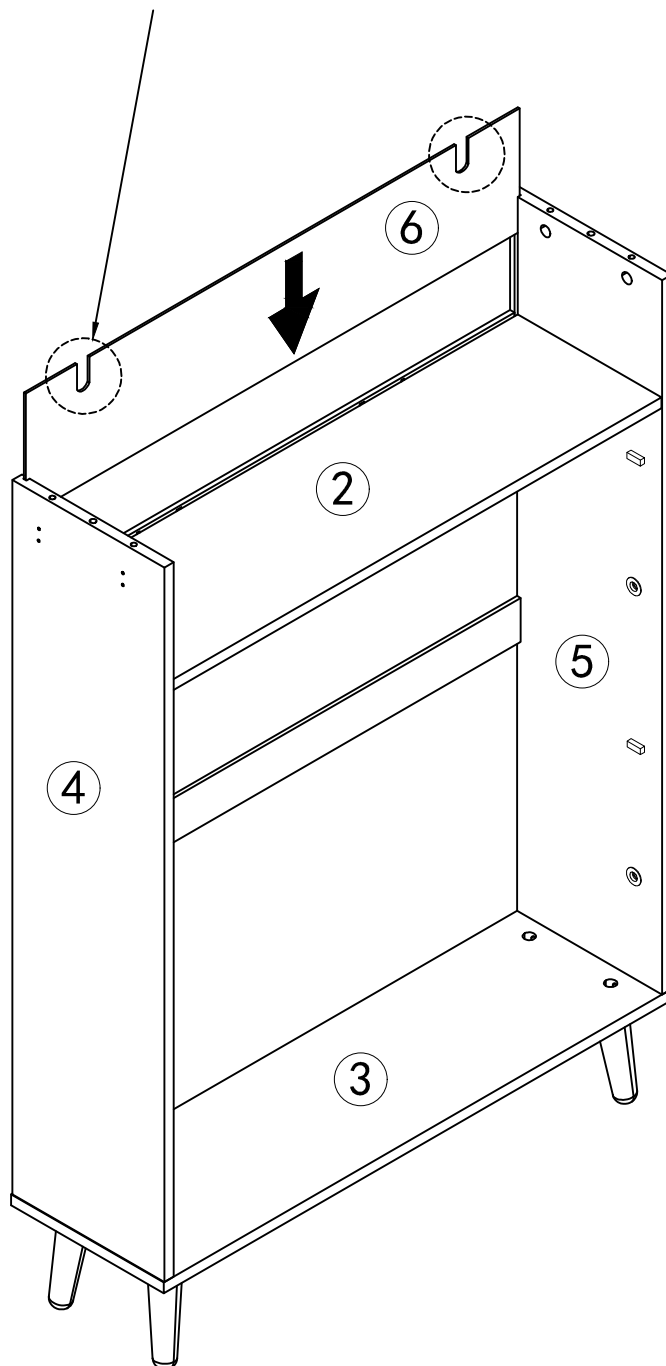

# Step 10

NOTE: The U-shaped hole on the #6 board faces upwards



# Step 11

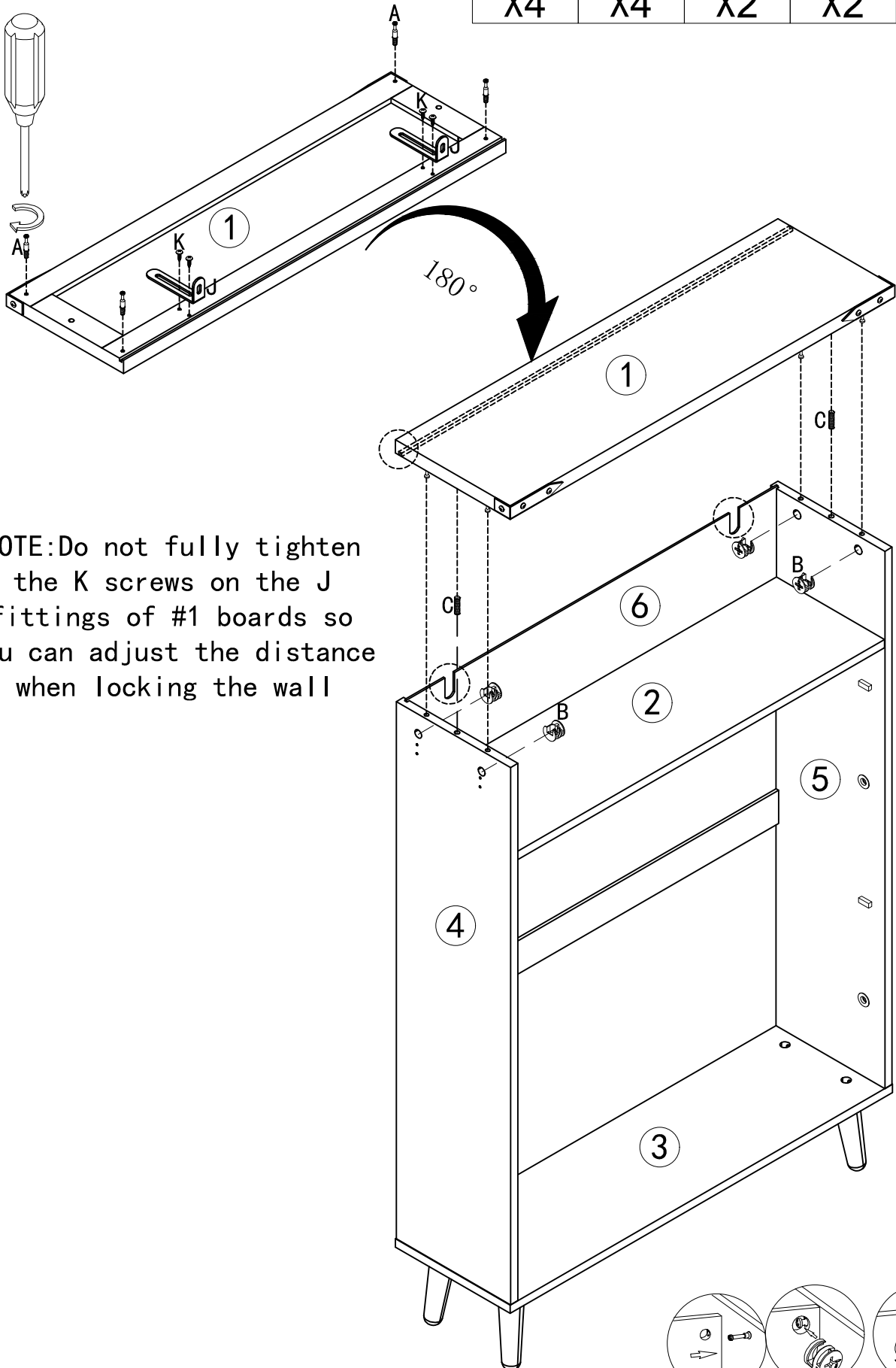

A	B	C	J	K
				
X4	X4	X2	X2	X4

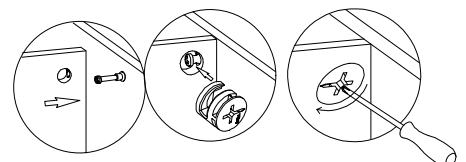

NOTE: Do not fully tighten the K screws on the J fittings of #1 boards so you can adjust the distance when locking the wall



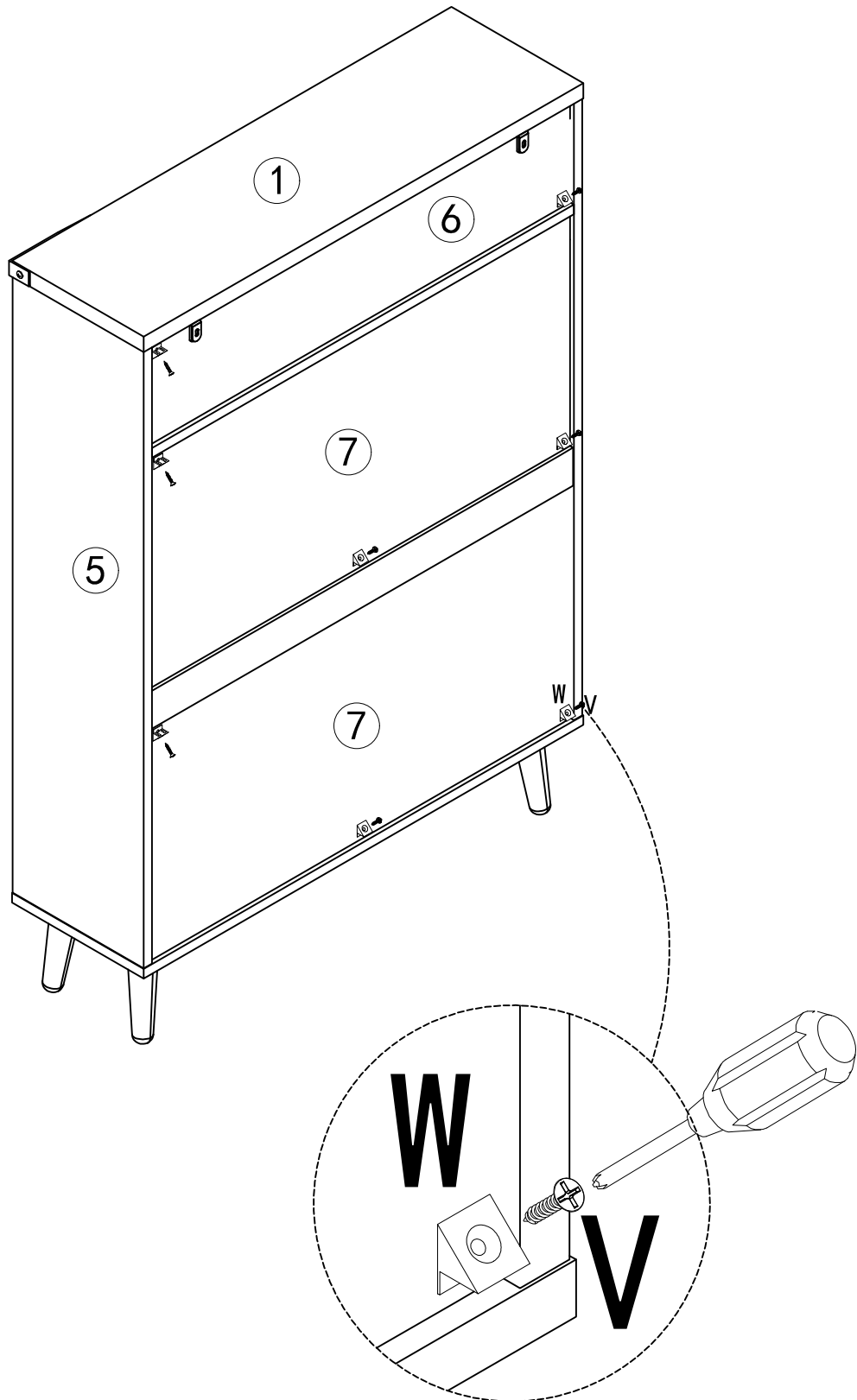

# Step 12

V	W
	
X8	X8



NOTE: Please install the #W back panel buckles staggered according to the diagram.

# Step 13

H	I
	
X2	X2

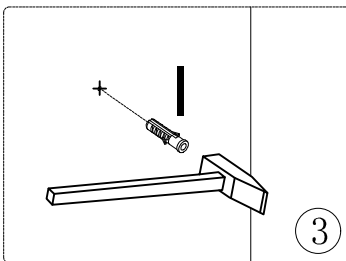
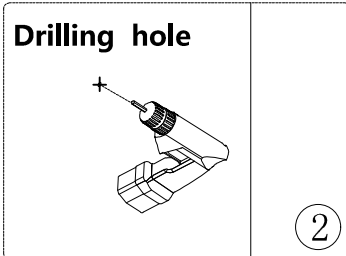
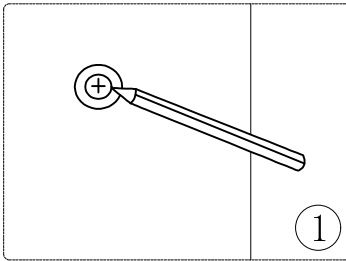

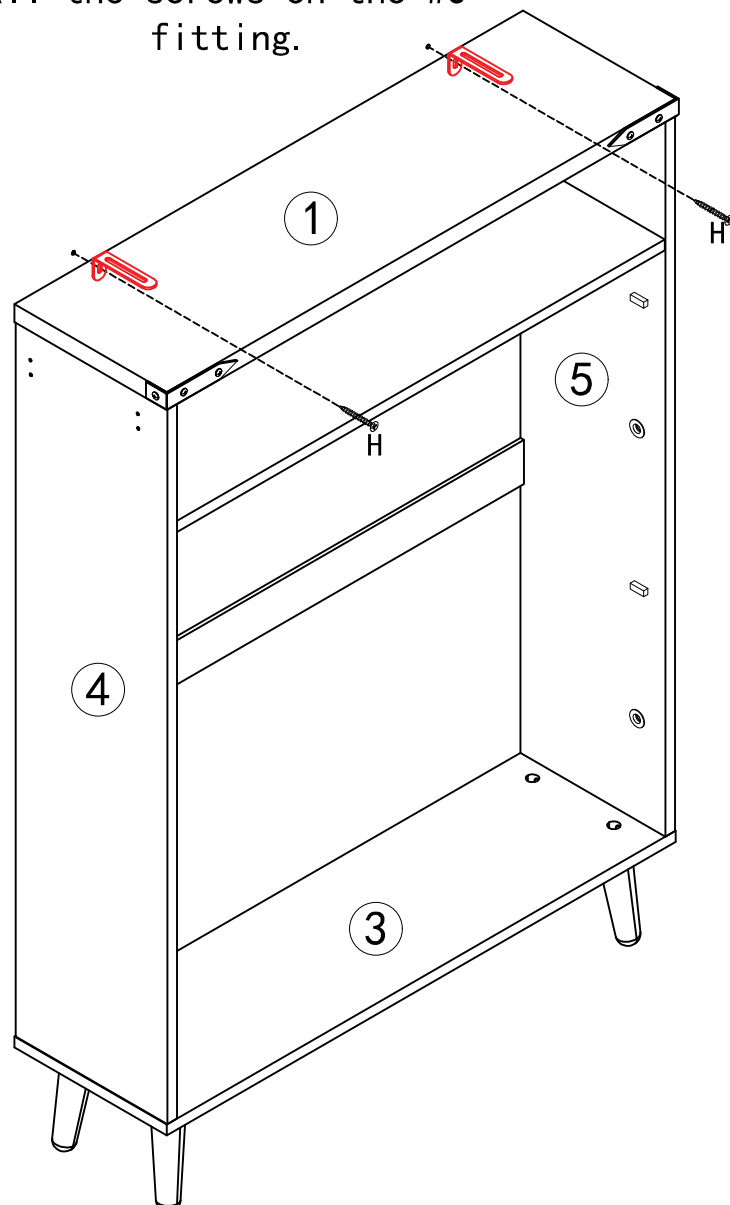
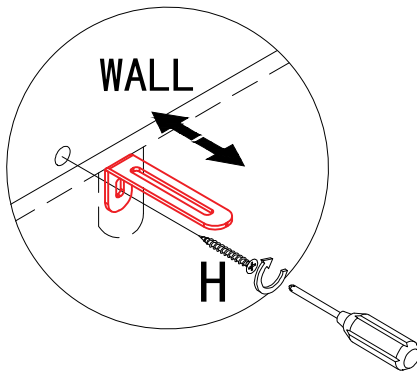

1. Mark the drill position on the wall with pencil.
2. Make 2 holes with a bit at the marked locations.
3. Tap the wall anchor (I) into the drilled holes with a hammer.
4. Fixed the cabinet to the wall with screws (H)

NOTE: According to the distance between the cabinet and the wall, adjust the #J fitting to the appropriate position, and then tighten all the screws on the #J fitting.



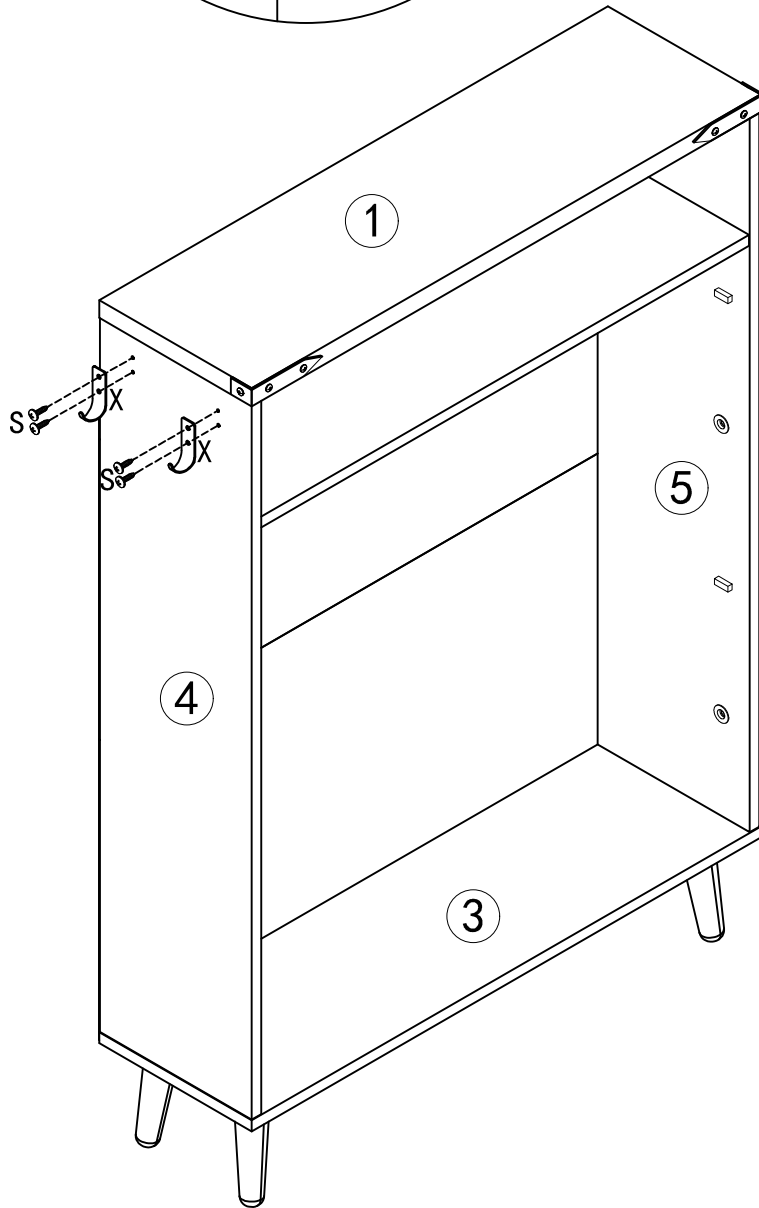
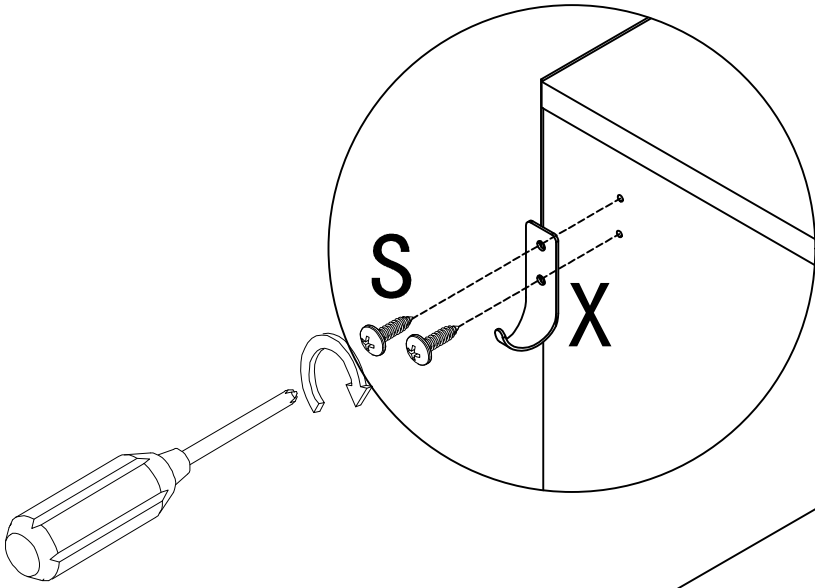

# Step 14

S	X
	
X4	X2



# Step 15

L	M	N
		
X8	X2	X2

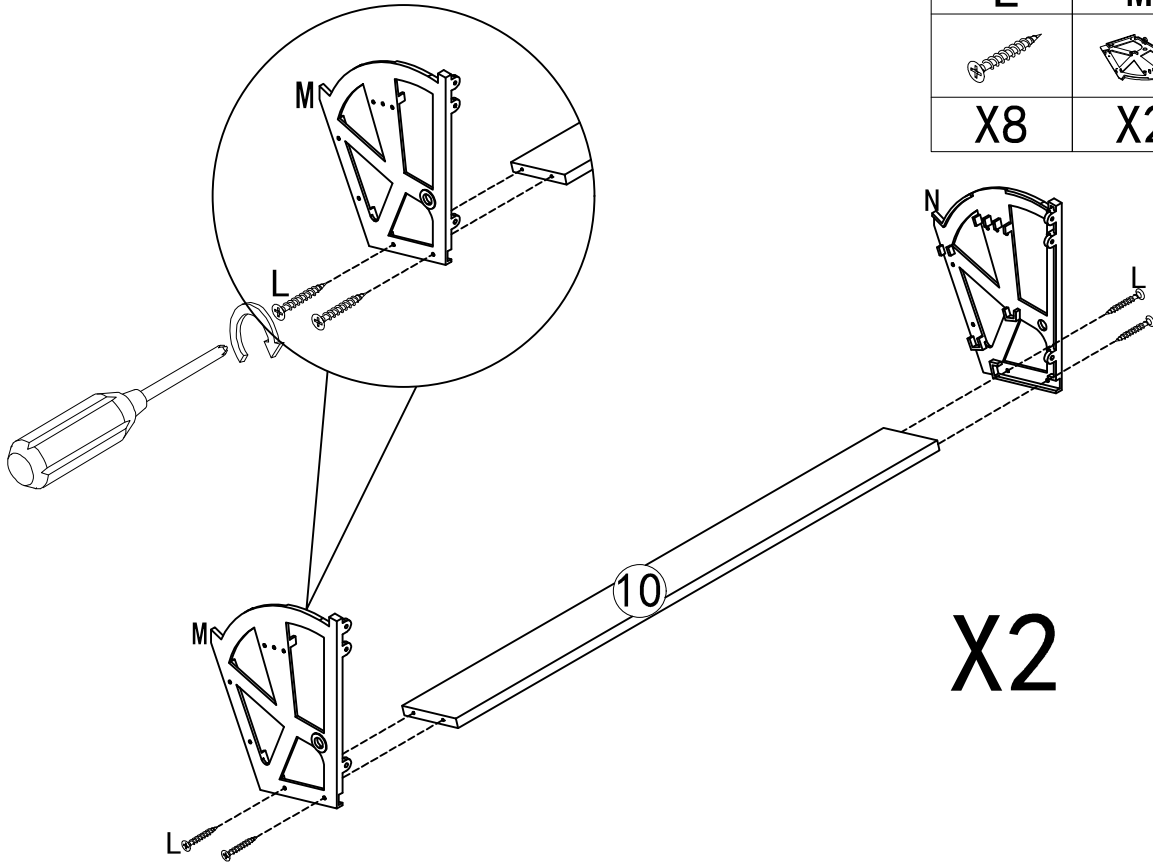

X2

# Step 16

Q

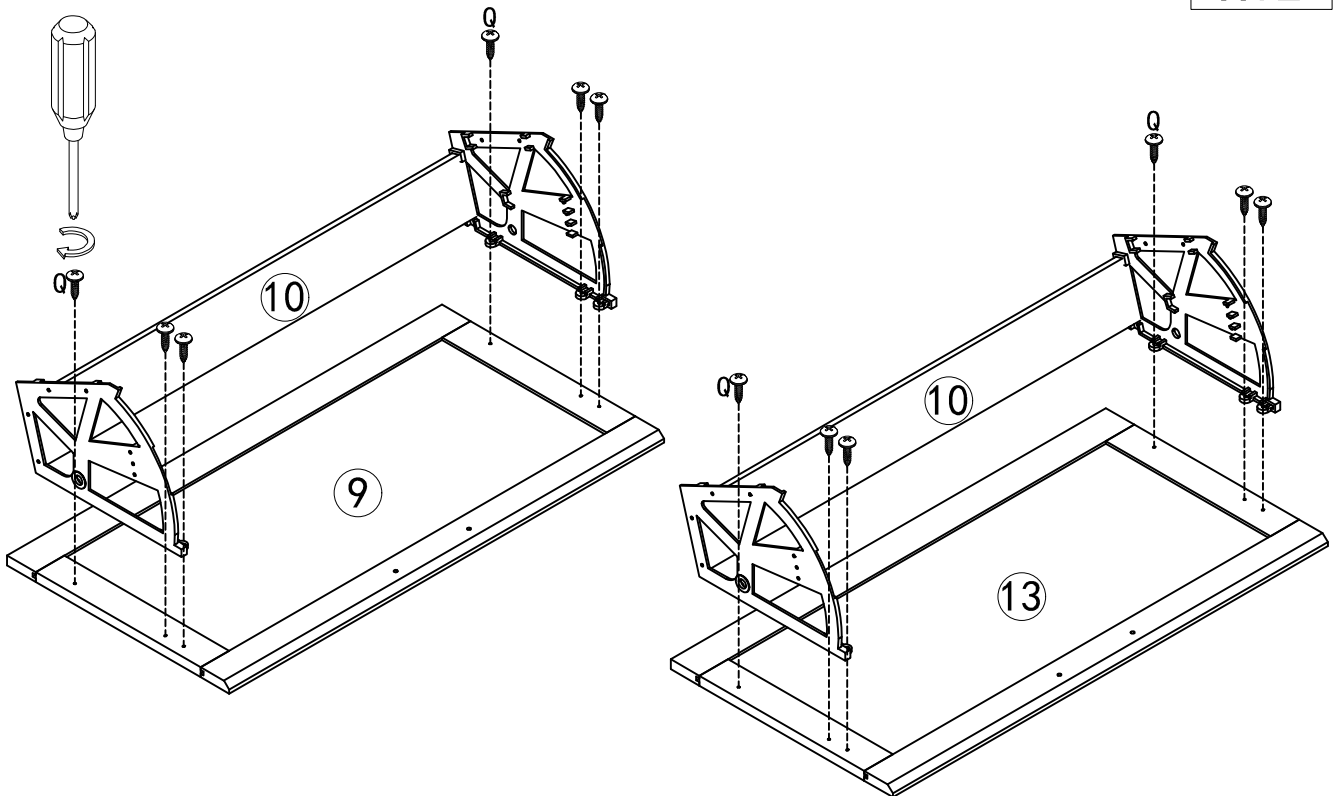
X12



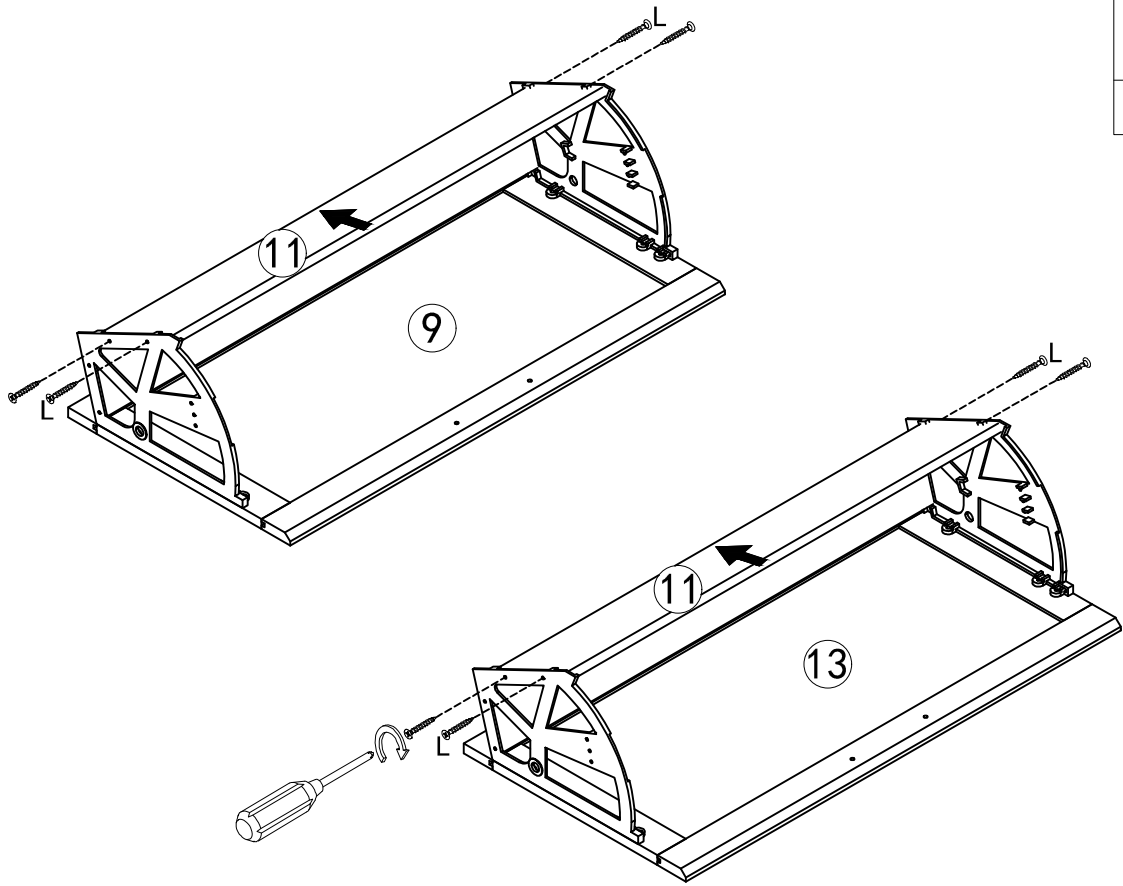

# Step 17

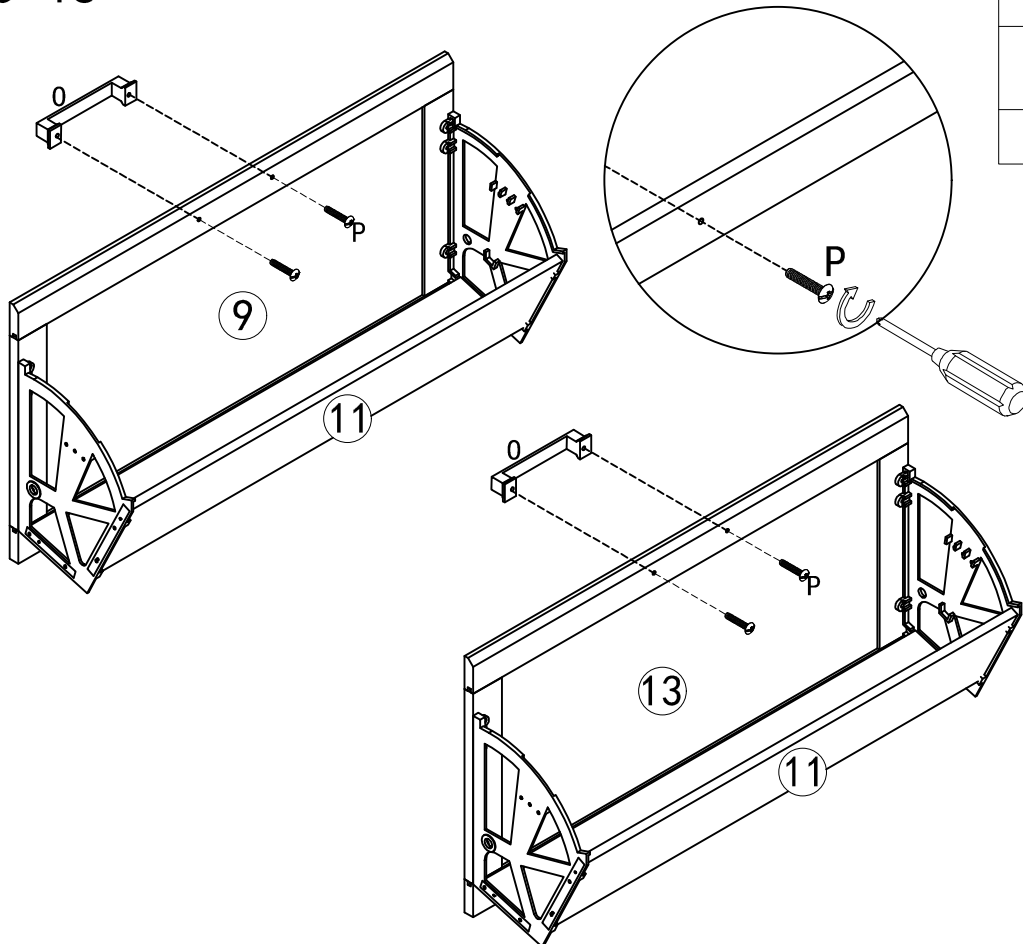

L

X8



# Step 18



O	P
	
X2	X4

# Step 19

NOTE: The door requires 2 people to assemble. You must place the door's 米 shaped pattern according to the diagram, or install the door according to your own pre-arranged pattern, otherwise it will affect the beauty of the shoe cabinet.

G	R
	
X4	X4

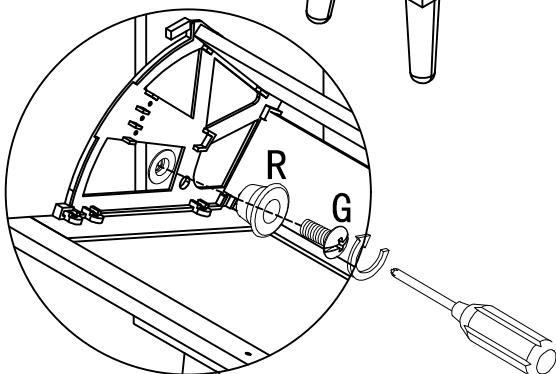
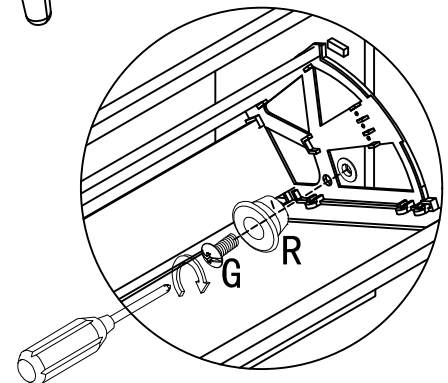
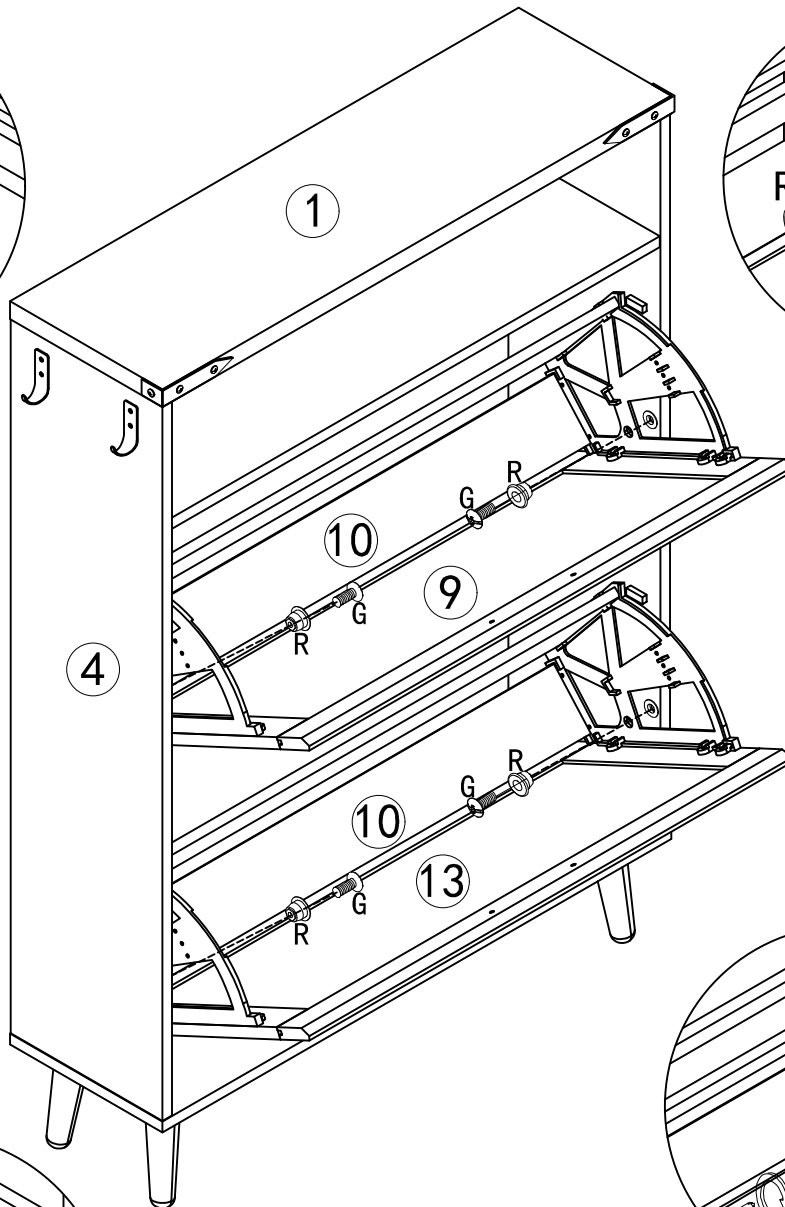
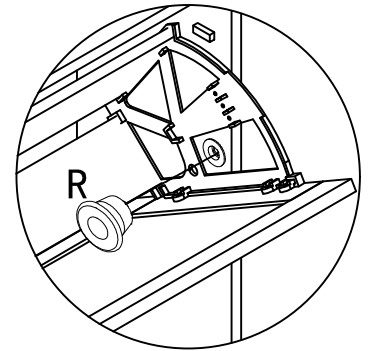
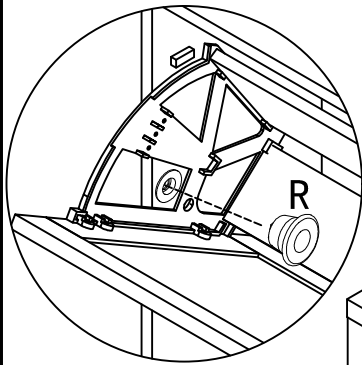
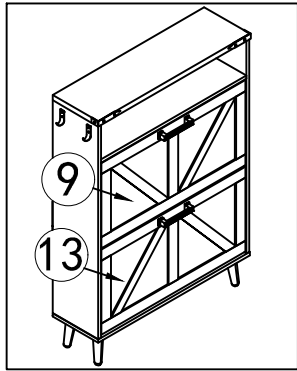

## Step 20

Note: The #12 board only needs to be inserted according to the position shown in the picture, no screws are required.

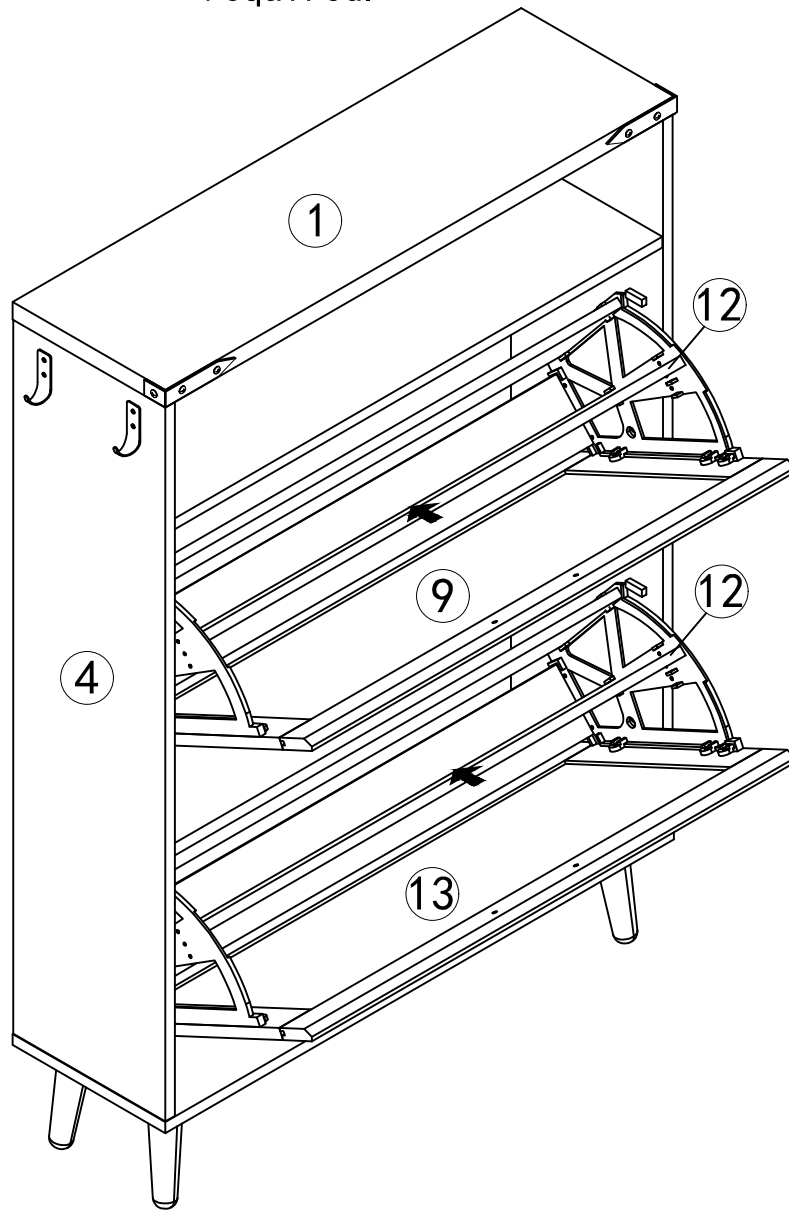

### Adjustable shelf for various size of shoes

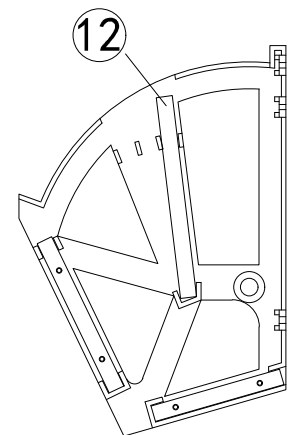
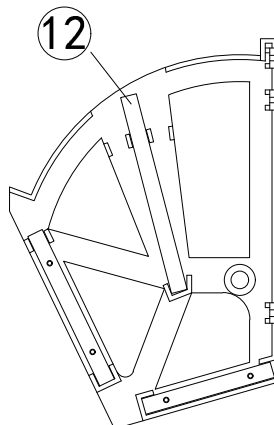
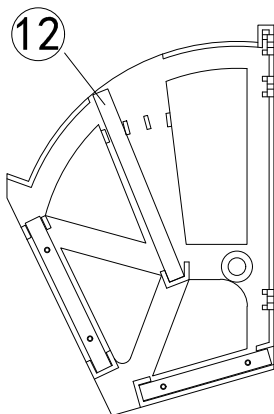

# Step 21

Y
O
X4

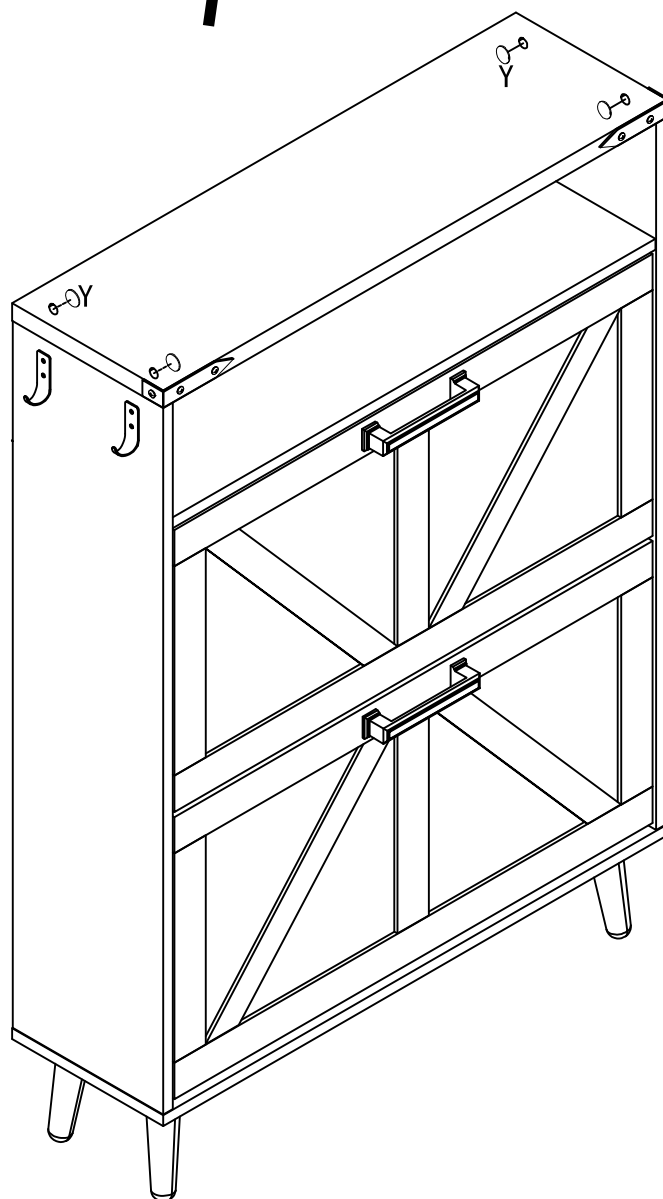
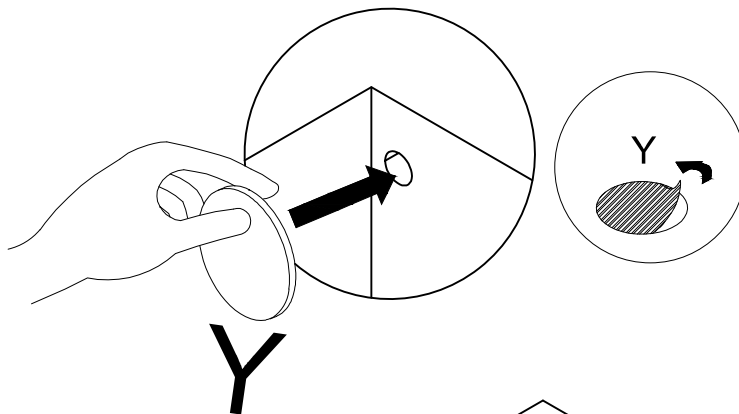

Step 22

