

ASSEMBLY INSTRUCTIONS

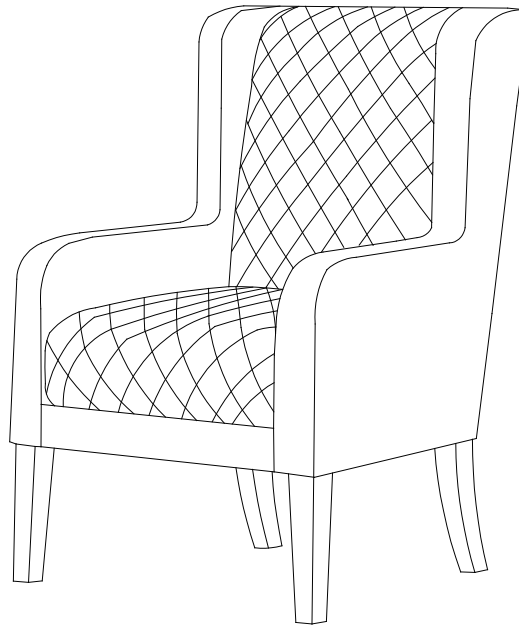



WINGBACK ACCENT CHAIR





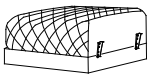

COMPLETED

WINGBACK ACCENT CHAIR ASSEMBLY

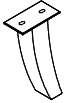
PART LIST

PART	DRAWING	DESCRIPTION	QTY
A		SEAT	1PC
B		LEFT ARM	1PC
C		RIGHT ARM	1PC
D		BACKREST	1PC

PART	DRAWING	DESCRIPTION	QTY
E		FRONT LEG	2PCS
F		BACK LEG	2PCS
1		BOLT	8PCS
2		FLAT WASHER	8PCS
3		ALLEN KEY	1PCS

NOTES:

1. CHECK CAREFULLY FOR SMALL PARTS WHICH MAY COME LOOSE DURING SHIPMENT.
2. REMOVE ALL COMPONENTS FROM THE PACK AND PLACE ON A CLEAN, SOFT SURFACE TO ASSEMBLE.
3. UNITS SHOULD BE ASSEMBLED BY TWO OR MORE PEOPLE.
4. DO NOT OVER-TIGHTEN SCREW/ BOLTS UNTIL ASSEMBLY IS COMPLETED.
5. WITH USE, SCREW MAY BE COME LOOSE & MUST BE TIGHTENED PERIODICALLY.

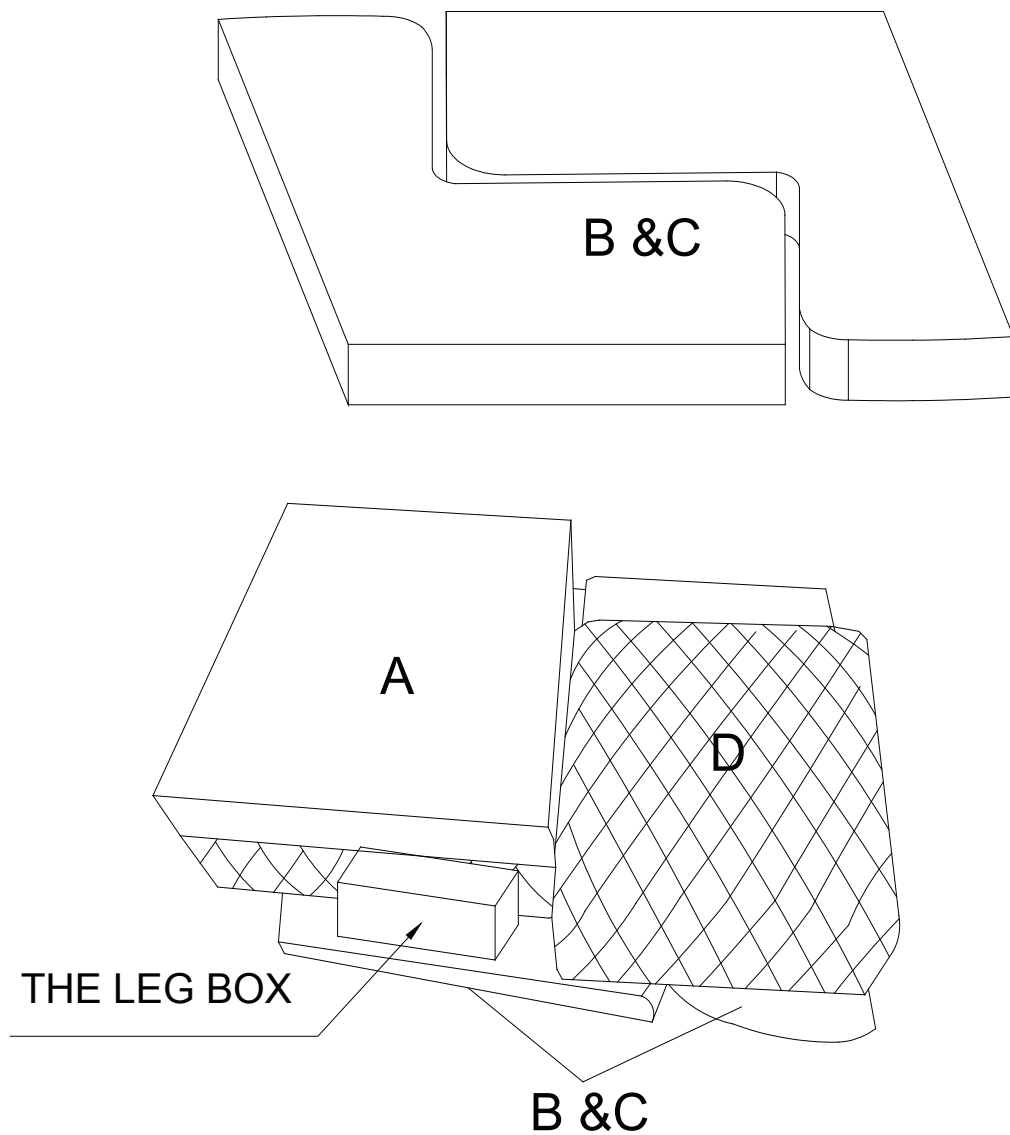

THE PARTS ARE LOCATED INSIDE THE BOX AS BELOW:

**NOTES:**

1. CHECK CAREFULLY FOR SMALL PARTS WHICH MAY COME LOOSE DURING SHIPMENT.
2. REMOVE ALL COMPONENTS FROM THE PACK AND PLACE ON A CLEAN, SOFT SURFACE TO ASSEMBLE.
3. UNITS SHOULD BE ASSEMBLED BY TWO OR MORE PEOPLE.
4. DO NOT OVER-TIGHTEN SCREW/ BOLTS UNTIL ASSEMBLY IS COMPLETED.
5. WITH USE, SCREW MAY BE COME LOOSE & MUST BE TIGHTENED PERIODICALLY.

ASSEMBLY INSTRUCTIONS

WINGBACK ACCENT CHAIR

Step 1: Attach Seat(A) to Left arm(B) and Right arm(C) .

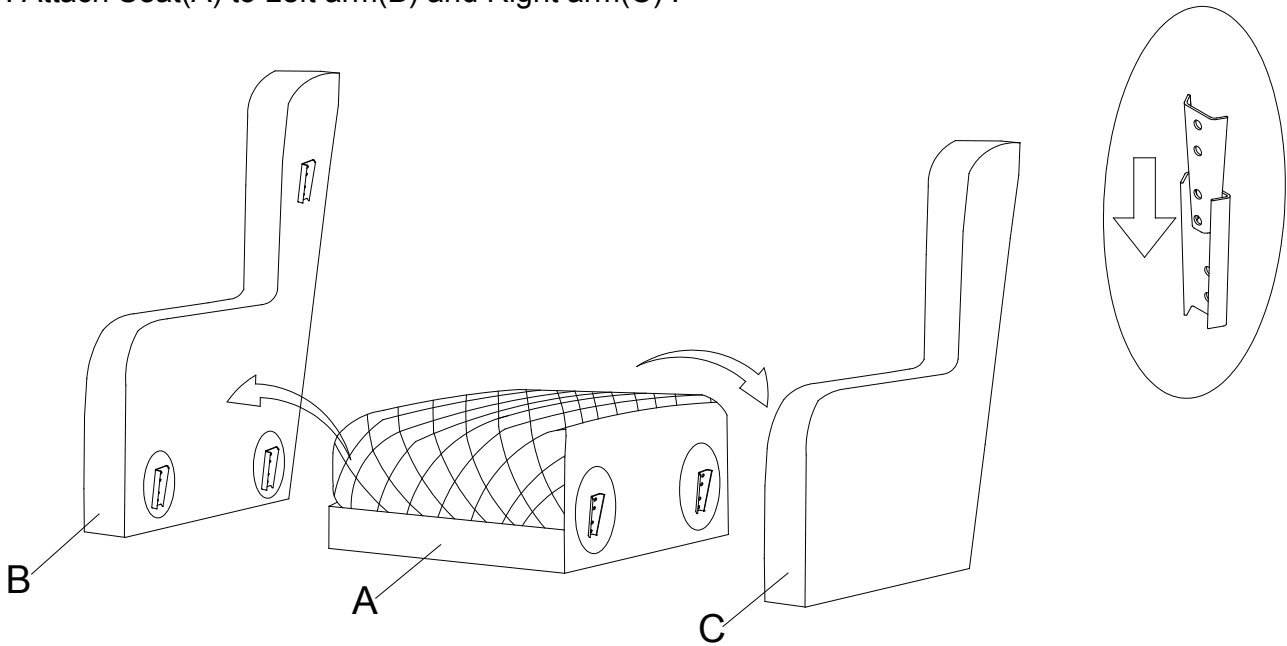

Step 2: Attach Backrest(D) to Left arm(B) and Right arm(C)

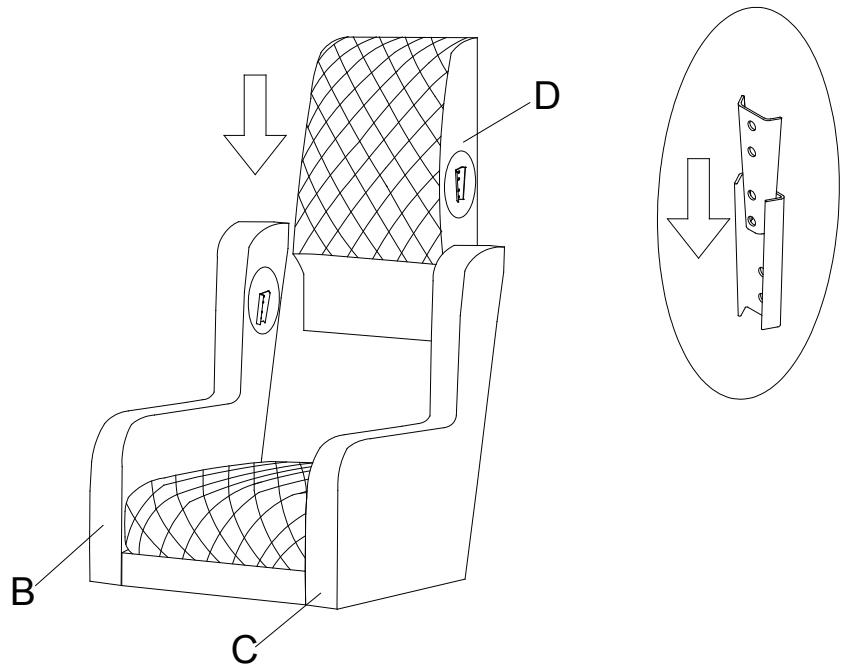

NOTES:

1. CHECK CAREFULLY FOR SMALL PARTS WHICH MAY COME LOOSE DURING SHIPMENT.
2. REMOVE ALL COMPONENTS FROM THE PACK AND PLACE ON A CLEAN, SOFT SURFACE TO ASSEMBLE.
3. UNITS SHOULD BE ASSEMBLED BY TWO OR MORE PEOPLE.
4. DO NOT OVER -TIGHTEN SCREW/ BOLTS UNTIL ASSEMBLY IS COMPLETED.
5. WITH USE, SCREW MAY BE COME LOOSE & MUST BE TIGHTENED PERIODICALLY.

ASSEMBLY INSTRUCTIONS

WINGBACK ACCENT CHAIR

Step 3: Then insert the Bolt (1) and the Flat Washer (2) to the Front leg (E) and the Back Leg (F) and tighten w/ Allen Key(3).

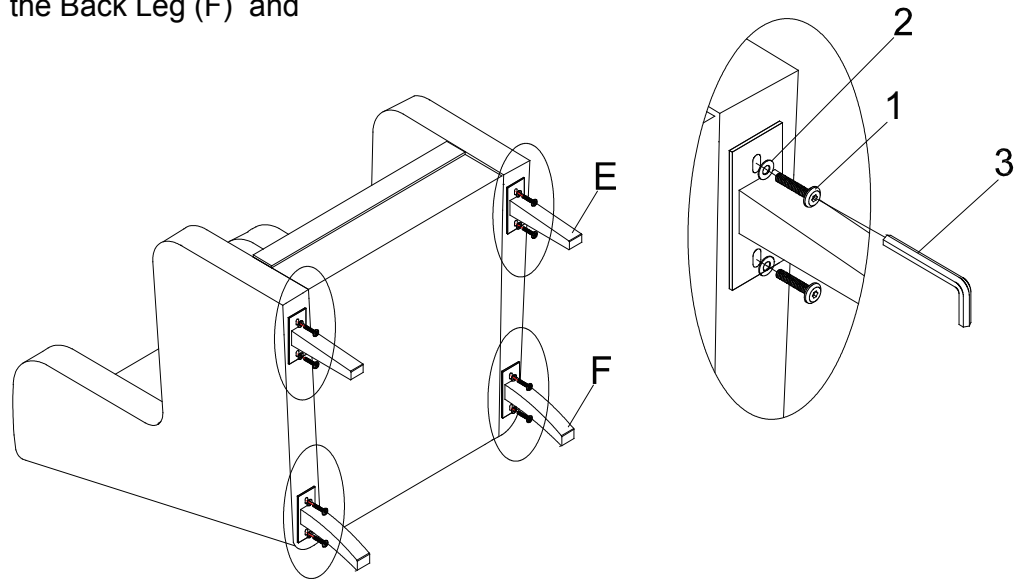

Step 4:

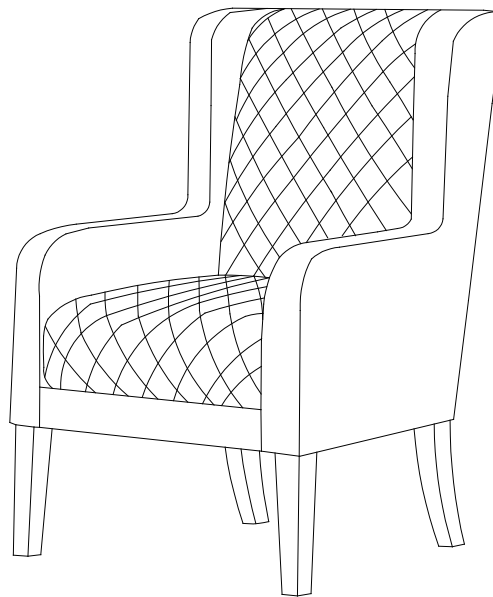

ASSEMBLY COMPLETED

NOTES:

1. CHECK CAREFULLY FOR SMALL PARTS WHICH MAY COME LOOSE DURING SHIPMENT.
2. REMOVE ALL COMPONENTS FROM THE PACK AND PLACE ON A CLEAN, SOFT SURFACE TO ASSEMBLE.
3. UNITS SHOULD BE ASSEMBLED BY TWO OR MORE PEOPLE.
4. DO NOT OVER-TIGHTEN SCREW/ BOLTS UNTIL ASSEMBLY IS COMPLETED.
5. WITH USE, SCREW MAY BECOME LOOSE & MUST BE TIGHTENED PERIODICALLY.