

# Installation Manual

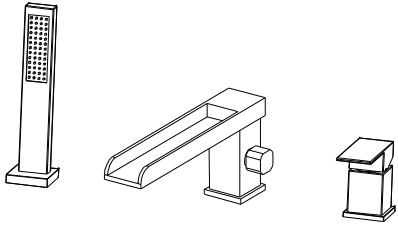

Model:8011

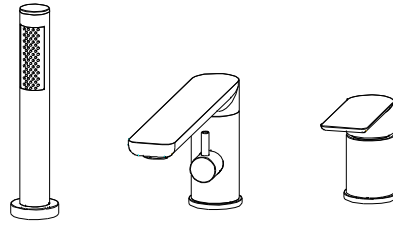

Model:8012

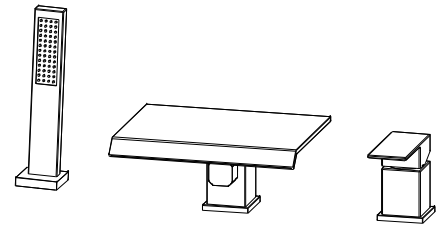

Model:8013

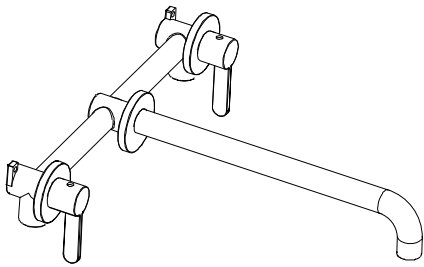

Model:8014

# INDEX

1. cUPC Certification..... P01-02
2. Installation Preparation & Maintenance..... P03
3. 8011..... P04-06
4. 8012..... P07-09
5. 8013..... P10-12
6. 8014..... P13-15

# IAPMO RESEARCH AND TESTING, INC.

5001 E. Philadelphia Street, Ontario, CA 91761 • Phone (909) 472-4100 • Fax (909) 472-4244 • www.iapmort.org



ISO/IEC 17065  
Product Certification Body  
#0202



## CERTIFICATE OF LISTING



IAPMO Research and Testing, Inc. is a product certification body in which its product certification system includes inspection and testing of samples taken from the supplier's stock or from the market or a combination of both to verify compliance to the requirements of applicable codes and standards. This activity is coupled with periodic surveillance of the supplier's factory and/or warehouses as well as the assessment of the supplier's Quality Assurance System. This listing is subject to the conditions set forth in the characteristics below and is not to be construed as any recommendation, assurance or guarantee by IAPMO Research and Testing, Inc. of the product acceptance by Authorities Having Jurisdiction.

*Issued To:*

### JIANGMEN MEITUO SANITARY WARE CO LTD

AREA A, AREA B, 3RD FLOOR, BLOOK 3, NO. 5-3, CHENGNAN 1ST ROAD, CUISHAN LAKE KAIPING, GUANDONG, CHINA

*Product:*

### Plumbing Fixture Fittings

*Products are in compliance with the following code(s):*

**Uniform Plumbing Code (UPC®)  
National Plumbing Code of Canada**

*Products are certified to the following standard(s)*

**ASME A112.18.1-2018/CSA B125.1-18**

File Number: 14172

Effective Date: May 2023

Void After: May 2028\*

  
Chairman, Product Certification Committee



  
Chief Technical Service Officer

\*This certificate is not evidence of current listing. To verify listing status, visit the IAPMO R&T Product Listing Directory at [pld.iapmo.org](http://pld.iapmo.org)

This listing period is based upon the last date of the month indicated on the Effective Date and Void After Date shown above. Any change in material, manufacturing process, marking or design without having first obtained the approval of the Product Certification Committee, or any evidence of non-compliance with applicable codes and standards or of inferior workmanship, may be deemed sufficient cause for revocation of this listing. Production of or reference to this form for advertising purposes may be made only by specific written permission of IAPMO Research and Testing, Inc. Any alteration of this certificate could be grounds for revocation of the listing. This document shall be reproduced in its entirety.

# IAPMO RESEARCH AND TESTING, INC.

## CERTIFICATE OF LISTING



Issued To: JIANGMEN MEITUO SANITARY WARE CO LTD

Effective Date: May 2023

File Number: 14172

Product: Plumbing Fixture Fittings

Void After: May 2028

This certificate is not evidence of current listing. To verify listing status, visit the IAPMO R&T Product Listing Directory at [pld.iapmo.org](http://pld.iapmo.org)

### Identification:

Plumbing supply fittings shall be marked with the manufacturer's recognized name, trademark, or other mark or, in the case of private labeling, the name, trademark or other mark of the customer for whom the fitting was manufactured. The marking shall be accomplished by use of a permanent mark or by placing a permanent label on the product. Markings on plumbing supply fittings shall be visible after installation.

Showerheads and hand-held showers shall be marked with the manufacturer's specified maximum flow rate, in L/min and gpm.

Kitchen, lavatory, and metering faucets shall be marked with the manufacturer's specified maximum flow rate, in L/min and gpm or L/cycle and gpc.

Single-handle and single-control bath and shower mixing valves shall have their temperature control settings identified alphabetically, numerically, or graphically.

High-efficiency commercial pre-rinse spray valves shall be marked with the manufacturer's specified maximum flow rate, in L/min (gpm).

Listed products shall bear the cUPC® certification mark.

Packaging for plumbing supply fittings shall be marked with the manufacturer's name, trademark, or other mark as well as the model number or, in the case of private labeling, the name, trademark, or mark of the customer for whom the fitting was manufactured as well as the model number.

Packaging for showerheads and hand-held showers shall be marked with the manufacturer's specified maximum flow rate and either the manufacturer's specified minimum flow rate or the statement "For use with automatic compensating valves rated at xxx L/min (yyy gpm) or less", where xxx L/min (yyy gpm) is the manufacturer's specified minimum flow rate.

Packaging for kitchen, lavatory, and metering faucets shall be marked with the manufacturer's specified maximum flow rate, in L/min and gpm or L/cycle and gpc.

### Characteristics:

Fittings may include lavatory, sink, bath & shower, lawn and sediment faucets. Plumbing fixture fittings to be installed in accordance with the manufacturer's instructions and the requirements of the latest edition of the Uniform Plumbing Code and National Plumbing Code of Canada.

Products listed on this certificate have been tested by an IAPMO R&T recognized laboratory. This recognition has been granted based upon the laboratory's compliance to the applicable requirements of ISO/IEC 17025.

## 1. Installation Precautions

1. When you open the product packing, please check the product and accessories at first. If there is any discrepancy, please contact the company or our distributor immediately.
2. The hot and cold water supply pipe of the faucet must be properly connected. When facing the front of the faucet, the hot water supply is on the left and cold water supply is on the right. Incorrect connection will cause permanent damage to the cartridge.
3. If the accessories to be changed without affecting the use, we will not make a prior notice.
4. The impurities in the water supply pipe must be cleared before installation to avoid blockage.
5. The water pressure of the faucet is 20 PSI -100 PSI (including cold water and hot water pressure) Applicable water temperature range: 40°F-170°F.

## 2. Preparation before installation

1. Please read the installation manual carefully before installation.
2. Installation work must be performed by a professional installer.
3. Installation tool.



## 3. Product reparation

If the cartridge is worn out which cause leakage, please turn off the water source. Remove the handle, panel, and decorative cover in sequence, remove the gland with a wrench, then take out the cartridge and copper sleeve.

Repair or replace the new cartridge, then install it again in sequence.

## 4. Clearance and Maintenance

In order to keep the faucet appearance smooth and good performance, please follow the below steps to clean and maintain the faucet.

1. Clean with water and dry with a soft cotton cloth.
2. Use a mild liquid and a colorless glass cleaner to remove surface dirt and scale, also you can use the cleaner without grinding function.
3. Do not use detergents, polishing tools, abrasive cloth, paper towels or scrapers to clean the faucet.
4. Do not use acid cleaners, insoluble granular detergents, soaps, etc to clean the faucet.

# Model: 8011

## Installation Instruction 1/3

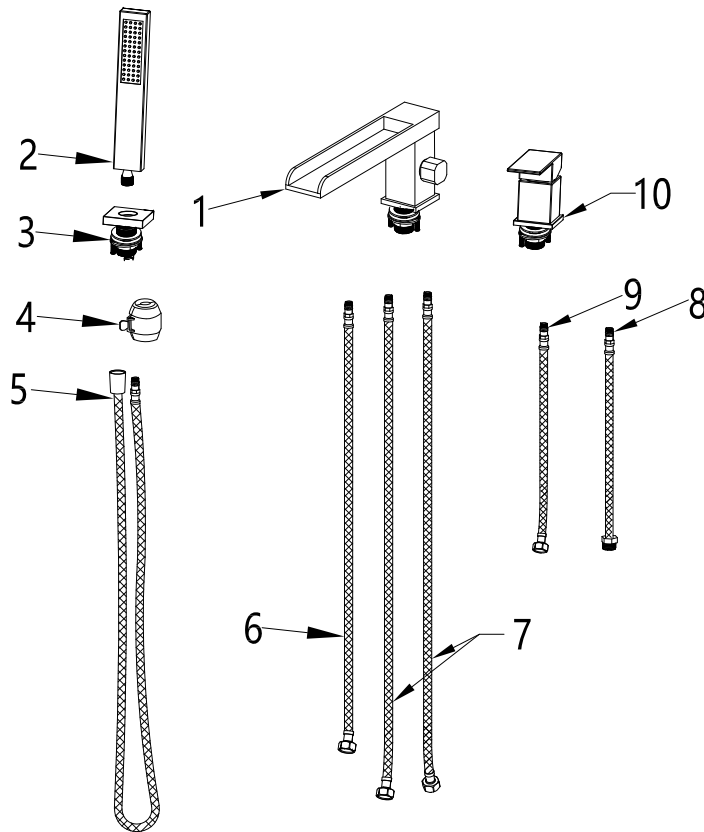

No	Description	QTY
1	Main body	1
2	Handheld shower	1
3	Shower seat	1
4	Gravity ball	1
5	Sprinkler hose	1
6	Mixing pipe	1
7	Cold and hot water inlet pipe	2
8	Male thread inlet pipe	1
9	Internal thread outlet pipe	1
10	On/off handle	1

## Installation Instruction

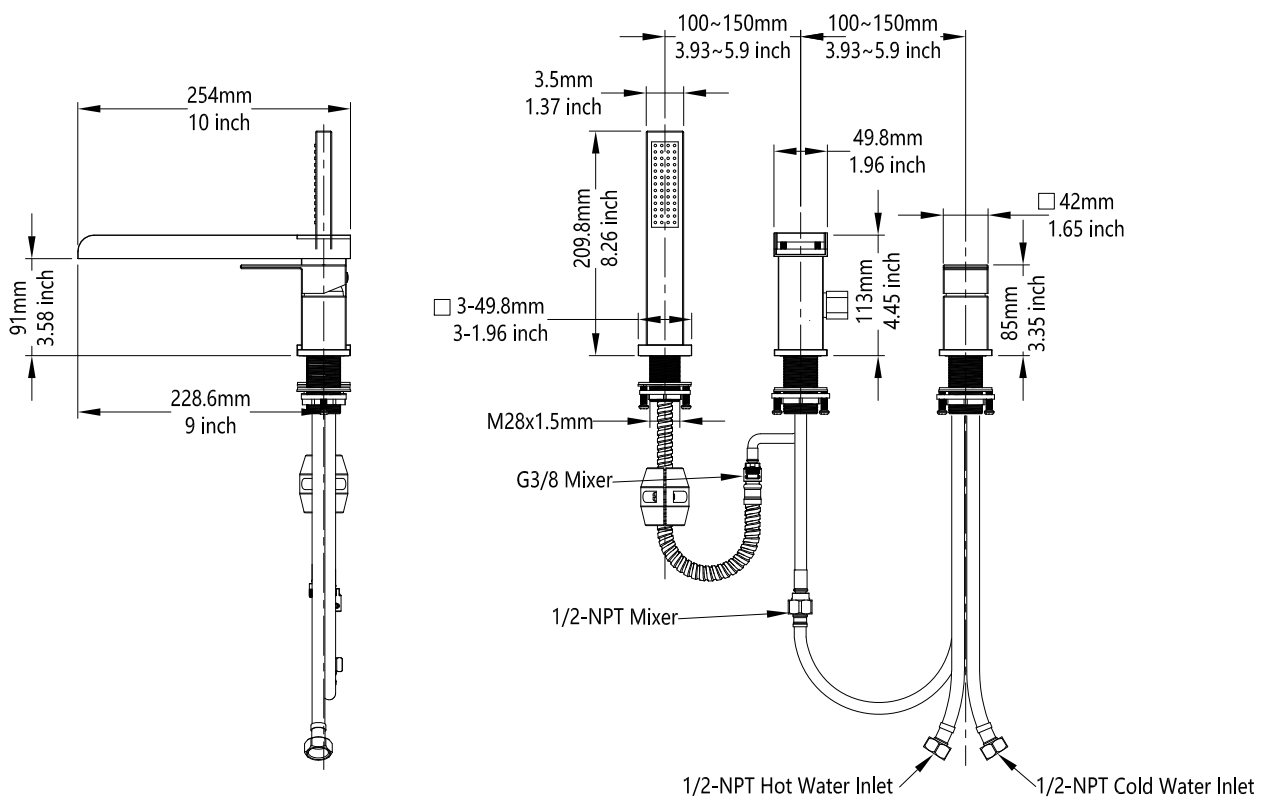

# Model: 8011

## Installation Instruction 2/3

Installation steps.

1. Wash the pre-buried pipe before installing the faucet.

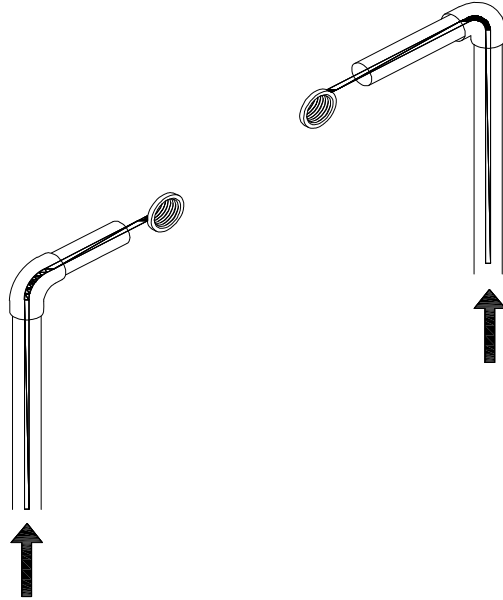

2. Before installation, please make sure there are 2 hole of  $\Phi 33 \sim \Phi 35 \text{mm}$  and 1 hole of  $\Phi 29 \sim \Phi 31 \text{mm}$  with center distance the diameter 200~300mm on the basin sink. And disassemble the fixing parts of faucet body and handle.

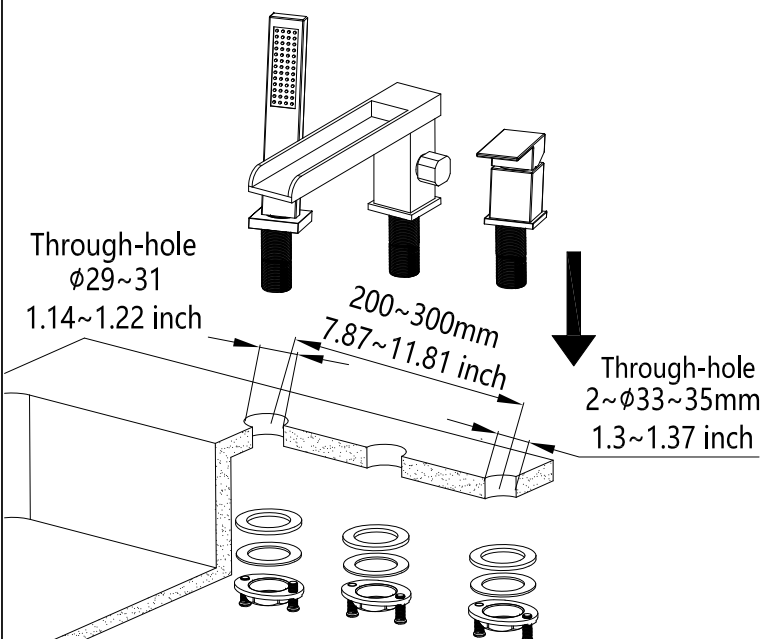

3. Put the main body in the hole of basin sink, and put the gasket on the bottom of decoration cup. Then screw the fixing parts on the faucet according to the steps. And use the spanner to screw the body and the nut, and use the phillips screwdriver to screw.

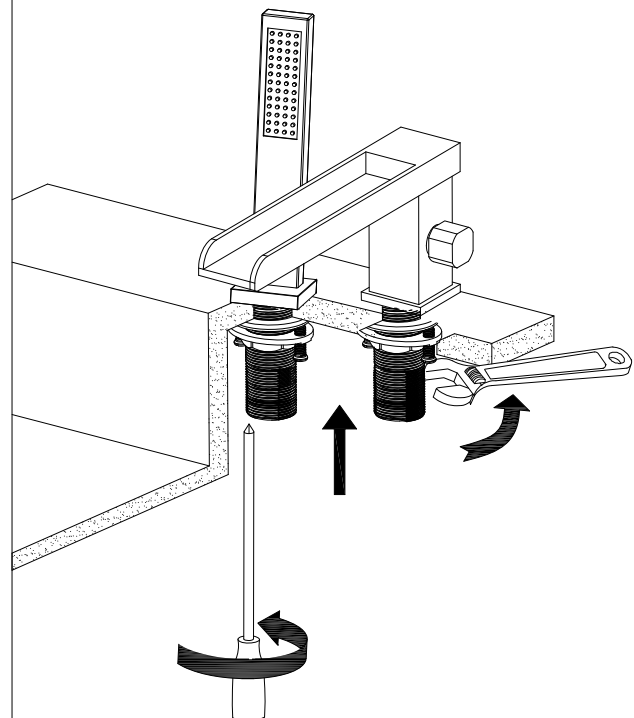

# Model: 8011 Installation Instruction 3/3

4. Connect the pipe.

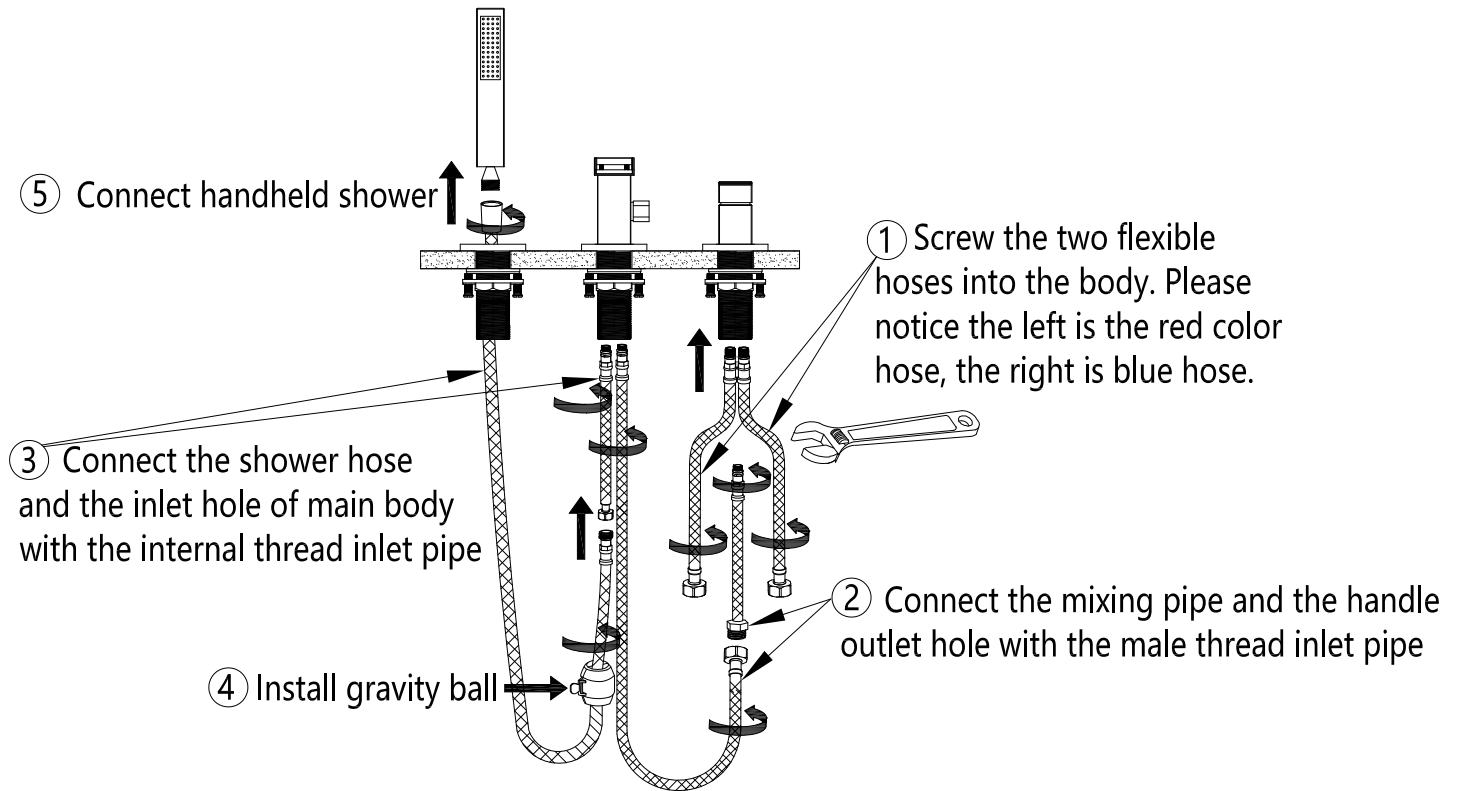

5. Connect two inlet hoses on the faucet to angle valve. Connect red inlet hose to hot water supply, and blue inlet hose to cold water supply.

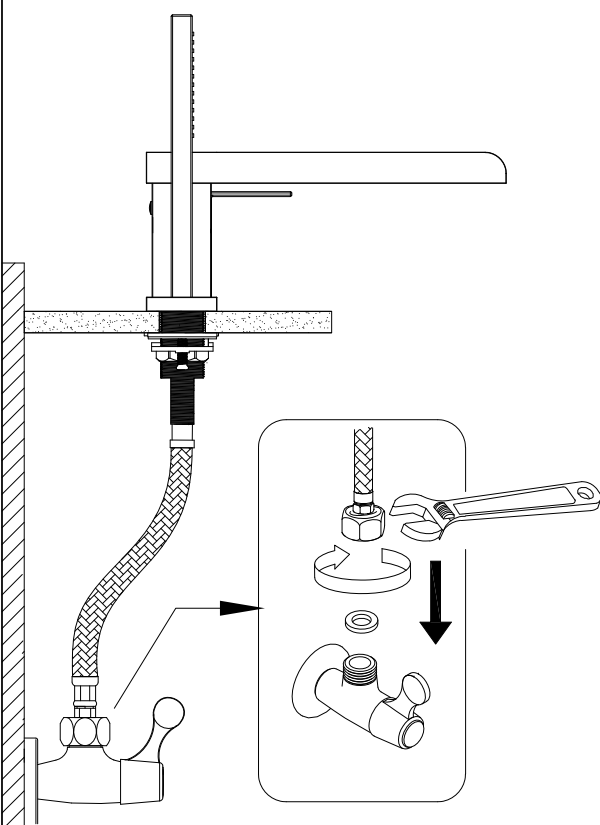

6. Open the water supply. Check for leaks in the connections.

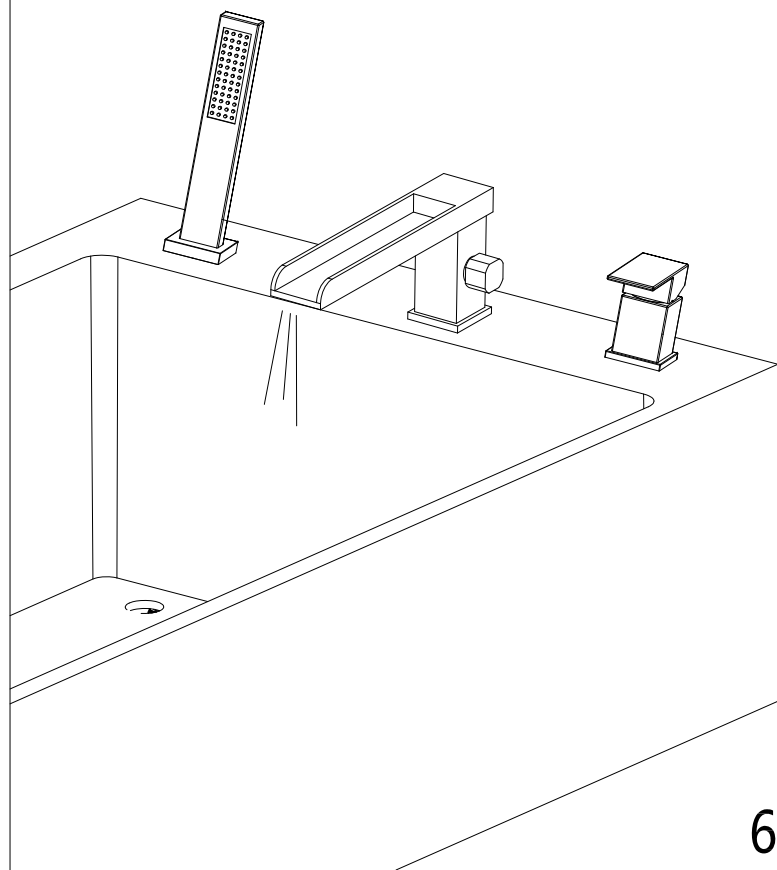

# Model: 8012

## Installation Instruction 1/3

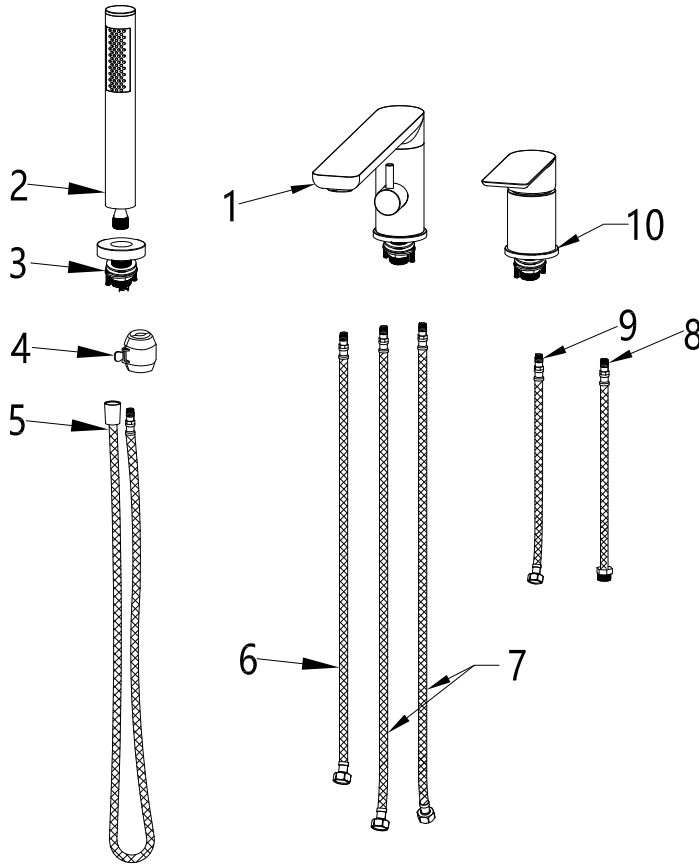

No	Description	QTY
1	Main body	1
2	Handheld shower	1
3	Shower seat	1
4	Gravity ball	1
5	Sprinkler hose	1
6	Mixing pipe	1
7	Cold and hot water inlet pipe	2
8	Male thread inlet pipe	1
9	Internal thread outlet pipe	1
10	On/off handle	1

## Installation Instruction

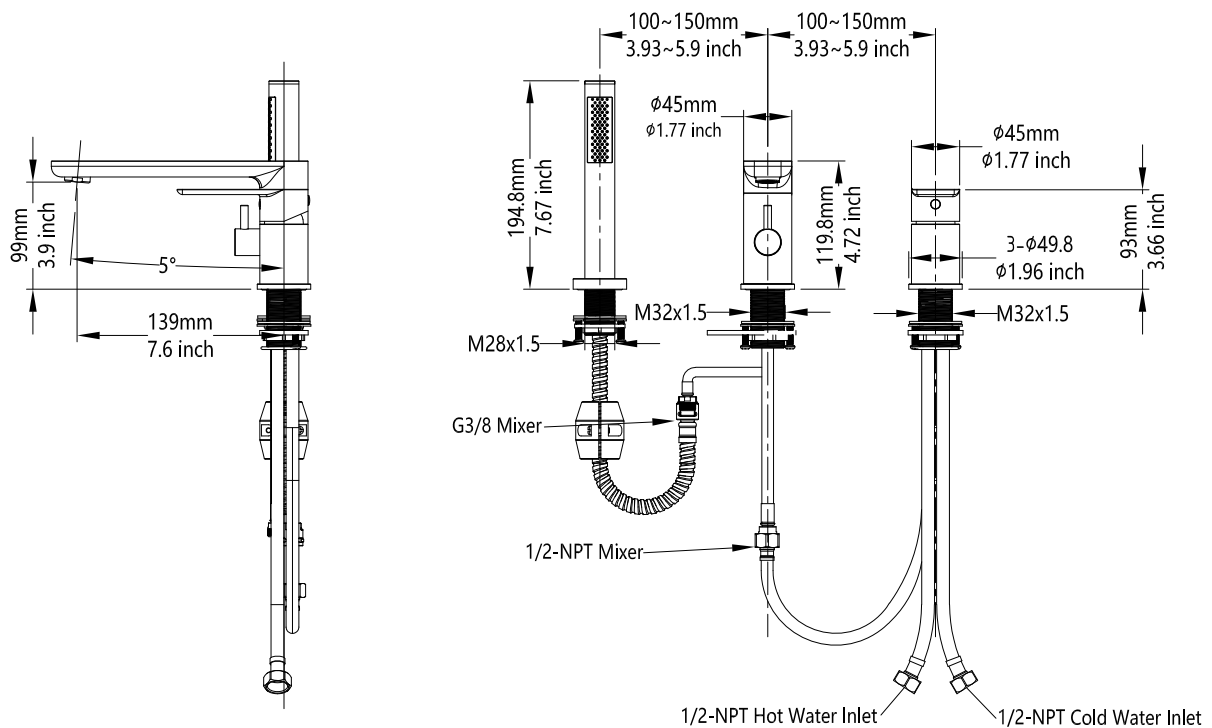

# Model: 8012

## Installation Instruction 2/3

Installation steps.

1. Wash the pre-buried pipe before installing the faucet.

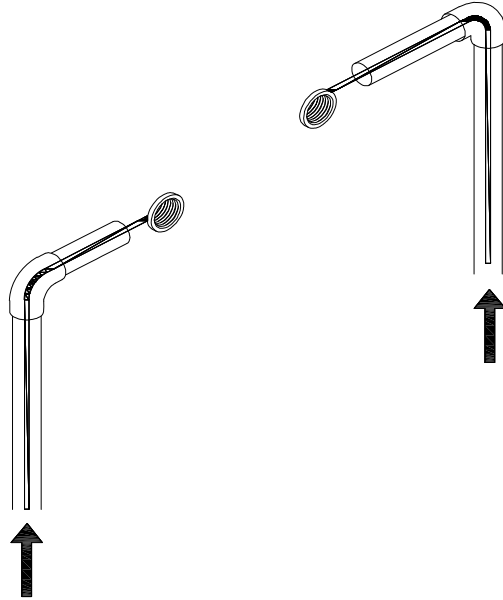

2. Before installation, please make sure there are 2 hole of  $\Phi 33\sim\Phi 35\text{mm}$  and 1 hole of  $\Phi 29\sim\Phi 31\text{mm}$  with center distance the diameter 200~300mm on the basin sink. And disassemble the fixing parts of faucet body and handle.

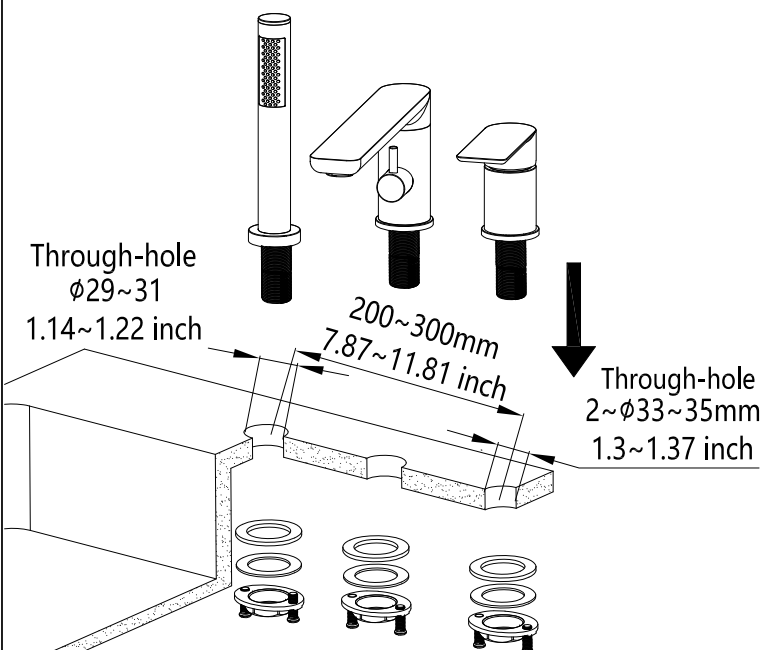

3. Put the main body in the hole of basin sink, and put the gasket on the bottom of decoration cup. Then screw the fixing parts on the faucet according to the steps. And use the spanner to screw the body and the nut, and use the phillips screwdriver to screw.

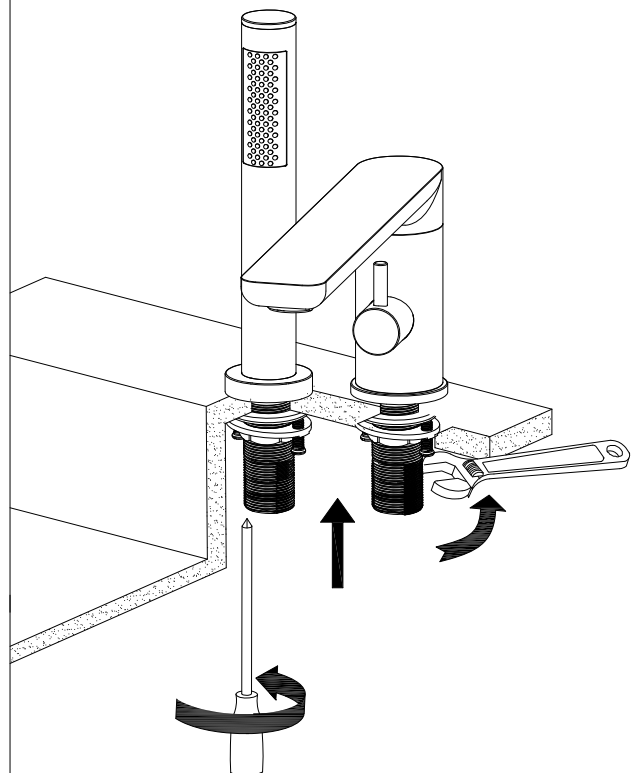

# Model: 8012 Installation Instruction 3/3

4. Connect the pipe.

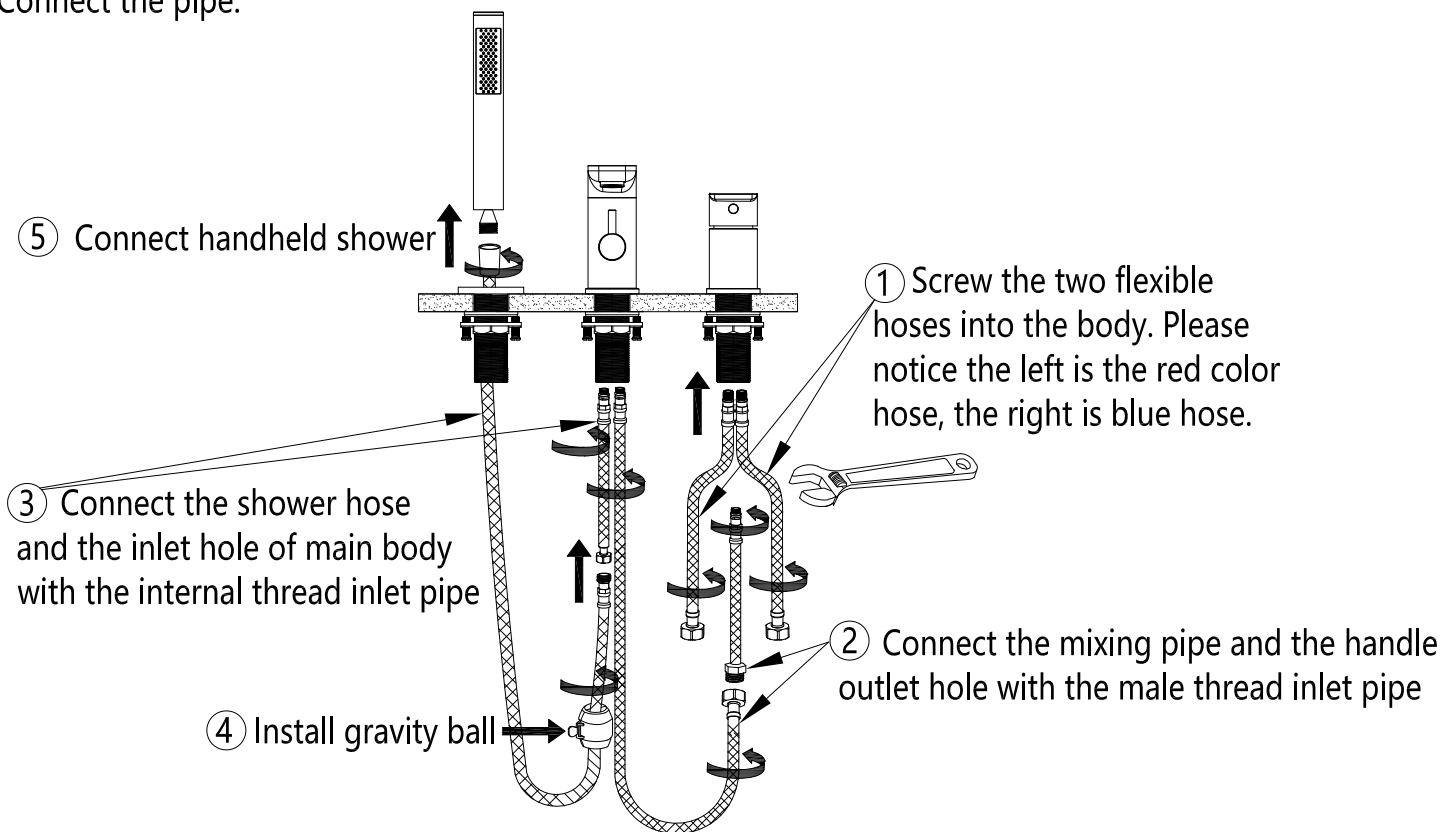

5. Connect two inlet hoses on the faucet to angle valve. Connect red inlet hose to hot water supply, and blue inlet hose to cold water supply.

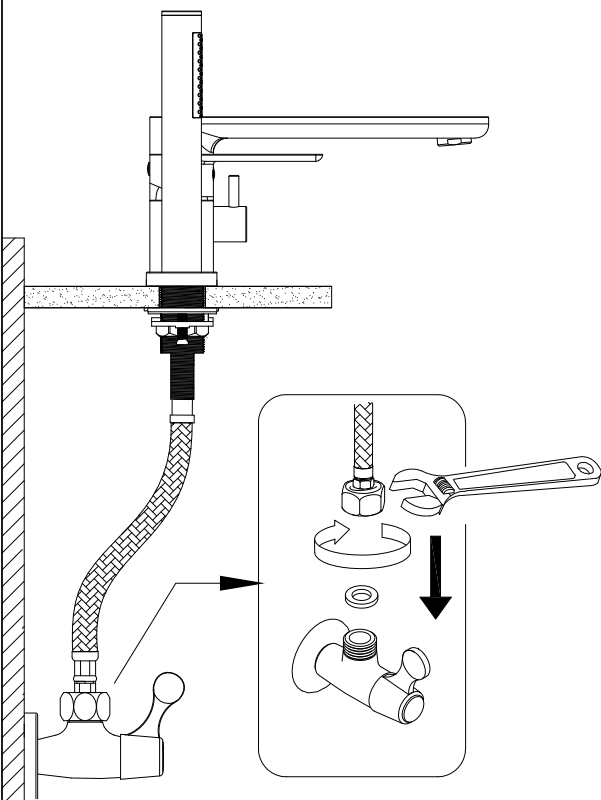

6. Open the water supply. Check for leaks in the connections.

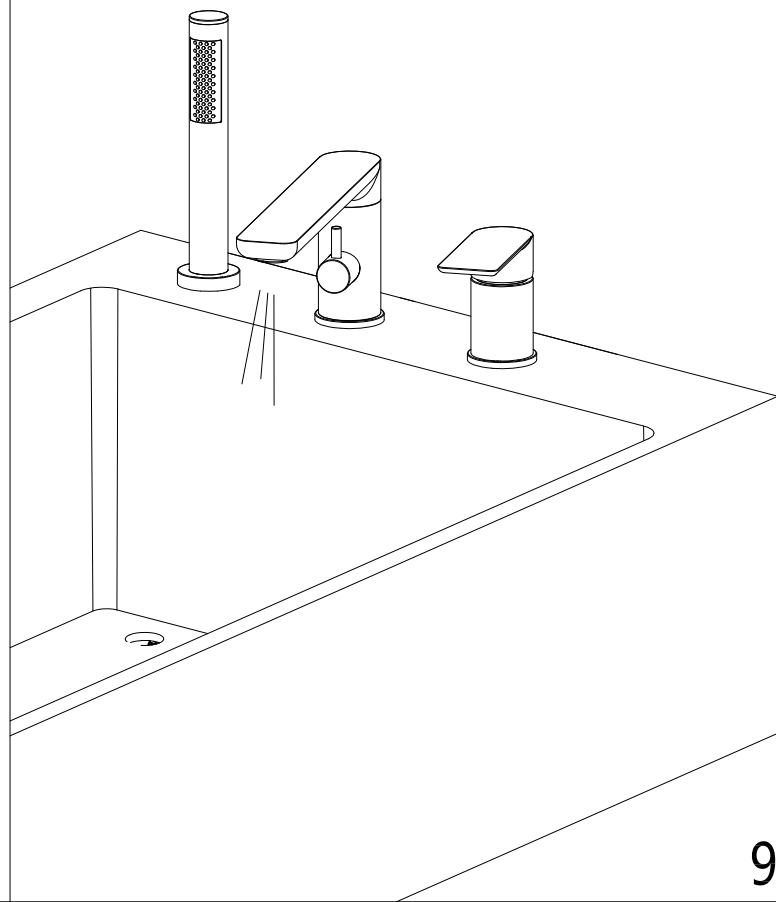

# Model: 8013

## Installation Instruction 1/3

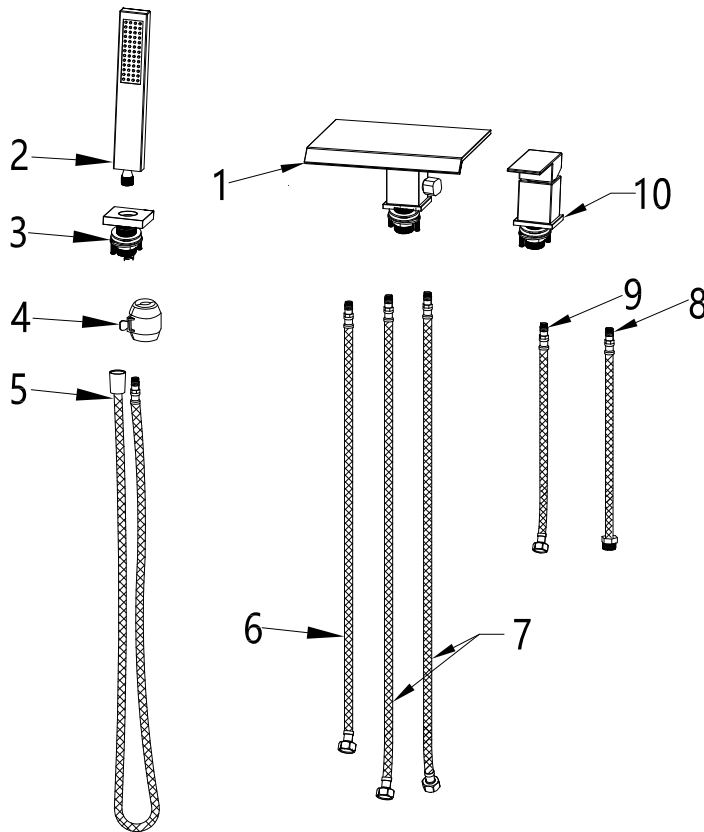

No	Description	QTY
1	Main body	1
2	Handheld shower	1
3	Shower seat	1
4	Gravity ball	1
5	Sprinkler hose	1
6	Mixing pipe	1
7	Cold and hot water inlet pipe	2
8	Male thread inlet pipe	1
9	Internal thread outlet pipe	1
10	On/off handle	1

### Installation Instruction

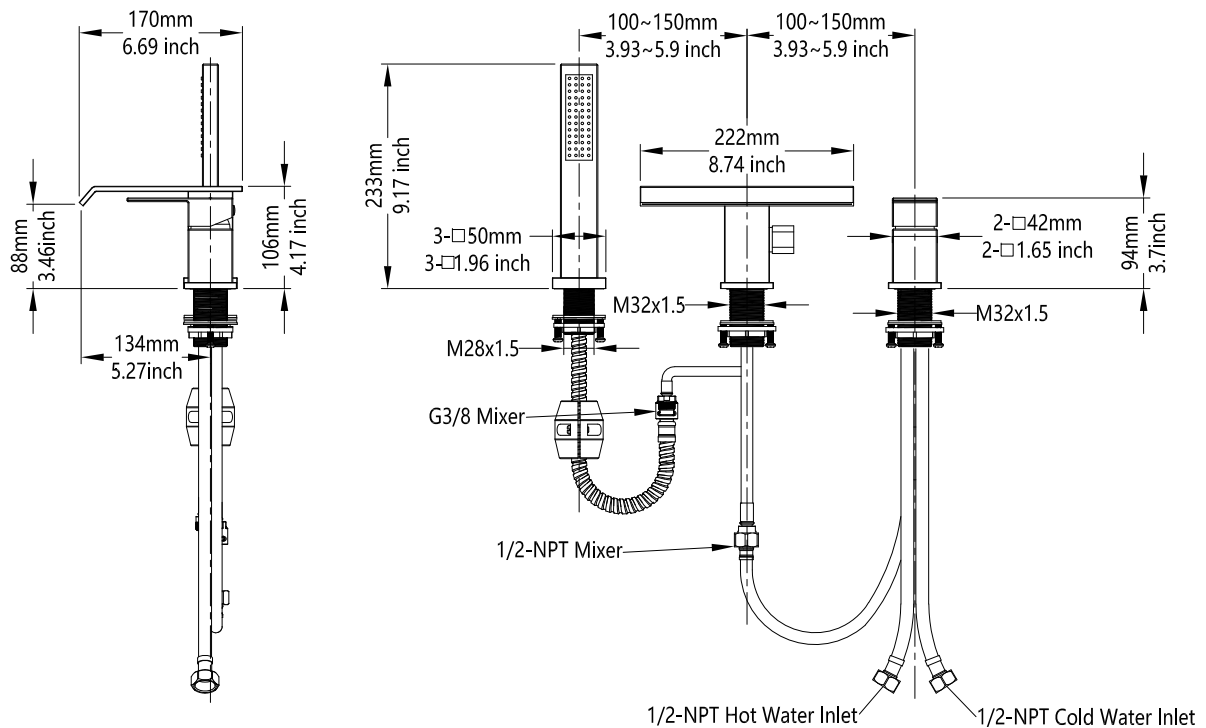

# Model: 8013

## Installation Instruction 2/3

Installation steps.

1. Wash the pre-buried pipe before installing the faucet.

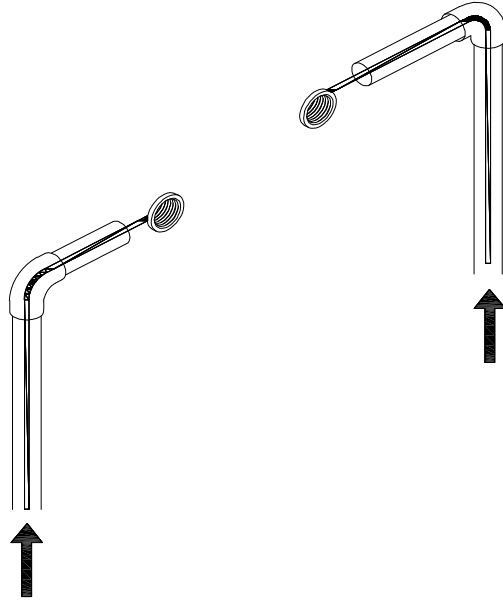

2. Before installation, please make sure there are 2 hole of  $\Phi 33\sim\Phi 35\text{mm}$  and 1 hole of  $\Phi 29\sim\Phi 31\text{mm}$  with center distance the diameter 200~300mm on the basin sink. And disassemble the fixing parts of faucet body and handle.

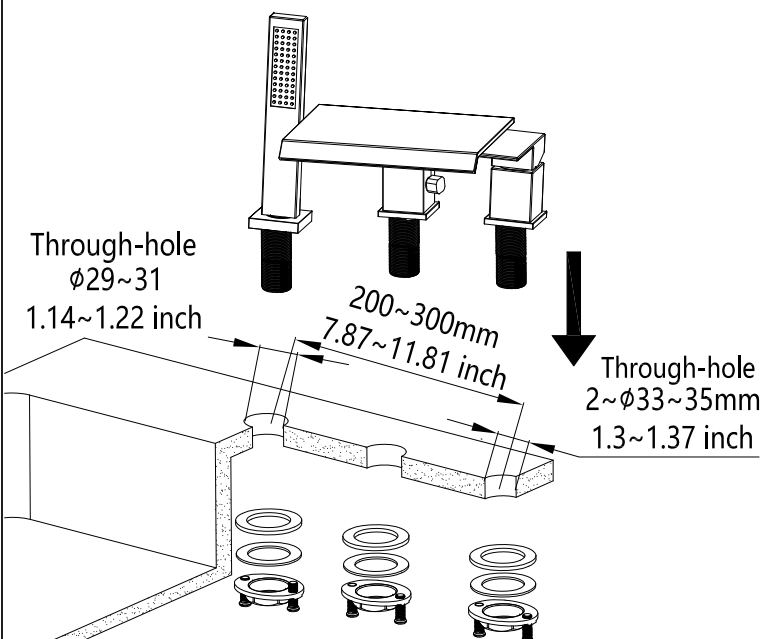

3. Put the main body in the hole of basin sink, and put the gasket on the bottom of decoration cup. Then screw the fixing parts on the faucet according to the steps. And use the spanner to screw the body and the nut, and use the phillips screwdriver to screw.

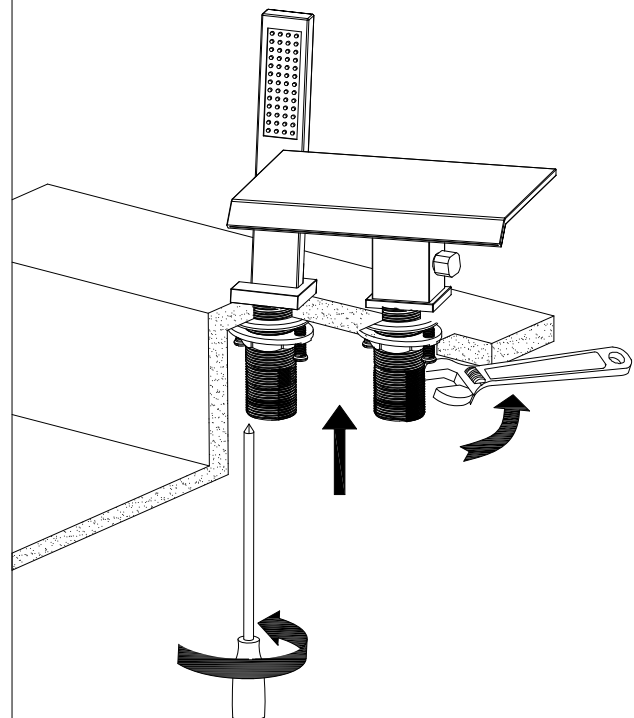

# Model: 8013 Installation Instruction 3/3

4. Connect the pipe.

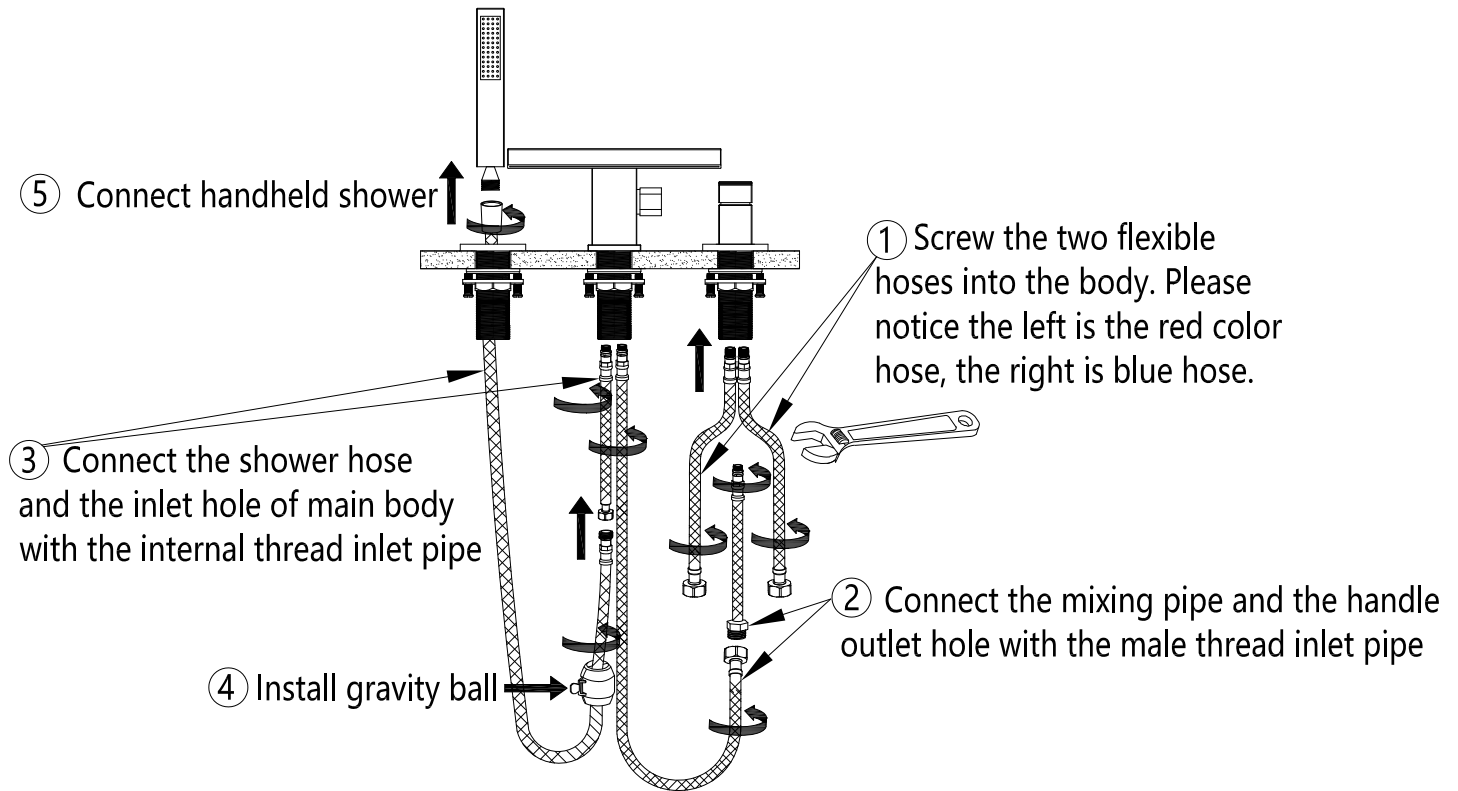

5. Connect two inlet hoses on the faucet to angle valve. Connect red inlet hose to hot water supply, and blue inlet hose to cold water supply.

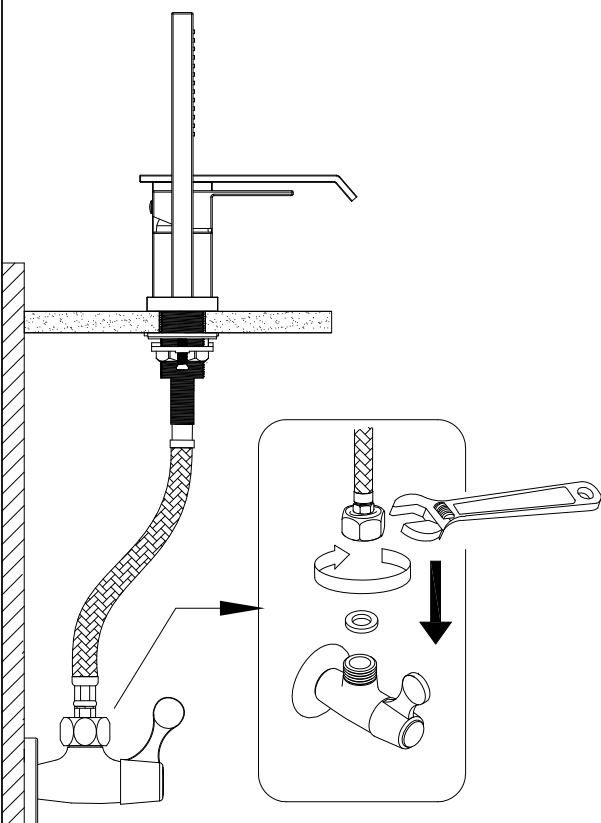

6. Open the water supply. Check for leaks in the connections.

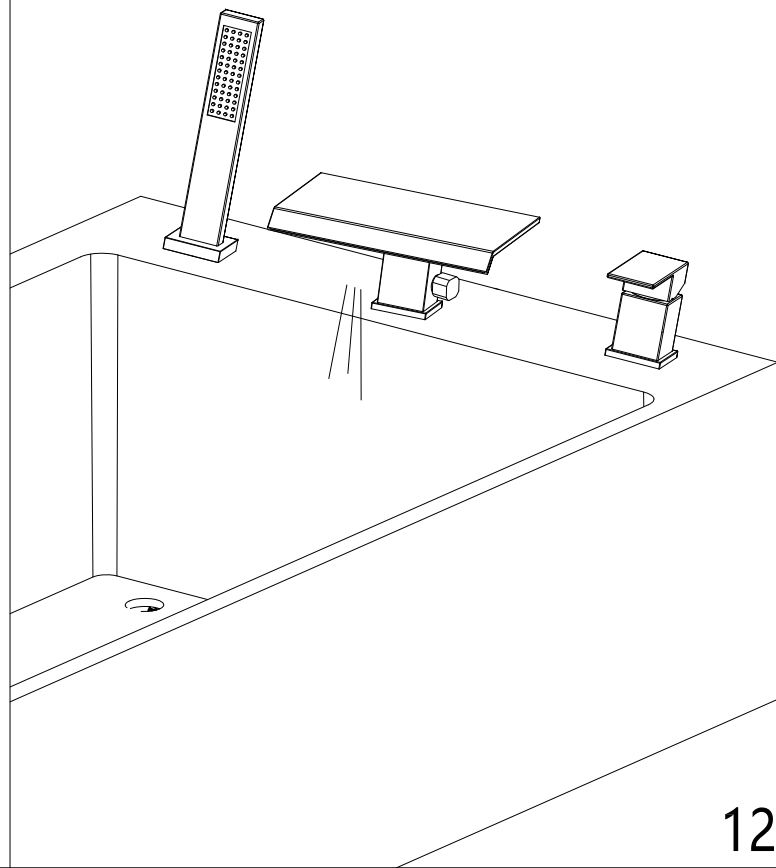

# Model: 8014 Installation Instruction 1/3

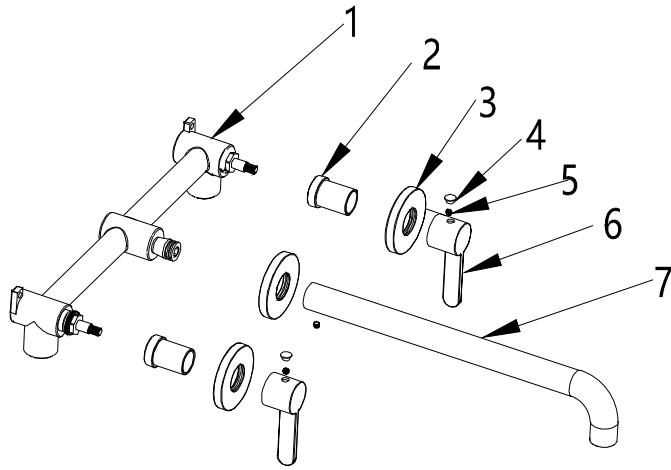

No	Description	QTY
1	Main Body	1
2	Copper Sleeve	2
3	Decorative Cover	3
4	Color Button	2
5	Fixing Screw	3
6	Handle	2
7	Water Outlet Pipe	1

## Installation Instruction

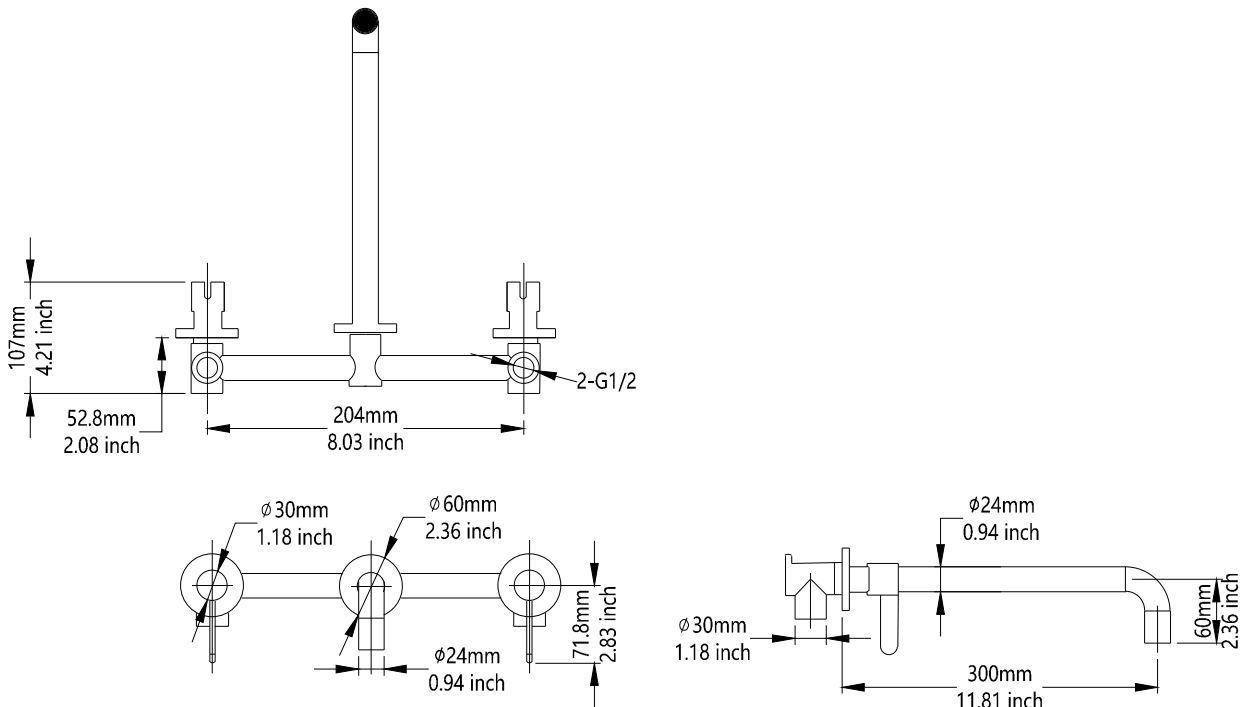

# Model: 8014

## Installation Instruction 2/3

### Installation steps

1. The sundries at the connection must be removed before installation to avoid blockage or water leakage
2. Correctly connect the tap water inlet as shown in the figure (as shown in the figure)
3. Three D35 holes are large for tile block, and the center distance between holes is 102
4. The maximum temperature of hot water shall not be higher than 80 ° C.

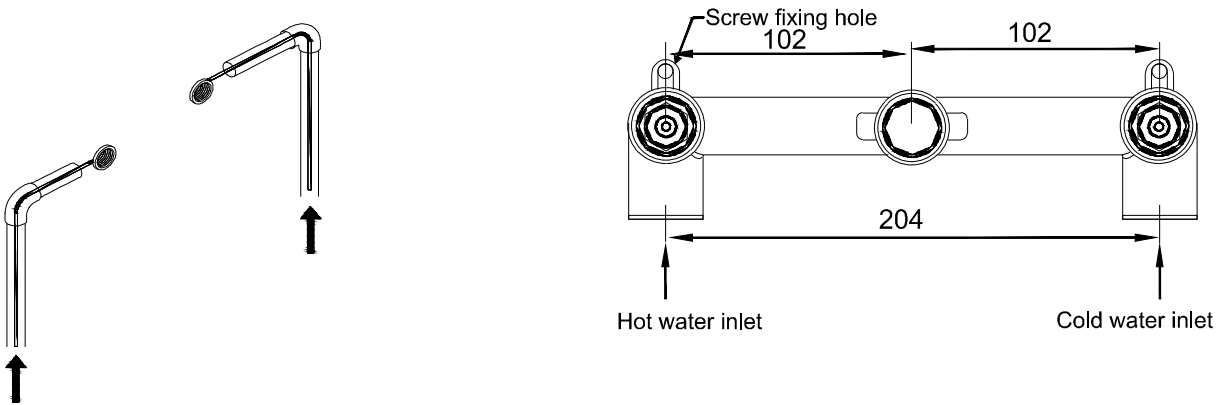

As shown in the drawing, the wall surface (including the ceramic tile surface) at the location where the wall is buried should be flush with or slightly higher than the main body plane (for reference, it can be slightly adjusted)

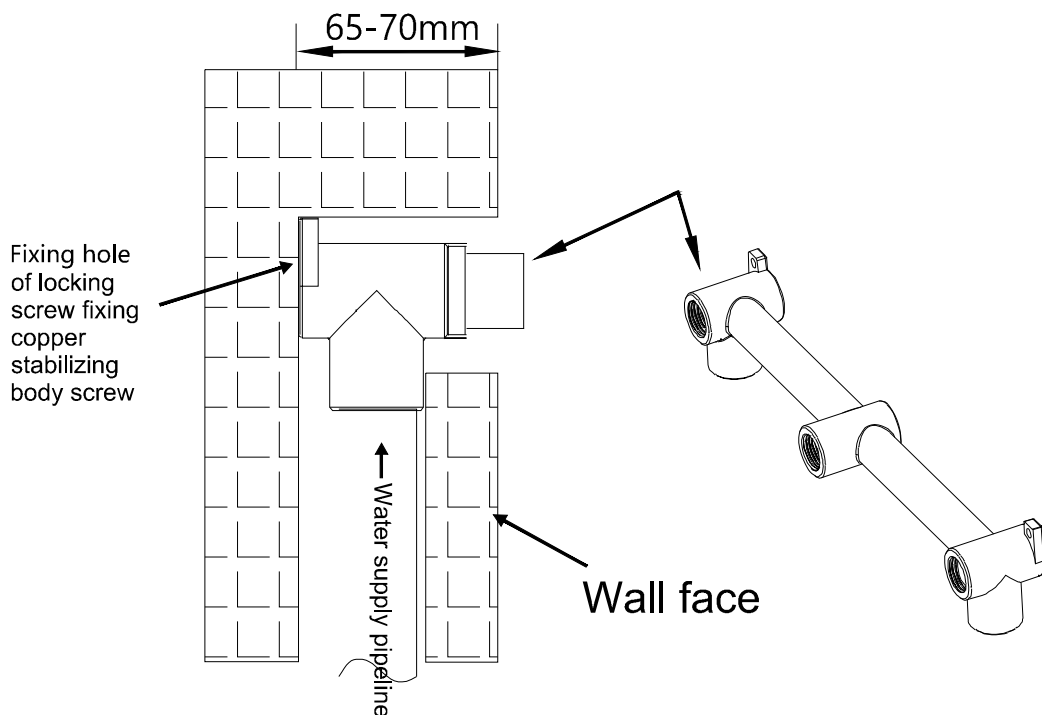

# Model: 8014 Installation Instruction 3/3

1

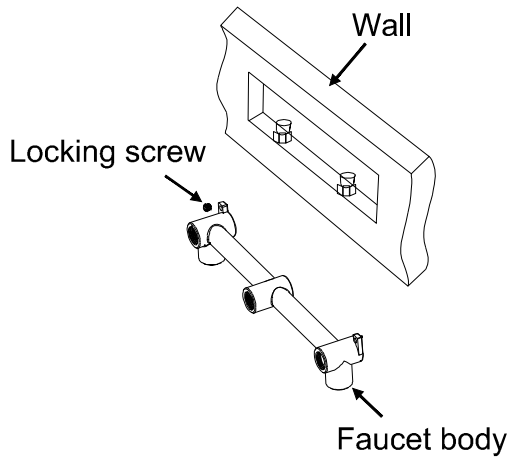

2

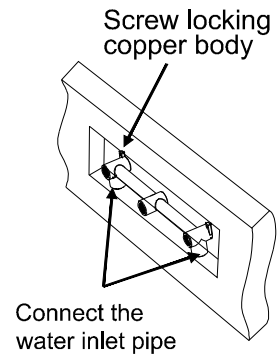

3

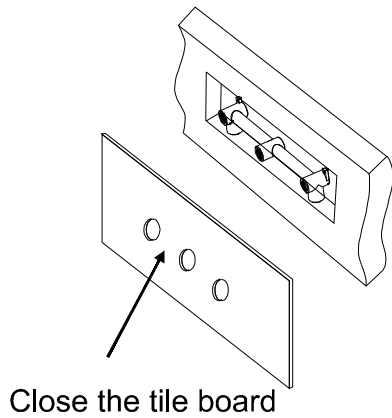

4

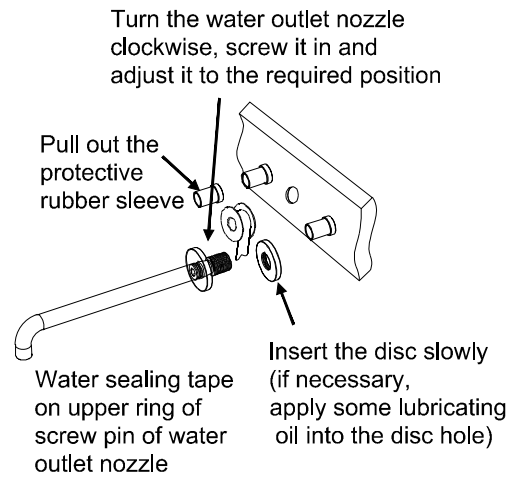

5

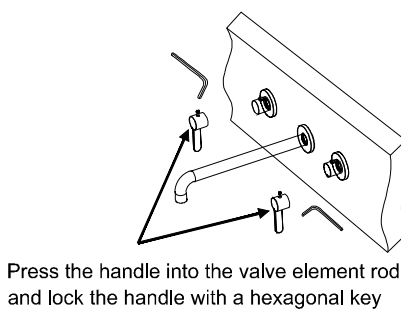

6

