

# ASSEMBLY INSTRUCTIONS

DESCRIPTION: KING BED

Caution: Please read instructions thoroughly before unpacking assembly parts. Sharp, exposed staple tips can cause injury, therefore, for your protection, please remove any exposed staple used in packing.

1. We recommend that you should assemble this product with the assistance of another person; this will make assembly easier, and will help to eliminate damage to the product or injury to persons during assembly.
2. Be sure to check all packing materials carefully for small parts that may have come lose inside the carton during shipment.
3. Please do not over tighten screws or bolts until the assembly is completed.
4. Please put all parts on a non-abrasive floor before assembly, and follow the assembly steps to assemble your newly purchased product correctly and efficiently.

## TOOLS REQUIRED (Not provided)

PHILLIPS SCREWDRIVER

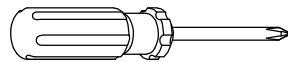

## HARDWARE LIST :

No.	Description	Sketch	Size	Quality
A	Bolt		$\text{Ø}\frac{5}{16}$ " x 60mm	8PCS
B	Bolt		$\text{Ø}\frac{5}{16}$ " x 45mm	8PCS
C	Bolt		$\text{Ø}\frac{1}{4}$ " x 20mm	8PCS
D	Bolt		$\text{Ø}\frac{1}{4}$ " x 40mm	16PCS
E	Spring Washer		$\text{Ø}\frac{5}{16}$ "	16PCS
F	Flat Washer		$\text{Ø}\frac{5}{16}$ "	16PCS
G	Spring Washer		$\text{Ø}\frac{1}{4}$ "	24PCS
H	Flat Washer		$\text{Ø}\frac{1}{4}$ "	24PCS
J	Allen Key		M4	1PC
K	Screw		M4x 35mm	28PCS
L	Metal Hook Left			2PCS
M	Metal Hook Right			2PCS

## PART LIST :

(1)	Headboard		1PC
(2)	Headboard Leg- Left		1PC
(3)	Headboard Leg- Right		1PC
(4)	Footboard		1PC
(5)	Side Rail ( Cap)		2PCS
(6)	Side Rail ( Outer Panel)		2PCS
(7)	Side Rail ( Inner Panel)		2PCS
(8)	Side Rail ( Bottom Panel)		2PCS
(9)	Slats roll		2Set
(10)	Center Rail		4PCS
(11)	Center Support Leg		8PCS
(12)	Mains Power Lead (3m)		1PC
(13)	TV Lift Remote		1PC

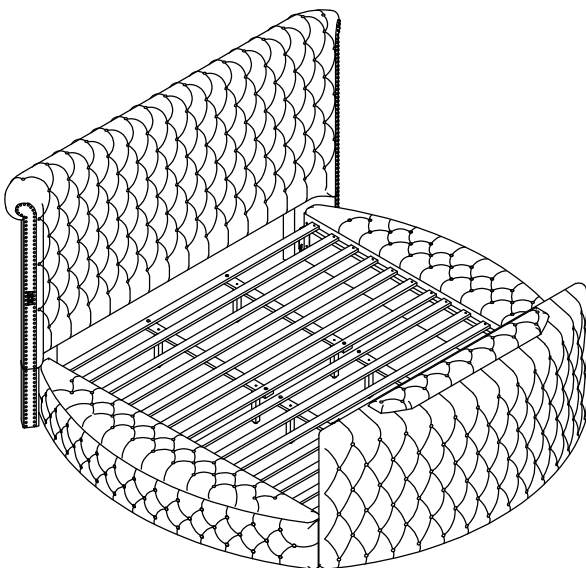



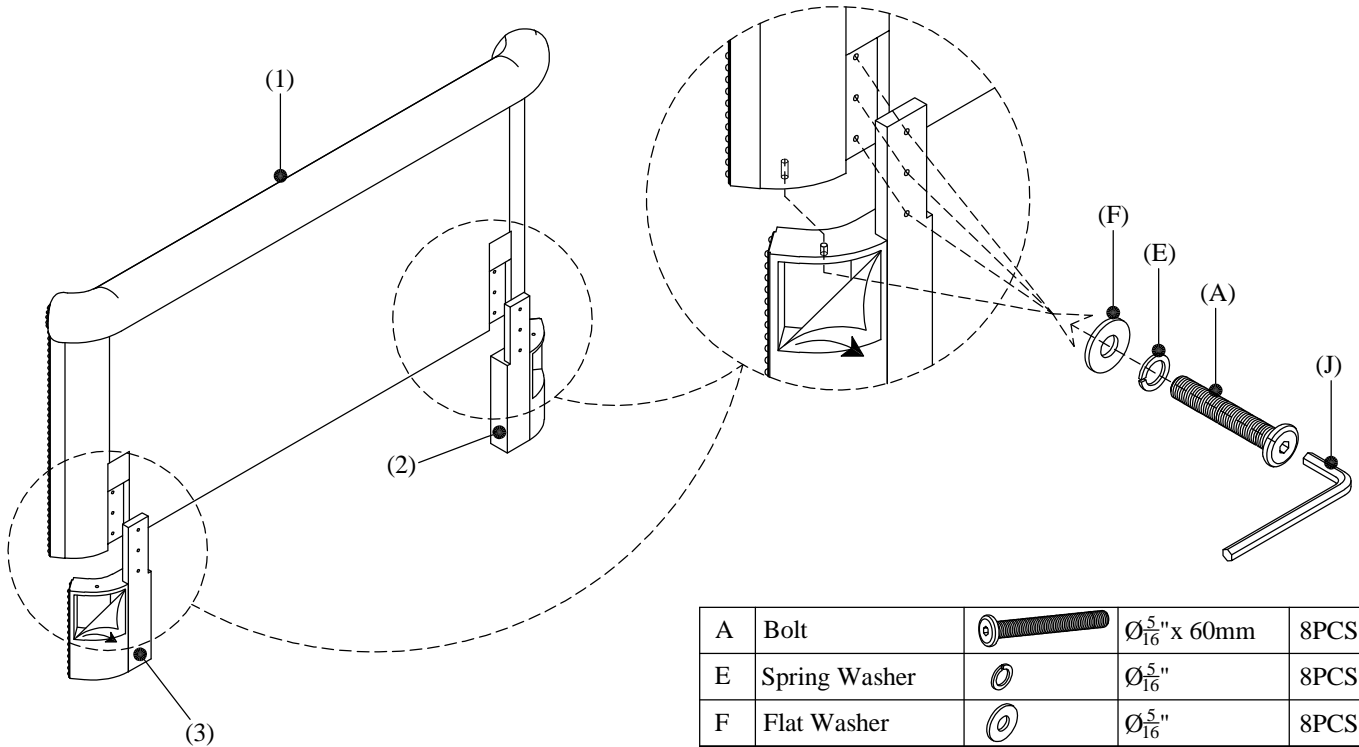

# ASSEMBLY INSTRUCTIONS

DESCRIPTION: KING BED





Step 1: Assemble Headboard (1) with Headboard Leg (2)&(3).

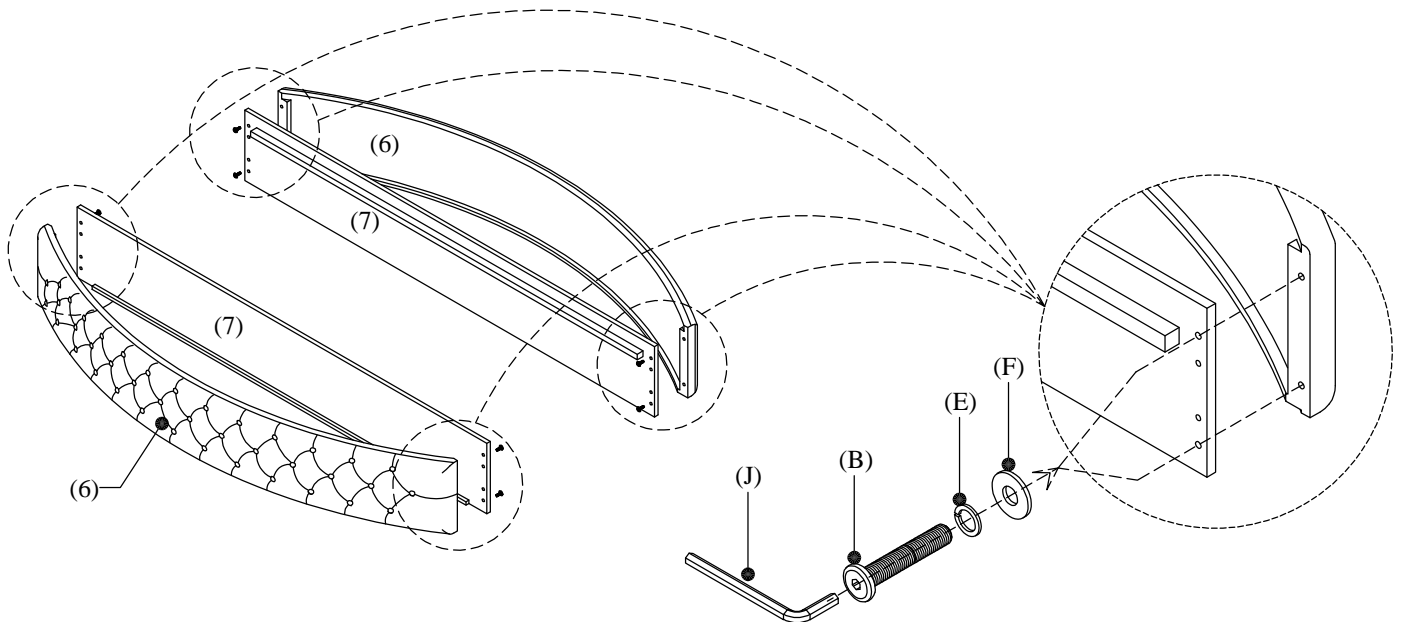

A	Bolt		$\text{Ø}\frac{5}{16}'' \times 60\text{mm}$	8PCS
E	Spring Washer		$\text{Ø}\frac{5}{16}''$	8PCS
F	Flat Washer		$\text{Ø}\frac{5}{16}''$	8PCS
J	Allen Key		M4	1PC

Step 2: Assemble Side Rail (Outer Panel) (6) with Side Rail (Inner Panel) (7).







B	Bolt		$\text{Ø}\frac{5}{16}'' \times 45\text{mm}$	8PCS
E	Spring Washer		$\text{Ø}\frac{5}{16}''$	8PCS
F	Flat Washer		$\text{Ø}\frac{5}{16}''$	8PCS
J	Allen Key		M4	1PC

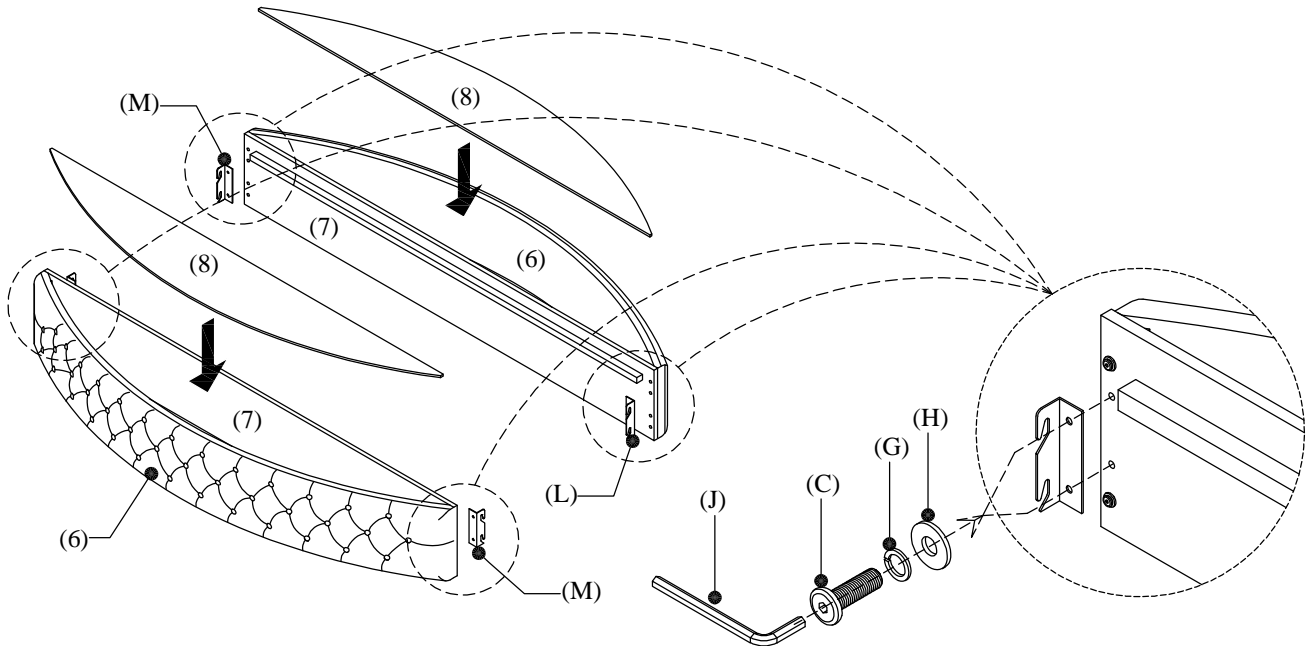

# ASSEMBLY INSTRUCTIONS

DESCRIPTION: KING BED

Step 3: Assemble Side rail with Metal Hook Left (L) & Metal Hook Right (M). Place Side rail (Bottom Panel) (8) inside the of Side rail storage.



C	Bolt		$\text{Ø}\frac{1}{4}'' \times 20\text{mm}$	8PCS
G	Spring Washer		$\text{Ø}\frac{1}{4}''$	8PCS
H	Flat Washer		$\text{Ø}\frac{1}{4}''$	8PCS
J	Allen Key		M4x 4"L	1PC

L	Metal Hook Left			2PCS
M	Metal Hook Right			2PCS

Step 4: Place Side rail( Cap) (5) on top of the side rail storage.

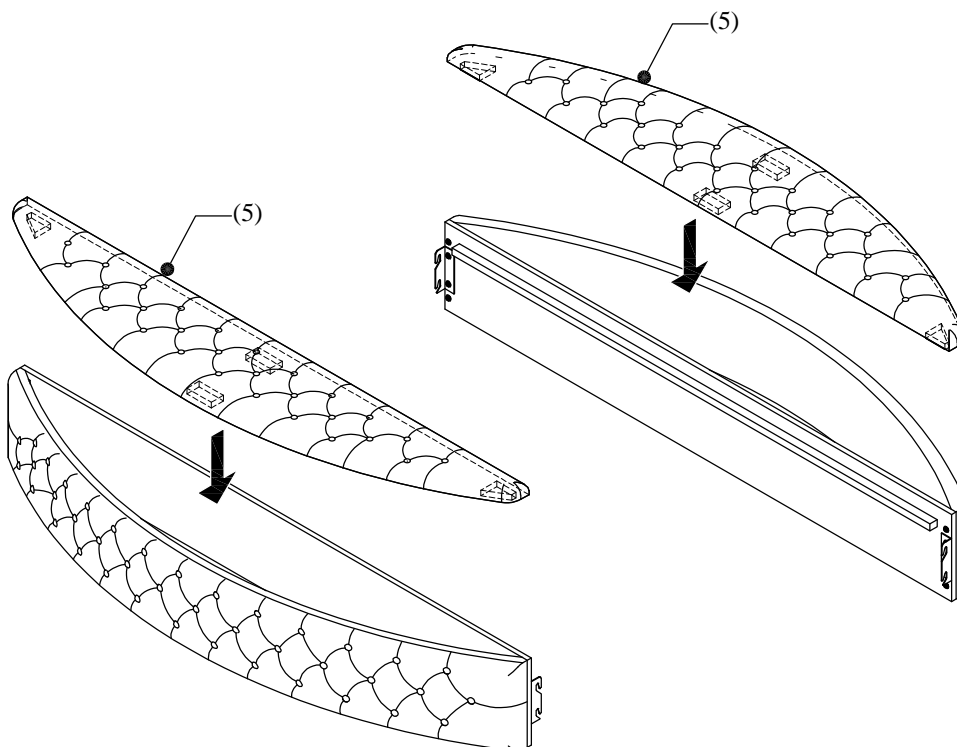



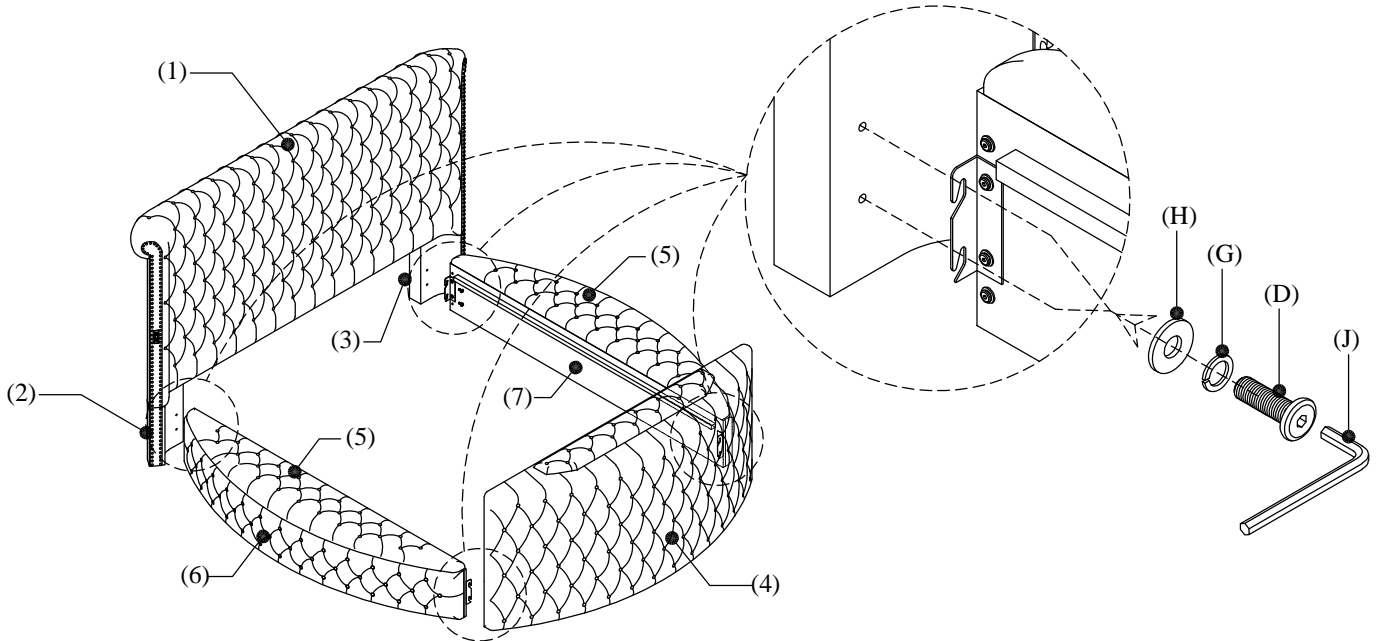

# ASSEMBLY INSTRUCTIONS

DESCRIPTION: KING BED

Step 5: Assemble Side Rail with Headboard leg & Footboard (4).



D	Bolt		$\text{Ø}\frac{1}{4}" \times 40\text{mm}$	8PCS
G	Spring Washer		$\text{Ø}\frac{1}{4}"$	8PCS
H	Flat Washer		$\text{Ø}\frac{1}{4}"$	8PCS
J	Allen Key		M4x 4"L	1PC

Step 6: Connect Main Power Lead (12) to your wall socket - for safety, this must be an earthed supply

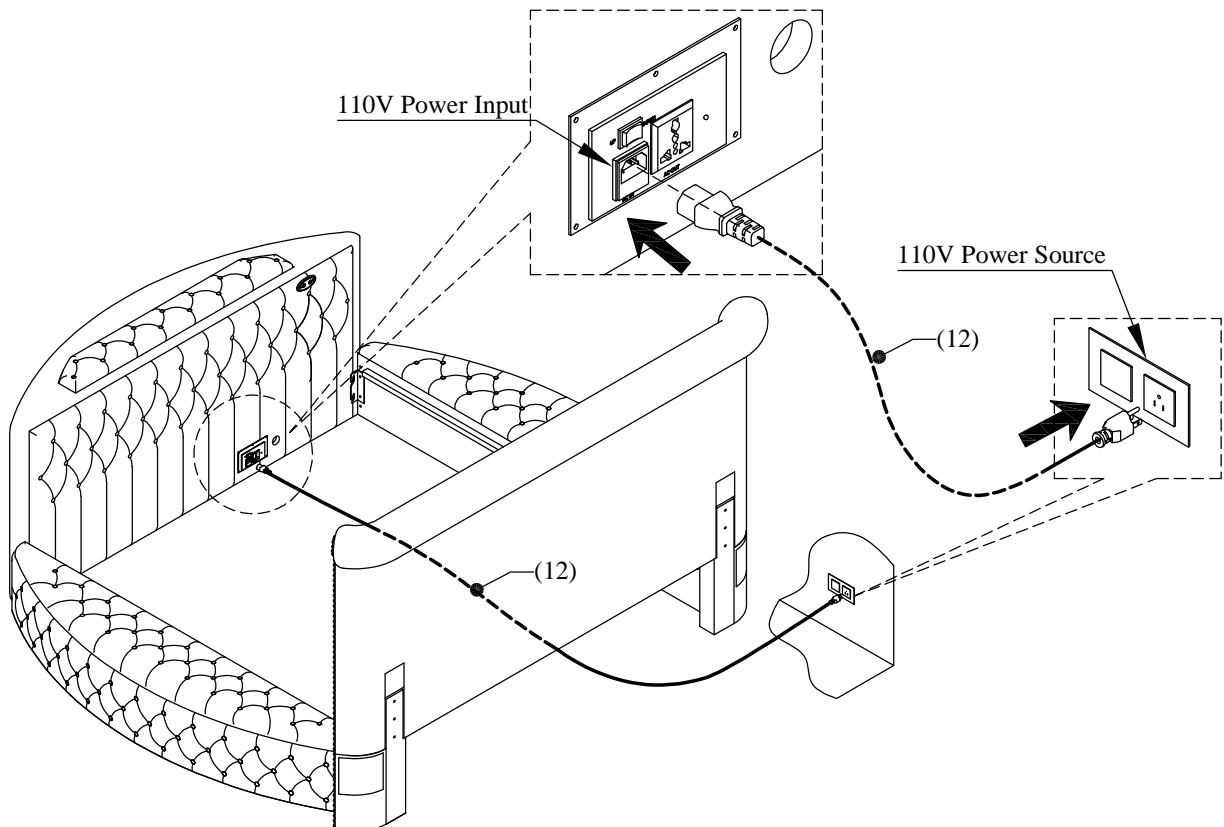

# ASSEMBLY INSTRUCTIONS

DESCRIPTION: KING BED

Step 7: Press the "UP" button to raise the TV lift frame.

There are two different ways to raise up the TV lift frame:

1. Use the manual control which as show (A) press on button



2. Use remote control press on button

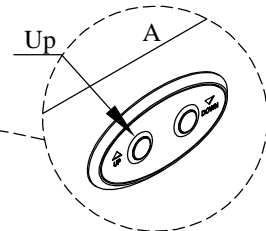

Use the manual control

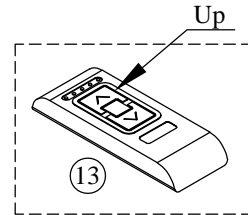

Use remote control

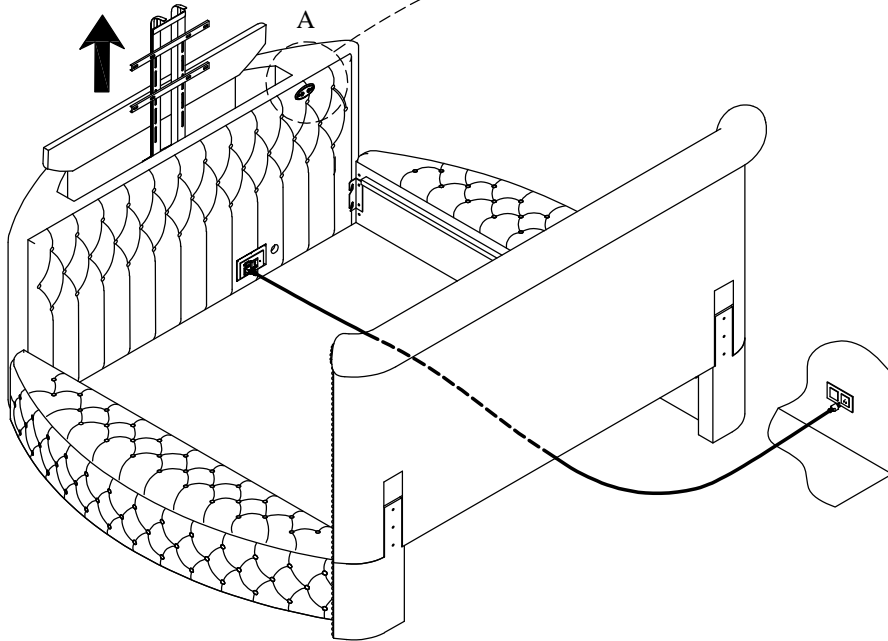

Step 8: Assemble your TV on TV lift frame in footboard.

TV INSTALLATION KIT (supplied with your TV )

a	Screw-Washer set (M8/M6/M4)		x4
b	Allen Key (5mm/4mm/2.5mm)		x1

Warning: TV maximum size  
50" Length x 28" Width x 4" Thickness

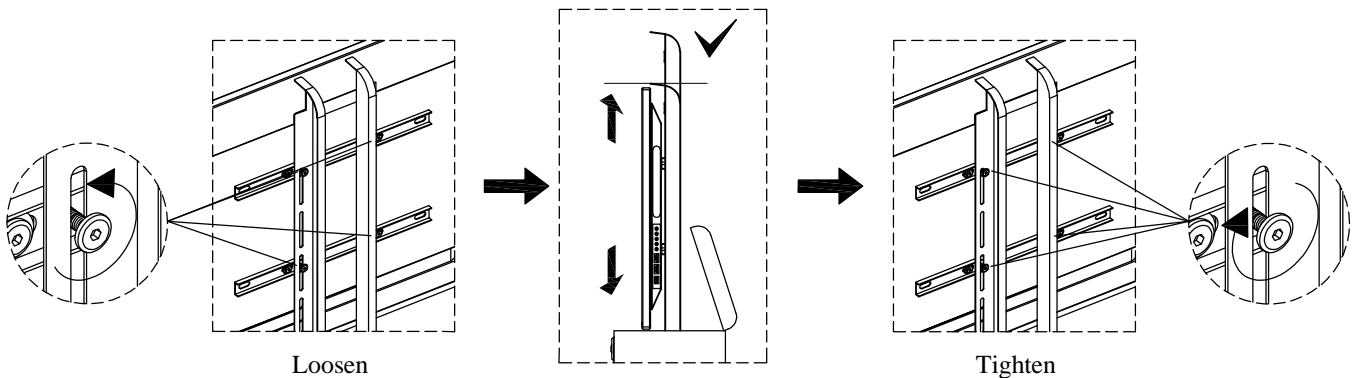
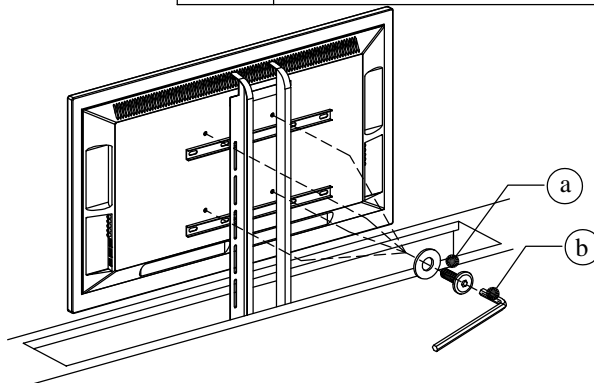
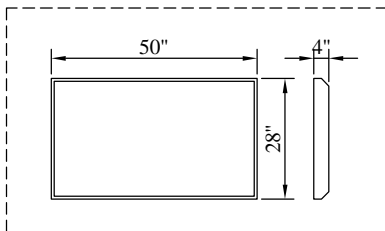

# ASSEMBLY INSTRUCTIONS

DESCRIPTION: KING BED

Step 9: Press the "DOWN" button to lower the TV lift frame.

There are two different ways to lower down the TV lift frame:

1. Use the manual control which as show (A) press on button



2. Use remote control press on button

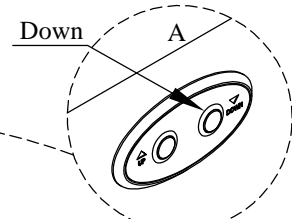

Use the manual control

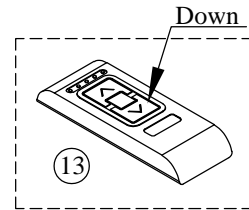

Use remote control

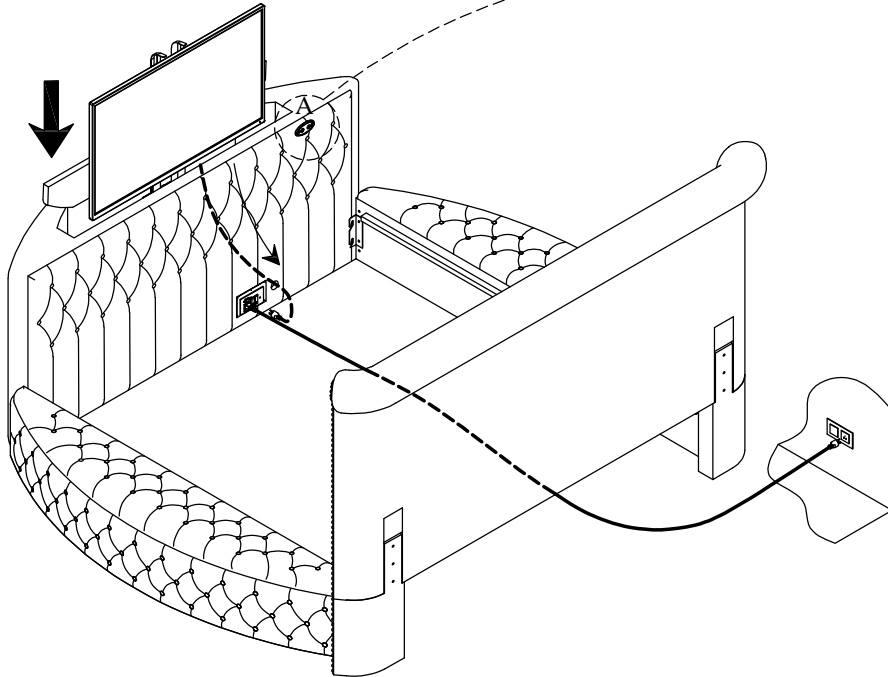

Step 10: Connect your TV electric with the output 110V socket.

Plug in the wire of USB with USB adaptor, then connect with power.

Connect your TV electric from this output 110V

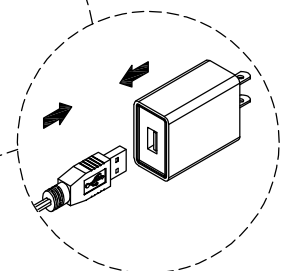
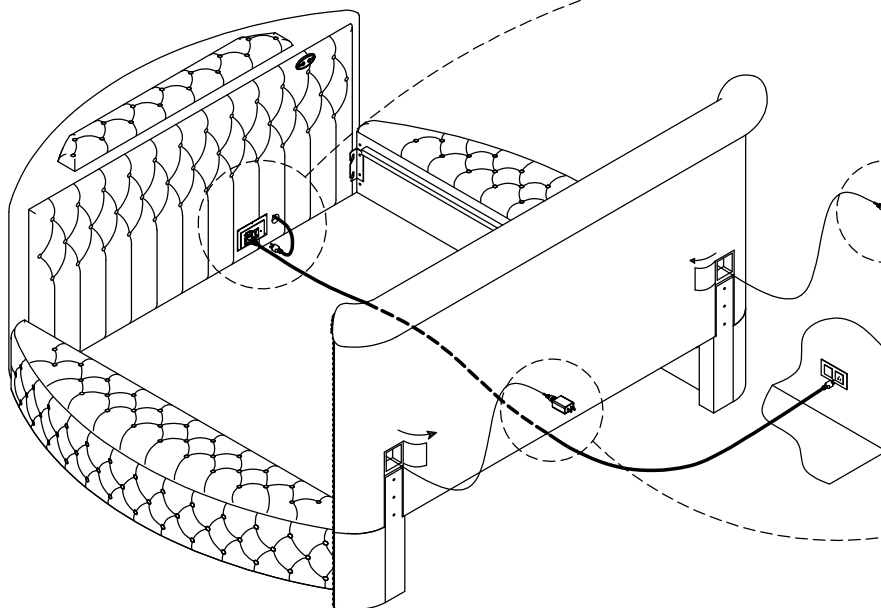
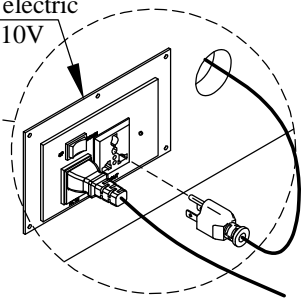



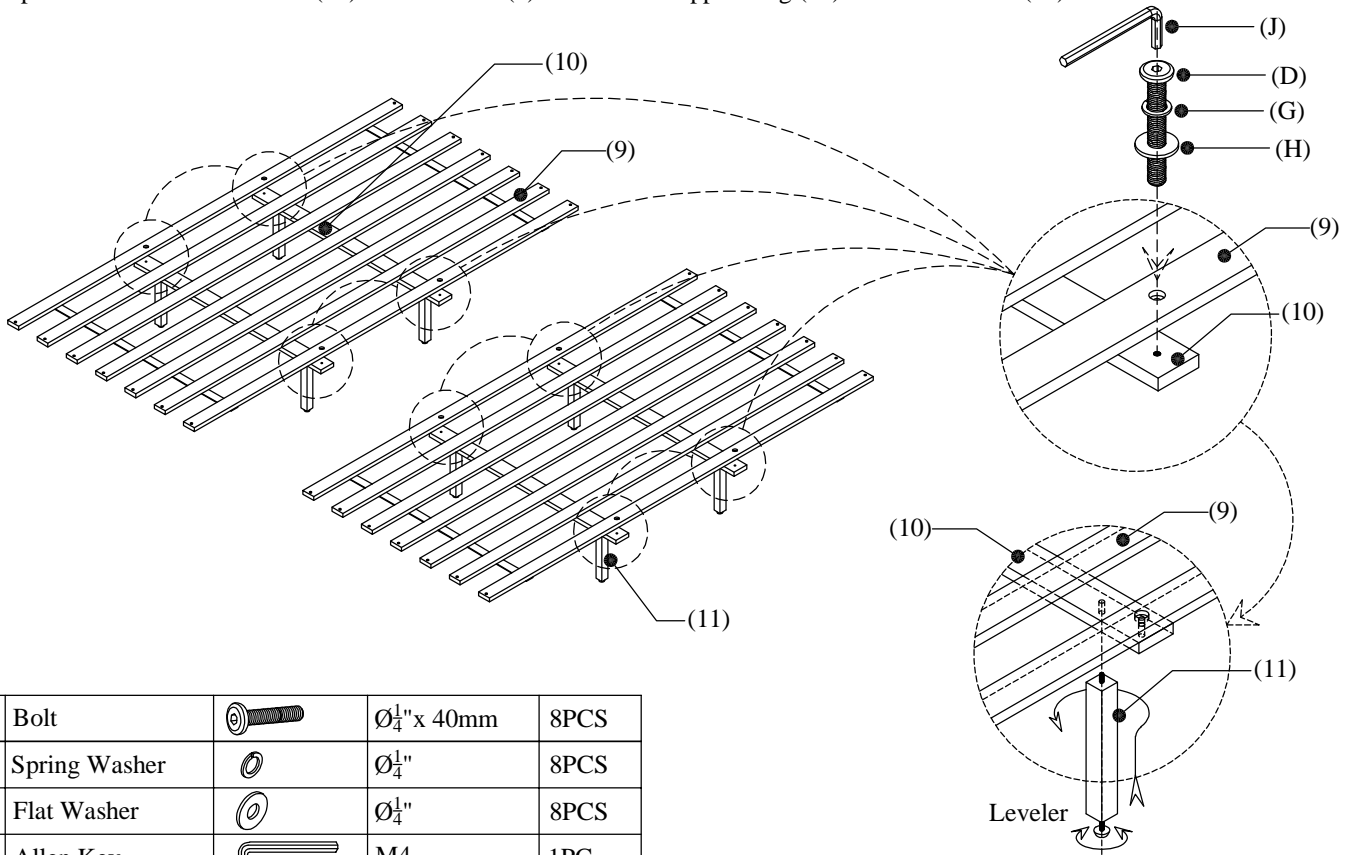

# ASSEMBLY INSTRUCTIONS

DESCRIPTION: KING BED

Step 11: Assemble Center Rail (10) with Slat roll (9) and Center Support Leg (11) with Center Rail (10).



D	Bolt		Ø¼" x 40mm	8PCS
G	Spring Washer		Ø¼"	8PCS
H	Flat Washer		Ø¼"	8PCS
J	Allen Key		M4	1PC

Step 12: Place Slats roll (9), Center rails (10), Support leg (11) in the center of the bed. Attach slats roll (9) to support rails.

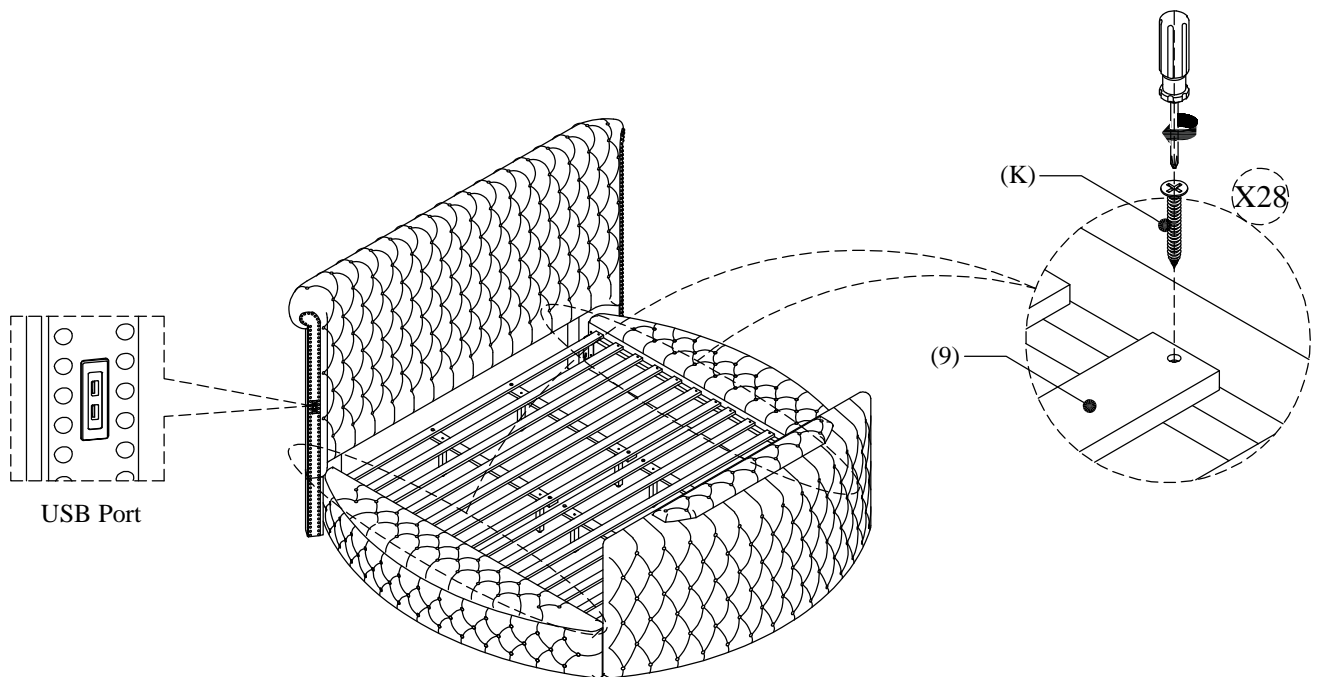

COMPLETE

K	Screw		M4x 35mm	28PCS
---	-------	---	----------	-------

MADE IN VIETNAM

PAGE 7 OF 7

# ASSEMBLY INSTRUCTIONS

DESCRIPTION: QUEEN BED

Caution: Please read instructions thoroughly before unpacking assembly parts. Sharp, exposed staple tips can cause injury, therefore, for your protection, please remove any exposed staple used in packing.

1. We recommend that you should assemble this product with the assistance of another person; this will make assembly easier, and will help to eliminate damage to the product or injury to persons during assembly.
2. Be sure to check all packing materials carefully for small parts that may have come lose inside the carton during shipment.
3. Please do not over tighten screws or bolts until the assembly is completed.
4. Please put all parts on a non-abrasive floor before assembly, and follow the assembly steps to assemble your newly purchased product correctly and efficiently.

## TOOLS REQUIRED (Not provided)

PHILLIPS SCREWDRIVER

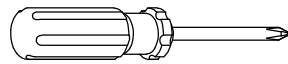

## HARDWARE LIST :

No.	Description	Sketch	Size	Quality
A	Bolt		$\text{Ø}\frac{5}{16}$ " x 60mm	8PCS
B	Bolt		$\text{Ø}\frac{5}{16}$ " x 45mm	8PCS
C	Bolt		$\text{Ø}\frac{1}{4}$ " x 20mm	8PCS
D	Bolt		$\text{Ø}\frac{1}{4}$ " x 40mm	12PCS
E	Spring Washer		$\text{Ø}\frac{5}{16}$ "	16PCS
F	Flat Washer		$\text{Ø}\frac{5}{16}$ "	16PCS
G	Spring Washer		$\text{Ø}\frac{1}{4}$ "	20PCS
H	Flat Washer		$\text{Ø}\frac{1}{4}$ "	20PCS
J	Allen Key		M4	1PC
K	Screw		M4x 35mm	28PCS
L	Metal Hook Left			2PCS
M	Metal Hook Right			2PCS

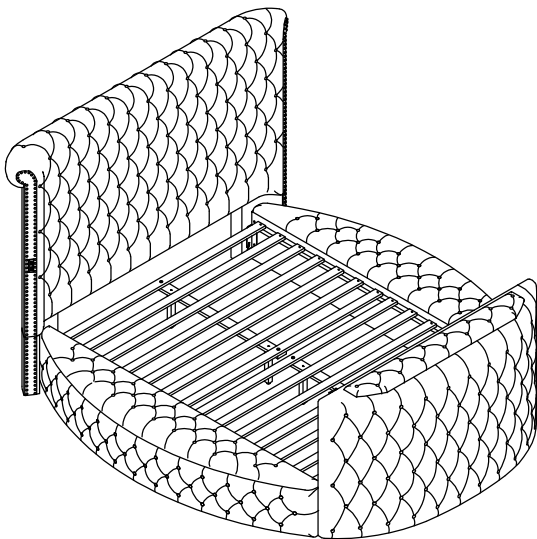

## PART LIST :





(1)	Headboard		1PC
(2)	Headboard Leg- Left		1PC
(3)	Headboard Leg- Right		1PC
(4)	Footboard		1PC
(5)	Side Rail ( Cap)		2PCS
(6)	Side Rail ( Outer Panel)		2PCS
(7)	Side Rail ( Inner Panel)		2PCS
(8)	Side Rail ( Bottom Panel)		2PCS
(9)	Slats roll		2Set
(10)	Center Rail		2PCS
(11)	Center Support Leg		4PCS
(12)	Mains Power Lead (3m)		1PC
(13)	TV Lift Remote		1PC

# ASSEMBLY INSTRUCTIONS

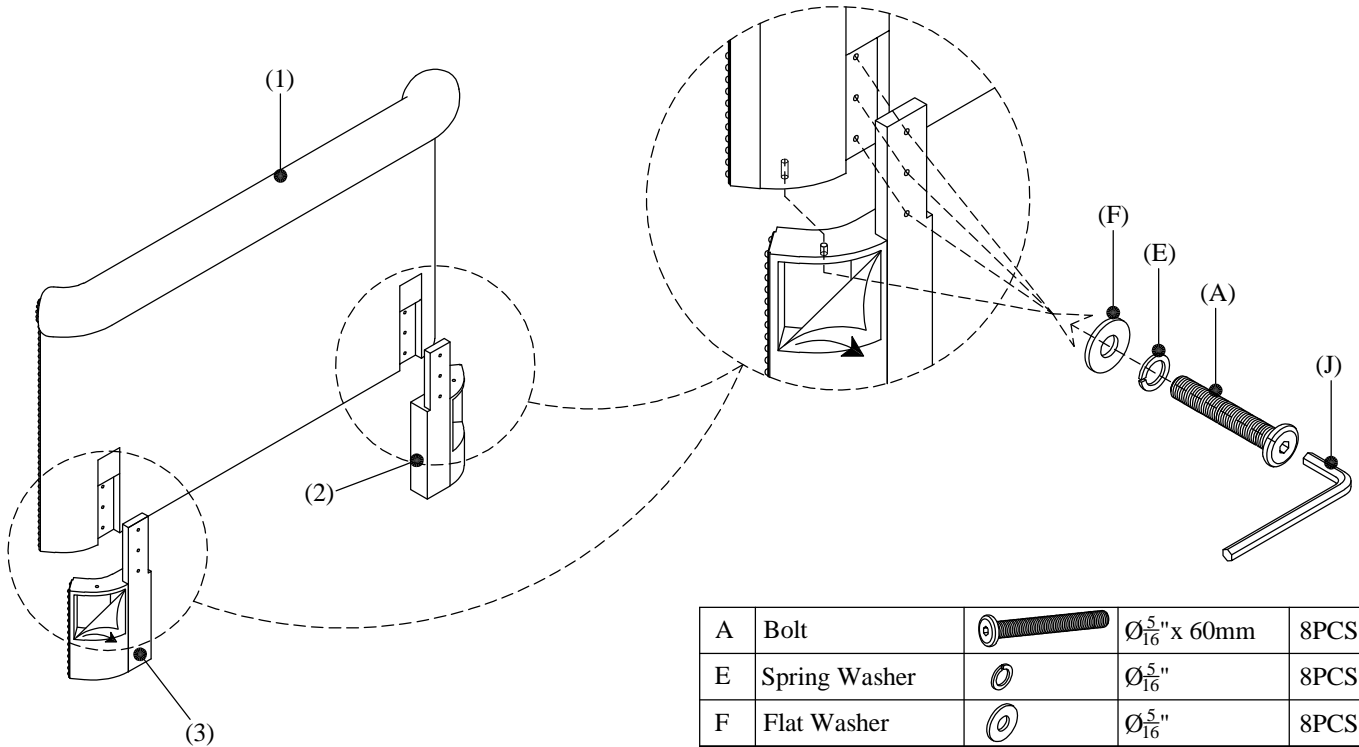
DESCRIPTION: QUEEN BED





Step 1: Assemble Headboard (1) with Headboard Leg (2)&(3).

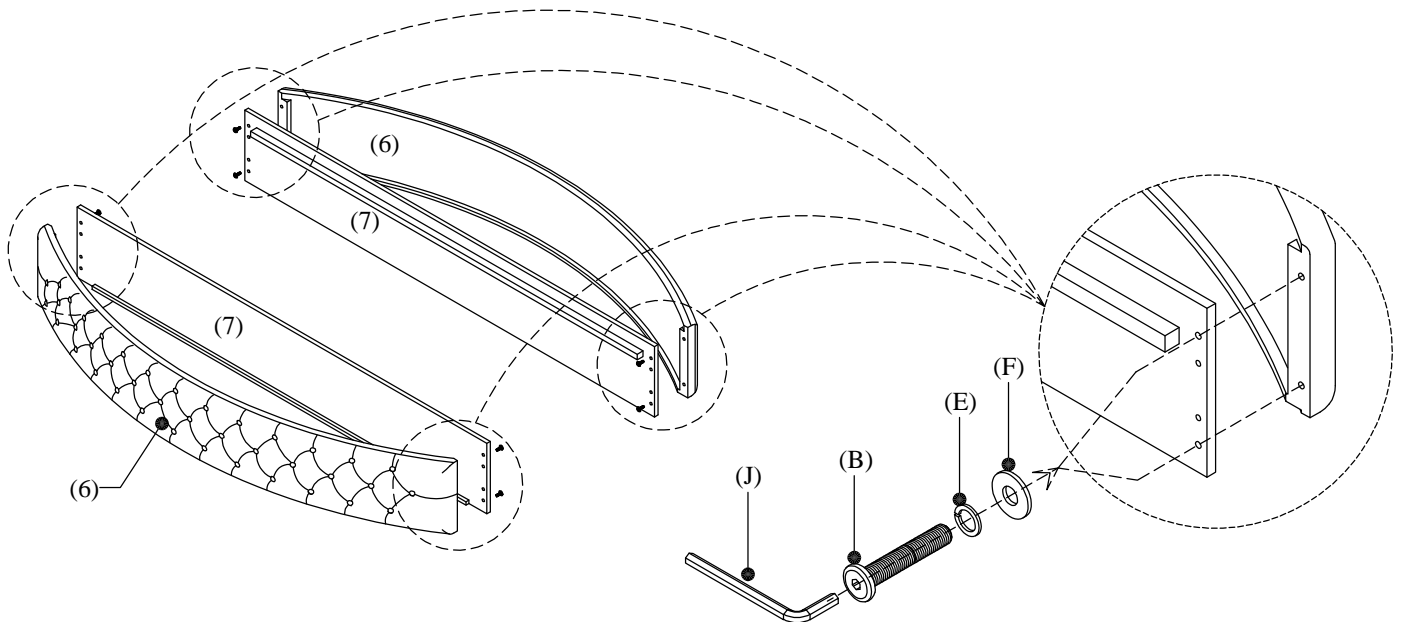

A	Bolt		$\text{Ø}\frac{5}{16}'' \times 60\text{mm}$	8PCS
E	Spring Washer		$\text{Ø}\frac{5}{16}''$	8PCS
F	Flat Washer		$\text{Ø}\frac{5}{16}''$	8PCS
J	Allen Key		M4	1PC

Step 2: Assemble Side Rail (Outer Panel) (6) with Side Rail (Inner Panel) (7).







B	Bolt		$\text{Ø}\frac{5}{16}'' \times 45\text{mm}$	8PCS
E	Spring Washer		$\text{Ø}\frac{5}{16}''$	8PCS
F	Flat Washer		$\text{Ø}\frac{5}{16}''$	8PCS
J	Allen Key		M4	1PC



# ASSEMBLY INSTRUCTIONS

DESCRIPTION: QUEEN BED

Step 3: Assemble Side rail with Metal Hook Left (L) & Metal Hook Right (M). Place Side rail (Bottom Panel) (8) inside the of Side rail storage.



C	Bolt		$\text{Ø}\frac{1}{4}'' \times 20\text{mm}$	8PCS
G	Spring Washer		$\text{Ø}\frac{1}{4}''$	8PCS
H	Flat Washer		$\text{Ø}\frac{1}{4}''$	8PCS
J	Allen Key		M4x 4"L	1PC

L	Metal Hook Left			2PCS
M	Metal Hook Right			2PCS

Step 4: Place Side rail( Cap) (5) on top of the side rail storage.

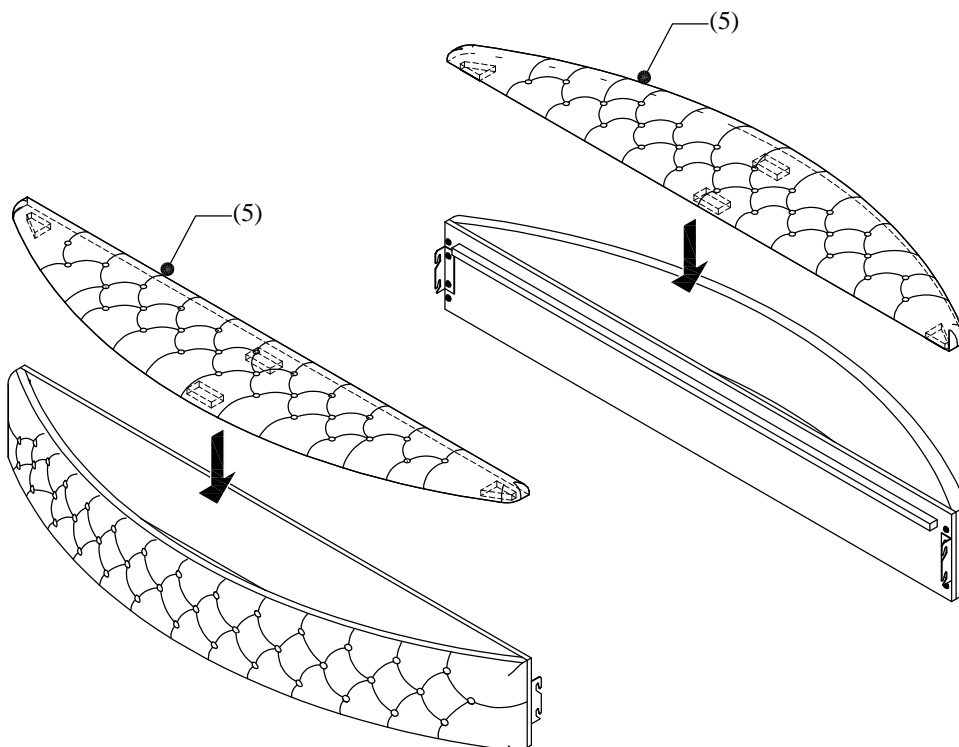



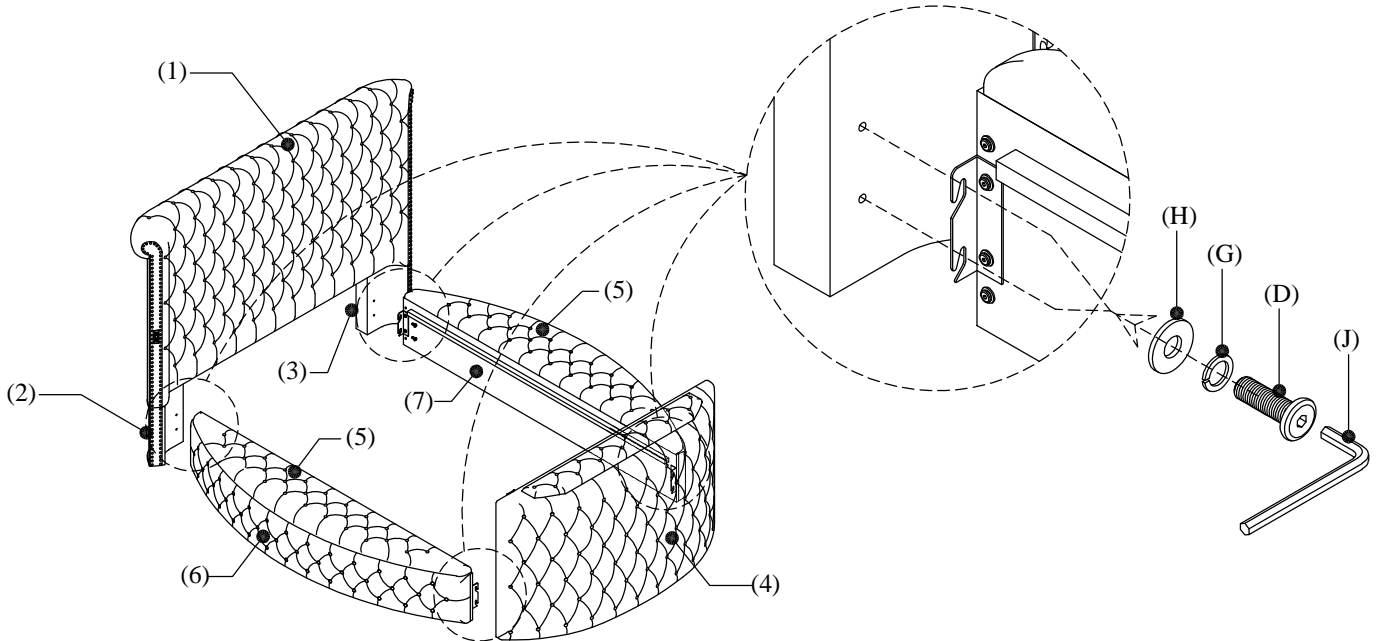

# ASSEMBLY INSTRUCTIONS

DESCRIPTION: QUEEN BED

Step 5: Assemble Side Rail with Headboard leg & Footboard (4).



D	Bolt		Ø $\frac{1}{4}$ "x 40mm	8PCS
G	Spring Washer		Ø $\frac{1}{4}$ "	8PCS
H	Flat Washer		Ø $\frac{1}{4}$ "	8PCS
J	Allen Key		M4x 4"L	1PC

Step 6: Connect Main Power Lead (12) to your wall socket - for safety, this must be an earthed supply

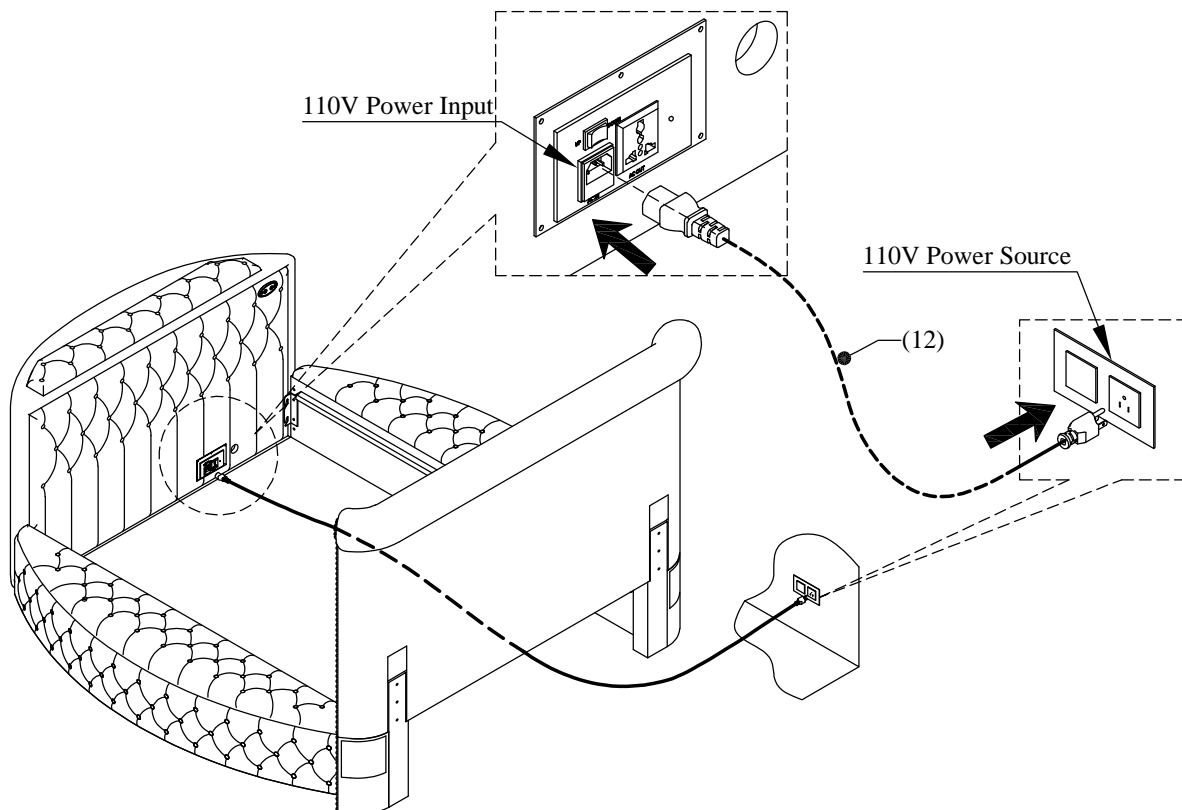

# ASSEMBLY INSTRUCTIONS

DESCRIPTION: QUEEN BED

Step 7: Press the "UP" button to raise the TV lift frame.

There are two different ways to raise up the TV lift frame:

1. Use the manual control which as show (A) press on button



2. Use remote control press on button

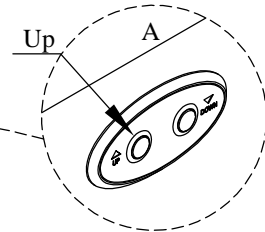

Use the manual control

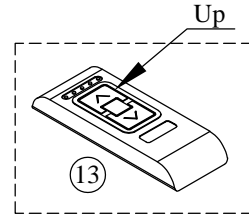

Use remote control

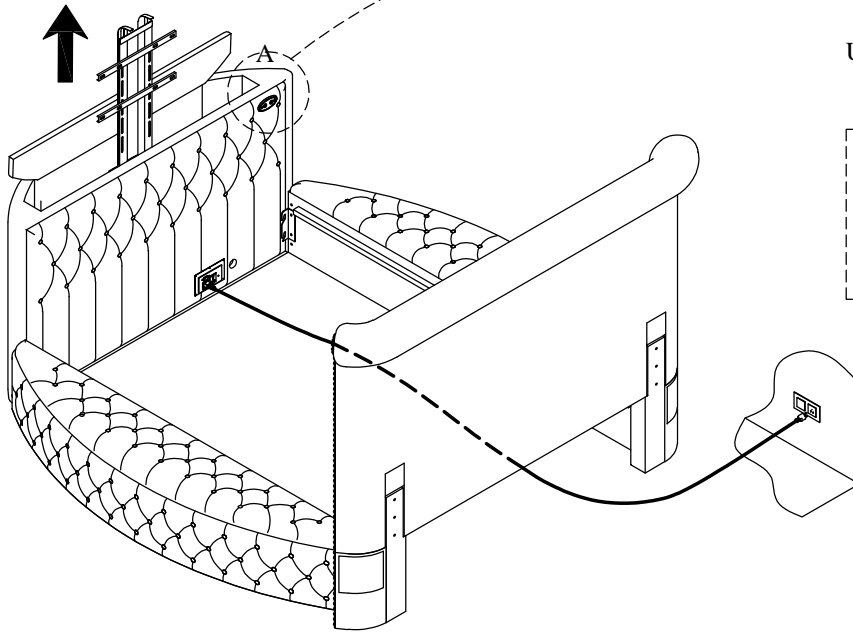

Step 8: Assemble your TV on TV lift frame in footboard.

TV INSTALLATION KIT (supplied with your TV )

a	Screw-Washer set (M8/M6/M4)		x4
b	Allen Key (5mm/4mm/2.5mm)		x1

Warning: TV maximum size  
50" Length x 28" Width x 4" Thickness

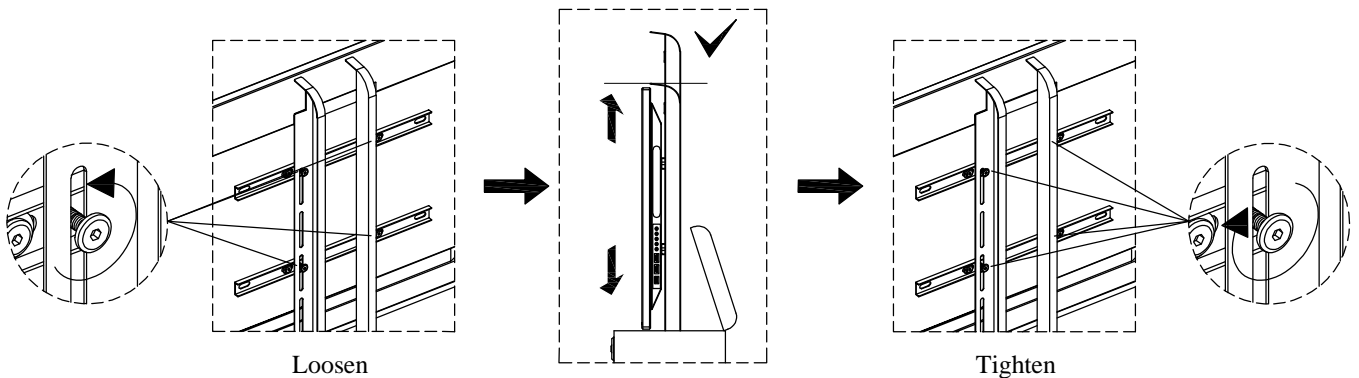
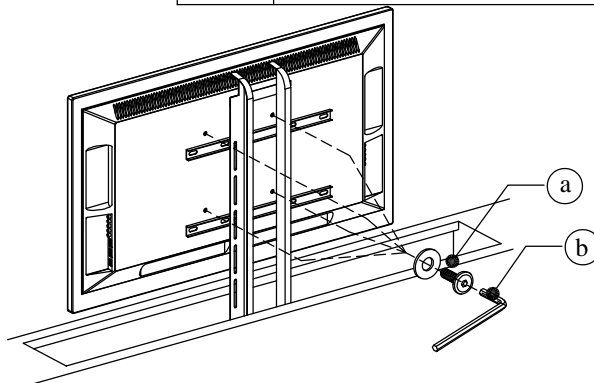
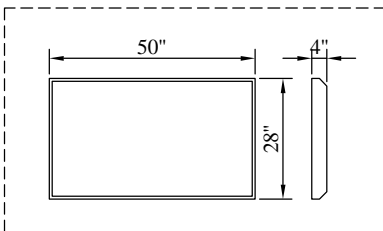

# ASSEMBLY INSTRUCTIONS

DESCRIPTION: QUEEN BED

Step 9: Press the "DOWN" button to lower the TV lift frame.

There are two different ways to lower down the TV lift frame:

1. Use the manual control which as show (A) press on button



2. Use remote control press on button

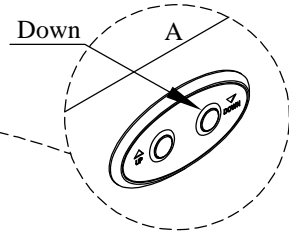

Use the manual control

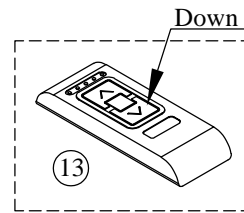

Use remote control

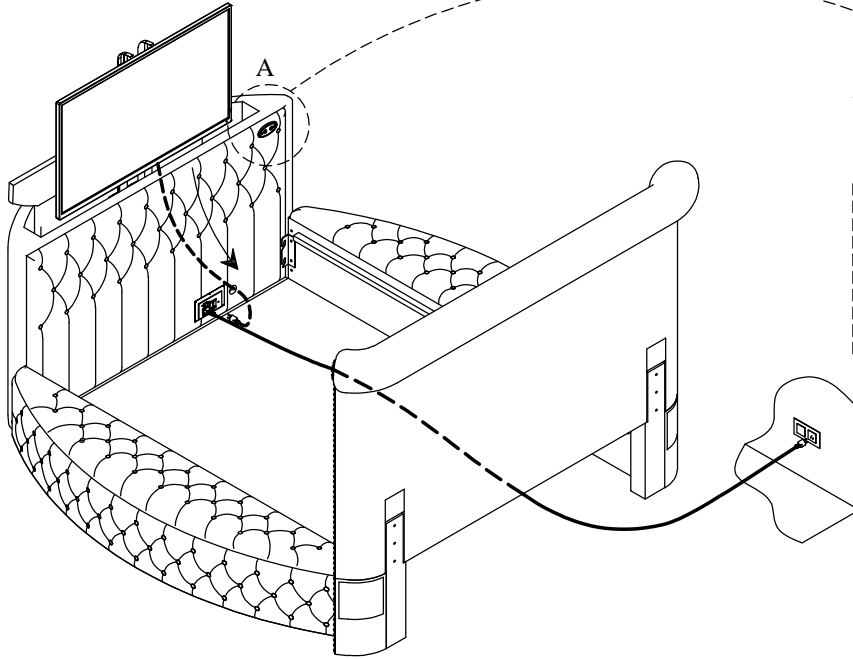

Step 10: Connect your TV electric with the output 110V socket.

Plug in the wire of USB with USB adaptor, then connect with power.

Connect your TV electric from this output 110V

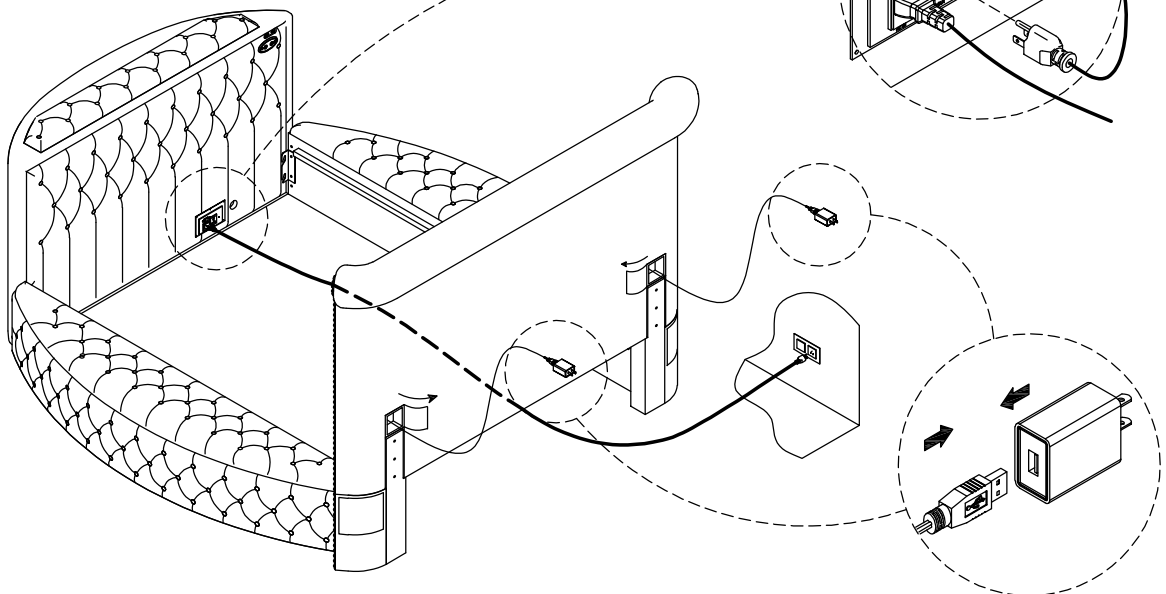
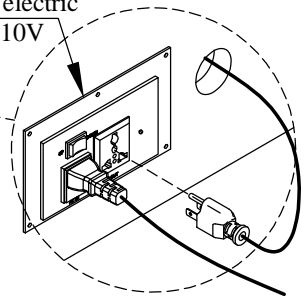



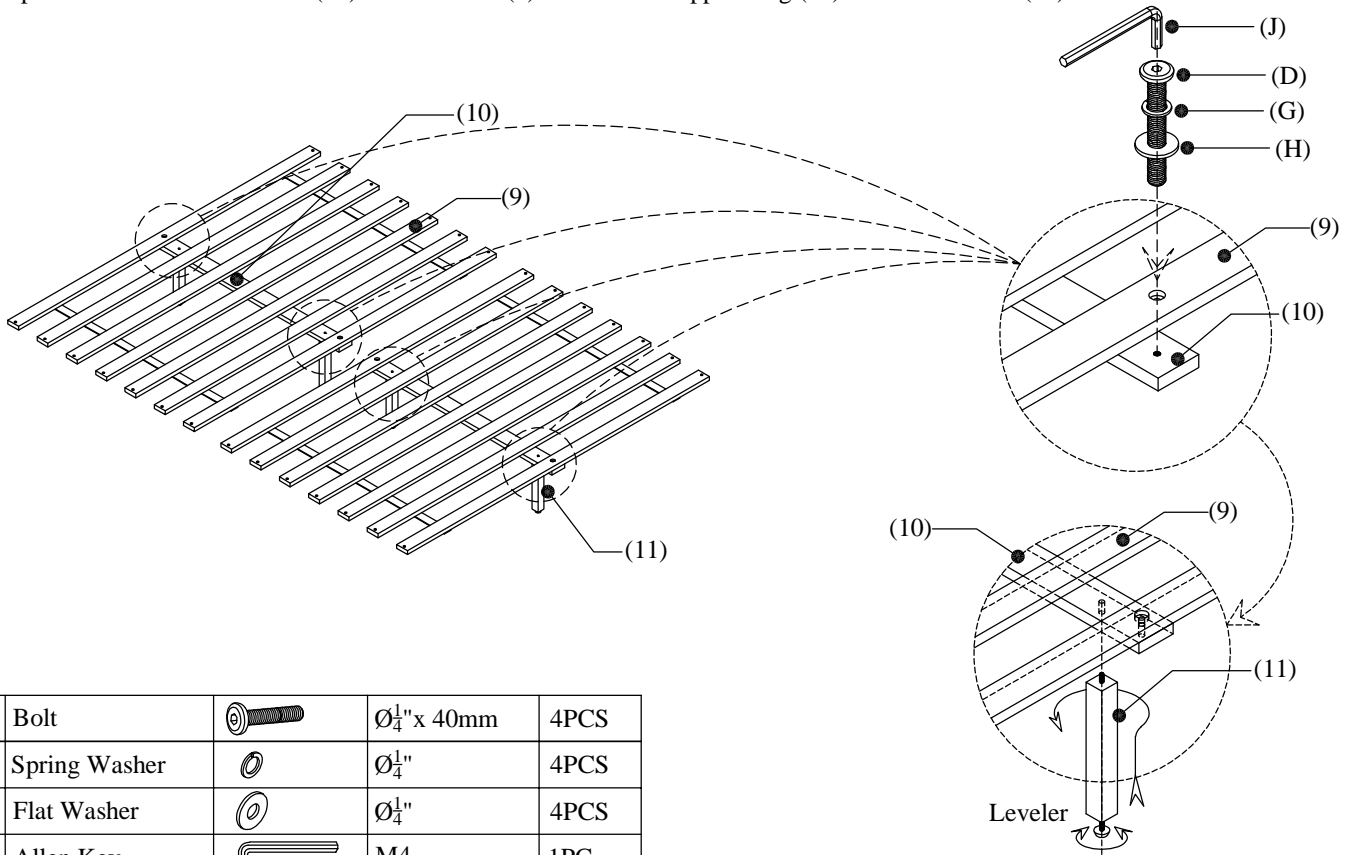

# ASSEMBLY INSTRUCTIONS

DESCRIPTION: QUEEN BED

Step 12: Assemble Center Rail (10) with Slat roll (9) and Center Support Leg (11) with Center Rail (10).



D	Bolt		Ø $\frac{1}{4}$ " x 40mm	4PCS
G	Spring Washer		Ø $\frac{1}{4}$ "	4PCS
H	Flat Washer		Ø $\frac{1}{4}$ "	4PCS
J	Allen Key		M4	1PC

Step 13: Place Slats roll (9), Center rails (10), Support leg (11) in the center of the bed. Attach slats roll (9) to support rails.

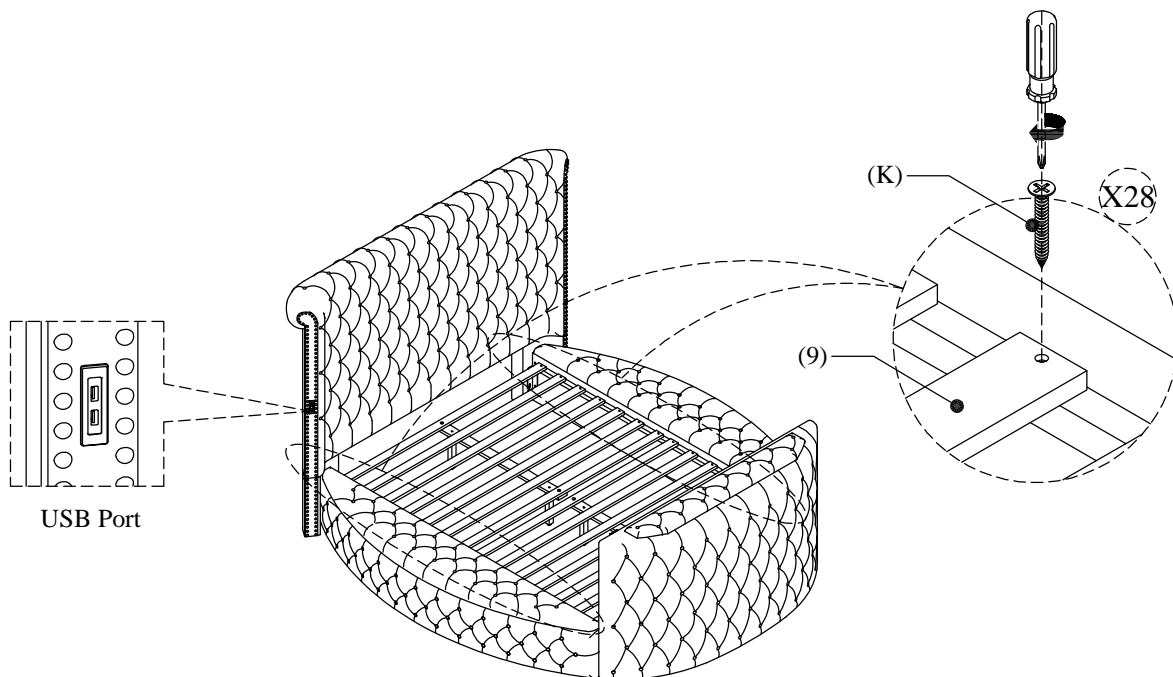

COMPLETE

K	Screw		M4x 35mm	28PCS
---	-------	---	----------	-------

MADE IN VIETNAM

PAGE 7 OF 7