

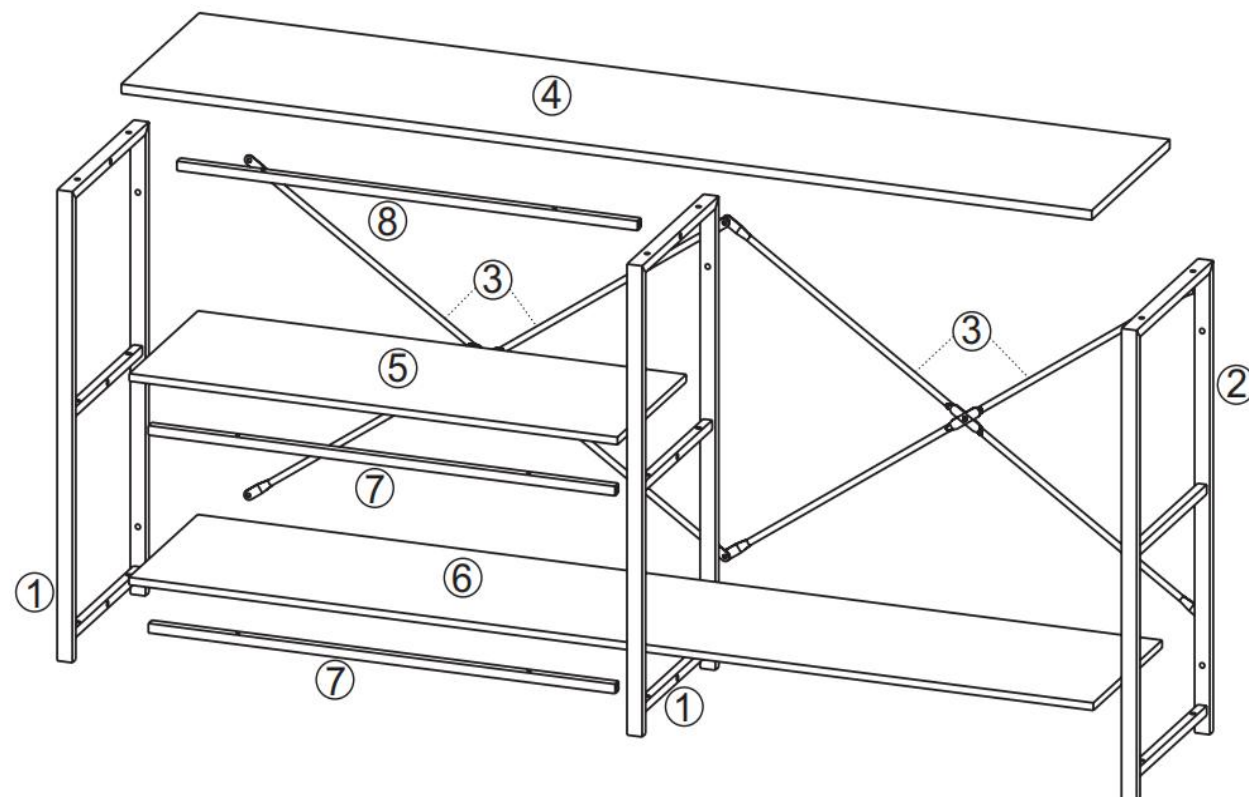

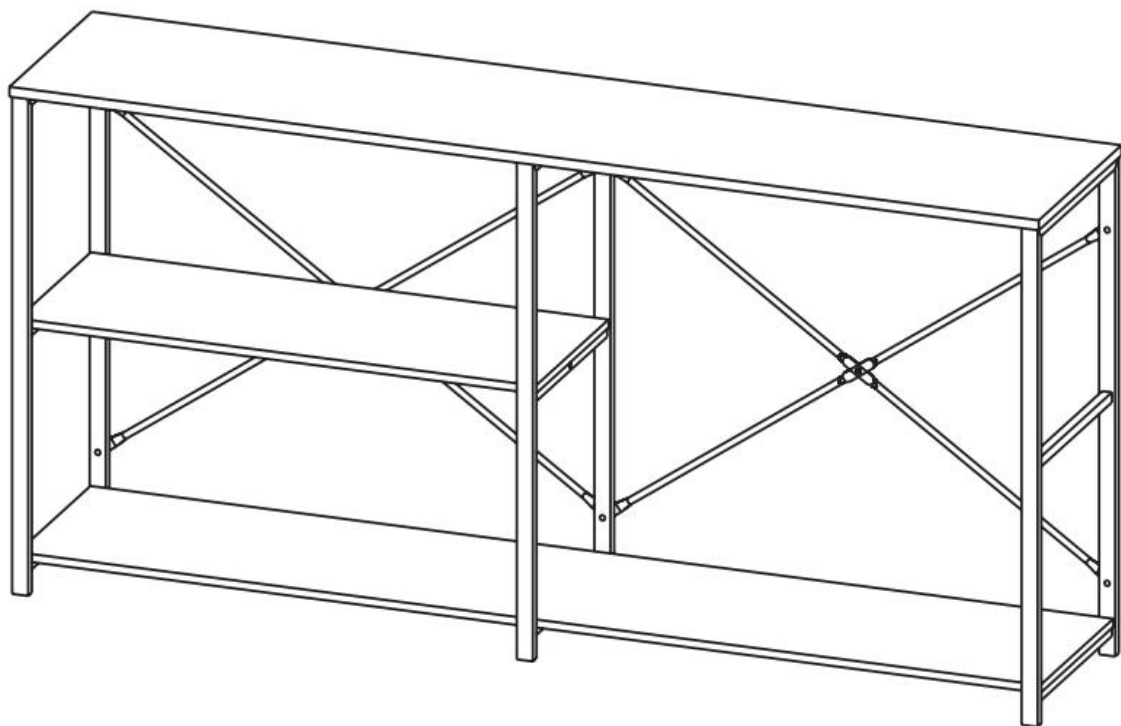

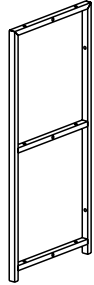









SOFA TABLE ASSEMBLY INSTRUCTION

SOFA TABLE

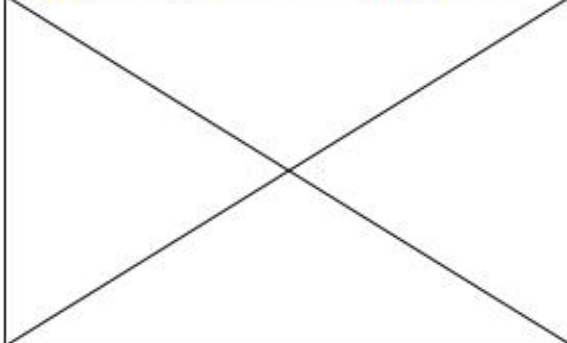
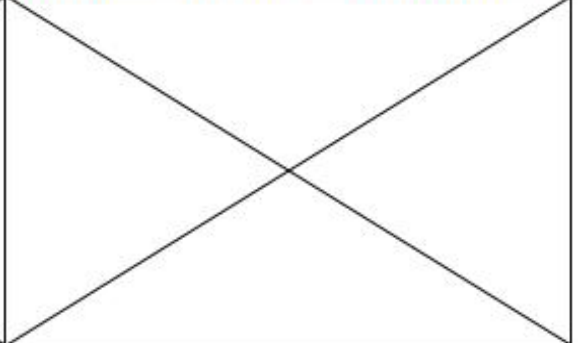

Parts & Hardware

<p>①</p>  <p>Side Frame-1 2PCS</p>	<p>②</p>  <p>Side Frame-2 1PC</p>	<p>③</p>  <p>Back Support Bar 4PCS</p>	<p>④</p>  <p>Top Panel 1PC</p>
<p>⑤</p>  <p>Middle Shelf 1PC</p>	<p>⑥</p>  <p>Bottom Shelf 1PC</p>	<p>⑦</p>  <p>Middle-Bottom Cross Rail 2PCS</p>	<p>⑧</p>  <p>Top Cross Rail 1PC</p>
<p>A</p>  <p>Long Bolt(M6*35MM) 6PCS</p>	<p>B</p>  <p>Bolt(M6X25mm) 22PCS</p>	<p>C</p>  <p>Sharp Bolt(ST4*25MM) 6PCS</p>	<p>D</p>  <p>Small Bolt(M6*10MM) 2PCS</p>
<p>E</p>  <p>Nut(M6) 8PCS</p>	<p>F</p>  <p>Allen Key 1PC</p>		

SOFA TABLE ASSEMBLY INSTRUCTION

Step 1: Please assemble this sofa table onto a clean smooth surface such as carpet or cardboard. Attach Middle Shelf(5) to middle rail of 2 Side Frame-1(1) by inserting 4 Bolts(B). Next attach the Middle-Bottom Cross Rail(7) to Middle Shelf(5), insert 2 Long Bolts(A) into 2 Side Frame-1(1) and Middle-Bottom Cross Rail(7) as shown. Tighten them with supplied Allen Key(F). Do not fully tighten all bolts until all parts are in place.

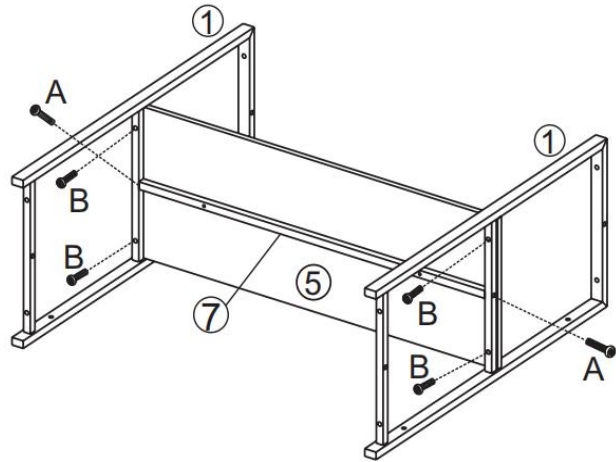

Step 2: Attach Bottom Shelf(6) to assembled part by inserting 6 Bolts(B) as shown. Then attach Middle-Bottom Cross Rail(7) to Bottom Shelf(6), insert 2 Long Bolts(A) into 2 Side Frame-1(1). Tighten them with supplied Allen Key(F). Next, attach the Side Frame-2(2) to Bottom Shelf(7) by inserting 2 Bolts(A). Tighten them with supplied Allen Key(F). Do not fully tighten all bolts until all parts are in place.

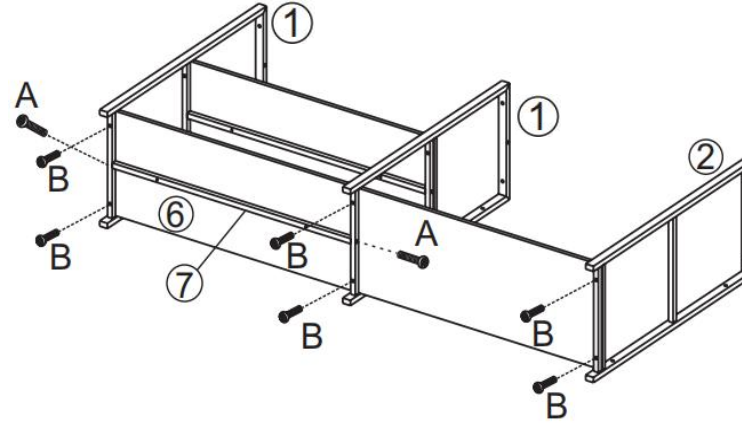

Step 3: Attach Top Panel (4) to 2 Side Frame-1(1) and Side Frame-2(2) by inserting 6 Bolts(B) as shown. Then tighten with supplied Allen Key(F). Next, attach Top Cross Rail(8) to Top Panel(4), insert 2 Long Bolts(A) into 2 Side Frame-1(1), tighten them with supplied Allen Key(F). Do not fully tighten all bolts until all parts are in place.

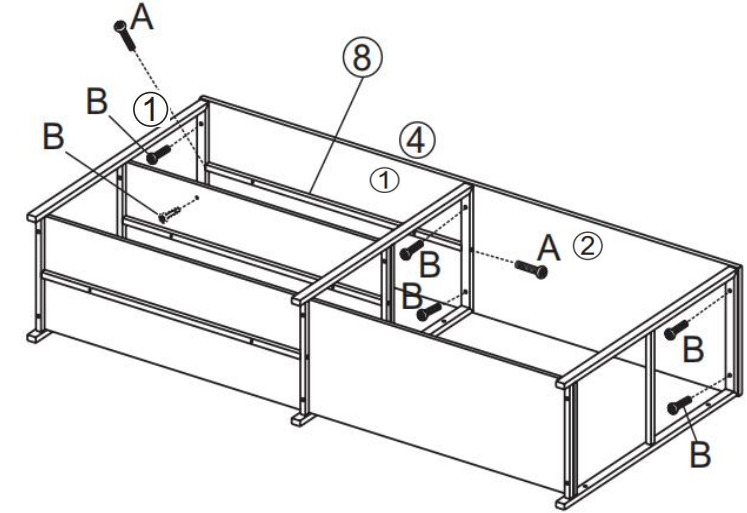

Step 4: Insert 6 SharpBolts(C) into 2 Middle-Bottom Cross Rail(7) and Top Cross Rail(8) as shown, then tighten with supplied Allen Key(F). Do not fully tighten all bolts until all parts are in place.

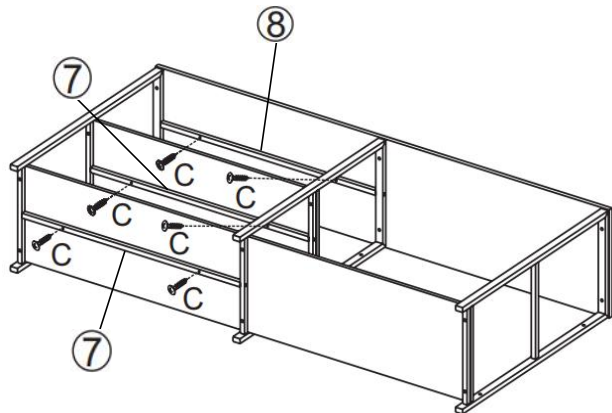

Step 5: Fasten the 4 Back Support Bar (3) with Bolt (D) and Nut (E) as shown.

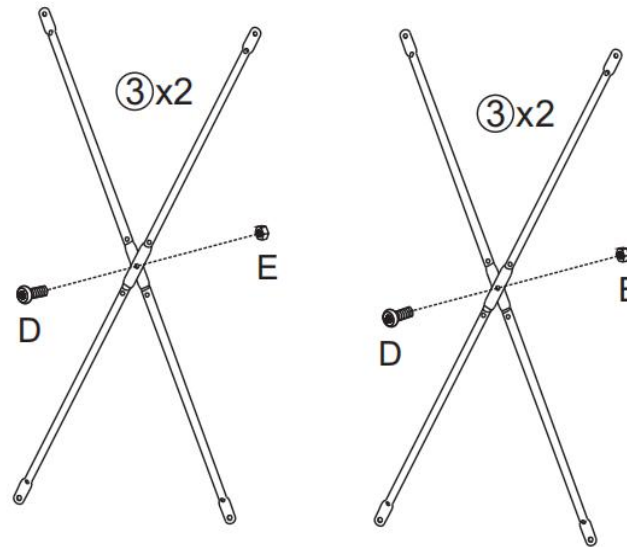

Step 6: With the help of another person, flip on the assembled part gently to make it stands. Attach the assembled Back Support Bar (3) to Side Frame-1(1) and Side Frame-2(2), insert 2 Bolts(B) and 2 Nuts(E) as shown. Attach the assembled 2 Back Support Bar(3) to 2 Side Frame-1(1), insert 4 Bolts(B) and 4 Nuts(E). Finally, fully re-tighten all bolts and assemble complete.

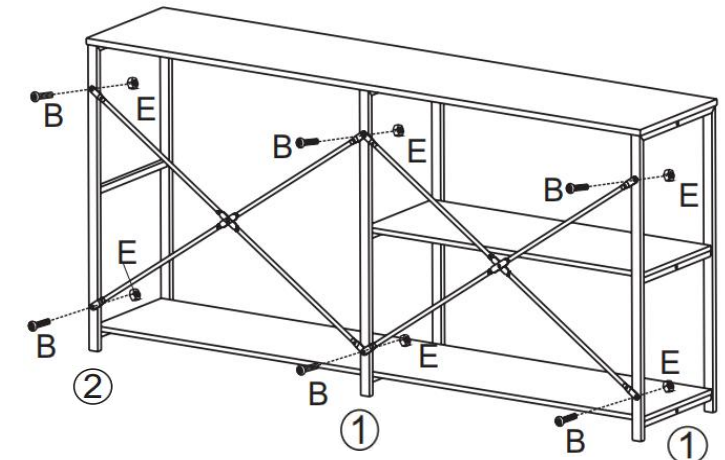

SOFA TABLE ASSEMBLY INSTRUCTION

Thank you for purchasing our sofa table. Be sure to check all packing material carefully for small parts that may have come loose inside the carton during shipment.

PRE-ASSEMBLY

- (1) Proper assembly of this item requires 2 people.
- (2) Do not dispose of any contents until assembly is completed to avoid accidentally discarding small parts or hardware.
- (3) Remove all parts and hardware from box and lay out on a carpeted or scratch-free work surface, such as the cardboard, as this will avoid damaging any parts during assembly.
- (4) Do not fully tighten all bolts until all parts are in place. Failure to follow these instructions may cause the bolts to misalign during assembly.

CARE INSTRUCTIONS

- (1) Hardware may loosen overtime. Periodically check that all connections are tight.
- (2) Wipe with a soft, dry cloth. To protect finish, avoid the use of chemicals and household cleaners.
- (3) All hot serving dishes should be placed on a pad.
- (4) Any liquid spilled onto the furniture should be cleaned up immediately with a damp cloth.

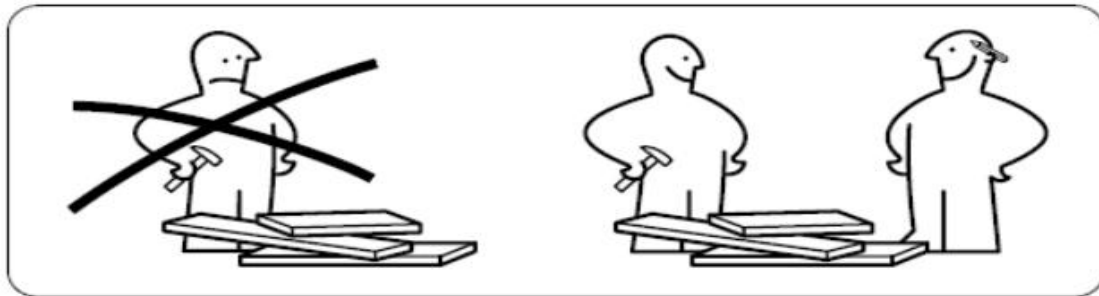

Proper assembly of this item requires 2 people

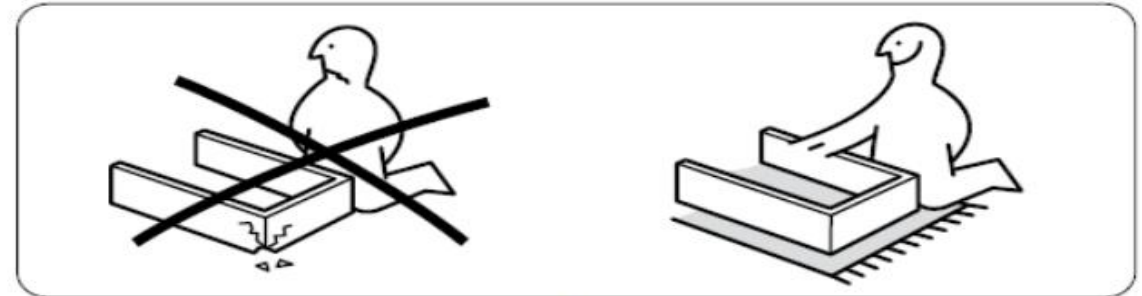

When assembling, please place it on a clean and smooth floor, such as carpet or cardboard.