

## Ivy League ide Chair INSTRUCTIONS







**Organize your parts and hardware before you begin.**



Parts :

<p><b>A:</b> Long (Front) Runner</p>  <p>Quantity: 1</p>	<p><b>C:</b> Leg (Left,Right)</p>  <p>Quantity: 2</p>	<p><b>D:</b> Seat Cushion</p>  <p>Quantity: 1</p>	<p><b>E:</b> Back Cushion</p>  <p>Quantity: 1</p>
<p><b>B:</b> Short (Back) Runner</p>  <p>Quantity: 1</p>			

Hardware :

<p><b>F:</b> Flat Bracket</p>  <p>Quantity: 4</p>	<p><b>G:</b> Wood Caps</p>  <p>Quantity: 4</p>	<p><b>H:</b> 40mm Long Bolts</p>  <p>Quantity: 4</p>	<p><b>I:</b> 20mm Flat Top Screws</p>  <p>Quantity: 8</p>	<p><b>J:</b> 25mm Round Top Screws</p>  <p>Quantity: 4</p>
<p><b>K:</b> 4mm Allen Key</p>  <p>Quantity: 1</p>	<p><b>L:</b> 5mm Allen Key</p>  <p>Quantity: 1</p>			

**IMPORTANT NOTICE:**

- Place all wooden parts on a clean and smooth surface such as a rug or carpet to avoid scratching the parts.
- Check to be sure that you have all parts and hardware.
- Remove all wrapping materials, including staples & packing straps before you start to assemble.
- Do not tighten all screws/bolts until completely assembled.
- Keep all hardware, parts and packaging out of reach of children.

## Ivy League Side Chair INSTRUCTIONS

**STEP 1:** Use 4 40mm Long Bolts(H) to attach Long (Front) Runner(A) to Legs(C) at the front of the chair and Short (Back) Runner(B) to Legs(C) at the rear.

*NOTE: Ensure that the brackets located on the runners are facing in and on the top of the runners.*

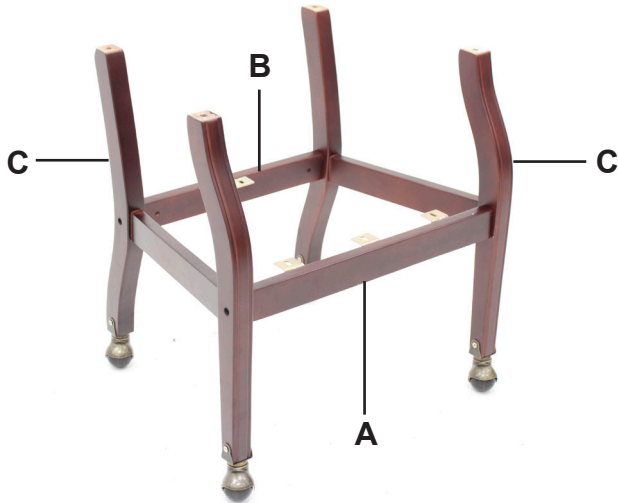

**STEP 2:** Flip assembled frame over and place Seat Cushion(D) into position. Use 4 25mm Round Screws(J) to secure the Seat Cushion to the brackets located on Long (Front) Runner(A) and Short (Back) Runner(B).

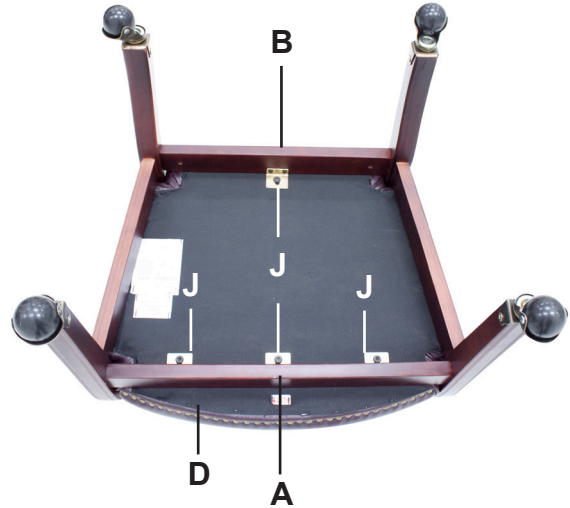

**STEP 3 :** Flip assembled frame right side up. Use 4 20mm Flat Top Screws(I) to attach the 4 Flat Brackets(F) to the top of both Legs(C).

*NOTE: DO NOT TIGHTEN SCREWS.*

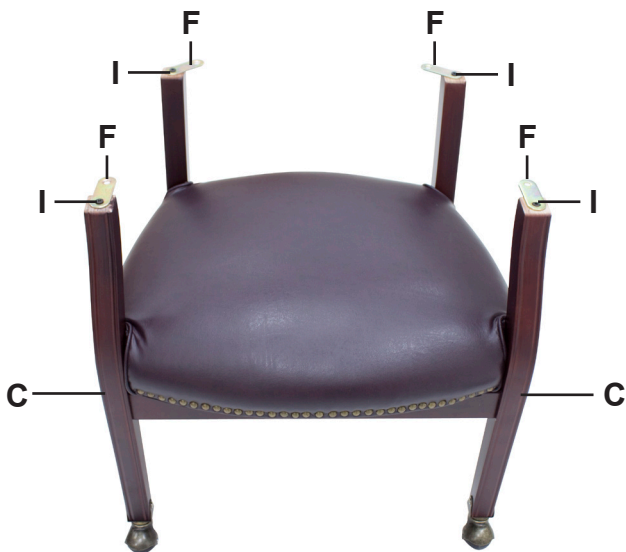

**STEP 4A:** Flip assembled frame over and place the Back Cushion(E) into position. Turn the Flat Brackets (from Step 3) until they fit into the form fitted areas on the Back Cushion. Use 4 20mm Flat Top Screws(I) to secure the cushion to the brackets. Now, tighten all bolts.

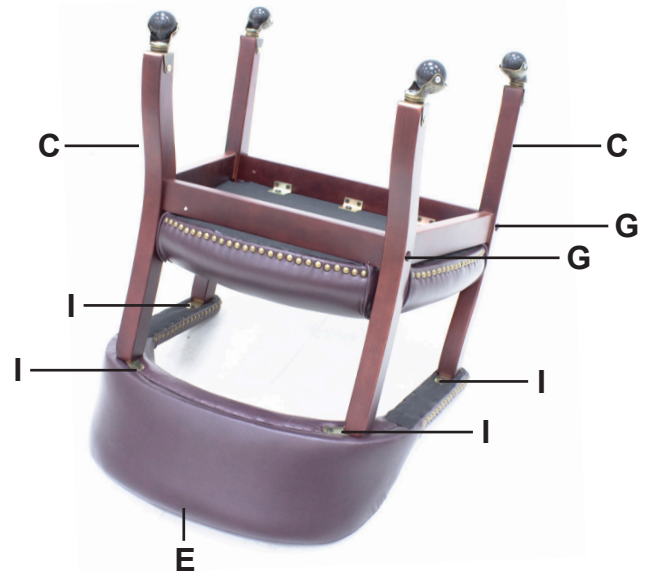

**STEP 4B:** Insert 4 Wood Caps(G) on Legs(C) to complete assembly.