

ASSEMBLY MANUAL

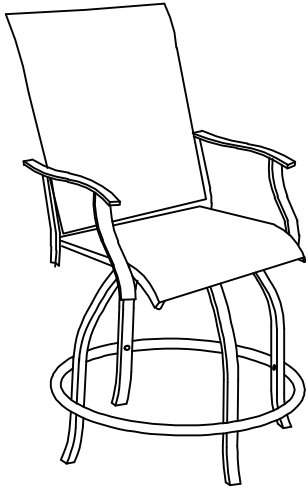







Assembly Instructions





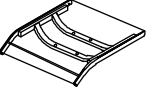
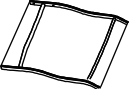





- Prior to assembly, ensure that you lay out and identify all the parts listed in the parts list.
- Tighten all nuts and bolts securely. Hand-tighten all bolts before use. Avoid using power tools or applying excessive force during assembly and bolt tightening.
- If you encounter any difficulties during assembly or if any part is missing or damaged,

Care and warranty

- The weight capacity of this recline chair is 250 lbs.
- Clean the frame components and fabric with a mild soap solution, then rinse thoroughly. Avoid using bleach, acid, or any other solvents on either the fabric or frame components.
- For a comprehensive warranty policy, Be aware that warranty terms can change without prior notification.
- For the best performance and safety of your chair, inspect and tighten all bolts and fasteners regularly

Part list

Part	Description	Qty
A	 Right Arm	1
B	 Left Arm	1
C	 Seat	1
D	 Back	1
E	 Leg	4
F	 Wheel	1
G	 Leg Connector	1
H	 M6*25 Bolt	4

Part	Description	Qty
I	 M6*15 Bolt	12
J	 M6*32 Bolt	8
K	 M6*35 Bolt	4
L	 Washer	33
M	 Nut	4
N	 Spring Washer	33
P	 Cap	28
Q	 Cap	4
S	 Allen Key	1
T	 Screw Driver	1

1. Connect the Right Arm (Part A) and Left Arm (Part B) to the Seat (Part C) using Bolt (J), Spring Washer (N), Washer (L), and Cap (P) as shown in the diagram.

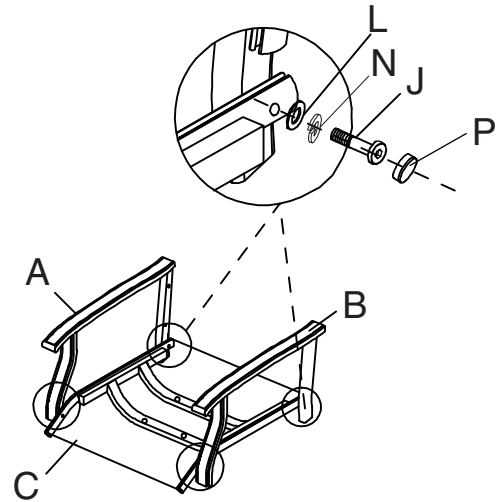

2. Connect the Back (Part D) to the Right Arm (Part A) and Left Arm (Part B) using Bolt (J), Spring Washer (N), Washer (L), and Cap (P), as shown in the diagram.

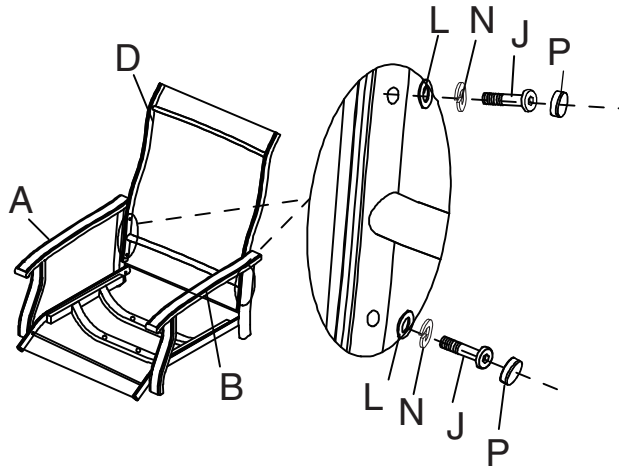

 Do not fully tighten all screws until the final step.

3. Attach Leg (Part E) and Leg Connector (Part G) using Bolt (K), Spring Washer (N), Washer (L), and Cap (P) as shown in the diagram.

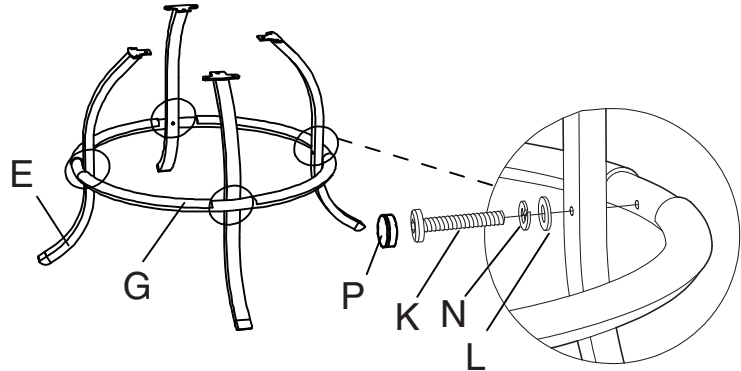

4. Attach Leg (Part E) to Wheel (Part F) using Bolt (I), Spring Washer (N), Washer (L), and Cap (P) as shown in the diagram.

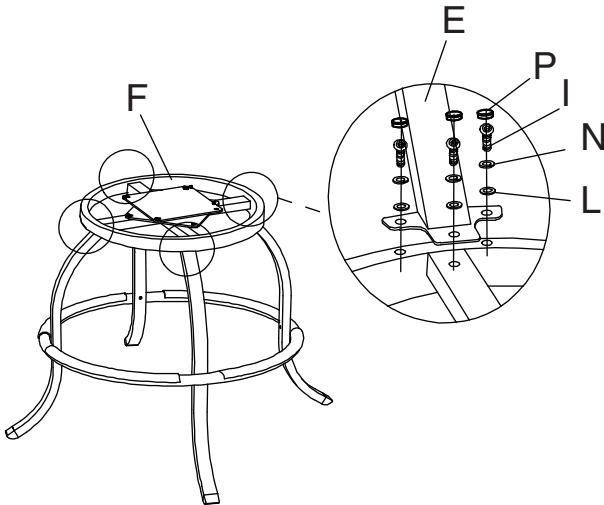

Don't fully tighten all screws until Final step.

5. Connect the finished base (Part E & F & G) to the seat (Part C) using Bolt (H), Spring Washer (N), Washer (L), Nut (M), and Caps (P & Q) as shown in the diagram.

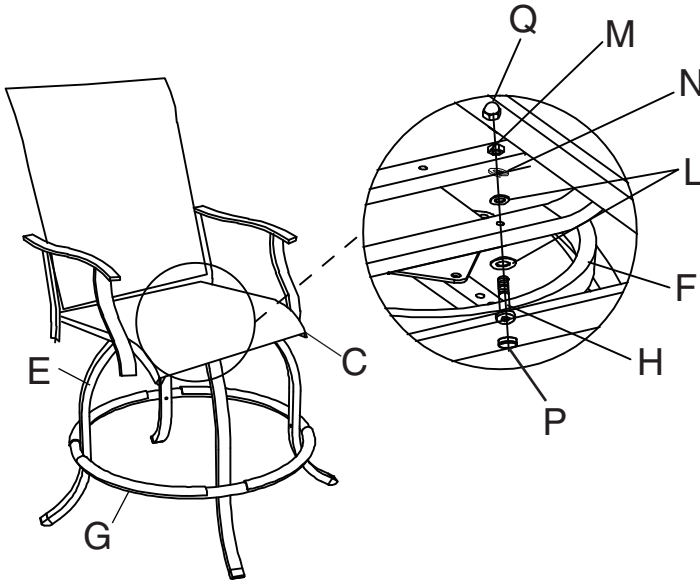

Eventually, Ensure that all bolts are securely tightened before using the product on level ground.