

# Shinco®

Dehumidifier

Model:

SDL5-10D

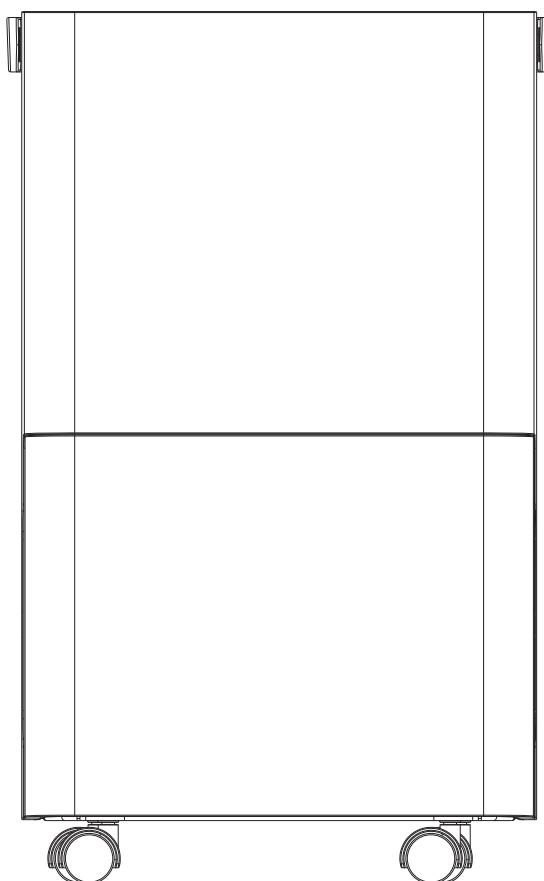



# SDL5-10D

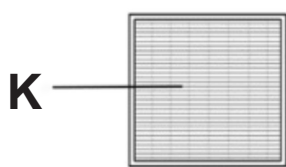
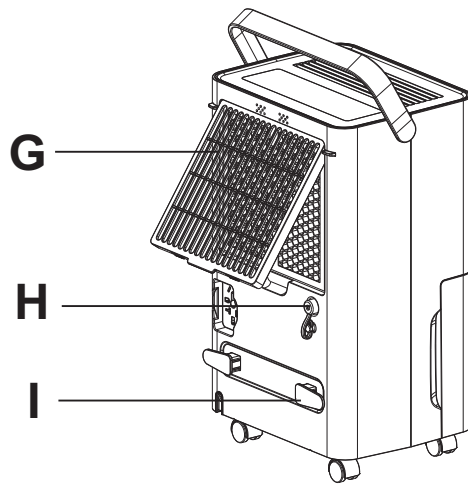
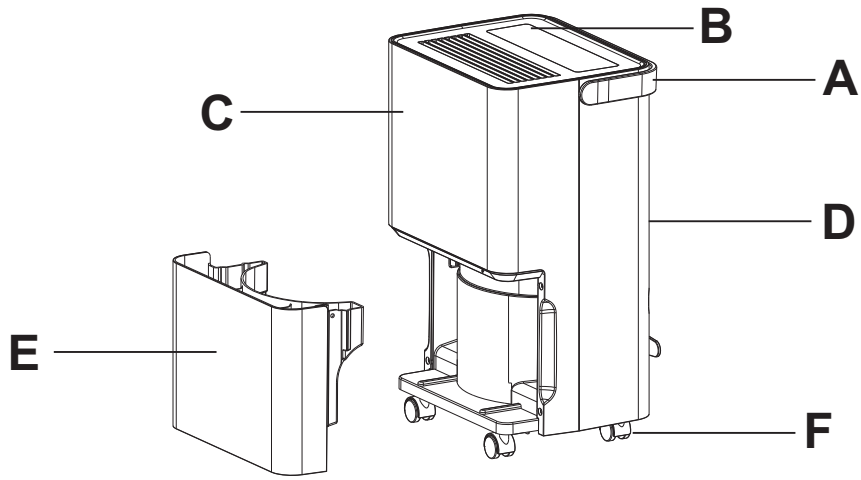

## K-Active Carbon Filter :

◆ The replacement time of the activated carbon filter depends on the frequency and location of your use, It is recommended to replace it every six months, not more than one year at most and replacement needs to be purchased by yourself.

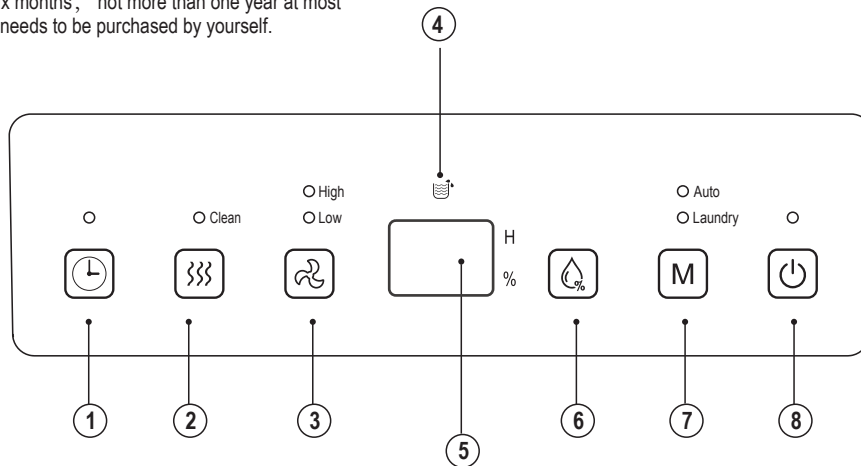

# DEHUMIDIFIER SDL5-10D

Dear customer,

Many thanks for choosing to purchase a SHINCO brand product.

Thanks to its technology, design and operation and the fact that it exceeds the strictest quality standards, a fully satisfactory use and long product life can be assured.



Please do not install or use your dehumidifier before you have carefully read this manual. Please keep this instructions manual for an eventual product warranty and for future reference.

## WARNING

- ◆ Do not use means to accelerate the defrosting process or to clean, other than those recommended by the manufacturer.
- ◆ The appliance shall be stored in a room without continuously operating ignition sources (for example: open flames, an operating gas appliance or an operating electric heater).
- ◆ Do not pierce or burn.
- ◆ Be aware the refrigerants may not contain an odour.
- ◆ Appliance shall be installed, operated and stored in a room with a floor area larger than 4 m<sup>2</sup>.

## WARNING

- ◆ Specific information regarding appliances R290 refrigerant gas.
- ◆ Thoroughly read all of the warnings.
- ◆ When defrosting and cleaning the appliance, do not use any tools other than those recommended by the manufacturing company.
- ◆ The appliance must be placed in an area without any continuously sources of ignition (for example: open flames, gas or electrical appliances in operation).
- ◆ Do not puncture and do not burn.
- ◆ This appliance contains 52 g of R290 refrigerant gas.
- ◆ R290 is a refrigerant gas that complies with the European directives on the environment. Do not puncture any part of the refrigerant circuit.
- ◆ If the appliance is installed, operated or stored in a non-ventilated area, the room must be designed to prevent to the accumulation of refrigerant leaks resulting in a risk of fire or explosion due to ignition of the refrigerant caused by electric heaters, stoves, or other sources of ignition.
- ◆ The appliance must be stored in such a way as to prevent mechanical failure.
- ◆ Individuals who operate or work on the refrigerant circuit

must have the appropriate certification issued by an accredited organization that ensures competence in handling refrigerants according to a specific evaluation recognized by associations in the industry.

- ◆ Repairs must be performed based on the recommendation from the manufacturing company. Maintenance and repairs that require the assistance of other qualified personnel must be performed under the supervision of an individual specified in the use of flammable refrigerants.

## SAFETY ADVICE AND WARNINGS

- ◆ This appliance may be used by children aged 8 years and over and persons with reduced physical, sensory or mental capabilities or lack of experience and knowledge, if they have been given appropriate supervision or training in the use of the appliance in a safe and Understand the dangers involved.
- ◆ This appliance is not a toy. Children should be supervised to ensure that they do not play with the appliance.
- ◆ Do not allow children to perform cleaning and maintenance without supervision.
- ◆ Install the appliance in accordance with national wiring regulations.
- ◆ Leave a space of 50 cm between walls or other obstacles and the appliance. Do not cover or obstruct the sides of the appliance, leaving at least 50 cm space around the appliance.
- ◆ The product requires adequate ventilation in order to function properly.
- ◆ If the mains connection is damaged, it must be replaced. Take the appliance to an authorized service center. Do not attempt to disassemble or repair it yourself as it may be dangerous.
- ◆ This appliance is intended for household use only, not for professional or industrial use.
- ◆ Before connecting the appliance, check that the voltage indicated on the nameplate matches the voltage on the rating plate.
  - ◆ Connect the appliance to a power socket that supports at least 10 amps.
  - ◆ The appliance plug must match the electrical socket of the socket. Never modify the plug. Do not use plug adapters.
  - ◆ Do not force the connecting cable. Never use the power cord to lift, carry or unplug the appliance.
  - ◆ Do not wrap the power cord around the appliance.
  - ◆ Check that the power cord is not pinched or bent.
  - ◆ Do not allow the connecting cord to hang or touch the hot surfaces of the appliance.
  - ◆ Check the condition of the electrical connection cable. Damaged or entangled cables increase the risk of electric shock.
  - ◆ It is recommended as an additional protection in the electrical installation that feeds the device, the use of a differential current device with a maximum sensitivity of 30 mA. Consult with an installer.
  - ◆ Do not touch the plug with wet hands.
  - ◆ Do not use the appliance with the damaged power cord or plug.

- ◆ If any of the enclosures of the appliance breaks, immediately switch off the appliance to avoid the possibility of electric shock.
- ◆ Do not use the appliance if it has fallen, if there are visible signs of damage, or if there is a leak.
- ◆ Use the appliance in a well-ventilated area.
- ◆ If the appliance is used in the same room with other gas or fuel appliances, it must be well ventilated.
- ◆ Do not place the appliance in direct sunlight.
- ◆ Place the appliance on a horizontal, flat, stable surface away from sources of heat and possible splashing water.
- ◆ Do not use or store the appliance outdoors.
- ◆ Do not expose the appliance to rain or moisture. Water entering the appliance will increase the risk of electric shock.
- ◆ **WARNING:** Do not use the appliance near water.
- ◆ Do not force the connecting cable. Never use the power cord to lift, carry or unplug the appliance. Keep the device away from heat sources and sharp edges.

## USE AND CARE:

- ◆ After each use, completely unplug the power cable from the power supply.
- ◆ Do not use the appliance if its start / stop device does not work. Do not remove the legs from the appliance. Do not move the appliance while it is in use.
- ◆ Use the handles to take or transport the appliance.
- ◆ Do not turn the appliance over while it is in use or connected to the mains.
- ◆ Unplug the power supply from the mains when not in use and before performing any cleaning operations.
- ◆ Keep this appliance out of the reach of children and / or persons with reduced physical, sensory or mental abilities or who are unfamiliar with its use.
- ◆ Do not expose the appliance to extreme temperatures. Keep the device in a dry, dustfree place protected from direct sunlight. Never leave the appliance unattended. It will also save energy and prolong the life of the device.
- ◆ Any improper use, or in disagreement with the instructions for use, can be dangerous, voiding the manufacturer's warranty and liability.
- ◆ Remove and empty the water tank before moving the appliance. Water spill could damage internal parts of this dehumidifier.
- ◆ Use the handle with the assistance of the casters\* to take or transport the appliance in order to avoid injuries and facilitate the transportation.

## SERVICE

- ◆ Make sure that the appliance is serviced only by specialist personnel, and that only original spare parts or accessories are used to replace existing parts/ accessories.
- ◆ Any improper use, or in disagreement with the instructions for use, can be dangerous, voiding the manufacturer's warranty and liability.

## DESCRIPTION

- A Handle
- B Control Panel
- C Front Panel
- D Back Panel
- E Water Tank
- F Casters
- G Filter Frame
- H Drainage Outlet
- I Power Cord Storage Column
- J Drainage Hose
- K Active Carbon Filter

## CONTROL PANEL

- 1 Timer
- 2 Clean
- 3 Air speed

- 4 Full tank
- 5 LED display
- 6 Humidity control
- 7 Mode/Laundry
- 8 ON/OFF

## Installation

- ◆ Be sure to remove all packaging material from inside the appliance.
- ◆ It is recommended to insert pads or damping rubber sheets, etc. under this dehumidifier to reduce vibration, noise and possible sinking of woodfloors or carpets.

## INSTRUCTIONS FOR USE

### BEFORE USE:

- ◆ Make sure that all products' packaging has been removed.
- ◆ Some parts of the appliance have been lightly greased. Consequently, the first time the appliance is used a light smoke may be detected. After a short time, this smoke will disappear.
- ◆ To eliminate the smell given off by the appliance when used for the first time, it is recommended to have it on at full power for 2 hours in a well-ventilated room.

### USE:

- ◆ Extend the cable completely before plugging in.
- ◆ Plug the appliance into the mains.
- ◆ Turn the appliance on, by using the on/off button.
- ◆ Select the desired function.

### MODE:

- ◆ Press the mode button (7) to select auto mode or laundry mode .
- ◆ In auto mode, the appliance will run until the set humidity % is reached. The default hu-midity % is 50%. For more details, see the HUMIDITY SETTING FUNCTION section.
- ◆ The laundry function, allows to reduce the time of drying clothes by reducing the humidity. To see more details about this mode, see the LAUNDRY FUNCTION section.
- ◆ The pilot light above indicates which mode is selected.

### TIMER FUNCTION:

- ◆ Press the timer button (1) to initiate this function.
- ◆ The LED display screen (5) will show the time that is selected.
- ◆ Adjust the desired time by pressing the button as many times as hours desired (1-24h). Every press adjusts one hour.
- ◆ Once you reach the desired time, stop pressing the button. After five seconds, the set time is confirmed.
- ◆ The pilot light above will turn on.
- ◆ To cancel the timer setup, press twice continuously after confirming the time.

### CLEAN FUNCTION:

- ◆ Press the clean button (2) to initiate this function.
- ◆ The pilot light above will turn on.
- ◆ This function dries the inside of the appliance to prevent mold in the interior. This procedure lasts approximately 1 hour.
- ◆ The dehumidifier starts at high air speed and releases air continuously for 30 minutes. Then it turns to low speed for approximately 20 more minutes.
- ◆ To cancel this function, press the button again.
- ◆ Activate this function before storing the dehumidifier to prevent mould inside the appliance.

### HUMIDITY SETTING FUNCTION:

- ◆ Note that this function is only available with the "auto mode".
- ◆ Press the humidity setting button (6) to initiate this function.
- ◆ Once you press the button, a humidity percentage will be displayed.
- ◆ Every time you press the button the humidity % will increase by 5% until reaching the maximum of 80%, and then it will go back to 30%.
- ◆ Once you have reached the desired humidity %, stop pressing the button. The appliance will run until the room's humidity reaches 5% lower than the one chosen. The compressor will stop but the fan will keep running at the set speed.

- ◆ The LED display screen will show the humidity % selected.

#### LAUNDRY FUNCTION:

- ◆ Press the mode button (7) to select this function. The pilot light above indicates the mode selected.
- ◆ This function activates the compressor no matter the humidity in the room. This allows clothes to dry quicker.
- ◆ To cancel this function, press the button again to switch to auto mode.

#### FAN SPEED:

- ◆ Select the desired fan speed (high or low) by pressing the fan button (3).
- ◆ The pilot light will indicate which speed is selected.

#### DRAINAGE (WATER TANK):

- ◆ When the water tank is full, the full tank icon (4) will start flashing. The appliance also emits a buzzing sound to alert the user.
- ◆ When the water tank is full, the compressor and the fan will stop running.
- ◆ Proceed to remove the water tank. Place one hand on each side of the depression areas to gently remove the water tank.
- ◆ Remove the water tank and pour the water out.
- ◆ Place the tank back into the appliance to restart the dehumidifier.

#### DRAINAGE (CONTINUOUS DRAINAGE):

- ◆ If you do not want to empty the water tank every time it gets full, you can connect the drainage pipe provided (inner diameter 9mm) to the drainage outlet (H) to drain the water continuously.
- ◆ To install the pipe, locate the drain outlet, unscrew the drain cover and pull out the plug. Proceed to connect the 9mm drainage pipe to the outlet.
- ◆ The low end of the water pipe must be more than 10cm lower than the height of the water outlet.
- ◆ The end of the pipe cannot remain in water. It is highly recommended to install it on a place that allows the water to drain constantly.
- ◆ The water pipe must be kept smooth, otherwise the water may not be drained properly.
- ◆ Refer to the Fig. 1 below for clarifications on the use of continuous drainage.

#### ONCE THE APPLIANCE HAS BEEN USED:

- ◆ Stop the appliance by pressing button on/off (8)
- ◆ Unplug the appliance from the mains.
- ◆ Collect the cable by using the power cord storage column (I).
- ◆ Clean the appliance.

#### CARRY HANDLE AND CASTERS:

- ◆ This appliance has a handle on the upper part of the body (A), which facilitates comfortable transportation.
- ◆ There are four casters (F) to facilitate the transportation of the appliance and avoid injuries.

## CLEANING

- ◆ Disconnect the appliance from the mains and allow it to cool before undertaking any cleaning task.
- ◆ Clean the electrical equipment and the mains connection with a damp cloth and dry. DO NOT IMMERSE IN WATER OR ANY OTHER LIQUID.
- ◆ Clean the equipment with a damp cloth with a few drops of washing-up liquid and then dry.
- ◆ Do not use solvents, or products with an acid or base pH such as bleach, or abrasive products, for cleaning the appliance.
- ◆ Do not let water or any other liquid get into the air vents to avoid damage to the inner parts of the appliance.
- ◆ Never submerge the appliance in water or any other liquid or place it under running water.
- ◆ If the appliance is not in good condition of cleanliness, its surface may degrade and inexorably affect the duration of the appliance's useful life and could become unsafe to use.
- ◆ Then dry all parts before its assembly and storage.

#### Cleaning G PP Filter and Filter Frame:

- ◆ Clean the air filters every 2 weeks. If the air filter is blocked with dust, its effectiveness will be reduced.
- ◆ Washing the air filters by submerging them carefully in warm water with a neutral detergent, rinse them off and let them dry completely in a shady place.
- ◆ Install the filters carefully after having them cleaned.

Anomalies	Cause	Solution
The dehumidifier does not run.	Does power plug fall?	Insert power plug into socket.
	Is the water tank full of water or placed at incorrect position?	Drain water from the water tank, and then install the water tank again.
	The ambient temperature is lower than 5°C or higher than 32°C.	Normal phenomenon. The appliance does not run in these conditions for safety reasons.
The dehumidification function is not effective.	Is the room temperature or humidity too low?	Under dry conditions the dehumidification ability will reduce.
	Are the air outlet and inlet blocked?	Clean up the objects blocking the air outlet and inlet.
Air is not blown out.	Is the air filter blocked?	Clean the air filter following the previously recommended method.
Noise is abnormal during operation.	Is the dehumidifier placed improperly so that it is inclined or unstable?	Please place the dehumidifier in smooth place.
	Is the air filter blocked?	Clean the air filter following the previously recommended method.
	There is a "tittering" sound.	It is the sound of the refrigerant flowing, which is a normal phenomenon.
Water leaks.	Connection of drainage pipe becomes loose	Fasten drainage pipe.
	Drainage system is blocked	Remove obstacles and straighten out water pipe.
Frosting occurs.	The ambient temperature is low, and it is in the state waiting for defrost.	It is a normal phenomenon, and the dehumidifier has the automatic defrosting function.
If you cannot find a solution in the table, please contact the Technical Assistance Service.		

## ANOMALIES AND REPAIR

◆ If any anomaly is detected, check the following table:

Code	Problem notifications	Solution
P1	Anti-frost function	Normal phenomenon , this function will be activated when the ambient temperature falls below about 16°C. It will be activated for a period of 8 minutes every 38 minutes between 2°C-12°C and 5 minutes every 60 minutes between 12°C-16°C.
FL	The water tank is full.	Empty the water tank according to the instructions above.
LO	Room temperature is too low	Normal phenomenon , When the room temperature is $<0^{\circ}\text{C}$ , LO shown on the screen.
HI	Room temperature is too high	Normal phenomenon , When the room temperature is $>50^{\circ}\text{C}$ , HI shown on the screen.
E1	The coil sensor detects an issue.	Seek a professional to check the coil sensor and related circuits.
E2	The room temperature sensor detects an issue.	Seek a professional to check the room temperature sensor and related circuits.
CL	The appliance is drying internally.	This is normal. When the internal drying is complete , use the appliance as normal.



The appliance contains flammable refrigerant.

For eu versions of the product and / Or if applicable in your country:  
ecology and recyclability of the product

- ◆ The materials that constitute the packaging of this apparatus, are integrated in a system of collection, classification and recycling of the same. If you want to dispose of them, you can use the appropriate public containers for each type of material.
- ◆ The product is exempt from concentrations of substances which may be considered harmful to the environment.



This symbol means that if you want to dispose of the product, after the end of its life, you must deposit it by the appropriate means at the disposal of an authorized waste manager for the selective collection of Waste Electrical and Electronic Equipment (WEEE).

## INSTRUCTIONS FOR REPAIRING APPLIANCES CONTAINING R290 GENERAL INSTRUCTIONS

### Checks to the area

- ◆ Prior to beginning work on systems containing flammable refrigerants, safety checks are necessary to ensure that the risk of ignition is minimised. For repair to the refrigerating system, the following precautions shall be complied with prior to conducting work on the system.

### Work procedure

- ◆ Work shall be undertaken under a controlled procedure so as to minimise the risk of a flammable gas or vapour being present while the work is being performed.

### General work area

- ◆ All maintenance staff and others working in the local area shall be instructed on the nature of work being carried out. Work in confined spaces shall be avoided. The area around the workspace shall be sectioned off. Ensure that the conditions within the area have been made safe by control of flammable material.

### Checking for presence of refrigerant

- ◆ The area shall be checked with an appropriate refrigerant detector prior to and during work, to ensure the technician is aware of potentially flammable atmospheres. Ensure that the leak detection equipment being used is suitable for use with flammable refrigerants, i.e. nonsparking, adequately sealed or intrinsically safe.

### Presence of fire extinguisher

- ◆ If any hot work is to be conducted on the refrigeration equipment or any associated parts, appropriate fire extinguishing equipment shall be available to hand. Have a dry powder or CO<sub>2</sub> fire extinguisher adjacent to the charging area.

### No ignition sources

- ◆ No person carrying out work in relation to a refrigeration system which involves

exposing any pipe work that contains or has contained flammable refrigerant shall use any sources of ignition in such a manner that it may lead to the risk of fire or explosion. All possible ignition sources, including cigarette smoking, should be kept sufficiently far away from the site of installation, repairing, removing and disposal, during which flammable refrigerant can possibly be released to the surrounding space. Prior to work taking place, the area around the equipment is to be surveyed to make sure that there are no flammable hazards or ignition risks. "No Smoking" signs shall be displayed.

### Ventilated area

- ◆ Ensure that the area is in the open or that it is adequately ventilated before breaking into the system or conducting any hot work. A degree of ventilation shall continue during the period that the work is carried out. The ventilation should safely disperse any released refrigerant and preferably expel it externally into the atmosphere.

### Checks to the refrigeration equipment

- ◆ Where electrical components are being changed, they shall be fit for the purpose and to the correct specification. At all times the manufacturer's maintenance and service guidelines shall be followed. If in doubt consult the manufacturer's technical department for assistance. The following checks shall be applied to installations using flammable refrigerants: the charge size is in accordance with the room size within which the refrigerant containing parts are installed; the ventilation machinery and outlets are operating adequately and are not obstructed; if an indirect refrigerating circuit is being used, the secondary circuit shall be checked for the presence of refrigerant; marking to the equipment continues to be visible and legible. Markings and signs that are illegible shall be corrected; refrigeration pipe or components are installed in a position where they are unlikely to be exposed to any substance which may corrode refrigerant containing components, unless the components are constructed of materials which are inherently resistant to being corroded or are suitably protected against being so corroded.

### Checks to electrical devices

- ◆ Repair and maintenance to electrical components shall include initial safety checks and component inspection procedures. If a fault exists that could compromise safety, then no electrical supply shall be connected to the circuit until it is satisfactorily dealt with. If the fault cannot be corrected immediately but it is necessary to continue operation, an adequate temporary solution shall be used. This shall be reported to the owner of the equipment so all parties are advised.
- ◆ Initial safety checks shall include: that capacitors are discharged: this shall be done in a safe manner to avoid possibility of sparking; that there no live electrical components and wiring are exposed while charging, recovering or purging the system; that there is continuity of earth bonding.

### REPAIRS TO SEALED COMPONENTS

- ◆ During repairs to sealed components, all electrical supplies shall be disconnected from the equipment being worked upon prior to any removal of sealed covers, etc. If it is absolutely necessary to have an electrical supply to equipment during servicing, then a permanently operating form of leak detection shall be located at the most critical point to warn of a potentially hazardous situation.
- ◆ Particular attention shall be paid to the following to ensure that by working on electrical components, the casing is not altered in such a way that the level of protection is affected.
- ◆ This shall include damage to cables, excessive number of connections, terminals not made to original specification, damage to seals, incorrect fitting of glands, etc. Ensure that apparatus is mounted securely. Ensure that seals or sealing materials have not degraded such that they no longer serve the purpose of preventing the ingress of flammable atmospheres. Replacement parts shall be in accordance with the manufacturer's specifications.
- ◆ NOTE The use of silicon sealant may inhibit the effectiveness of some types of leak detection equipment. Intrinsically safe components do not have to be isolated prior to working on them.

### REPAIR TO INTRINSICALLY SAFE COMPONENTS

- ◆ Do not apply any permanent inductive or capacitance loads to the circuit without ensuring that this will not exceed the permissible voltage and current permitted for the equipment in use. Intrinsically safe components are the only types that can be worked on while live in the presence of a flammable atmosphere. The test apparatus shall be at the correct rating. Replace components only with parts specified by the manufacturer. Other parts may result in the ignition of refrigerant in the atmosphere from a leak.

### CABLING

- ◆ Check that cabling will not be subject to wear, corrosion, excessive pressure, vibration, sharp edges or any other adverse environmental effects. The check shall also take into account the effects of aging or continual vibration from sources such as compressors or fans.

## DETECTION OF FLAMMABLE REFRIGERANTS

- ◆ Under no circumstances shall potential sources of ignition be used in the searching for or detection of refrigerant leaks. A halide torch (or any other detector using a naked flame) shall not be used.

## LEAK DETECTION METHODS

- ◆ The following leak detection methods are deemed acceptable for systems containing flammable refrigerants. Electronic leak detectors shall be used to detect flammable refrigerants, but the sensitivity may not be adequate, or may need recalibration. (Detection equipment shall be calibrated in a refrigerant-free area.) Ensure that the detector is not a potential source of ignition and is suitable for the refrigerant used. Leak detection equipment shall be set at a percentage of the LFL of the refrigerant and shall be calibrated to the refrigerant employed and the appropriate percentage of gas (25 % maximum) is confirmed. Leak detection fluids are suitable for use with most refrigerants but the use of detergents containing chlorine shall be avoided as the chlorine may react with the refrigerant and corrode the copper pipework. If a leak is suspected, all naked flames shall be removed/ extinguished. If a leakage of refrigerant is found which requires brazing, all of the refrigerant shall be recovered from the system, or isolated (by means of shut off valves) in a part of the system remote from the leak. Oxygen free nitrogen (OFN) shall then be purged through the system both before and during the brazing process.

## REMOVAL AND EVACUATION

- ◆ When breaking into the refrigerant circuit to make repairs – or for any other purpose – conventional procedures shall be used. However, it is important that best practice is followed since flammability is a consideration. The following procedure shall be adhered to: remove refrigerant; purge the circuit with inert gas; evacuate; purge again with inert gas; open the circuit by cutting
- ◆ or brazing. The refrigerant charge shall be recovered into the correct recovery cylinders. The system shall be “flushed” with OFN to render the unit safe. This process may need to be repeated several times. Compressed air or oxygen shall not be used for this task. Flushing shall be achieved by breaking the vacuum in the system with OFN and continuing to fill until the working pressure is achieved, then venting to atmosphere, and finally pulling down to a vacuum. This process shall be repeated until no refrigerant is within the system. When the final OFN charge is used, the system shall be vented down to atmospheric pressure to enable work to take place. This operation is absolutely vital if brazing operations on the pipework are to take place.
- ◆ Ensure that the outlet for the vacuum pump is not close to any ignition sources and there is ventilation available.

## CHARGING PROCEDURES

- ◆ In addition to conventional charging procedures, the following requirements shall be followed.
- ◆ Ensure that contamination of different refrigerants does not occur when using charging equipment. Hoses or lines shall be as short as possible to minimise the amount of refrigerant contained in them.
- ◆ Cylinders shall be kept upright.
- ◆ Ensure that the refrigeration system is earthed prior to charging the system with refrigerant.
- ◆ Label the system when charging is complete (if not already).
- ◆ Extreme care shall be taken not to overfill the refrigeration system.
- ◆ Prior to recharging the system, it shall be pressure tested with OFN. The system shall be leak tested on completion of charging but prior to commissioning. A follow up leak test shall be carried out prior to leaving the site.

## DECOMMISSIONING

- ◆ Before carrying out this procedure, it is essential that the technician is completely familiar with the equipment and all its detail. It is recommended good practice that all refrigerants are recovered safely. Prior to the task being carried out, an oil and refrigerant sample shall
- ◆ be taken in case analysis is required prior to reuse of reclaimed refrigerant. It is essential that electrical power is available before the task is commenced.
- ◆ a) Become familiar with the equipment and its operation.
- ◆ b) Isolate system electrically.
- ◆ c) Before attempting the procedure ensure that: mechanical handling equipment is available, if required, for handling refrigerant cylinders; all personal protective equipment is available and being used correctly; the recovery process is supervised at all times by a competent person; recovery equipment and cylinders conform to the appropriate standards.
- ◆ d) Pump down refrigerant system, if possible.
- ◆ e) If a vacuum is not possible, make a manifold so that refrigerant can be removed from various parts of the system.
- ◆ f) Make sure that cylinder is situated on the scales before recovery takes place.
- ◆ g) Start the recovery machine and operate in accordance with manufacturer's instruc-

tions.

- ◆ h) Do not overfill cylinders. (No more than 80 % volume liquid charge).
- ◆ i) Do not exceed the maximum working pressure of the cylinder, even temporarily.
- ◆ j) When the cylinders have been filled correctly and the process completed, make sure that the cylinders and the equipment are removed from site promptly and all isolation valves on the equipment are closed off.
- ◆ k) Recovered refrigerant shall not be charged into another refrigeration system unless it has been cleaned and checked.

## LABELLING

- ◆ Equipment shall be labelled stating that it has been decommissioned and emptied of refrigerant. The label shall be dated and signed.
- ◆ Ensure that there are labels on the equipment stating the equipment contains flammable refrigerant.

## RECOVERY

- ◆ When removing refrigerant from a system, either for servicing or decommissioning, it is recommended good practice that all refrigerants are removed safely. When transferring refrigerant into cylinders, ensure that only appropriate refrigerant recovery cylinders are employed. Ensure that the correct number of cylinders for holding the total system charge are available. All cylinders to be used are designated for the recovered refrigerant and labelled for that refrigerant (i.e. special cylinders for the recovery of refrigerant). Cylinders shall be complete with pressure relief valve and associated shutoff valves in good working order. Empty recovery cylinders are evacuated and, if possible, cooled before recovery occurs.
- ◆ The recovery equipment shall be in good working order with a set of instructions concerning the equipment that is at hand and shall be suitable for the recovery of flammable refrigerants. In addition, a set of calibrated weighing scales shall be available and in good working order. Hoses shall be complete with leakfree disconnect couplings and in good condition. Before using the recovery machine, check that it is in satisfactory working order, has been properly maintained and that any associated electrical components are sealed to prevent ignition in the event of a refrigerant release. Consult manufacturer if in doubt.
- ◆ The recovered refrigerant shall be returned to the refrigerant supplier in the correct recovery cylinder, and the relevant Waste Transfer Note arranged. Do not mix refrigerants in recovery units and especially not in cylinders. If compressors or compressor oils are to be removed, ensure that they have been evacuated to an acceptable level to make certain that flammable refrigerant does not remain within the lubricant. The evacuation process shall be carried out prior to returning the compressor to the suppliers. Only electric heating to the compressor body shall be employed to accelerate this process. When oil is drained from a system, it shall be carried out safely.

## Competence of service personnel

### General

- ◆ Special training additional to usual refrigerating equipment repair procedures is required when equipment with flammable refrigerants is affected.
- ◆ In many countries, this training is carried out by national training organisations that are accredited to teach the relevant national competency standards that may be set in legislation.
- ◆ The achieved competence should be documented by a certificate.

### Training

- ◆ The training should include the substance of the following:
- ◆ Information about the explosion potential of flammable refrigerants to show that flammables may be dangerous when handled without care.
- ◆ Information about potential ignition sources, especially those that are not obvious, such as lighters, light switches, vacuum cleaners, electric heaters.
- ◆ Information about the different safety concepts:
- ◆ Unventilated – (see Clause GG.2) Safety of the appliance does not depend on ventilation of the housing. Switching off the appliance or opening of the housing has no significant effect on the safety. Nevertheless, it is possible that leaking refrigerant may accumulate inside the enclosure and flammable atmosphere will be released when the enclosure is opened.
- ◆ Ventilated enclosure – (see Clause GG.4) Safety of the appliance depends on ventilation of the housing. Switching off the appliance or opening of the enclosure has a significant effect on the safety. Care should be taken to ensure a sufficient ventilation before.
- ◆ Ventilated room – (see Clause GG.5) Safety of the appliance depends on the ventilation of the room. Switching off the appliance or opening of the housing has no significant effect on the safety. The ventilation of the room shall not be switched off during repair procedures.
- ◆ Information about the concept of sealed components and sealed enclosures according to IEC 60079-1:2010.

- ◆ Information about the correct working procedures:

### Commissioning

- ◆ Ensure that the floor area is sufficient for the refrigerant charge or that the ventilation duct is assembled in a correct manner.
- ◆ Connect the pipes and carry out a leak test before charging with refrigerant.
- ◆ Check safety equipment before putting into service.

### Maintenance

- ◆ Portable equipment shall be repaired outside or in a workshop specially equipped for servicing units with flammable refrigerants.
- ◆ Ensure sufficient ventilation at the repair place.
- ◆ Be aware that malfunction of the equipment may be caused by refrigerant loss and a refrigerant leak is possible.
- ◆ Discharge capacitors in a way that won't cause any spark. The standard procedure to short circuit the capacitor terminals usually creates sparks.
- ◆ Reassemble sealed enclosures accurately. If seals are worn, replace them.
- ◆ Check safety equipment before putting into service.

### Repair

- ◆ Portable equipment shall be repaired outside or in a workshop specially equipped for servicing units with flammable refrigerants.
- ◆ Ensure sufficient ventilation at the repair place.
- ◆ Be aware that malfunction of the equipment may be caused by refrigerant loss and a refrigerant leak is possible.
- ◆ Discharge capacitors in a way that won't cause any spark.
- ◆ When brazing is required, the following procedures shall be carried out in the right order:
  - ◆ Remove the refrigerant. If the recovery is not required by national regulations, drain the refrigerant to the outside. Take care that the drained refrigerant will not cause any danger. In doubt, one person should guard the outlet. Take special care that drained refrigerant will not float back into the building.
  - ◆ Evacuate the refrigerant circuit.
  - ◆ Purge the refrigerant circuit with nitrogen for 5 min.
  - ◆ Evacuate again.
  - ◆ Remove parts to be replaced by cutting, not by flame.
  - ◆ Purge the braze point with nitrogen during the brazing procedure.
  - ◆ Carry out a leak test before charging with refrigerant.
  - ◆ Reassemble sealed enclosures accurately. If seals are worn, replace them.
  - ◆ Check safety equipment before putting into service.

### Decommissioning

- ◆ If the safety is affected when the equipment is put out of service, the refrigerant charge shall be removed before decommissioning.
- ◆ Ensure sufficient ventilation at the equipment location.
- ◆ Be aware that malfunction of the equipment may be caused by refrigerant loss and a refrigerant leak is possible.
- ◆ Discharge capacitors in a way that won't cause any spark.
- ◆ Remove the refrigerant. If the recovery is not required by national regulations, drain the refrigerant to the outside. Take care that the drained refrigerant will not cause any danger. In doubt, one person should guard the outlet.
- ◆ Take special care that drained refrigerant will not float back into the building.
- ◆ Evacuate the refrigerant circuit.
- ◆ Purge the refrigerant circuit with nitrogen for 5 min.
- ◆ Evacuate again.
- ◆ Fill with nitrogen up to atmospheric pressure.
- ◆ Put a label on the equipment that the refrigerant is removed.

### Disposal

- ◆ Ensure sufficient ventilation at the working place.
- ◆ Remove the refrigerant. If the recovery is not required by national regulations, drain the refrigerant to the outside. Take care that the drained refrigerant will not cause any danger. In doubt, one person should guard the outlet.
- ◆ Take special care that drained refrigerant will not float back into the building.
- ◆ Evacuate the refrigerant circuit.
- ◆ Purge the refrigerant circuit with nitrogen for 5 min.
- ◆ Evacuate again.
- ◆ Cut out the compressor and drain the oil.

- ◆ Transportation, marking and storage for units that employ flammable refrigerants

## DECLARATION OF CONFORMITY



Sea&Mew Accounting Ltd,  
Electric Avenue Vision 25, London, Enfield EN3 7GD,  
E-mail: info@seamew.net



This product is conform to the following European Directives:

2014 / 30 / EU (EMC)  
2014 / 35 / EU (LVD)  
2011 / 65 / EU (RoHS)



