

ASSEMBLY INSTRUCTIONS

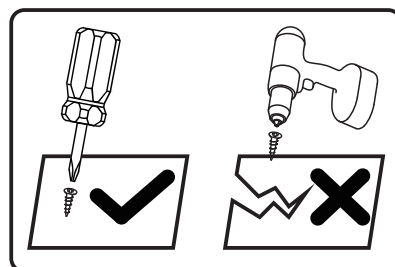
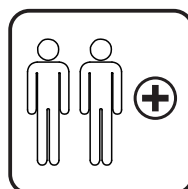
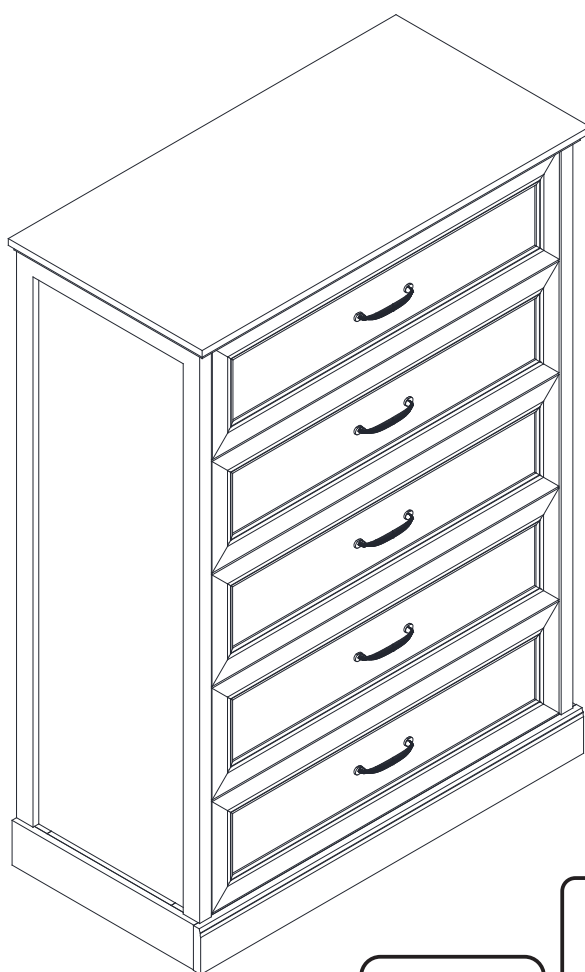

Tools Recommended

IMPORTANT NOTICE

-This product contains small components, please ensure that they are kept away from small children.

-THIS INSTRUCTIONS CONTAINS IMPORTANT SAFETY INFORMATION.
PLEASE READ BEFORE ASSEMBLY AND KEEP FOR FUTURE REFERENCE.

-Read each step carefully. It is very important that each step of instruction is performed in the correct order. If these steps are not followed in sequence, assembly difficulties will occur.

-Make sure all parts are included. Most parts are labelled or stamped on the raw edge.

-Work in spacious area, preferably on a carpet, near the place the unit will be used.

-Do not use power tools to assemble your furniture. Power tools may strip or damage the parts.

-Move your new furniture carefully, with two people lift and carry the unit to it's new location.



-Never push, drag or pull your furniture (especially on carpet)



PLEASE DO NOT RETURN PRODUCT TO US IMMEDIATELY

If a part is missing or damaged, email our customer service.
We will gladly ship your replacement parts FREE of charge.

For Prompt, reliable service, please have your assemble instruction ready

|  WARNING | |
|--|--|
|  | Children have died from furniture tipover. To reduce the risk of furniture tipover: <ul style="list-style-type: none">- ALWAYS install Anti-tip device provided.- NEVER put a TV on this product.- NEVER allow children to stand, climb or hang on any drawers, doors, or shelves.- NEVER open more than one drawer at a time.- Place heaviest items in the lowest drawers. |
|  | <p><i>This is a permanent label. Do not remove!</i></p> |

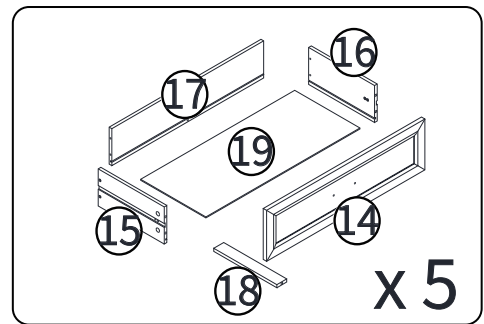
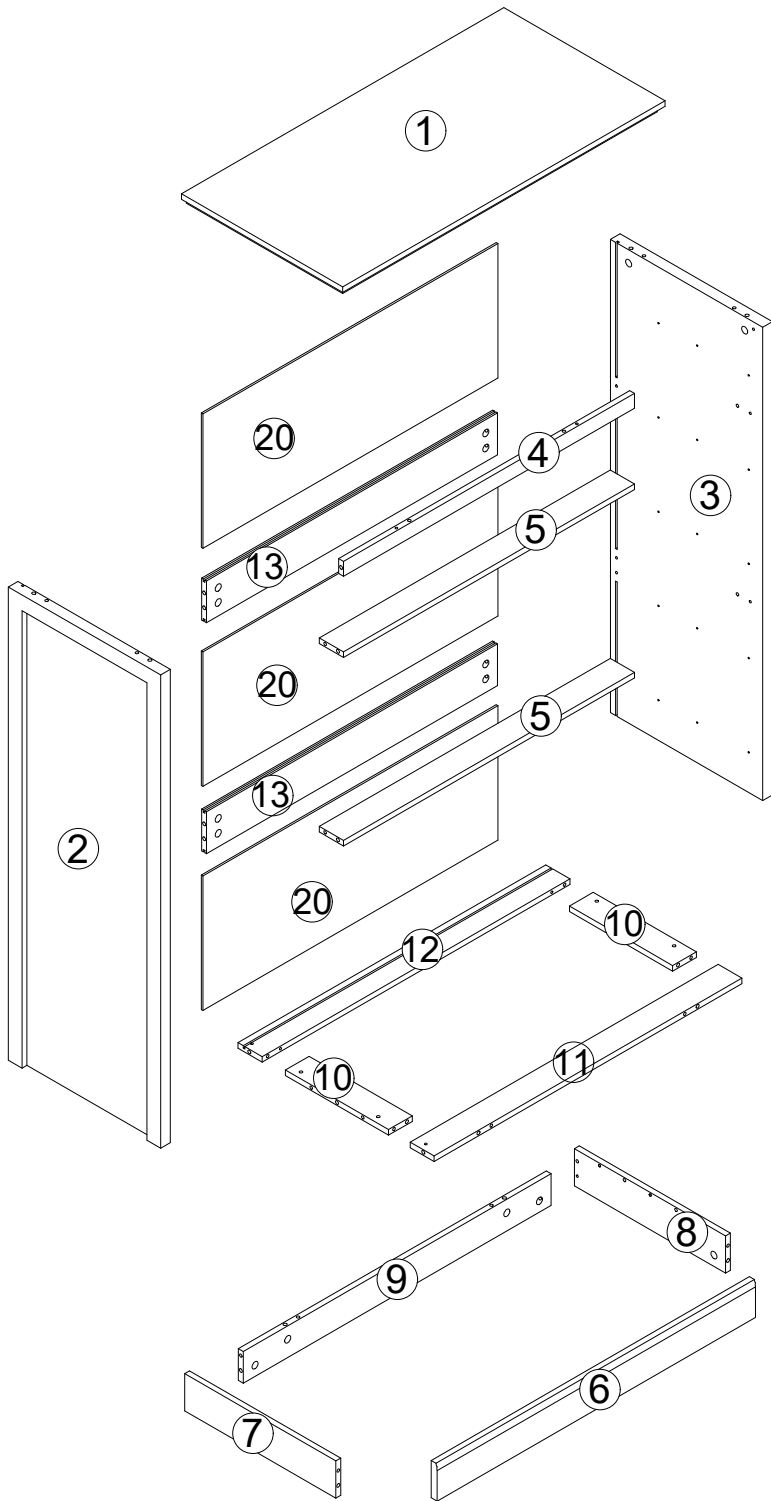

The installation direction should be aligned with the instructions to prevent plate breakage caused by product tipping during installation.

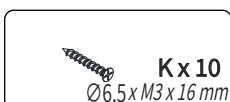
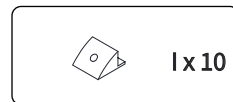
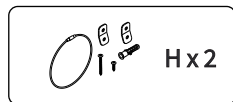
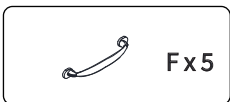
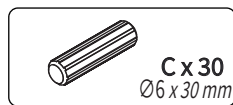

Step 1

Insert quickfit screws(A) into corresponding holes in part ② as shown.
Fix left outer drawer runner(J) parts ② using screws (E),as shown.

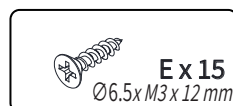
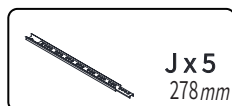
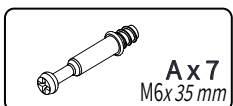
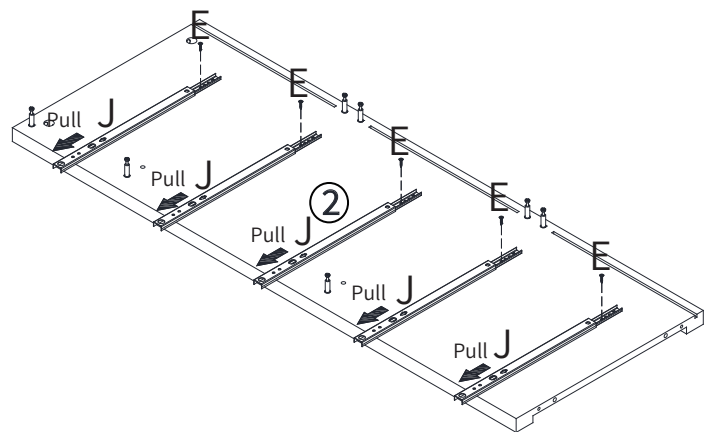
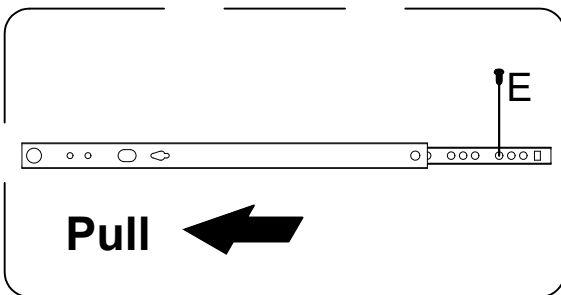
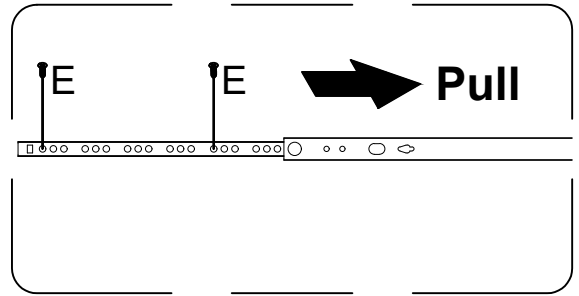
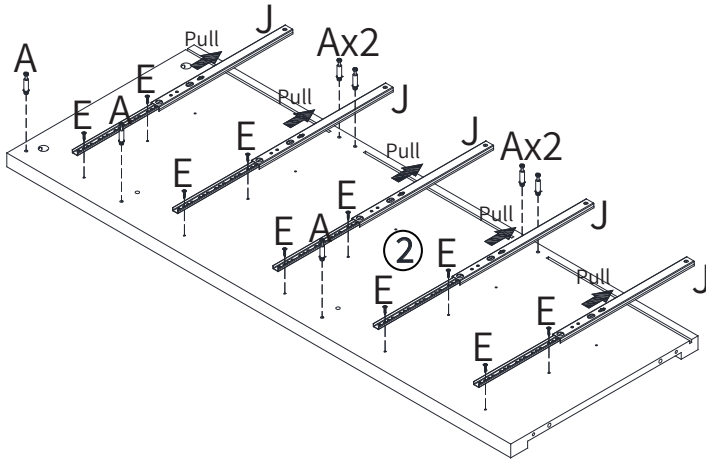

Step 2

Insert quickfit screws(A) into corresponding holes in part ③ as shown.
 Fix left outer drawer runner(J) parts ③ using screws (E),as shown.

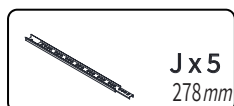
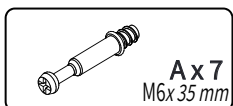
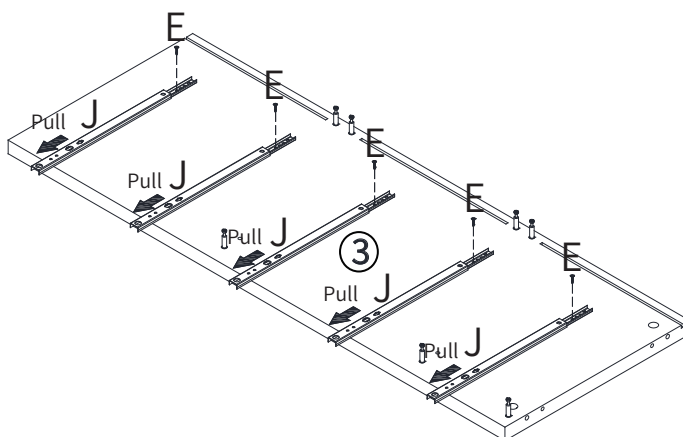
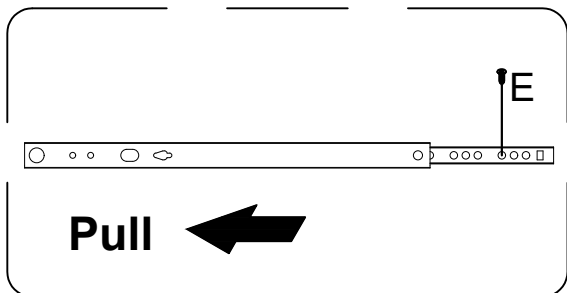
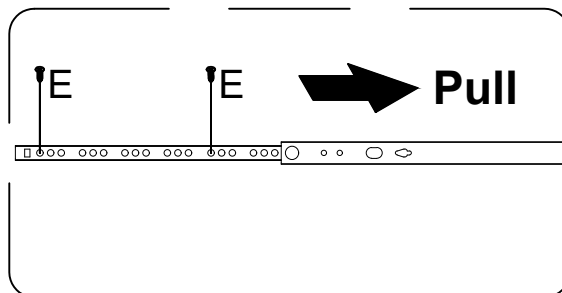
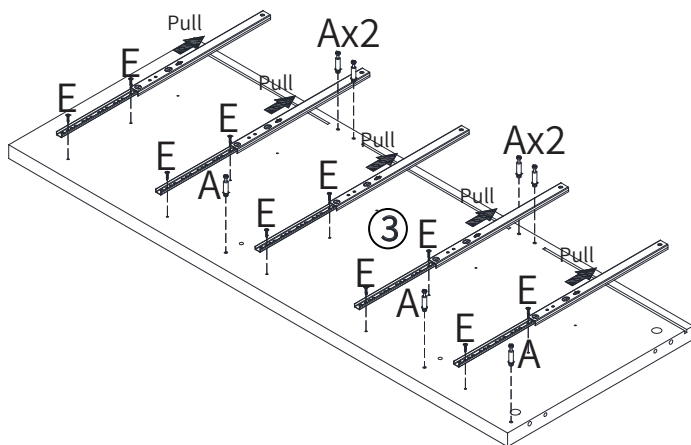

Step 3

Insert quickfit screws(A) into corresponding holes in part ① as shown.

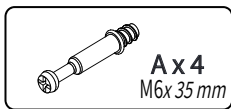
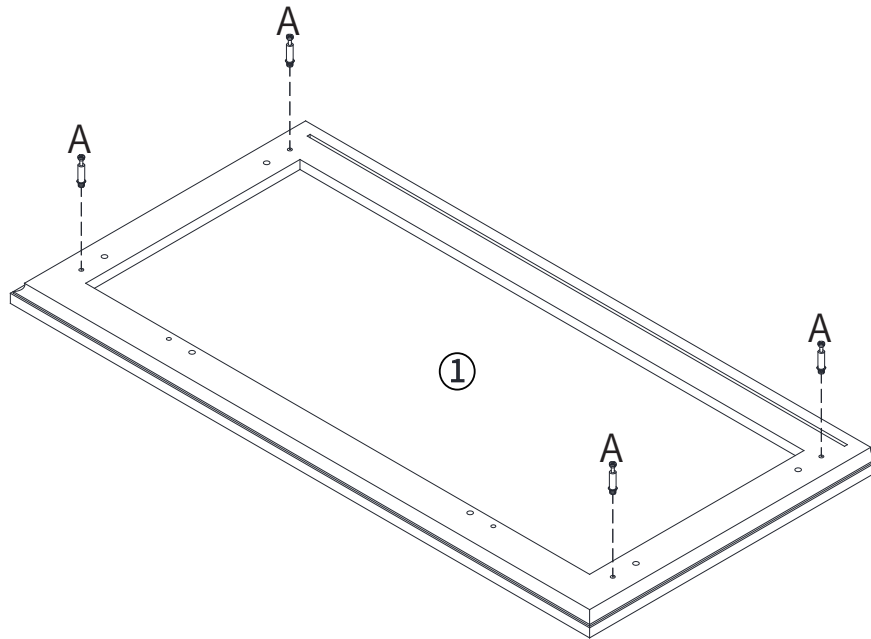

Step 4

As shown in the figure, first put the cork (C) into part ②

Then connect part ② to ④, ⑤, ⑬.

Finally, place the eccentric (B) in the pre-drilled hole and tighten it with a screwdriver

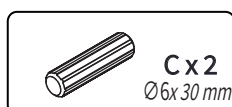
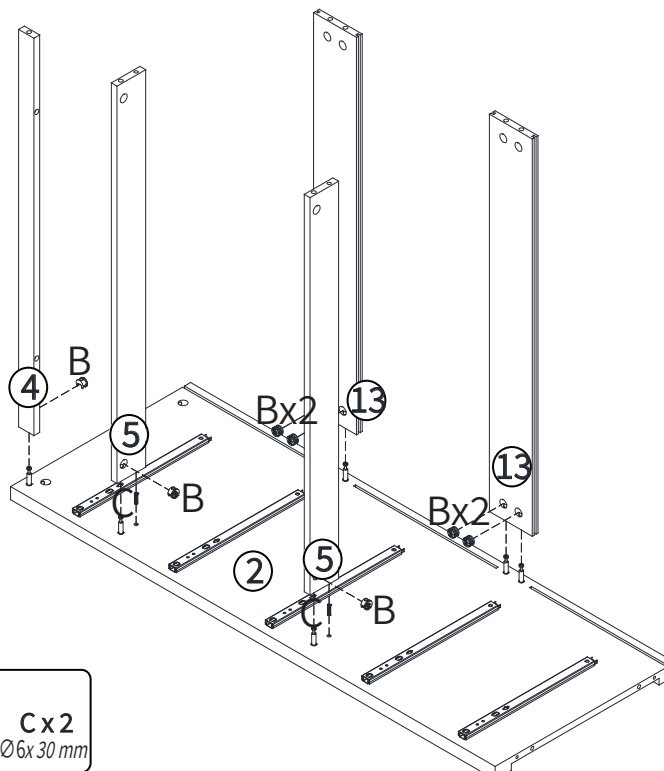
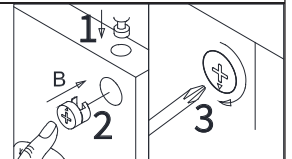

Step 5

Insert the part ⑳ into the backplate groove as shown in the figure

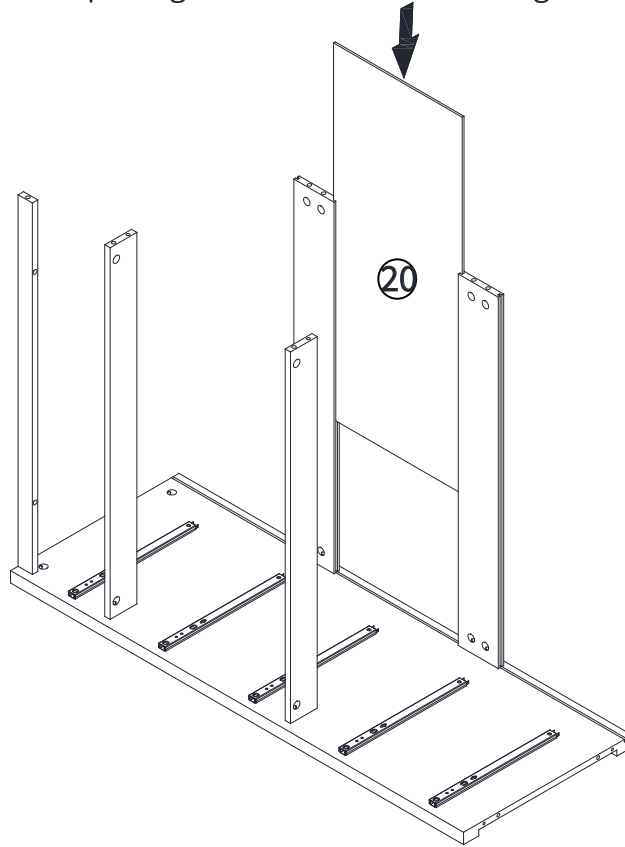

Step 6

As shown in the figure, first put the cork (C) into part ③

Then connect part ③ to ④, ⑤, ⑬.

Finally, place the eccentric (B) in the pre-drilled hole and tighten it with a screwdriver

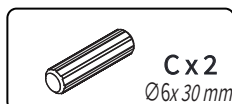
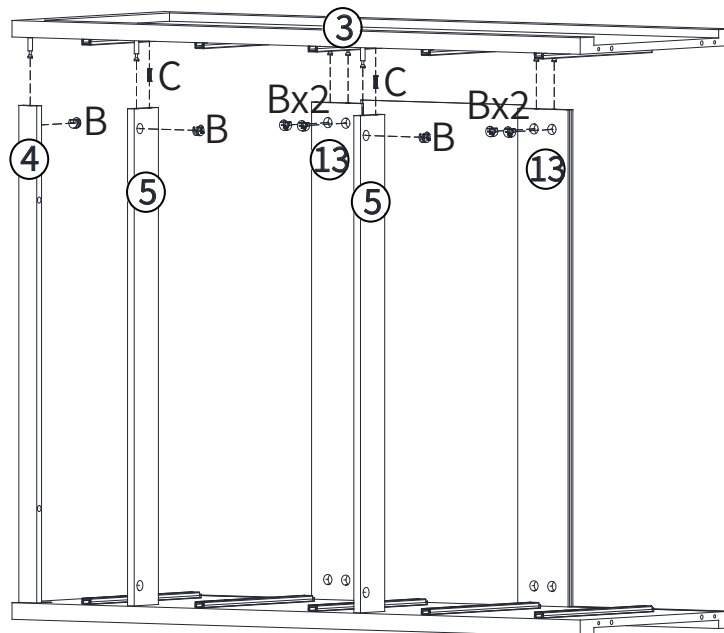
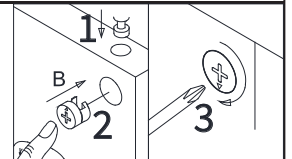

Step 7

Insert the part ⑳ into the backplate groove as shown in the figure

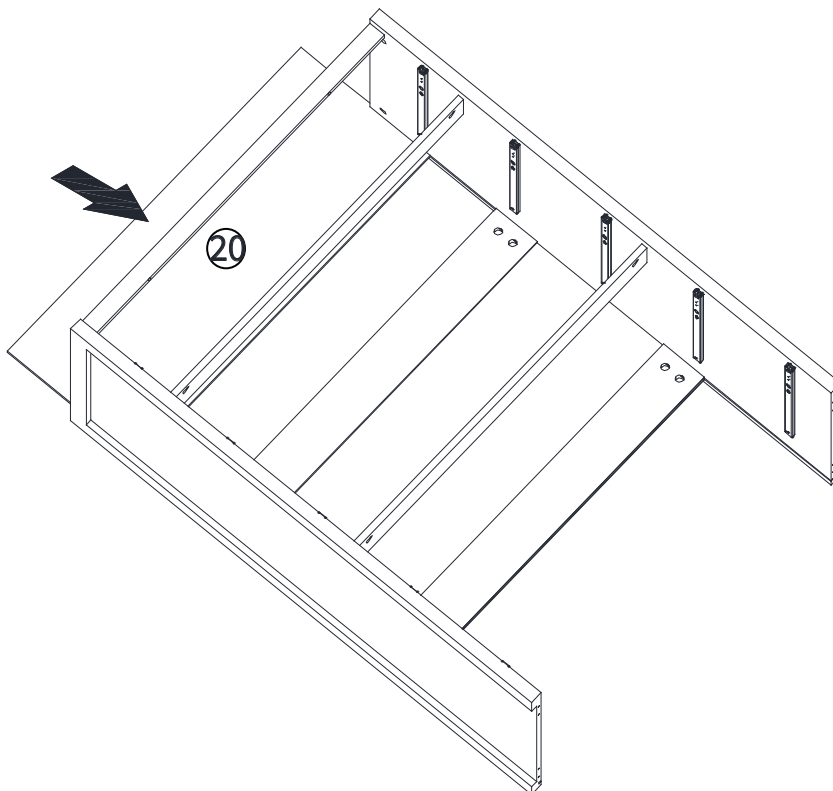

Step 8

As shown in the figure, first put the cork (C) into part ②, ③, ④
Then connect part ① to ②, ③, ④.
place the eccentric (B) in the pre-drilled hole
and tighten it with a screwdriver
Finally, use screws (D) to connect
parts ① to ④.

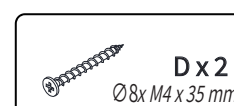
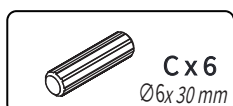
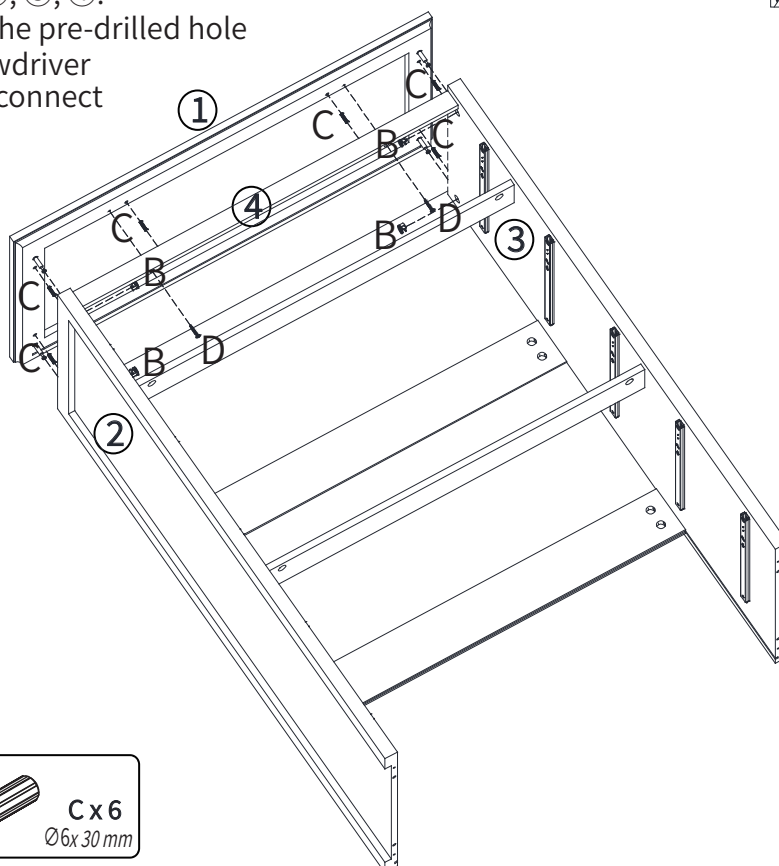
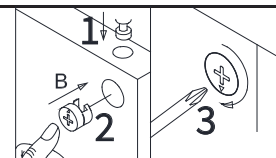

Step 9

Insert the part ⑳ into the backplate groove as shown in the figure

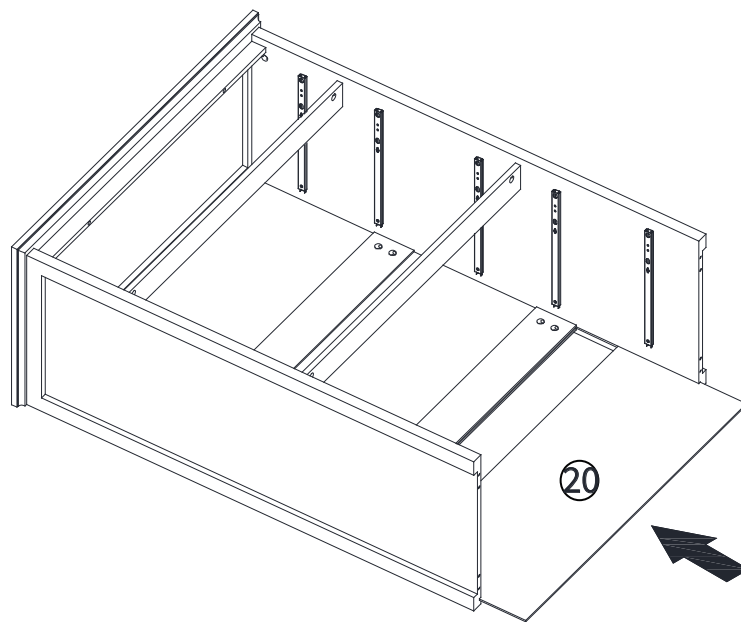

Step 10

Insert quickfit screws(A) into corresponding holes in part ⑥ and ⑦ and ⑧ as shown.

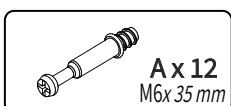
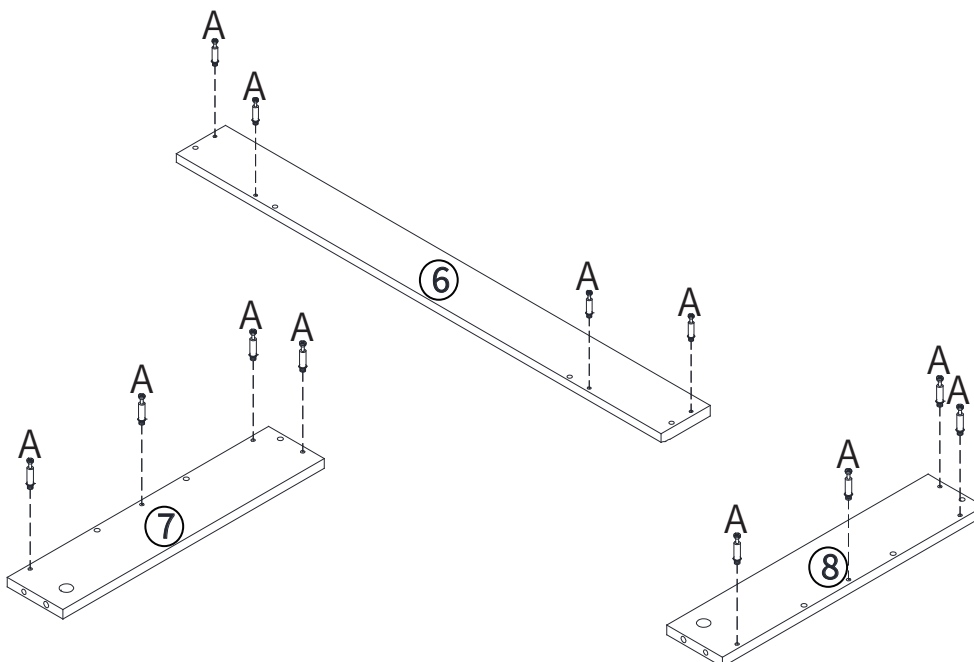

Step 11

Insert quickfit screws(A) into corresponding holes in part ⑪ and ⑫ as shown.

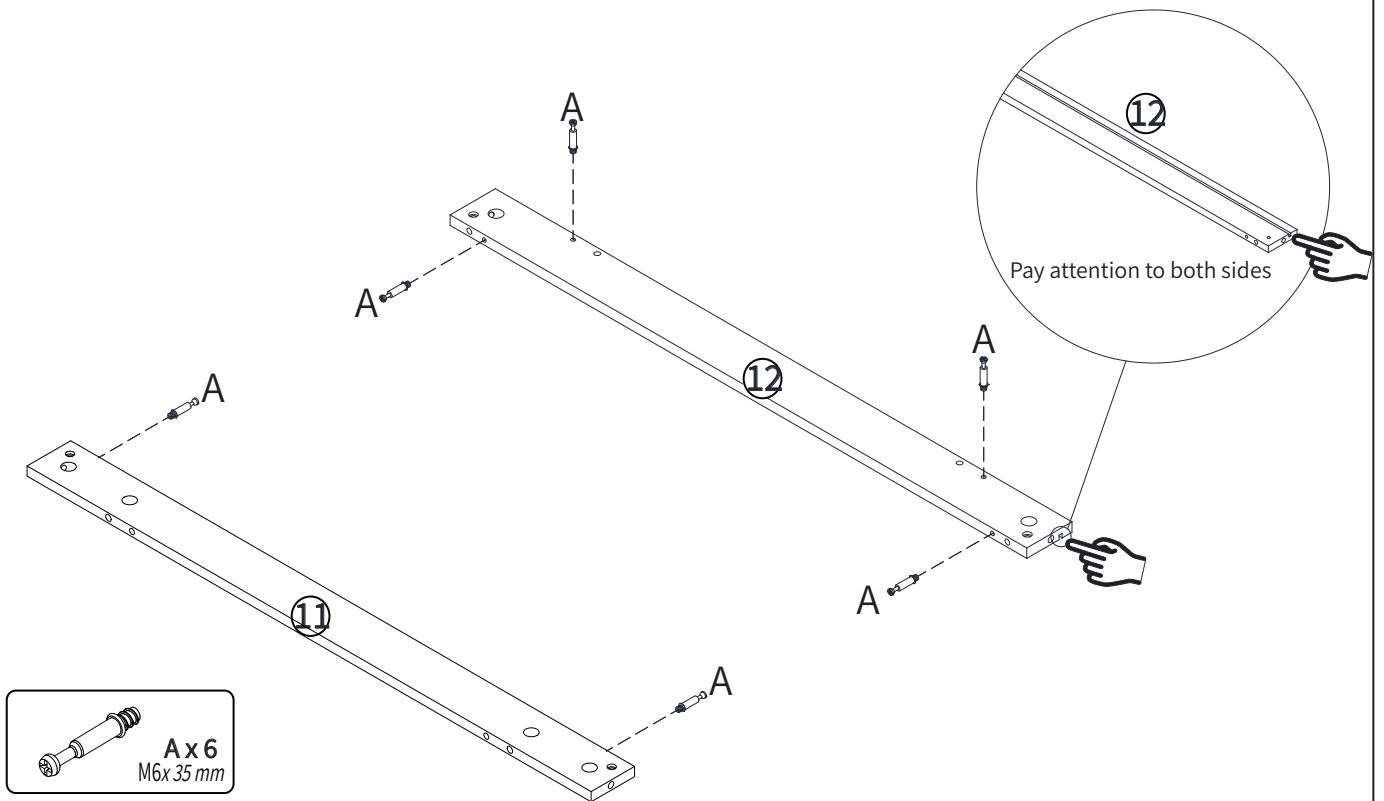

Step 12

As shown in the figure, first put the cork (C) into the two Parts ⑩, and then connect part ⑩ and parts ⑪ and ⑫. Finally, place the eccentric (B) in the pre-drilled hole and tighten it with a screwdriver.

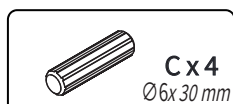
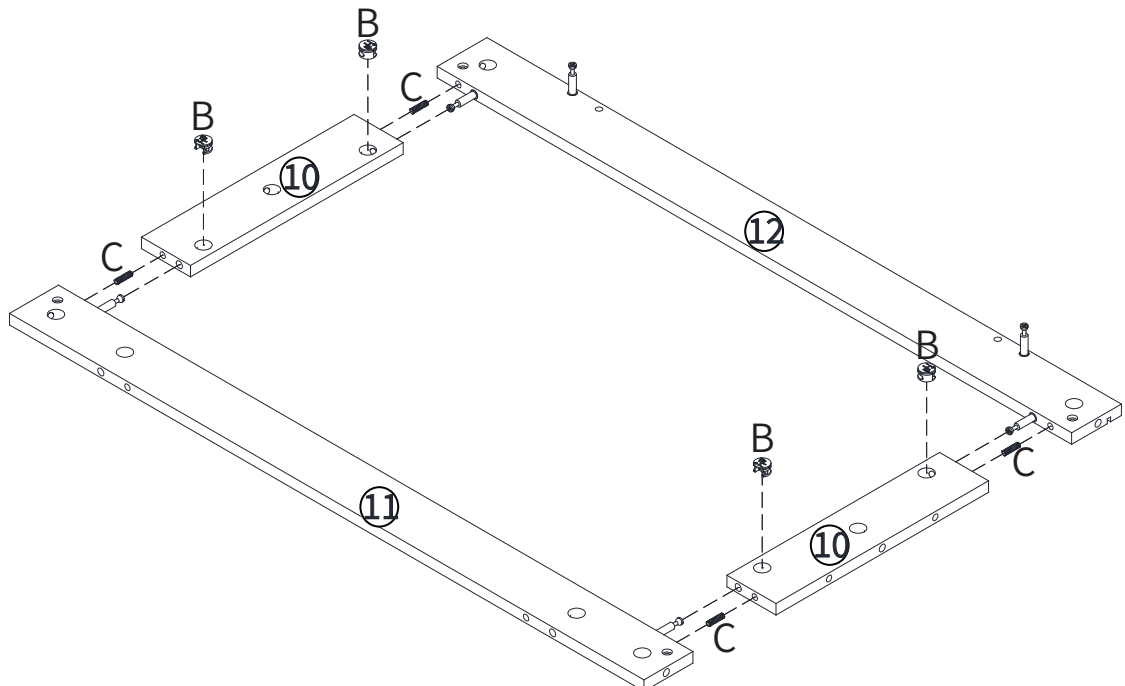
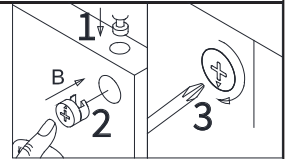

Step 13

As shown in the figure, first put the cork (C) into part ⑫

Then connect part ⑨ and ⑫.

Finally, place the eccentric (B) in the pre-drilled hole and tighten it with a screwdriver

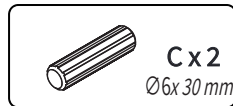
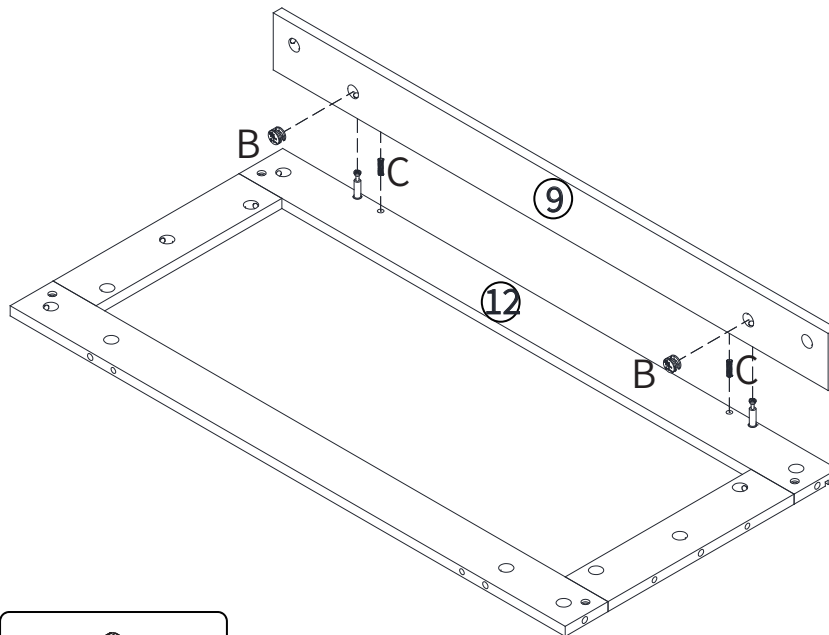
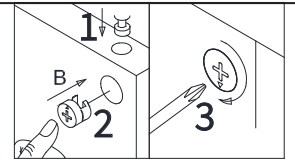

Step 14

As shown in the figure, first put the cork (C) into part ⑦, ⑧

Then connect parts ⑦, ⑧ and ⑨, ⑩, ⑪.

Finally, place the eccentric (B) in the pre-drilled hole and tighten it with a screwdriver

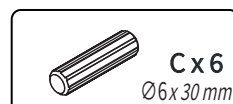
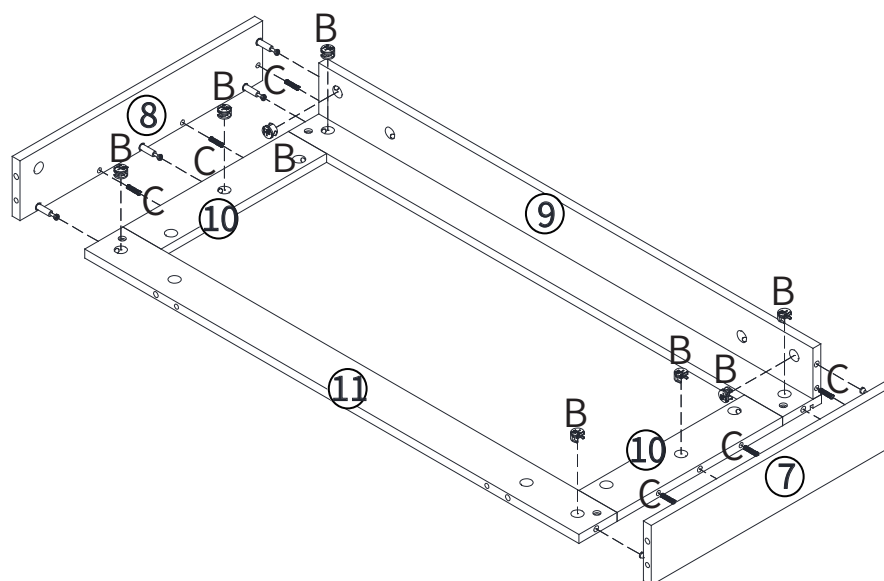
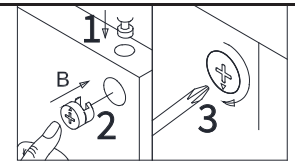

Step 15

As shown in the figure, first put the cork (C) into part ⑦, ⑧, ⑪

Then connect part ⑥ and ⑦, ⑧, ⑪.

Finally, place the eccentric (B) wheel in the pre-drilled hole and tighten it with a screwdriver

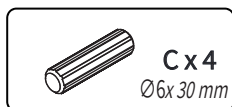
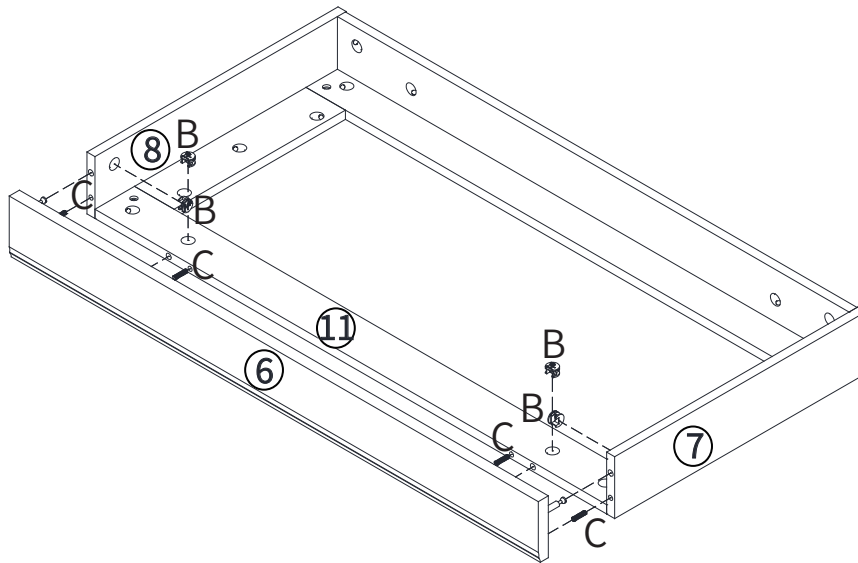
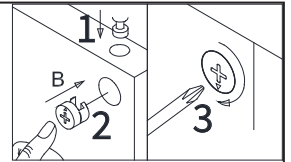

Step 16

As shown in the figure, First put the cork (C) in part ② and ③

Then use screws (D) to connect parts ⑥ and ②, ③

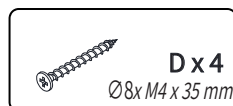
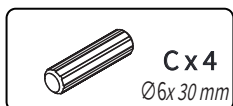
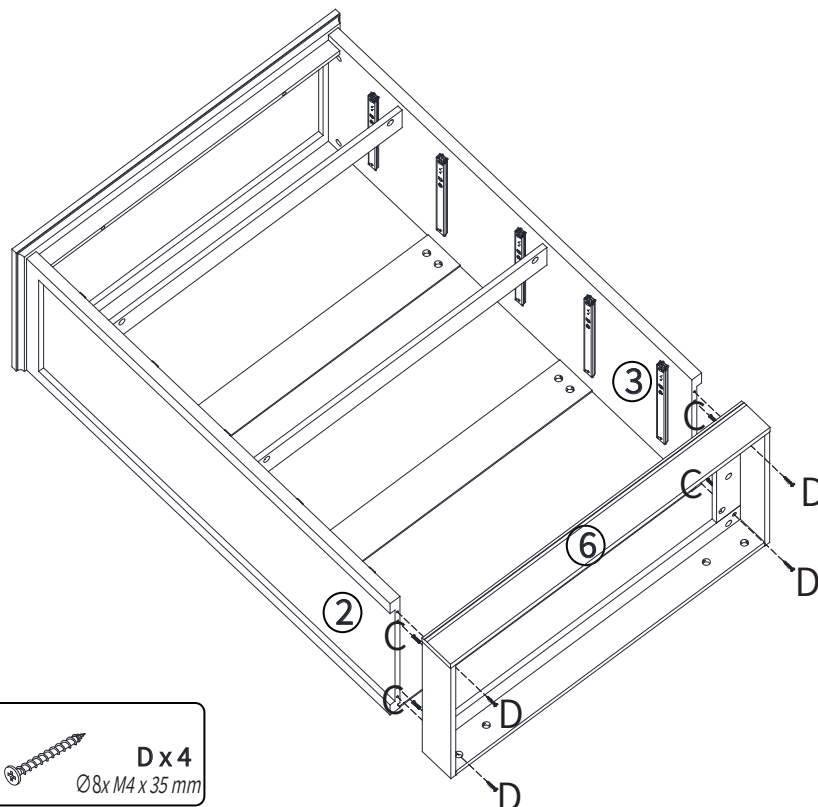

Step 17

Insert quickfit screws(A) into corresponding holes in part ⑭ as shown.

As shown in the figure, the plate ⑮ ⑯ ⑰ ⑱ is connected and fixed with screw (D).

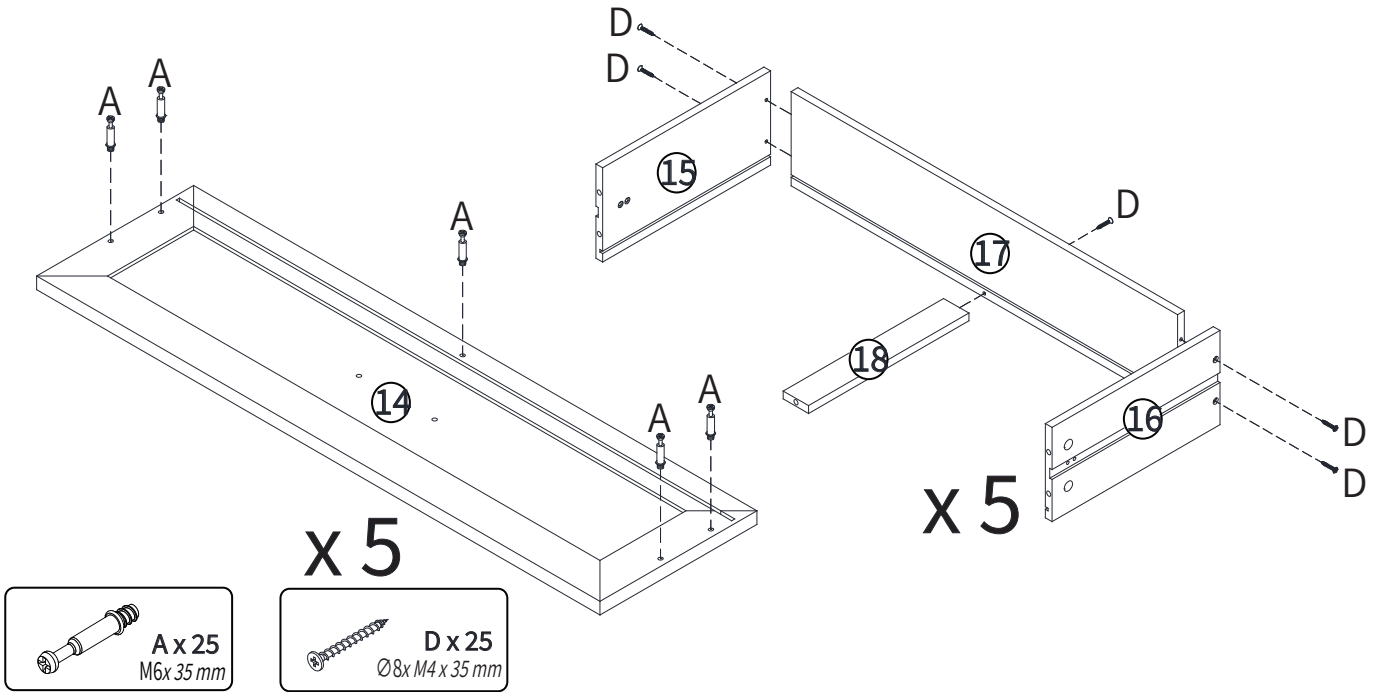

Step 18

As shown in the figure, the plate piece ⑲ is inserted into the drawer side plate groove. Then connect part ⑭ to ⑮, ⑯, ⑱.

Finally, place the eccentric(B) wheel in the pre-drilled hole and tighten it with a screwdriver.

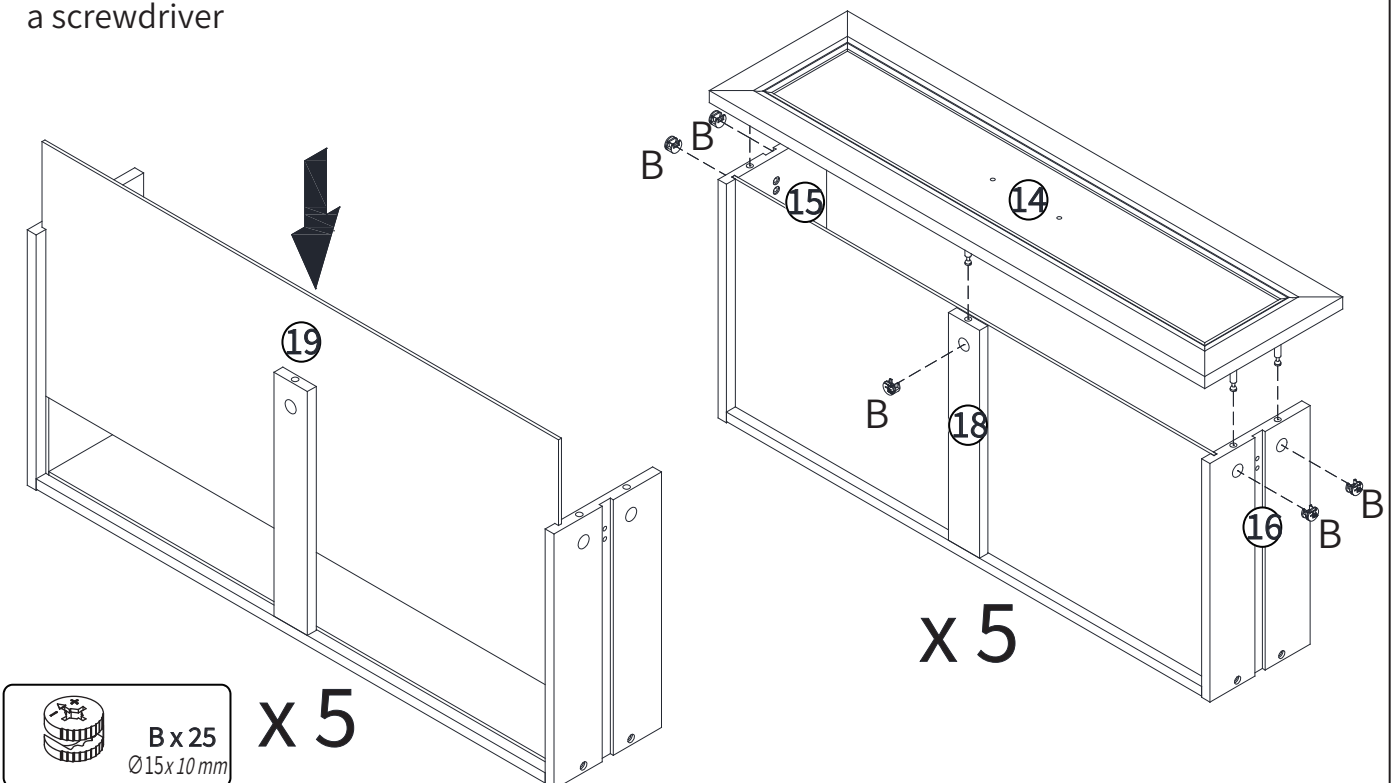
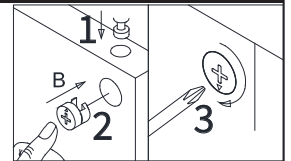

Step 19

As shown in the figure, fix the handle (F) with screw (G) on part ⑭

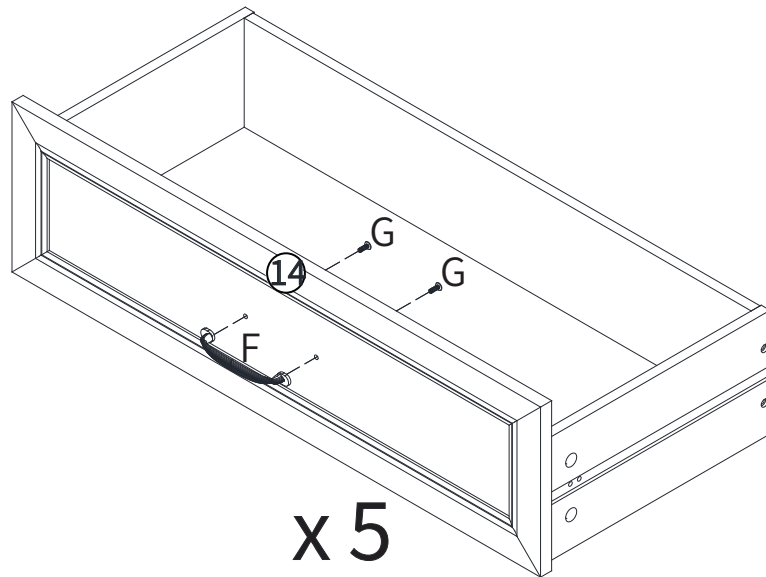

Step 20

As shown in the figure, slide the slide rail in the direction of the arrow to the farthest position. As shown in the picture, after confirming that the sliding rails on both sides are close to the slot at the same time, push the drawer inward.

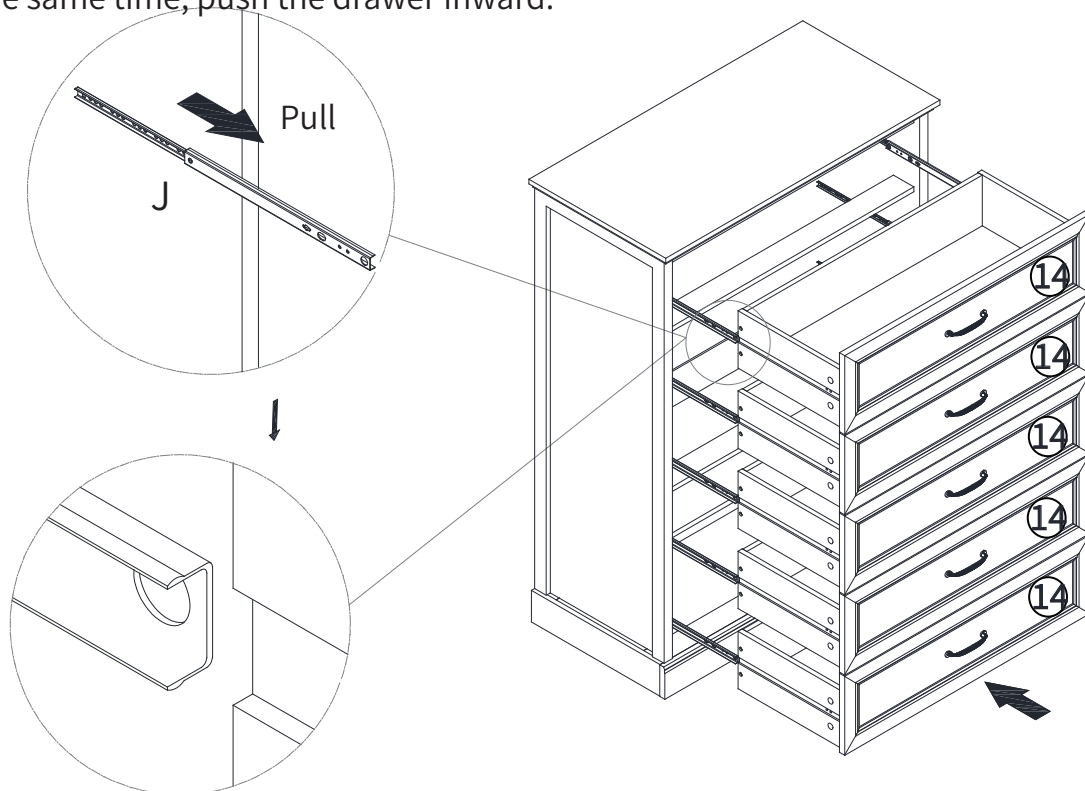

Step 21

Align the panel holes with the guide rail holes and secure them with screws (G).
The installation position is as shown below.

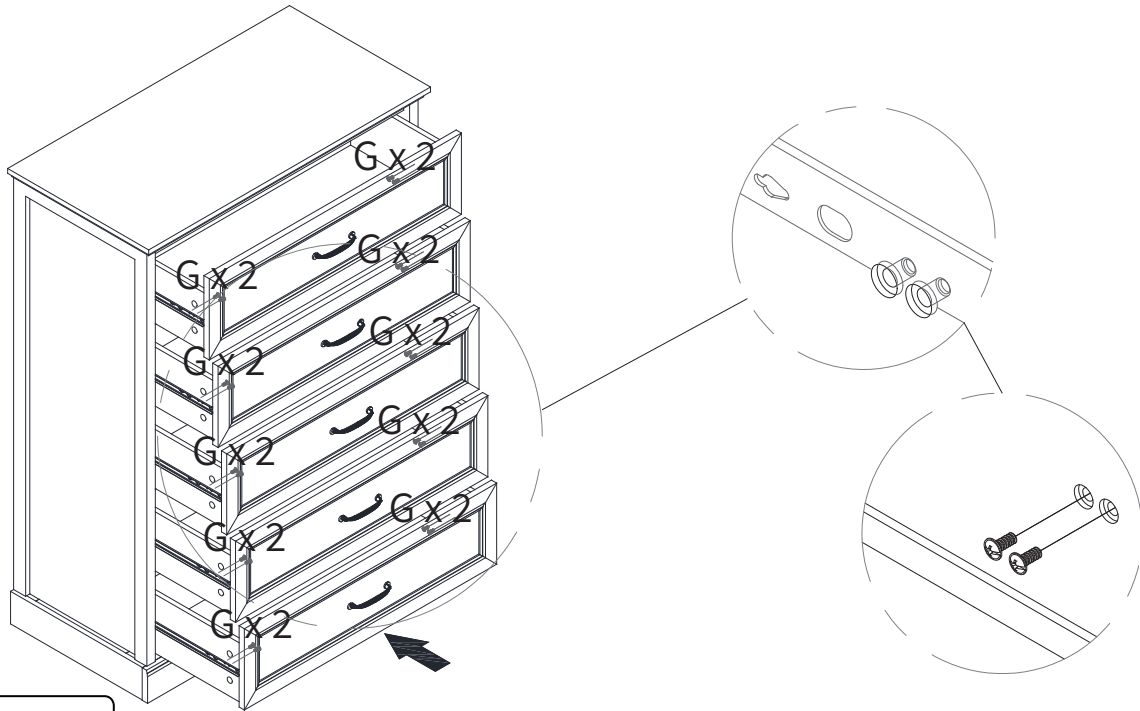

Step 22

As shown in the picture, using screws (K), attach the back plate brackets (I) to the back of the product.
Install the anti-tip straps (H) on both sides of the part ①,
securing them to prevent tipping hazards

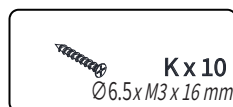
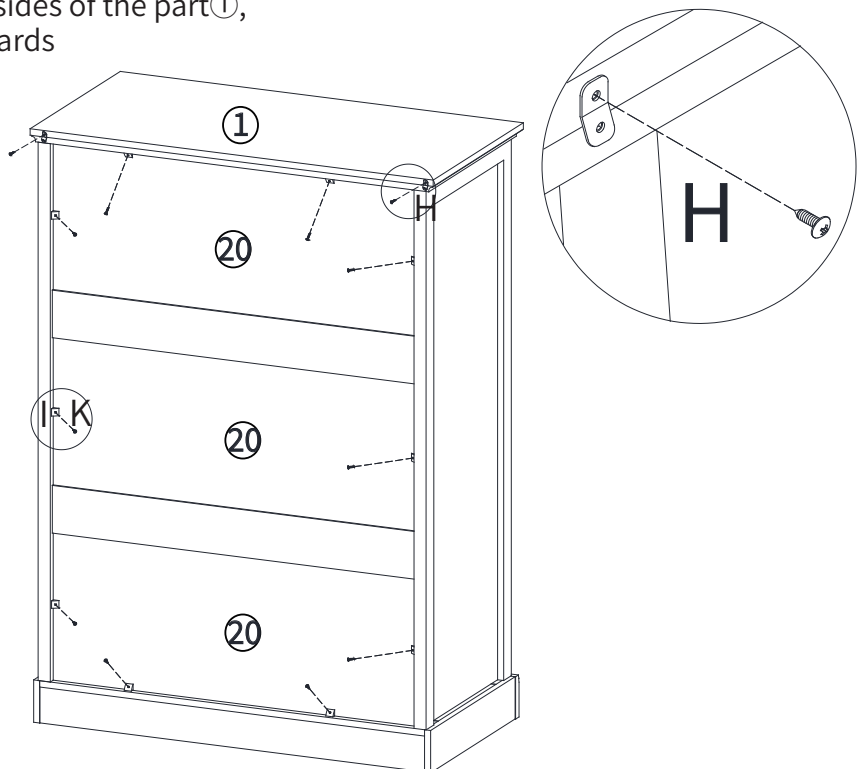
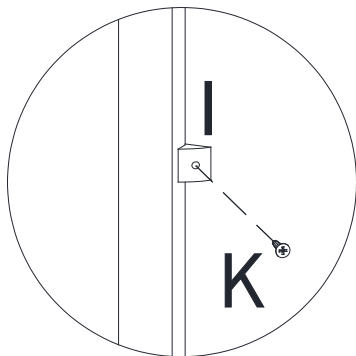
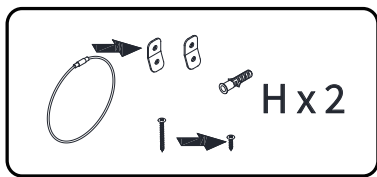

Step 23

Assembling Accessories (H) as shown in the figure.

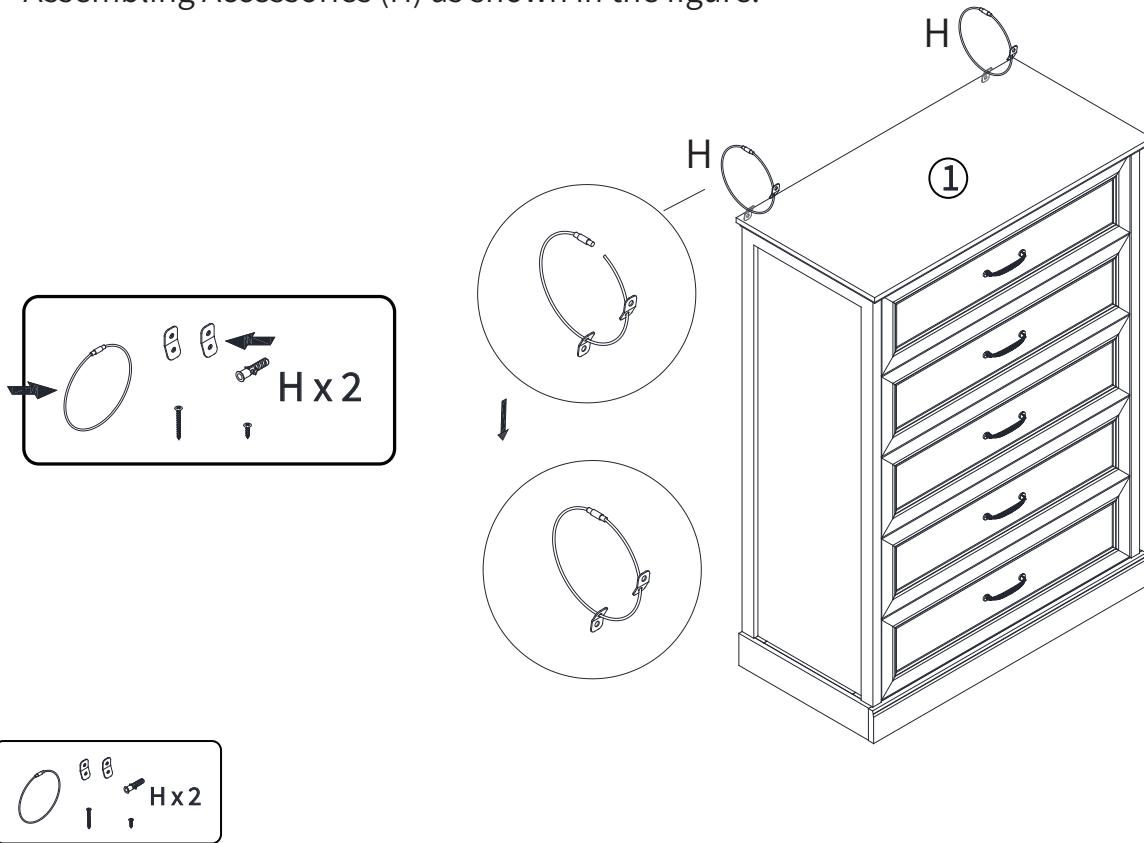

Step 24

Install the anti-tilt fitting (H) as shown.

