

Assembly Instructions

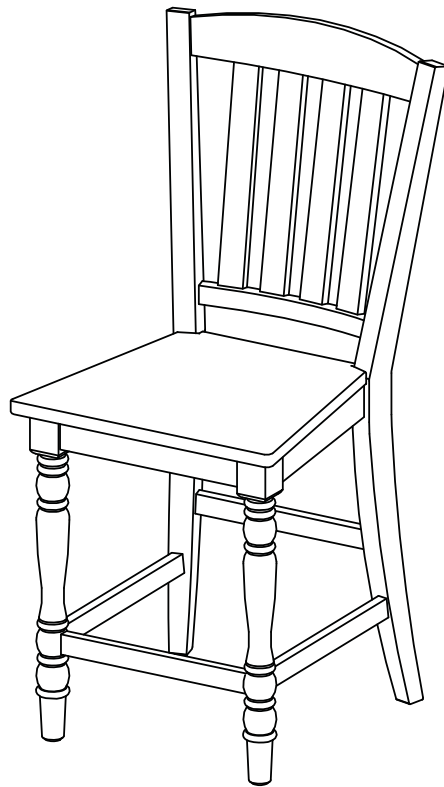

ASSEMBLY RATING

The Assembly Rating is a 5-point system that shows the degree of effort needed in assembling a specific product (with 1 being easy and 5 being difficult). For some products, two persons are recommended.

EASY



DIFFICULT

Tools Required For Assembly:

Allen Wrench

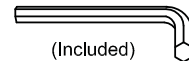

(Included)

Wrench



(Included)

Phillips Screwdriver



(Not Included)

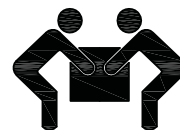

2 PERSONS RECOMMENDED

ASSEMBLY & CARE ADVICE

FOR YOUR FURNITURE TO LAST, CORRECT ASSEMBLY AND PROPER MAINTENANCE ARE NECESSARY. PLEASE FOLLOW THE INFORMATION PROVIDED BELOW TO FULLY ENJOY YOUR FURNITURE.

BASIC ASSEMBLY TECHNIQUES

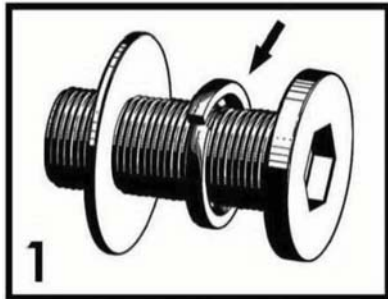

1 When lock or spring washer is used in an assembly, please make sure the lock or spring washer is placed between the larger flat washer and the head of the screw or bolt.



2 Position each part correctly and insert screws or bolts into their respective holes by hand tighten or using the proper hand tool. Only tighten when step is completed or when instructed to do so.

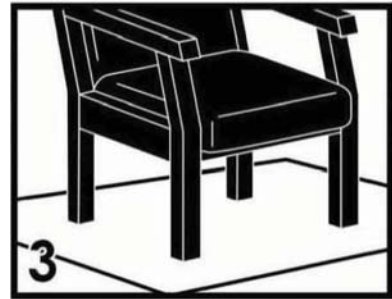

3 Use cardboard or carpet area when assembling furniture to prevent scratches. Make sure the furniture rests on a flat and level surface with each leg evenly touching the floor.

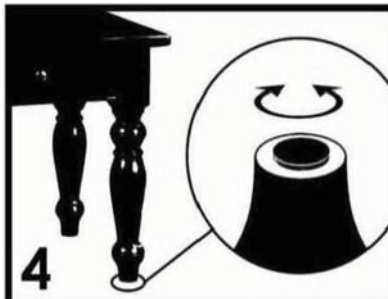

4 Some furniture comes with height adjustment knobs underneath each leg. To lower or to raise each leg, you need to turn clockwise or counterclockwise, respectively.

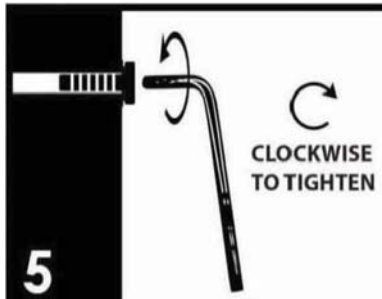

5 Make sure all parts are properly aligned, then use the appropriate hand tool to completely tighten the bolts or screws. Do not use power tools and do not overtighten.

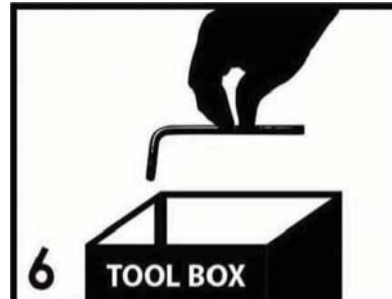

6 Save the instructions and store the Allen wrench or any supplied tool for later maintenance. After two weeks, check and tighten any loose hardware and repeat again every six months thereafter.

IT IS THE USER'S RESPONSIBILITY TO MAINTAIN THE FURNITURE. THE HARDWARE MAY LOOSEN OVER TIME AND MAY CAUSE THE FURNITURE TO BE WOBBLY AND UNABLE TO SUPPORT ITS INTENDED WEIGHT CAPACITY. THIS MAY LEAD TO COLLAPSE AND MAY CAUSE SERIOUS INJURY.

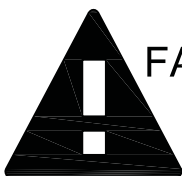





FAILURE TO FOLLOW THE GUIDELINES ABOVE MAY RESULT IN INJURY AND/OR PROPERTY DAMAGE.



Before you begin, please read Page 2 of "Assembly and Care Advice".

And remember, do not tighten until each step is completed or instructed.





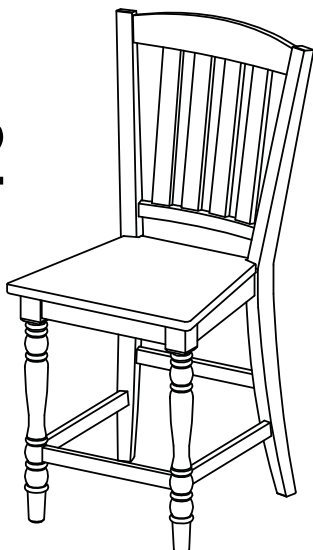

Parts List

-  #1 x 1pc x 2
Backrest
-  #2 x 1pc x 2
Seat
-  #3 x 2pcs x 2
Front Leg(L&R)
-  #4 x 1pc x 2
Front Leg Support
-  #5 x 2pcs x 2
Side Leg Support(L&R)

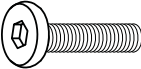
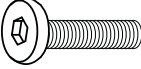
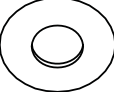
x 2

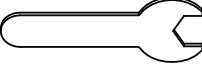
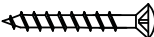

Hardware List

-  #A x 3pcs x 2
Bolt (1/4 x 1-1/2"L)
-  #B x 4pcs x 2
Bolt (1/4 x 3-1/4"L)
-  #C x 7pcs x 2
Flat Washer(Ø1/4")
-  #D x 7pcs x 2
Lock Washer(Ø1/4")
-  #E x 1pc x 2
Allen Wrench M4
-  #F x 4pcs x 2
Hex Nut(Ø5/16")
-  #G x 4pcs x 2
Flat Washer(Ø5/16")
-  #H x 4pcs x 2
Lock Washer(Ø5/16")
-  #I x 1pc x 2
Wrench
-  #K x 6pcs x 2
Screw #8x40mm



#A x 3 pcs
 #C x 3 pcs
 #D x 3 pcs

1. Prepare 3 bolt assemblies by first inserting a lock washer (#D) onto the bolt (#A) then a flat washer (#C) onto that same bolt (#A).

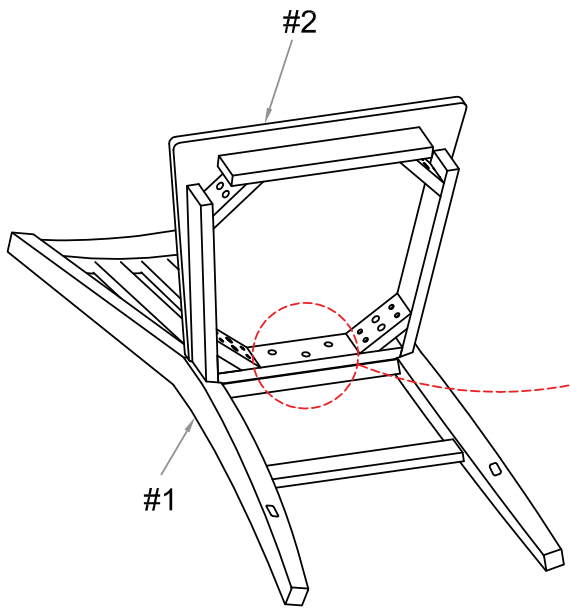
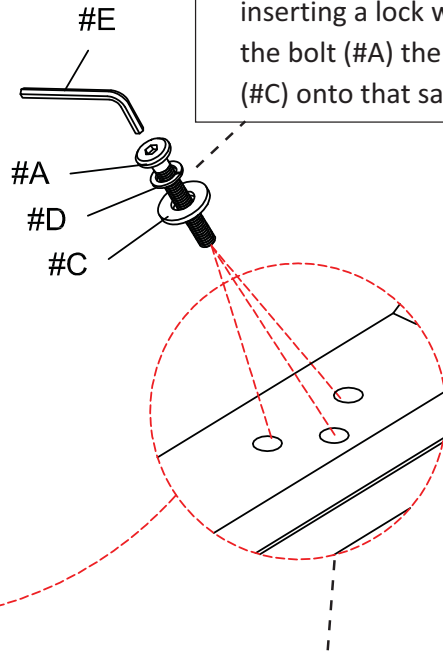

2. Place the backrest (#1) onto a protected surface, then align the seat (#2). Insert the bolt assemblies into the center holes and secure using the Allen wrench (#E).



#B x 4 pcs
 #D x 4 pcs
 #C x 4 pcs

1. Prepare 4 bolt assemblies by first inserting a lock washer (#D) onto the bolt (#B) then a flat washer (#C) onto that same bolt (#B).

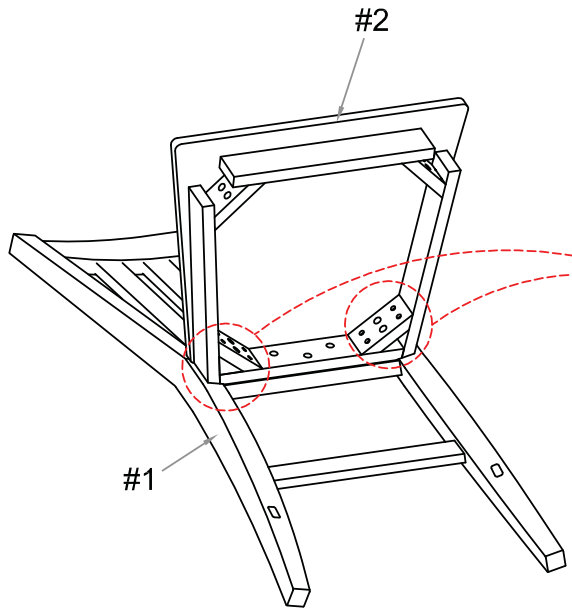
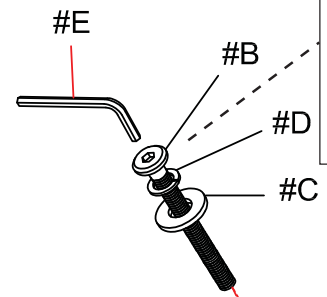

2. Insert 2 bolt assemblies into each back corner of the seat (#2) and secure using the Allen wrench (#E).



1. Insert the threaded ends of the front legs (#3) into the front corners of the seat (#2), make sure to insert the leg supports (#4,5) into the slots as you align the front legs.

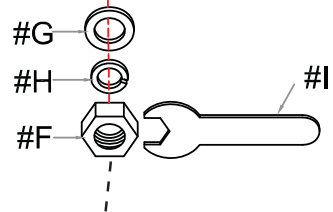
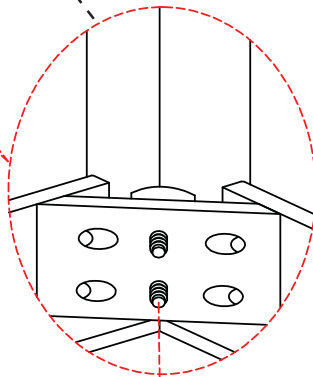
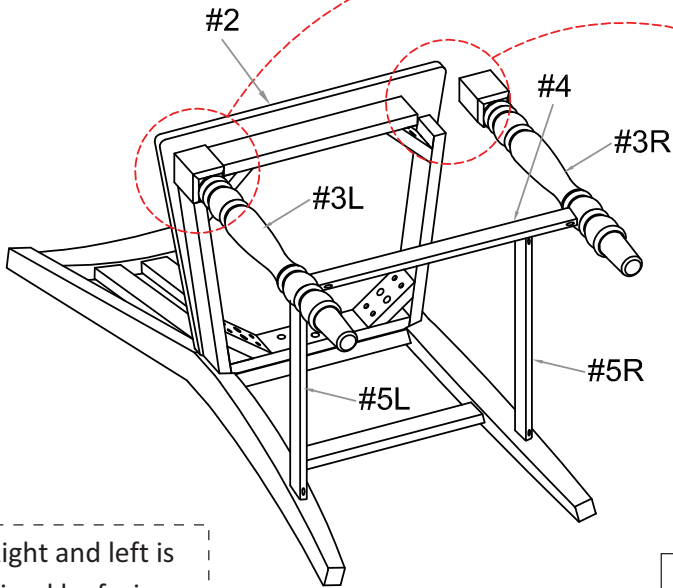

Note: Right and left is determined by facing the front of the chair in its upright position.

2. Apply a flat washer (#G), lock washer (#H), and hex nut (#F) onto each threaded end in that order. Secure using the wrench (#I).



#K x 6 pcs

Insert a wood screw (#K) into each end of the leg supports (#4,5). Secure using the Phillips screwdriver.

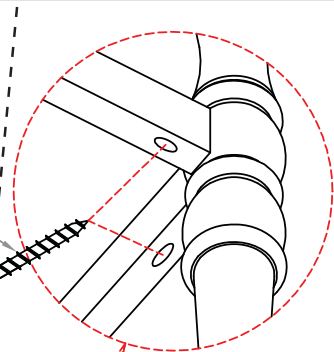
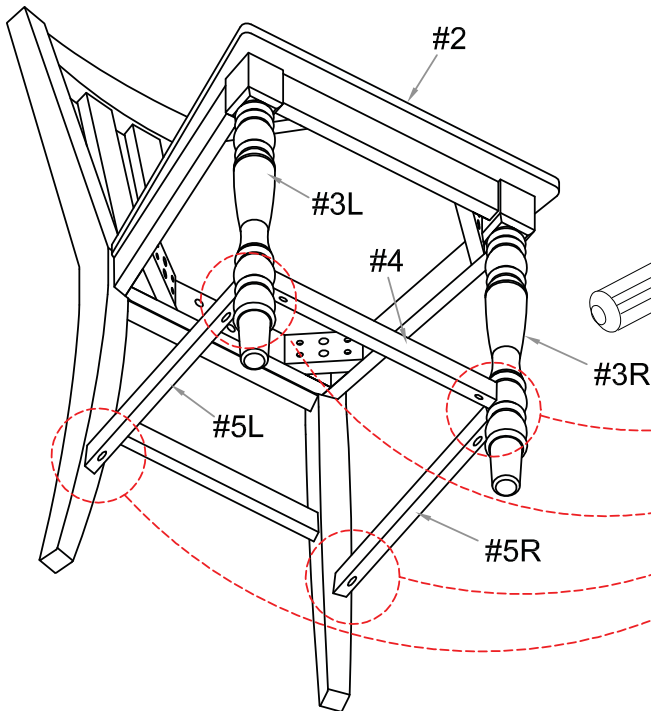

ASSEMBLY IS COMPLETED