

USER'S MANUAL

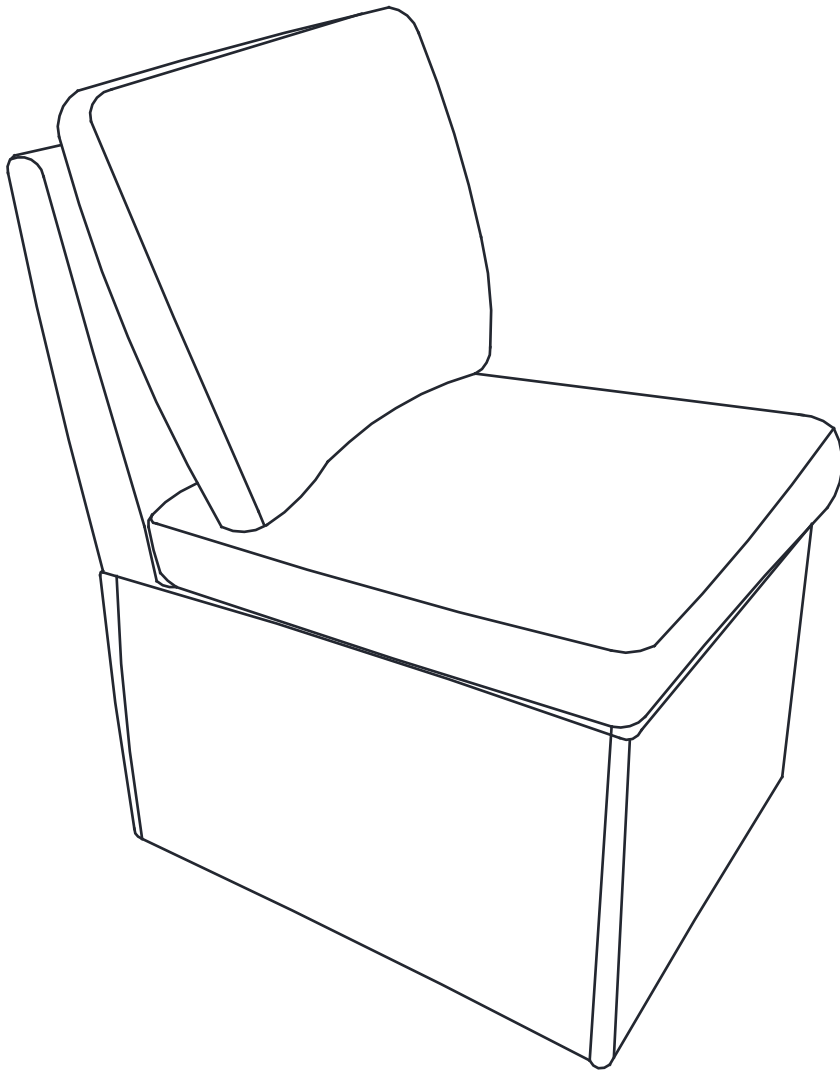

Guide of Manual

- Thanks for your choice. **We will do our best to provide customer service for everyone.**
- Please check to make sure all parts are included as stated when you unpack. If there are parts missing or wrong, please contact us, **we will expeditiously provide reissue accessories, compensation or other services.**
- Instruction should be read carefully. But the manual may not cover every detail of all possible situations and steps. **Please contact us if further information and help are needed. We will respond in a timely manner.**
- **Please be patient that the other items are on the way if you buy more than one product.**

Warning

- It's kindly advised to assemble this product on a carpeted floor to protect it from being scratched.
- Small parts are included. Please keep the product away from children while assembling. Do not let children play or jump on the product. Do not stand on the item or use as a step ladder.
- Please pay attention to the sharp corners during assembly. We recommend the use of gloves to prevent the undesired injury.
- Prior to use, please check to see if there's any loosening screw or part. Make sure that each screw and part is correctly installed and securely fastened.
- It's unnecessary to use electric drill. Please at a low gear if you need.

Care and Maintenance

- Use a soft, clean cloth that will not scratch the surface when dusting.
- There' s no need to use furniture polish. If you need, test it first in an inconspicuous area. Using solvents of any kind on your furniture may damage the finish. Never use water to clean your furniture as it may cause damage to the finish.
- Liquid spills should be removed immediately. Gently blot the spill with a soft clean cloth to avoid rubbing.

Further Advice about the Furniture Care

- It is best to keep your furniture in a climate-controlled environment.
- We recommend to keep furniture from sunlight exposure to avoid possible surface damage.
- Following these important and helpful tips will help retain your furniture's performance even when it ages.
- Periodically (every 90 days) make sure the screws are fully tightened.





Max Weight Capacity

- **350lbs [Do not stand on the item]**

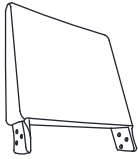
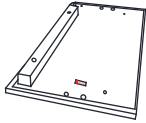
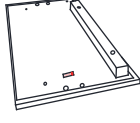
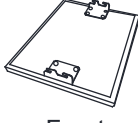
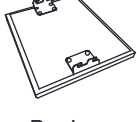
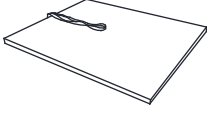
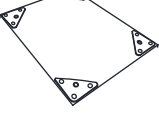

Parts and Hardware List:

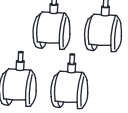
- Make sure all parts and hardware are in the package.
- Do not fully tighten anything until all screws, nuts, washers and bolts are in place.
- "+" in below list indicates that additional pieces are replacement parts.

Parts List

<p>Ax1 backrest</p> 	<p>Bx1 bottom panel</p>  <p>Left</p>	<p>Cx1 bottom panel</p>  <p>Right</p>	<p>Dx1 bottom panel</p>  <p>Front</p>
<p>Ex1 bottom panel</p>  <p>Back</p>	<p>Fx1 seat pad</p> 	<p>Gx1 bottom panel</p> 	<p>Hx1 back cushion</p> 
<p>Ix1 seat cushion</p> 	<p>Jx4 castor</p> 	<p>Mx4 Joint bar</p> 	

Hardware List

<p>Kx9</p>  <p>M6x16mm</p>	<p>Lx7</p>  <p>M6x30mm</p>	<p>Nx1 Wrench</p> 
---	---	--

Tips:

1. Please do not 100% tighten all the bolts until the chair is fully assembled, just 50% is OK, make it has space to adjust the chair.
2. Knead your back & seat cushion like giving your cushion a massage while allowing the air to flow through the foam.
3. Repeatedly tap the sides and front and back to make it rebound better and fluffy.

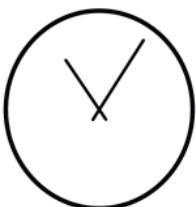

72h

It might takes up to 72 hours.

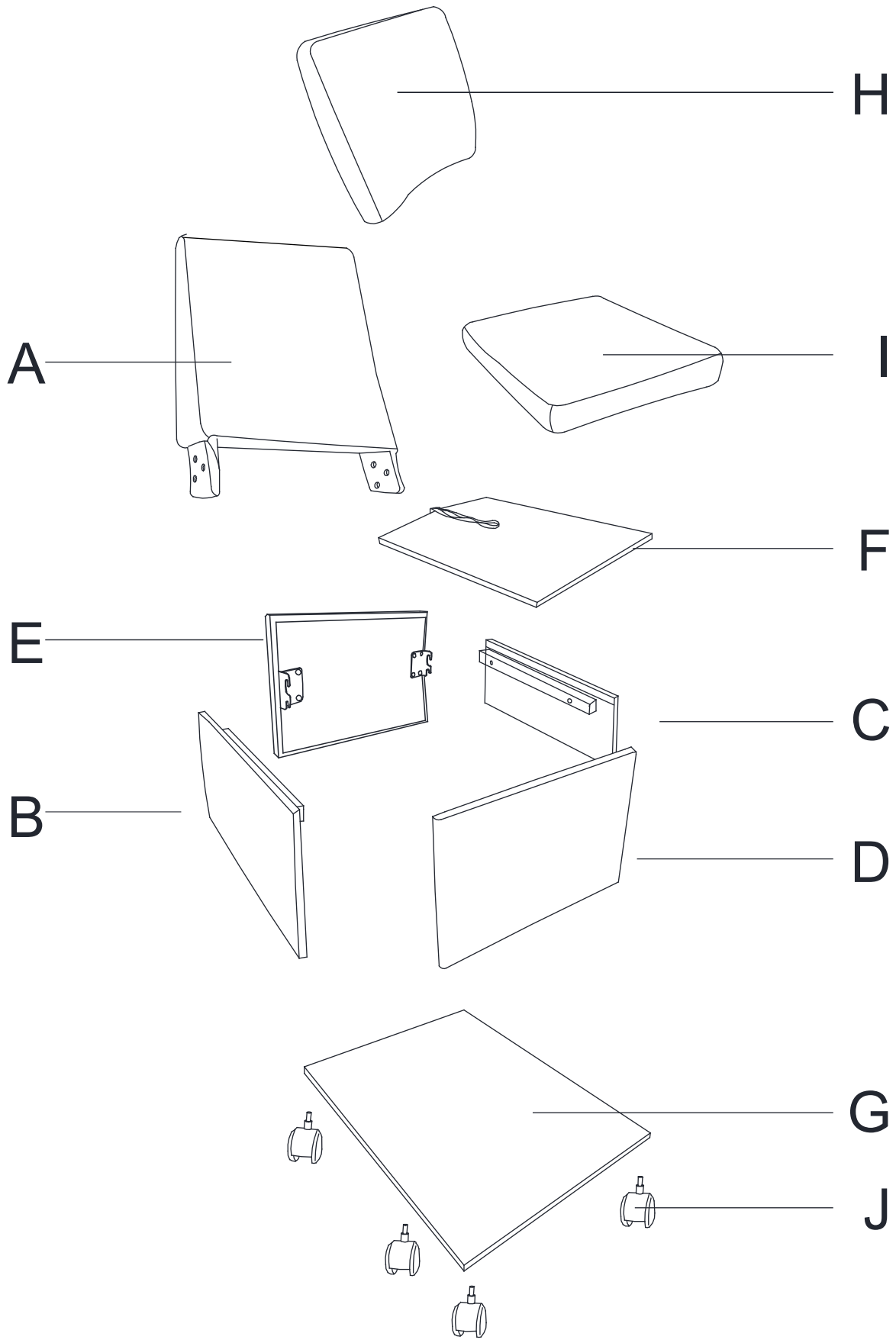

1

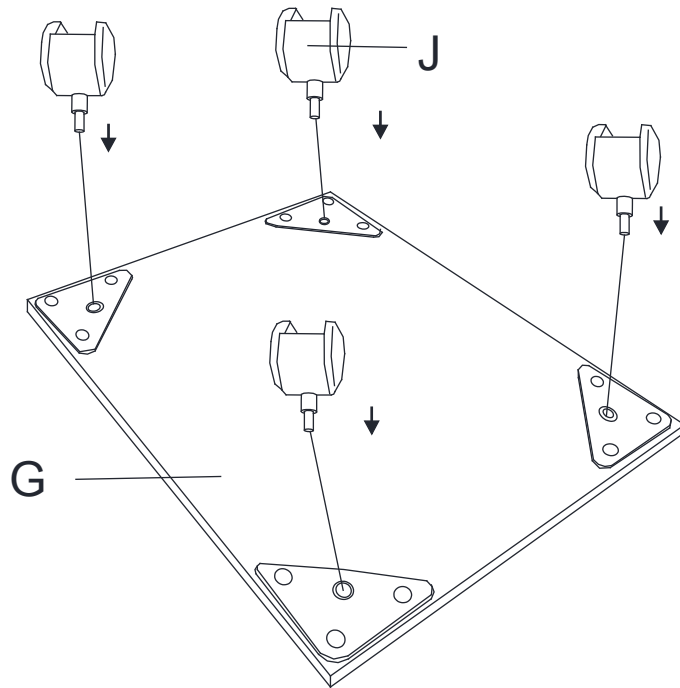

Press the Castor (J) into holes on bottom panel (G)

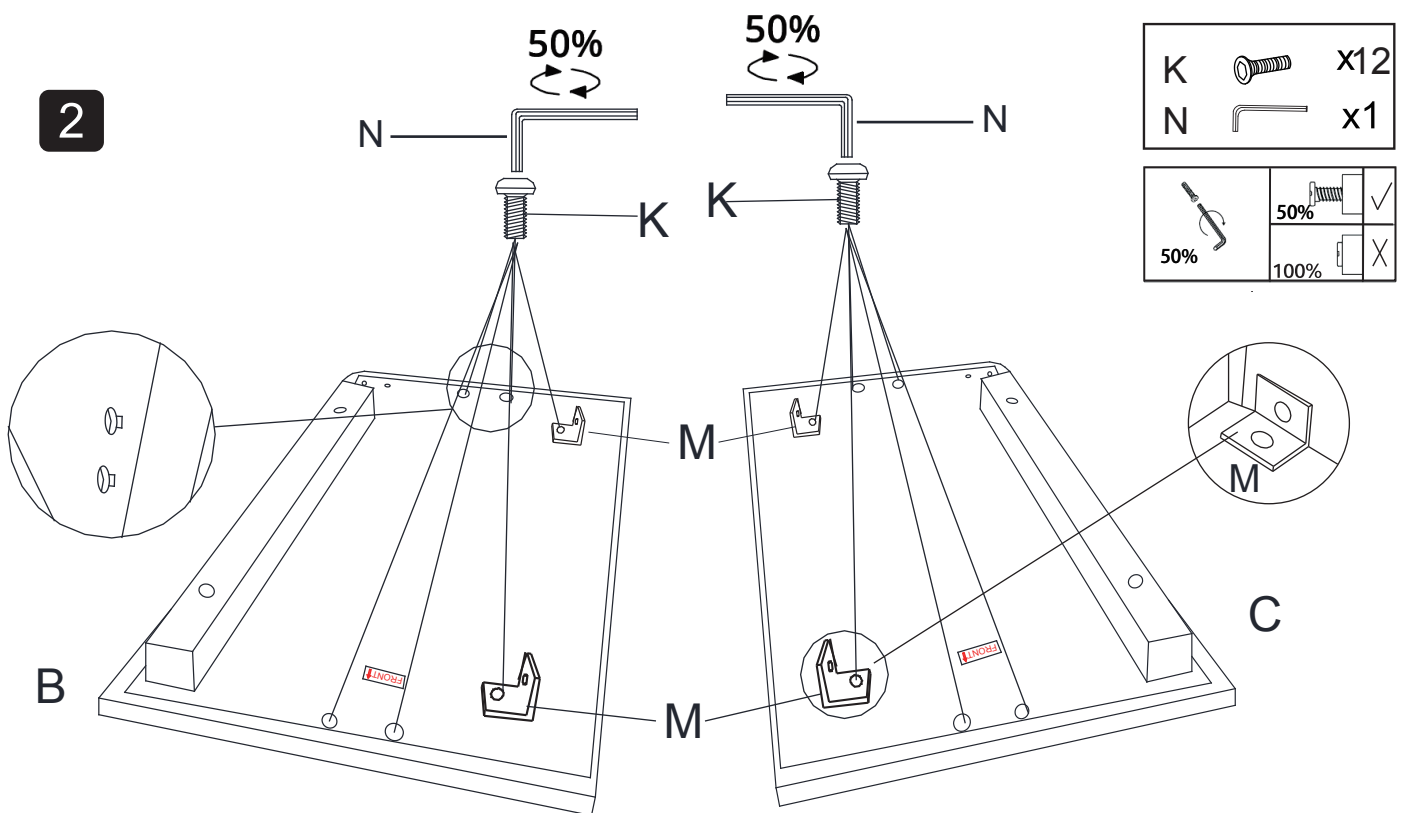

2



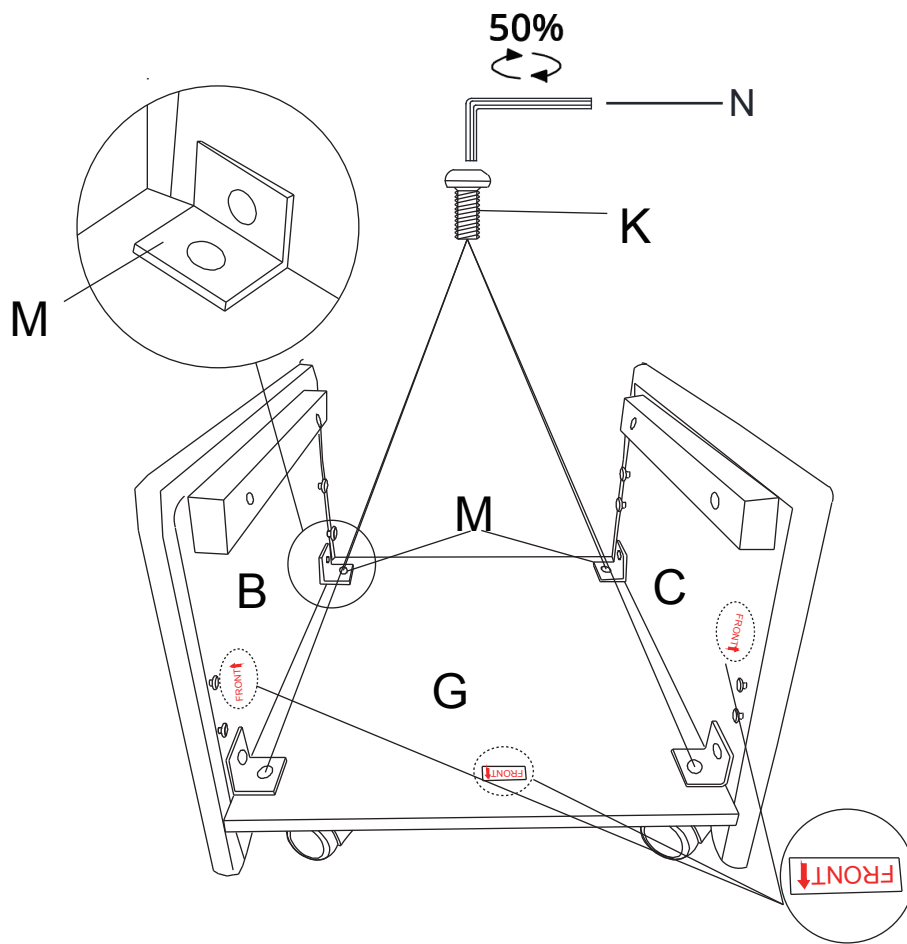

Put Left bottom panel(B) & Right bottom panel(C) on a soft and clean surface, then loosen the eight embedded bolts(K) to 50% by Wrench N. And then attached the Joint bar (M) with screws (K) ,tighten 50%.

3



K		x4
N		x1

	50%		✓
	100%		✗

Connect Left bottom panel(B) & Right bottom panel(C) with the bottom panel(G) by using the 4 pieces of joint bar (M) and bolts (K),tighten 50% at this stage.

4

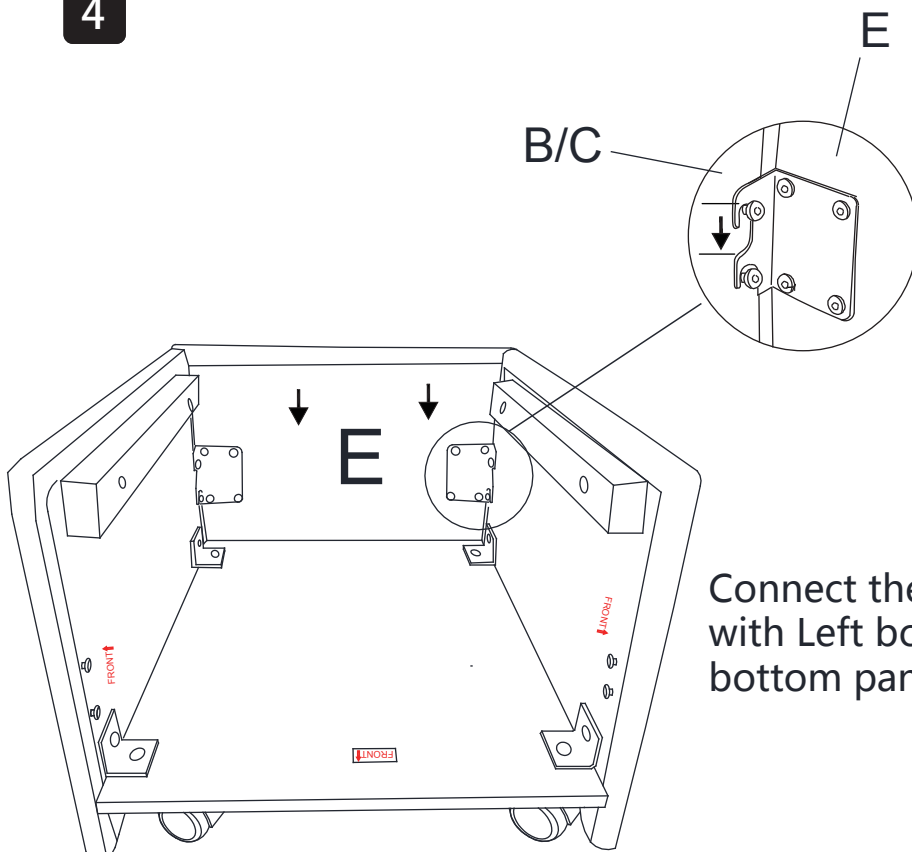

Connect the back bottom panel (E) with Left bottom panel(B) & Right bottom panel(C).

6

5

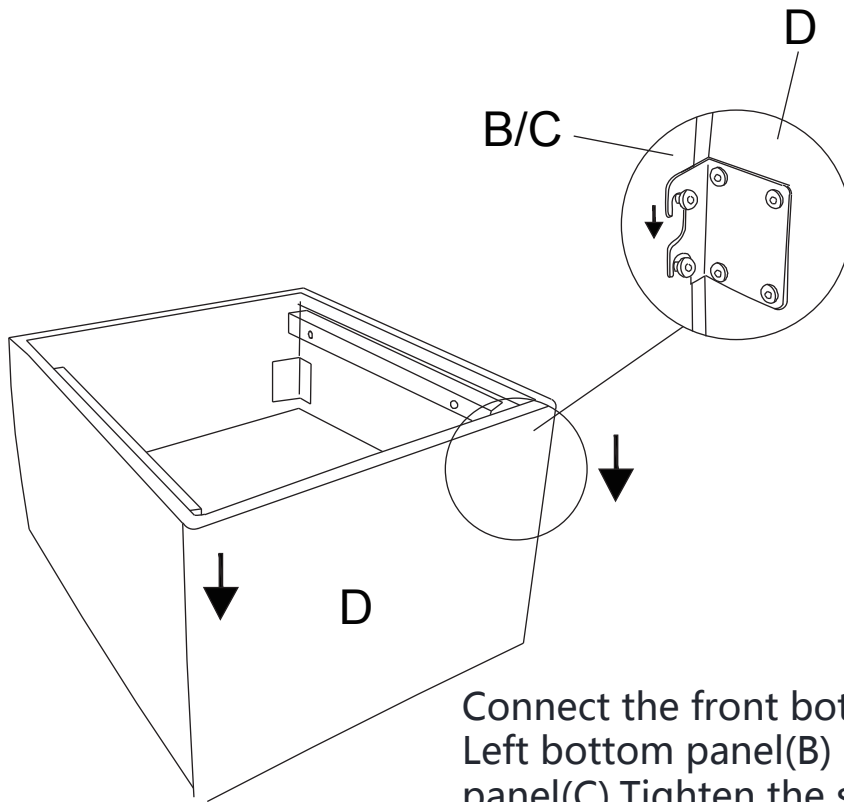

100%			X
			✓

Connect the front bottom panel (D) with Left bottom panel(B) & Right bottom panel(C). Tighten the screws of joint bar & slots inside the bottom frame to 100%.

6

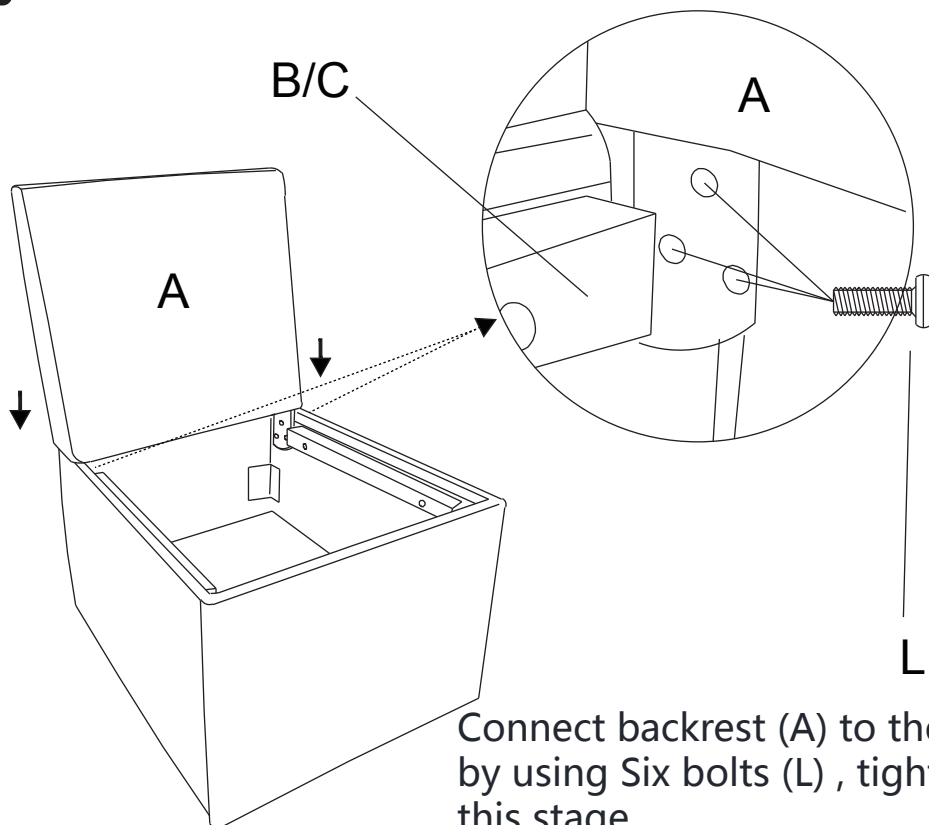

50%			✓
			X

Connect backrest (A) to the bottom panel B/C by using Six bolts (L) , tighten all screws 50% at this stage.

7

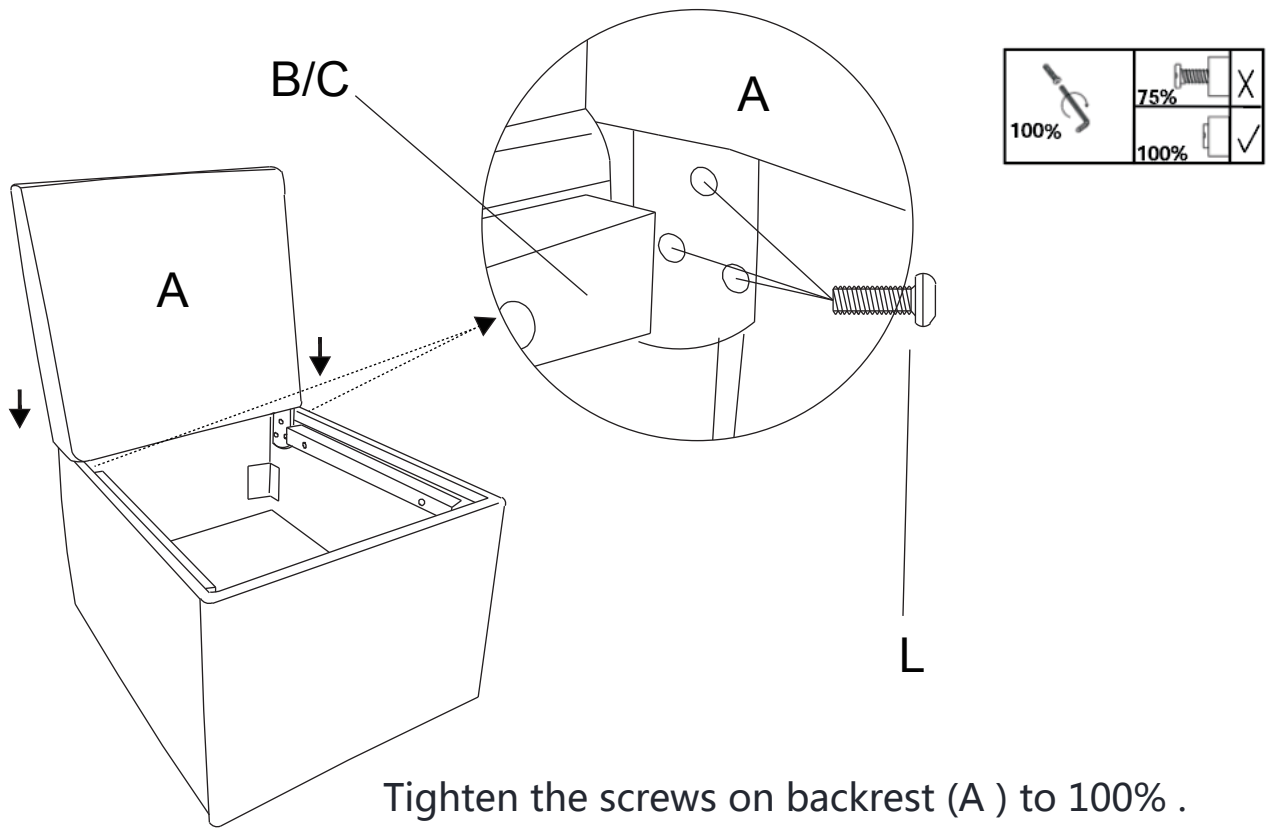

8

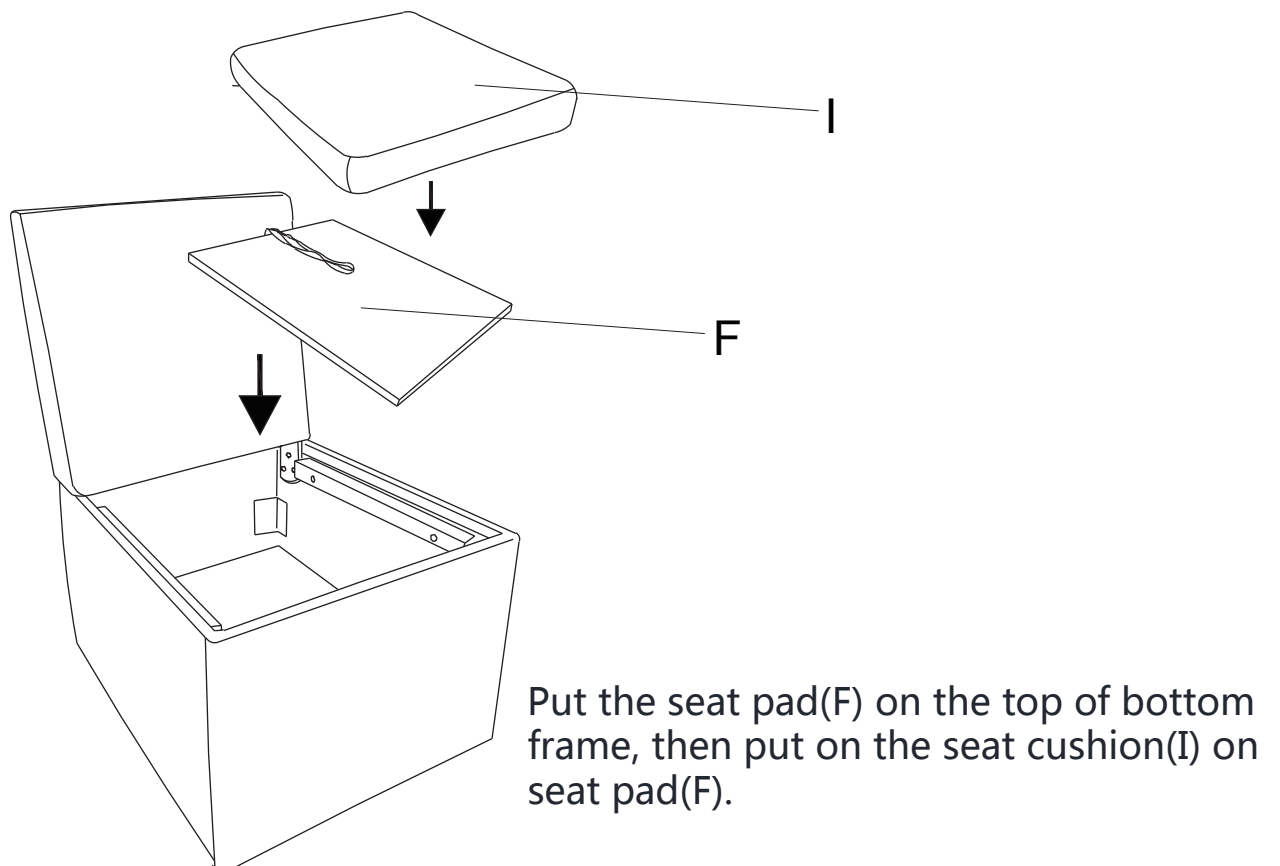

9

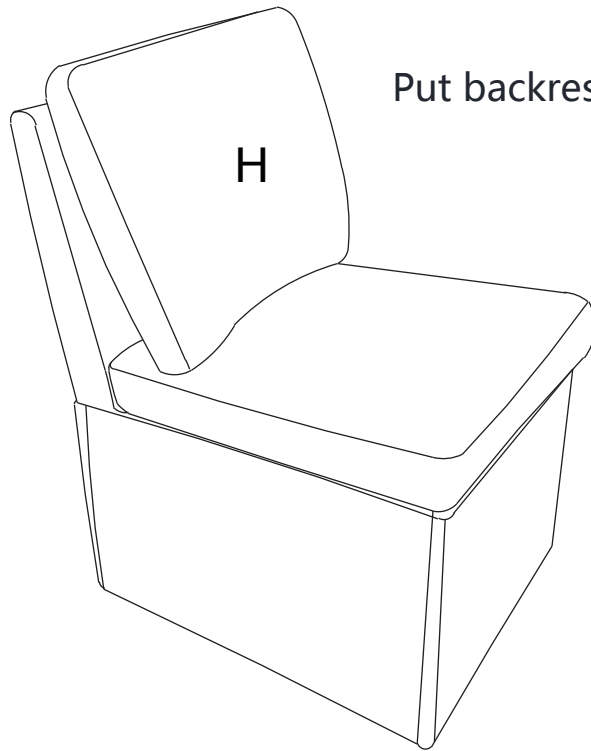

Put backrest(H) on the chair

FINISHED

