



---



# **Instruction Manual**

---

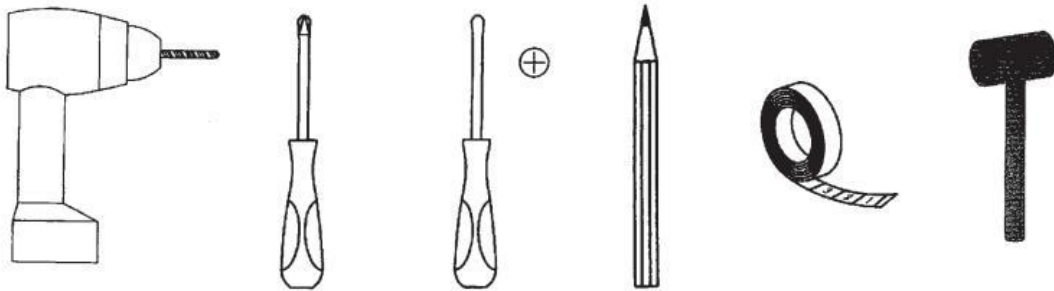

## Tools Required:



	Bolt	Bolzen
	Boulon	Bullone
Perno		
		
Connecting piece Verbindungsbeschlag Pièce de raccord Pezzo di bloccaggio Pieza de sujeción		

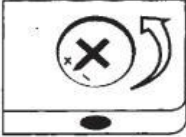

**X**

Adjust connecting piece direction until it is properly lined up with the hole.

Stellen Sie den Verbindungsbeschlag so ein, dass er wie im Bild gezeigt ausgerichtet ist

Ajustez l'écrou selon le schéma

Regolare la direzione di pezzo di collegamento come la condizione illustrata

Ajustar la pieza de sujeción según la dirección ilustrada

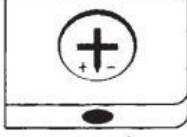

**✓**

Insert bolt when connecting piece direction is properly lined up.

Setzen Sie erst dann den Bolzen ein

Insérez le boulon quand la pièce de raccord est dans telle condition

Inserire il bullone quando il pezzo di collegamento è in tale condizione

Insertar el perno cuando se encuentre así la pieza de sujeción

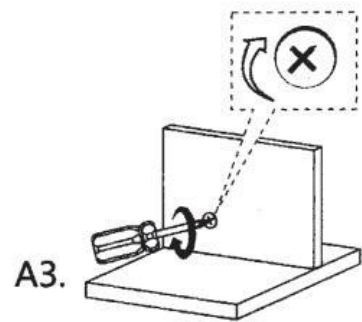
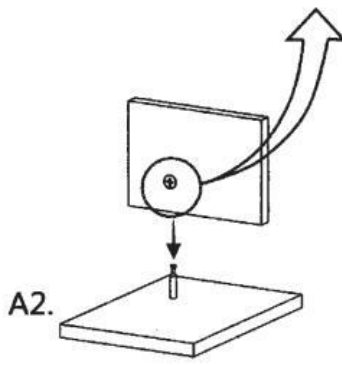
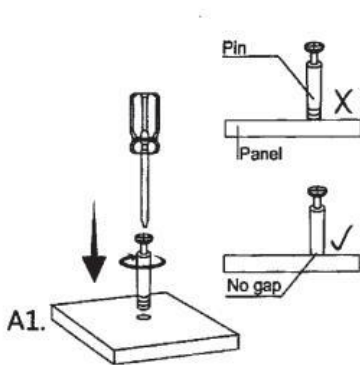

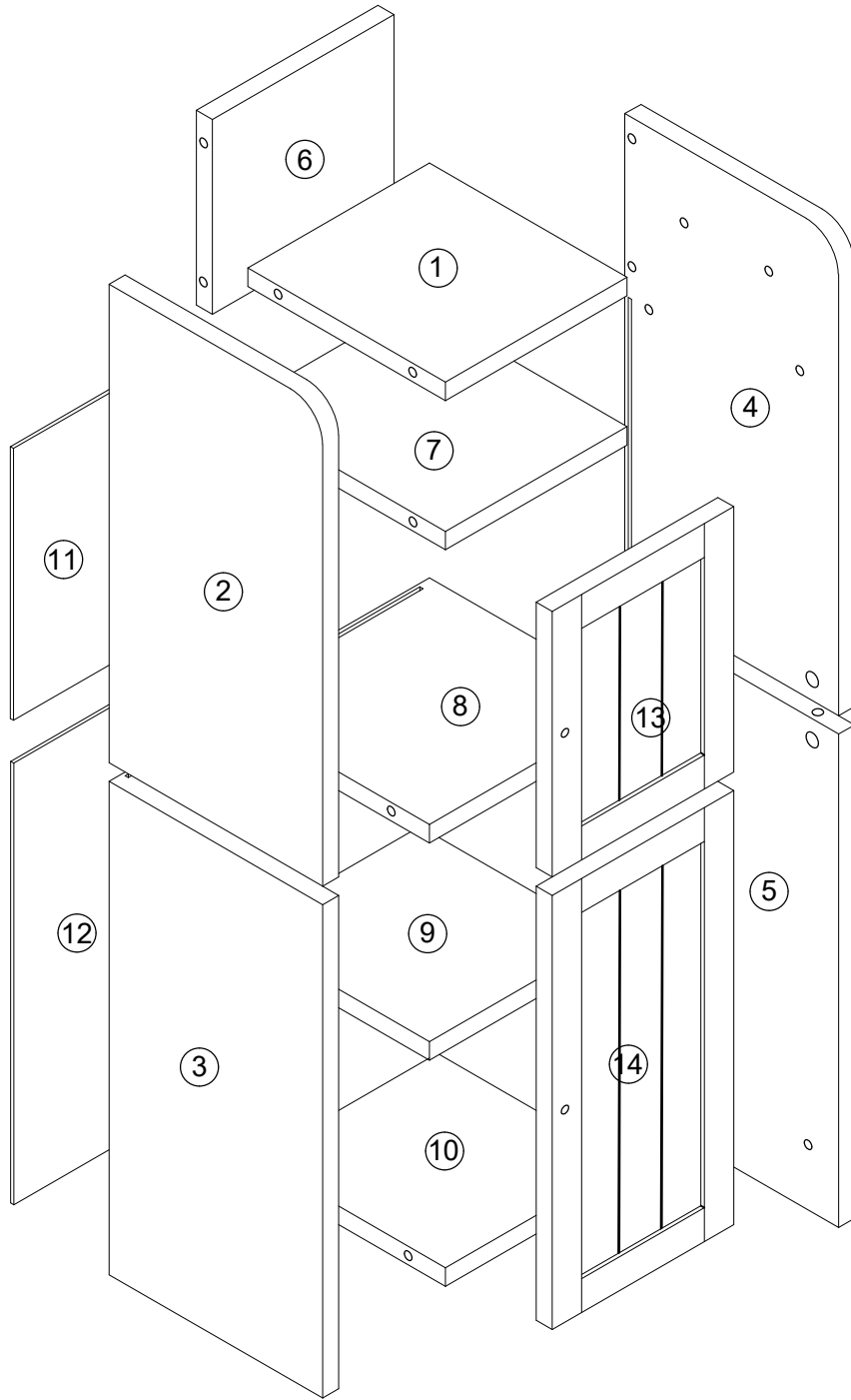

## HARDWARE LIST

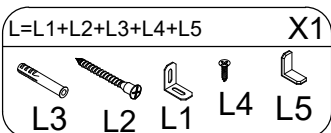
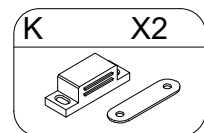
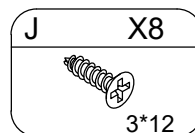
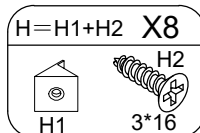
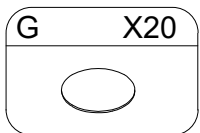
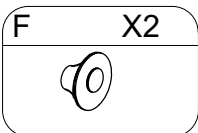
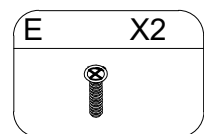
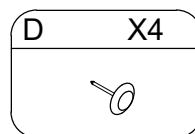
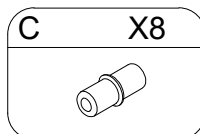
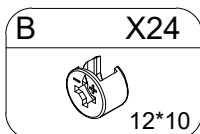
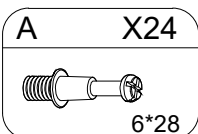

1

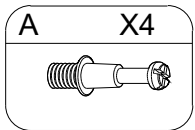
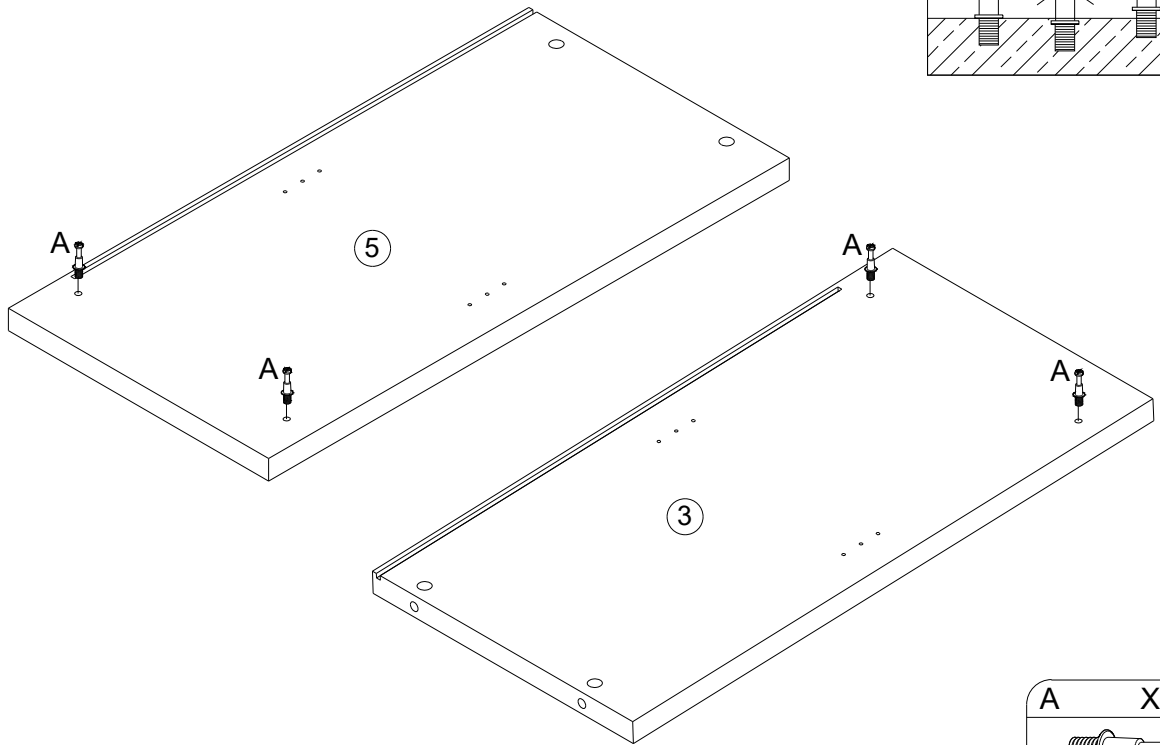

2

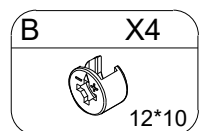
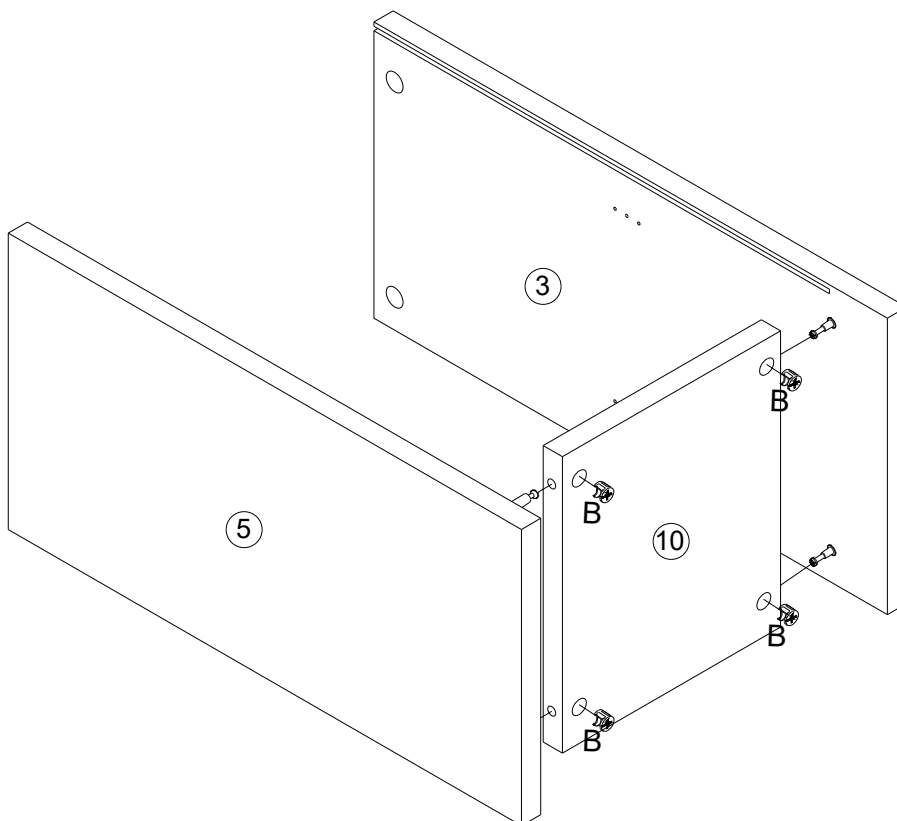

3

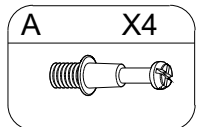
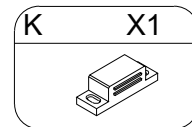
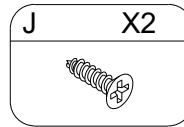
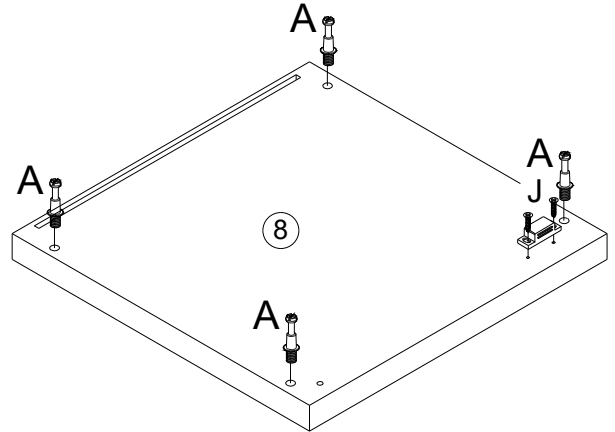
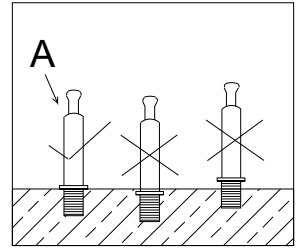
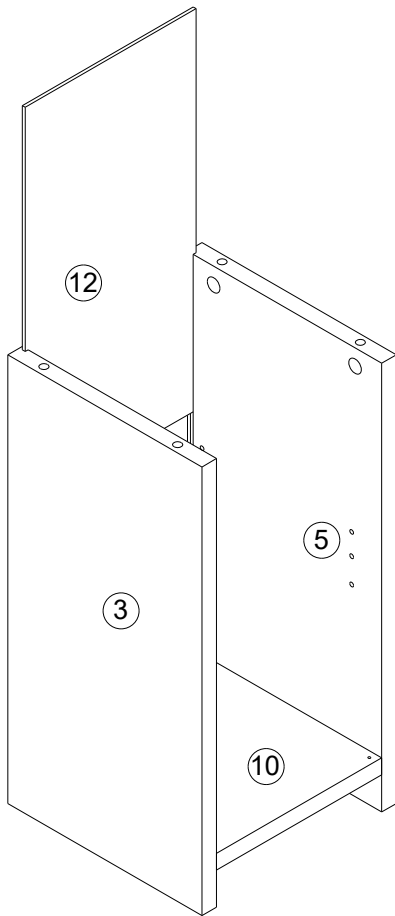

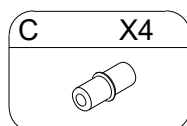
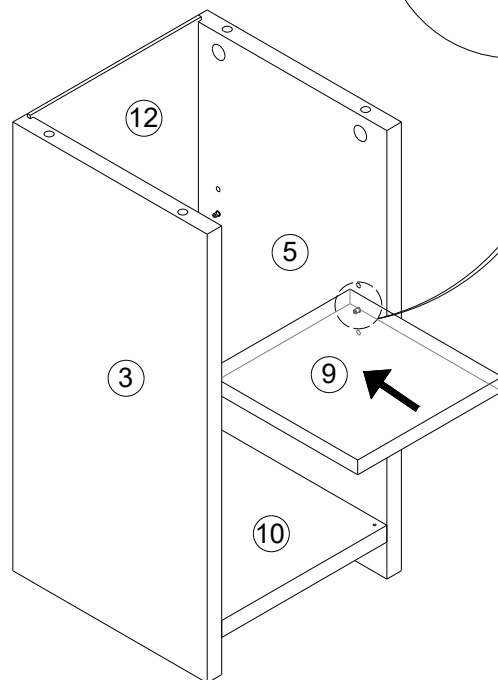
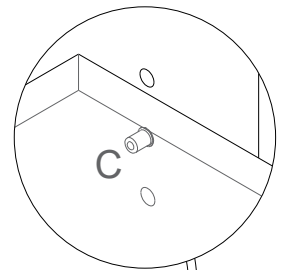
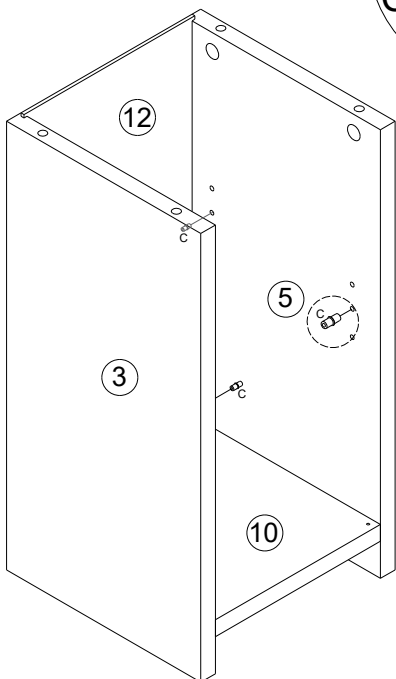
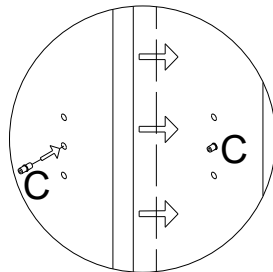

4



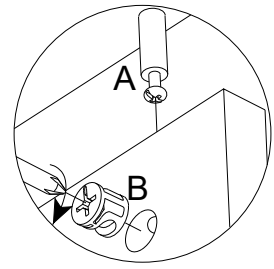
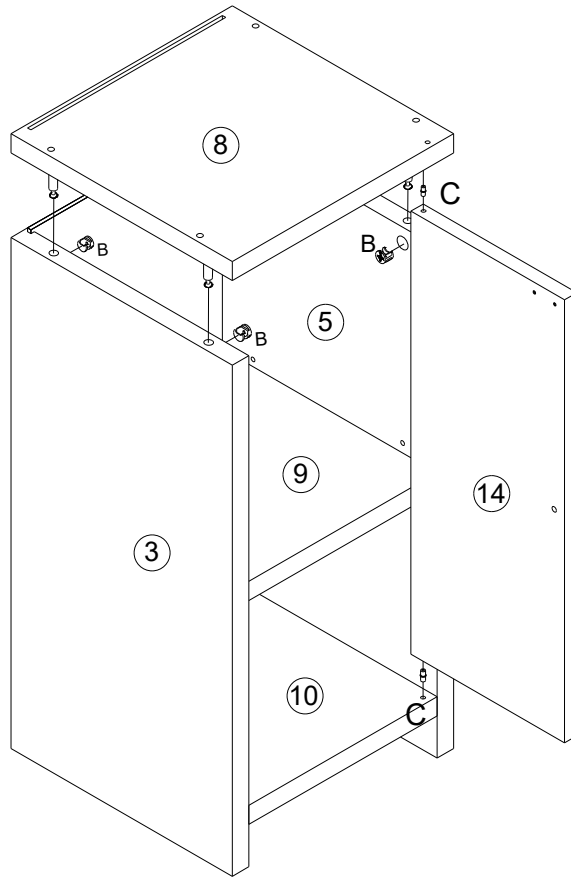

5

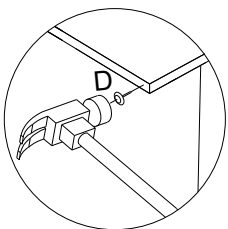
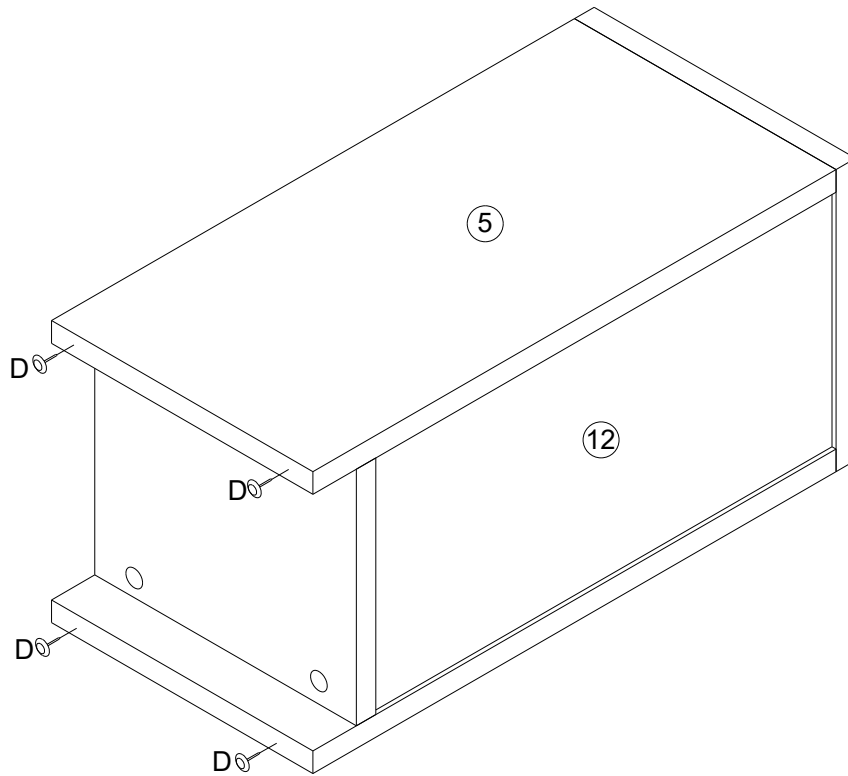

C	X2
	
B	X4
	
12*10	

6



D	X4
	

7

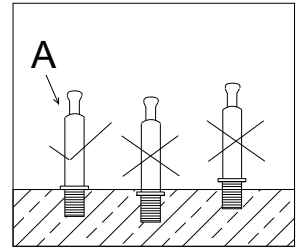
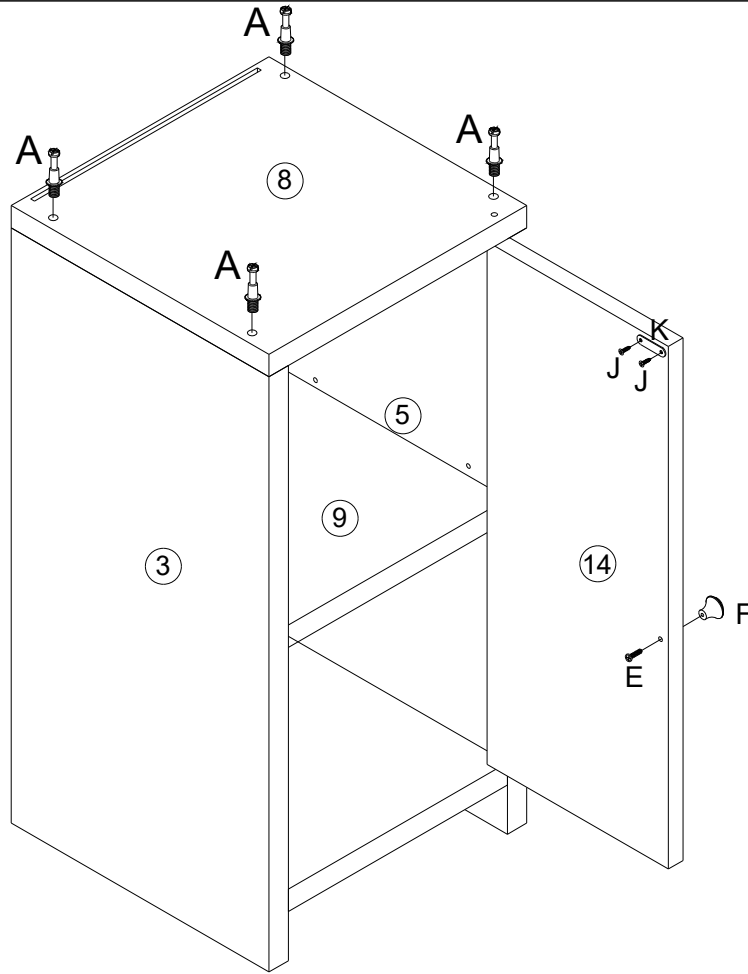

- K X1
- J X2
- A X4
- F X1
- E X1

8

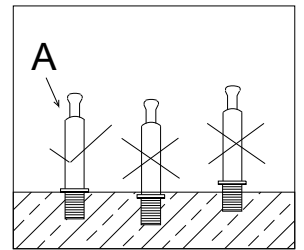
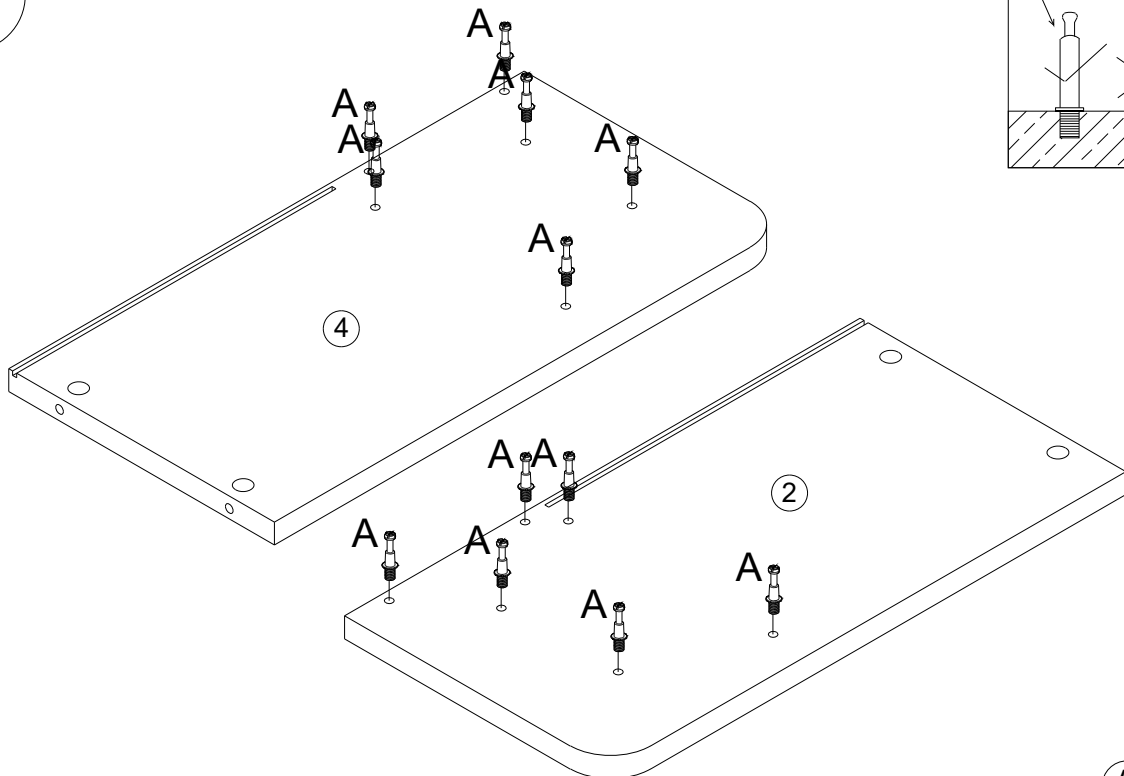

- A X12

9

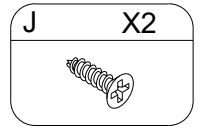
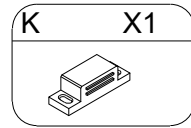
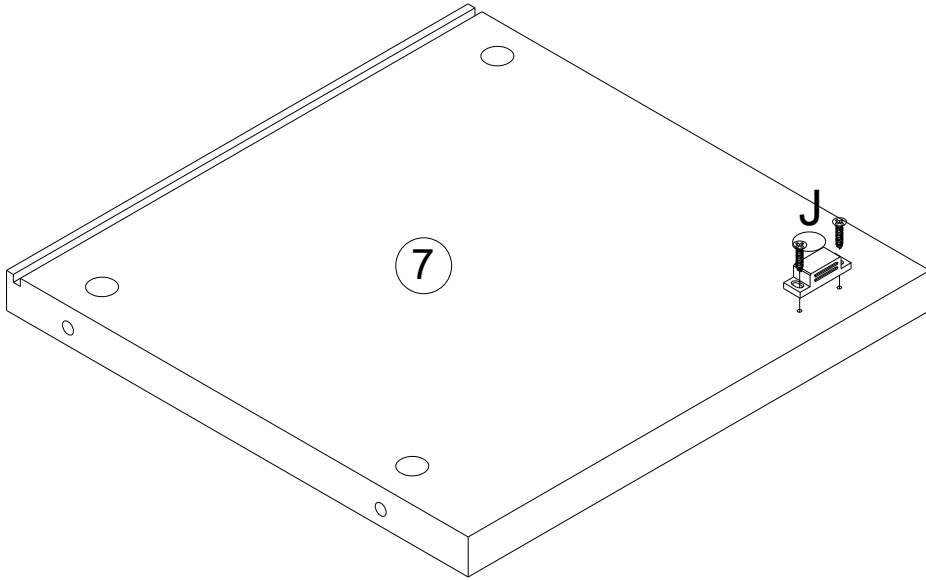

10

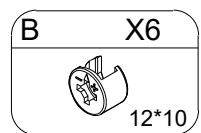
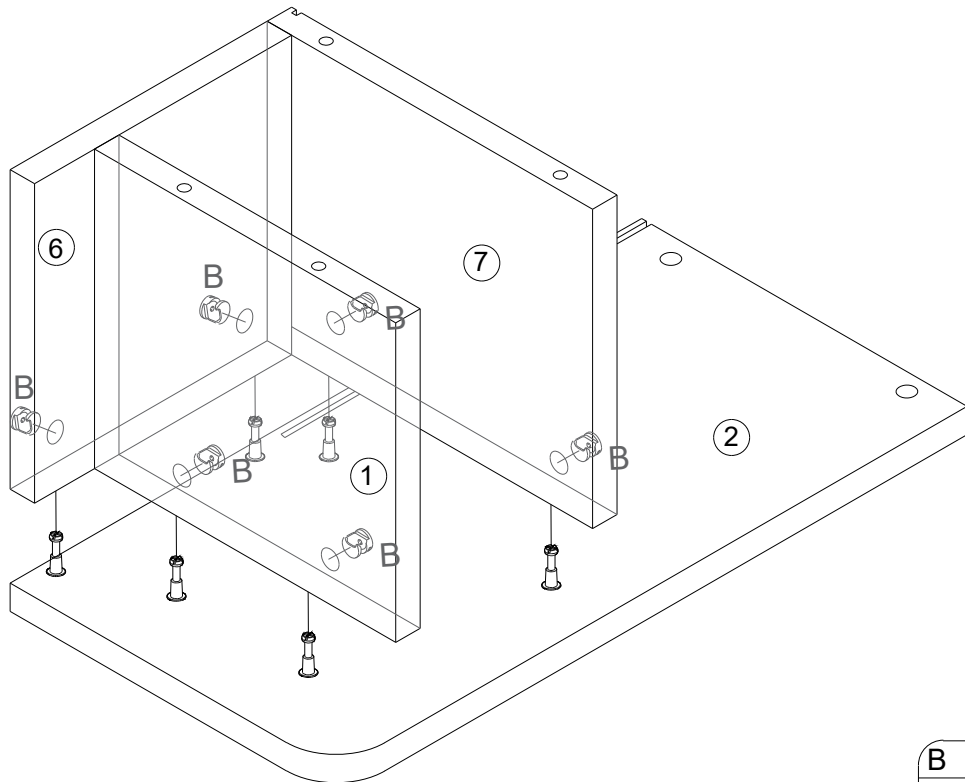



11

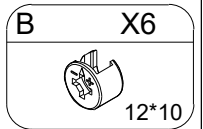
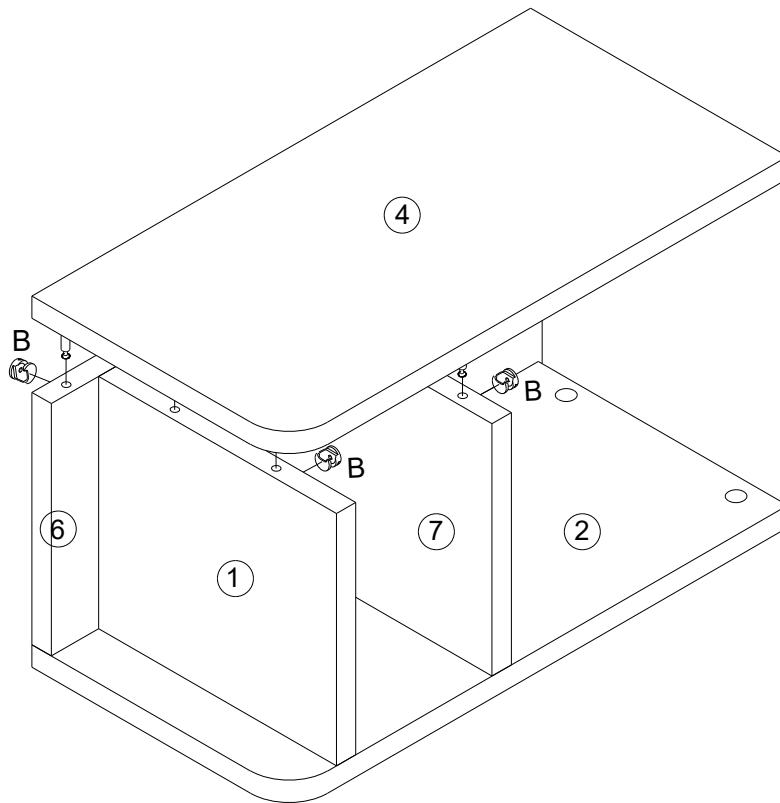

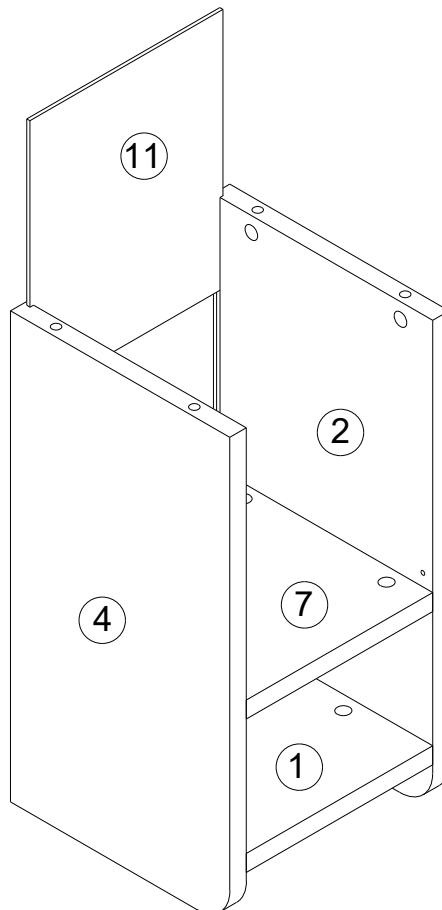

12



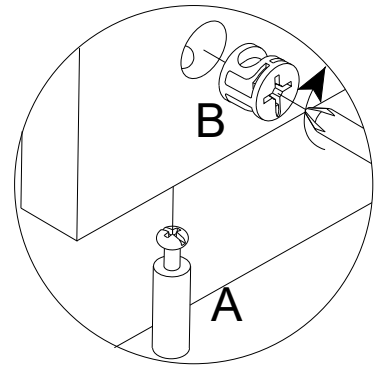
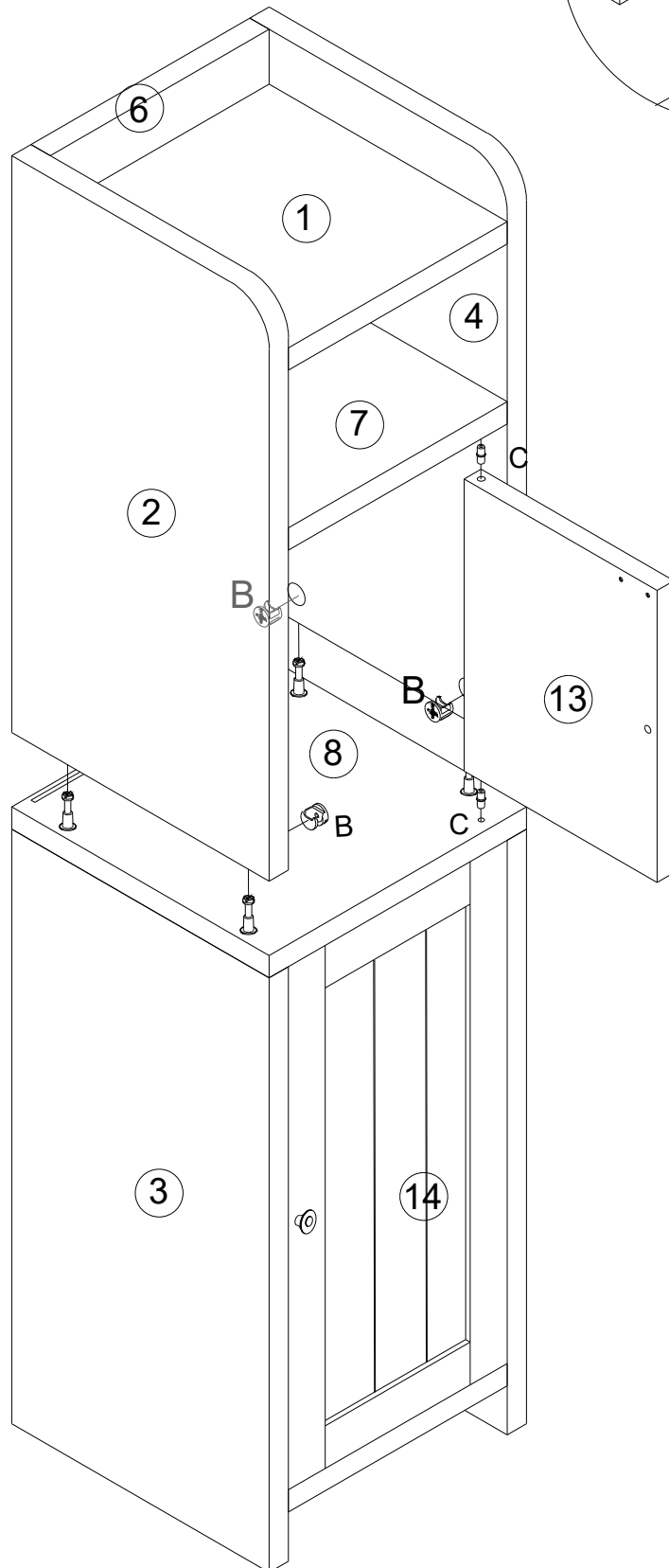



13

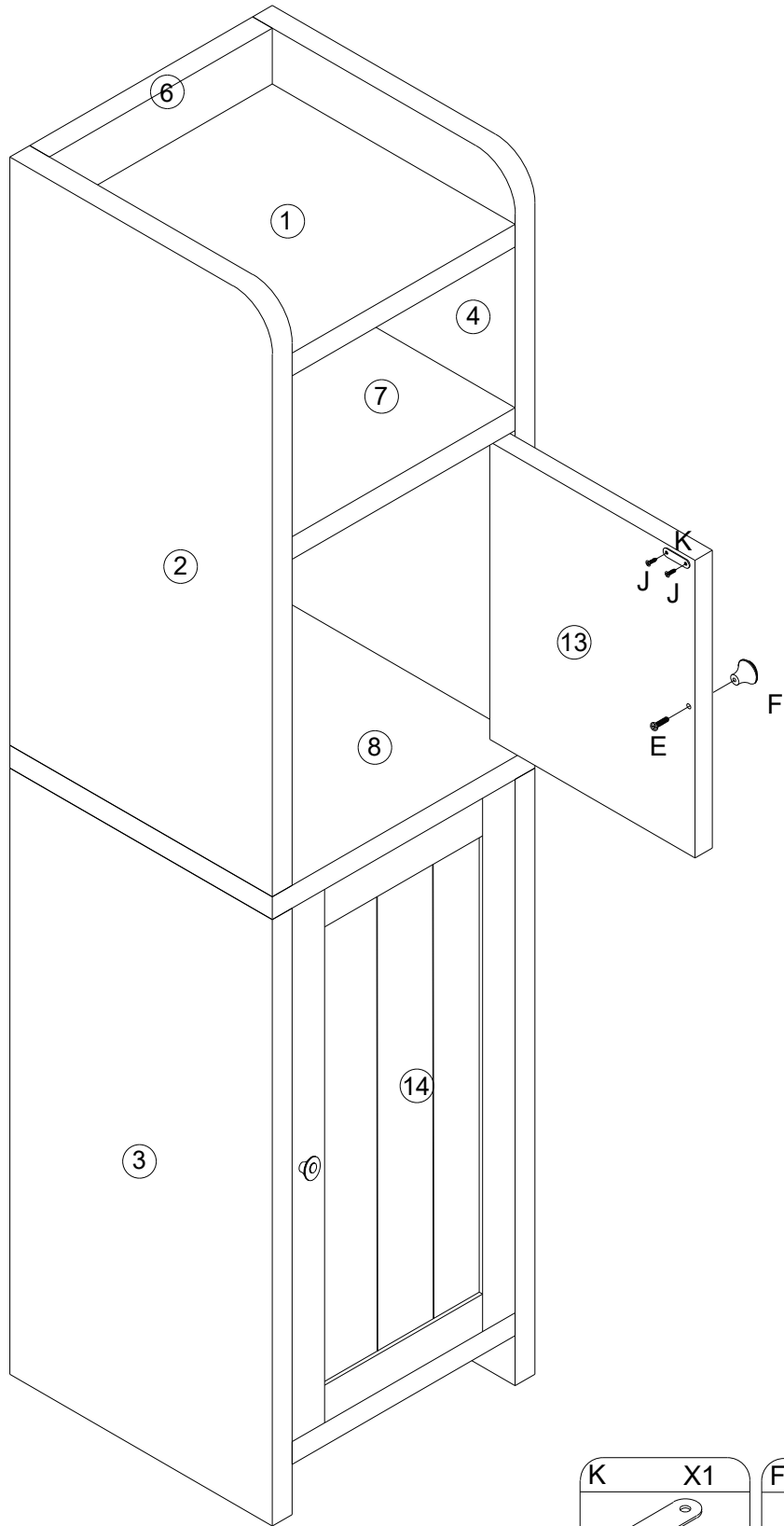

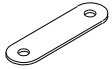
C	X2
	
B	X4
	12*10



K	X1	F	X1
			
J	X2	E	X1
			

15

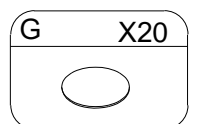
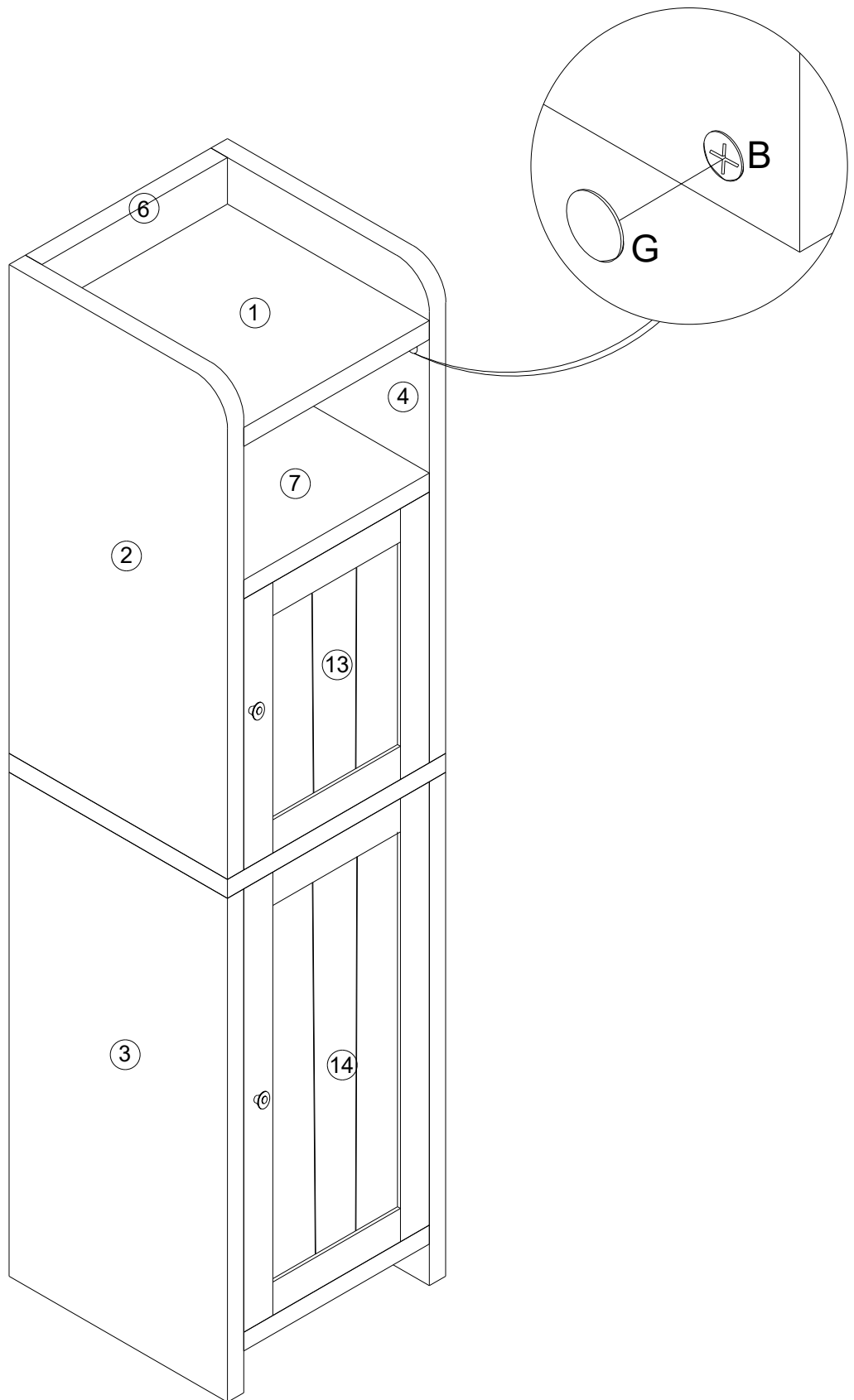

16

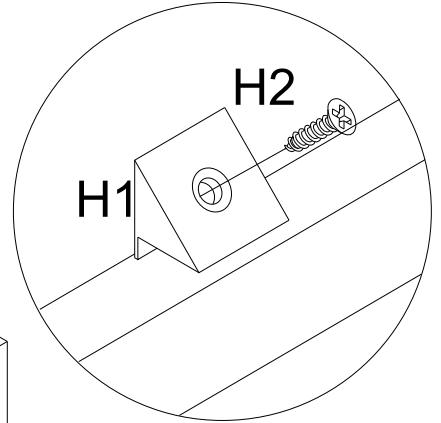
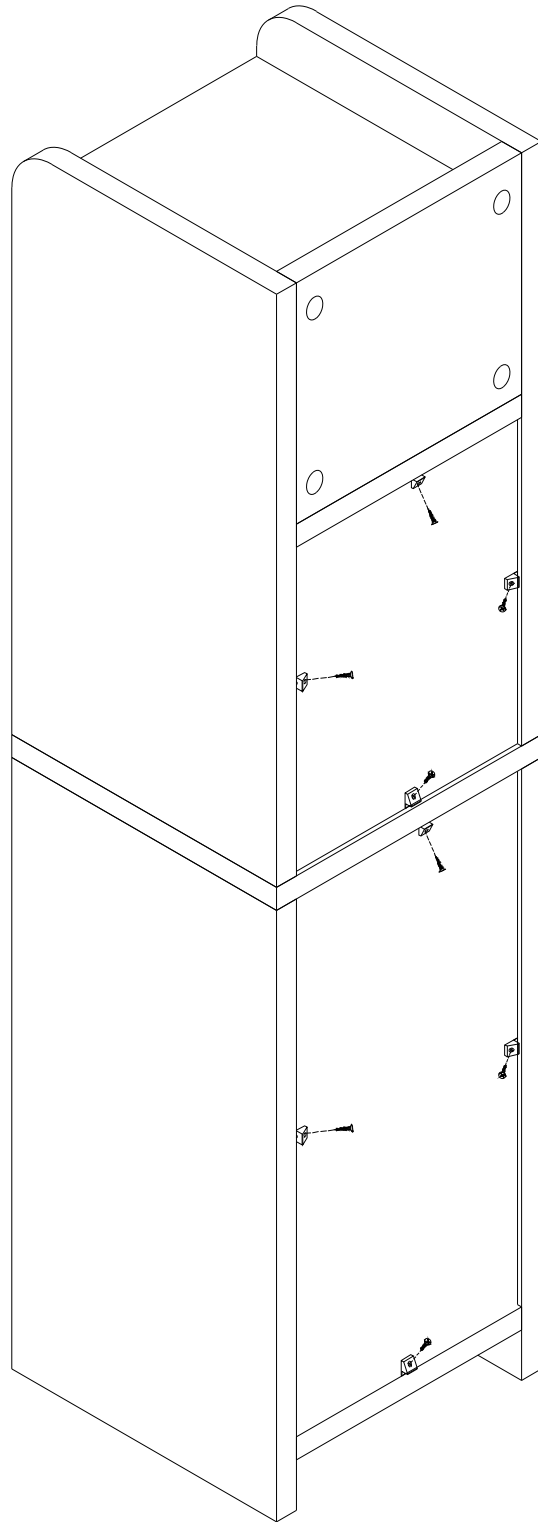

$H = H1 + H2$  X8



H1



H2

3\*16

17

*Note: If you find the magnet's attraction too strong, you can try adjusting either side of the magnet forward or backward to modify its suction strength.*

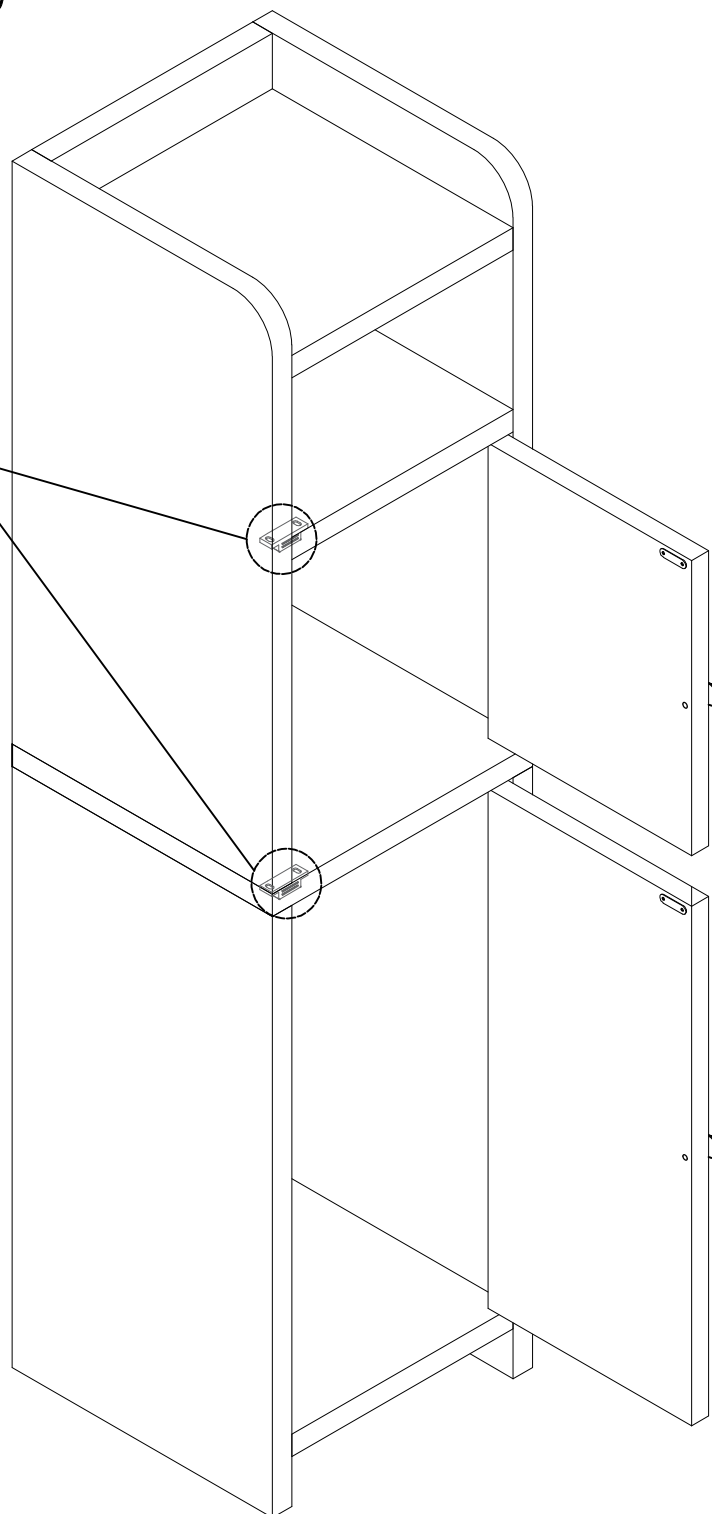
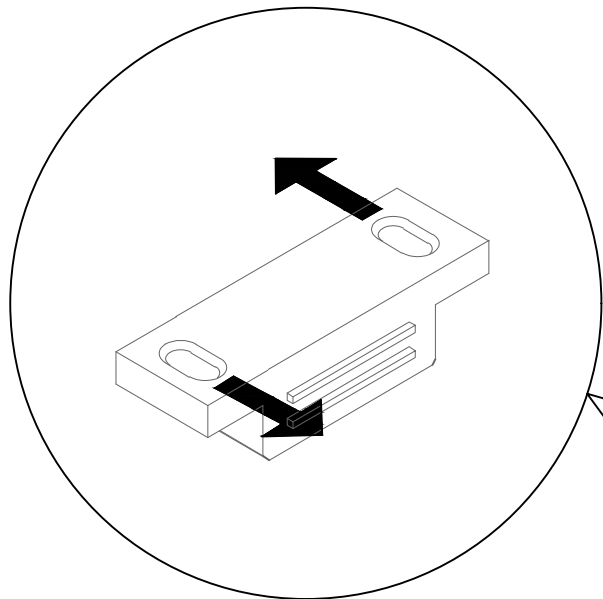

18

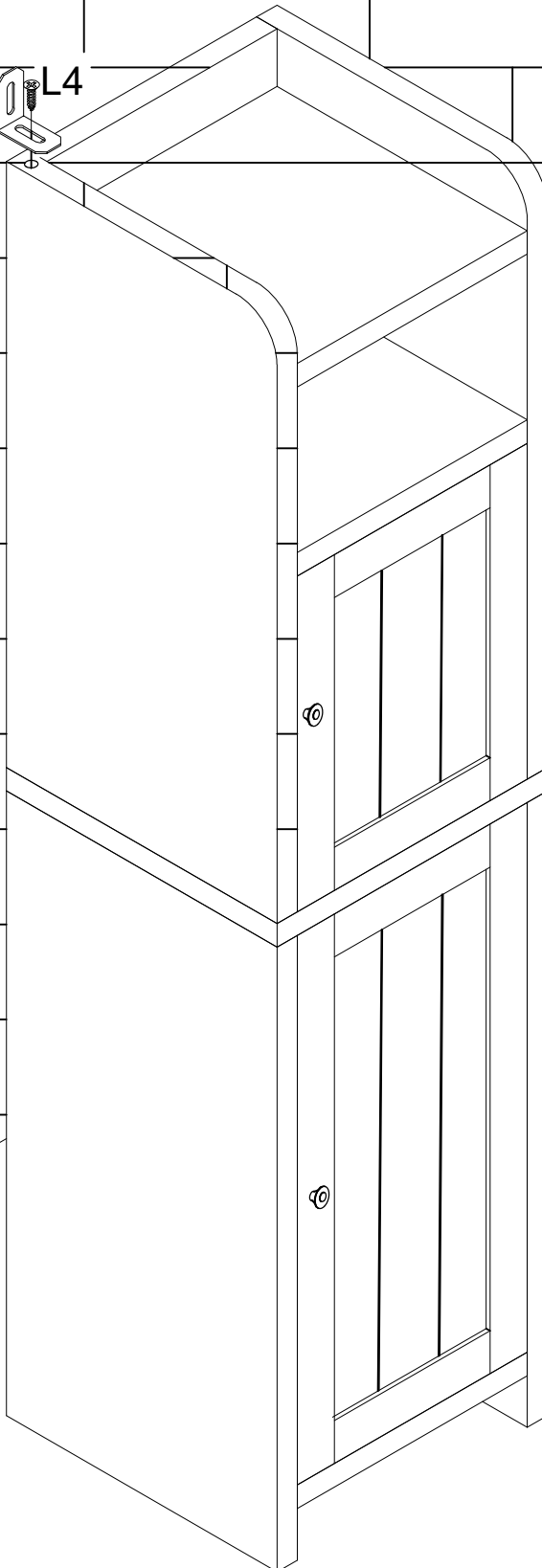
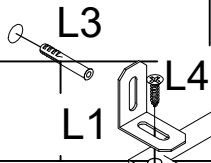

$L=L1+L3+L4$  XL

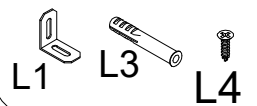

19

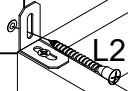
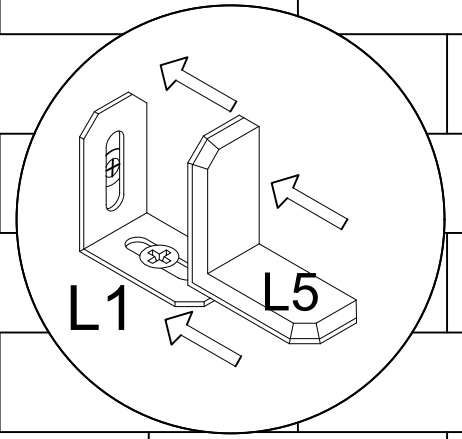

$L=L2+L5$  X1

L2 L5



