

# Assembly Instructions

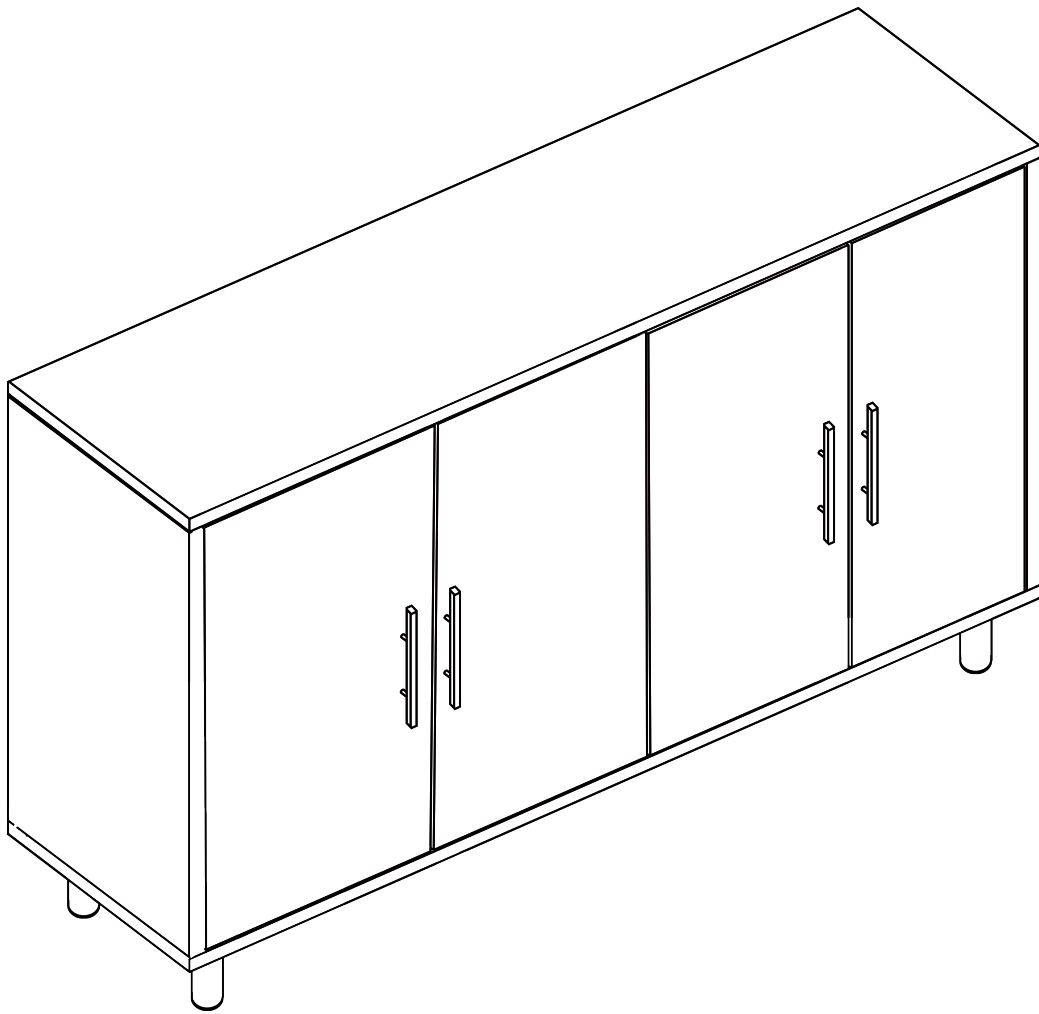

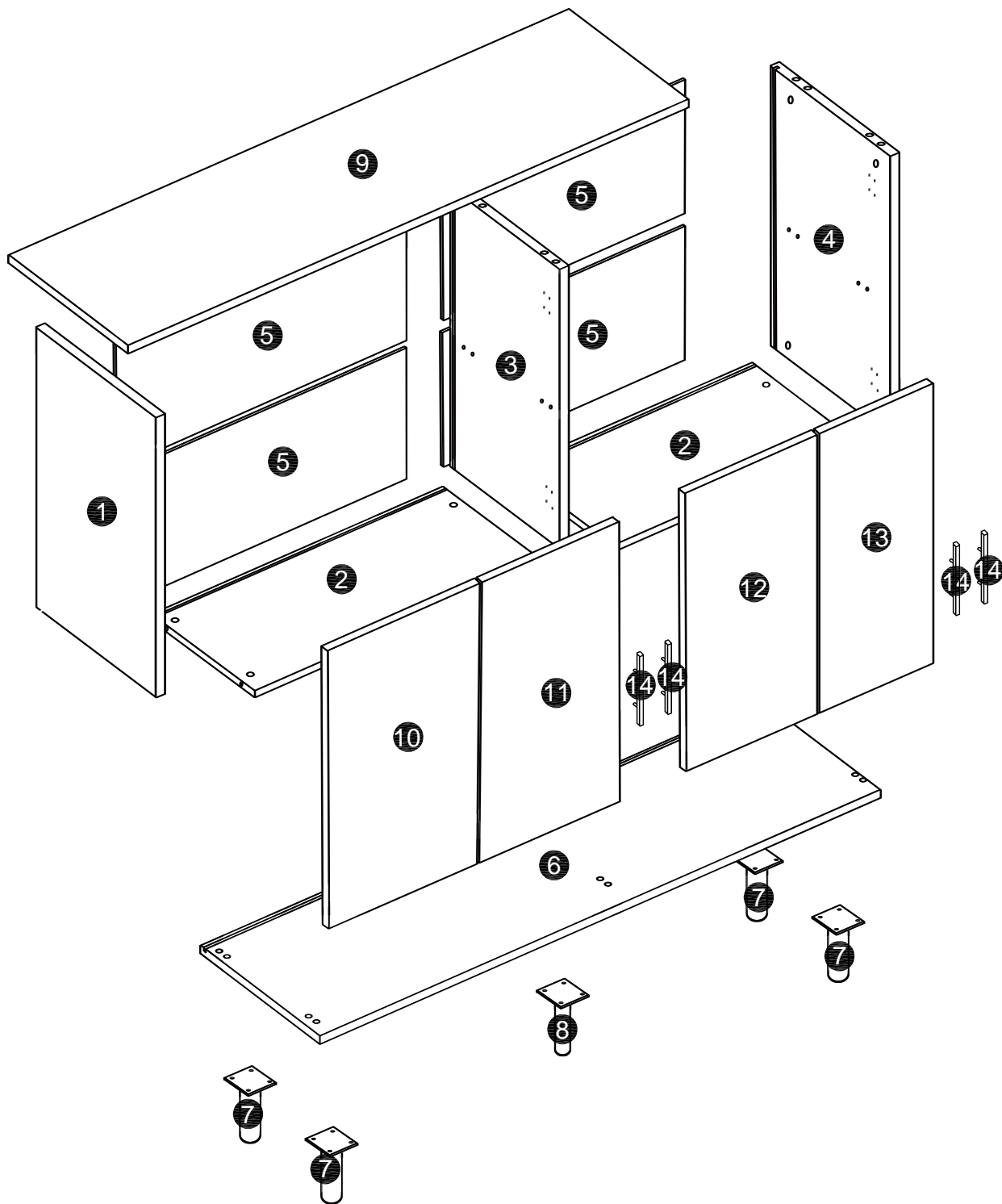





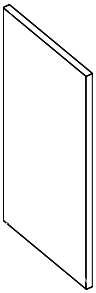
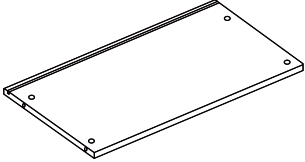
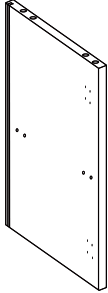
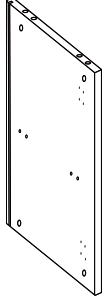
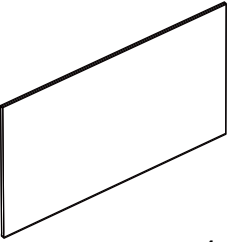
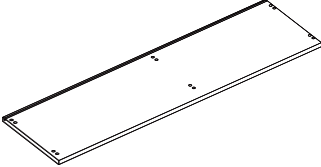
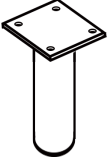
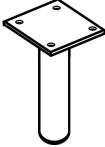
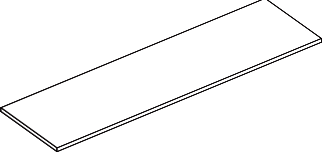
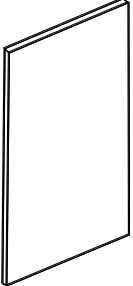
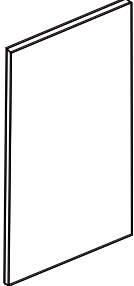
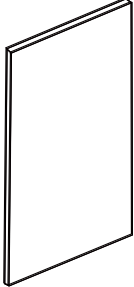
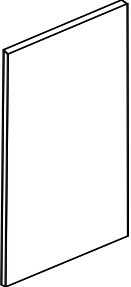

**⚠ Caution**



Make sure all parts are included. Most board parts are labeled or stamped on the raw edge. Contact us for a free replacement if you encounter any damaged or missing parts.

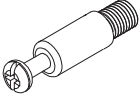
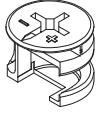
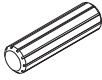
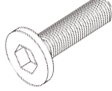

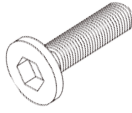

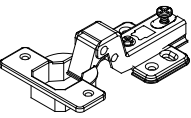
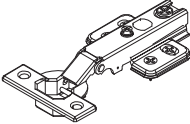
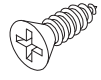
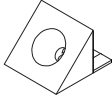

# Parts List

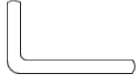
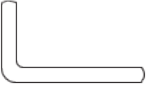
 <p>1</p> <p>1 pc</p>	 <p>2</p> <p>2 pcs</p>	 <p>3</p> <p>1 pc</p>	 <p>4</p> <p>1 pc</p>
 <p>5</p> <p>4 pcs</p>	 <p>6</p> <p>1 pc</p>	 <p>7</p> <p>4 pcs</p>	 <p>8</p> <p>1 pc</p>
 <p>9</p> <p>1 pc</p>	 <p>10</p> <p>1 pc</p>	 <p>11</p> <p>1pc</p>	 <p>12</p> <p>1 pc</p>
 <p>13</p> <p>1 pc</p>	 <p>14</p> <p>4 pcs</p>		

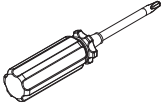
# Hardware List

A	B	C	D	E	F	G
			 Ø 6 x 20mm	 Ø 8 x 16mm	 Ø 8 x 16mm	 Ø 4 x 12mm
20 pcs	20 pcs	20 pcs	8 pcs	28 pcs	20 pcs	16 pcs

H	I	J	K	L	M	N
		 Ø 4 x 14mm		 Ø 4 x 16mm		
4 pcs	4 pcs	48 pcs	16 pcs	16 pcs	1 pc	1 pc

O	P	P1	P2	Q	R	
					 Ø 6 x 13mm	
1 pc	4 pcs	4 pcs	4 pcs	2 pcs	8 pcs	

# Installation of Cams and Pins

Read each step carefully before starting. Each step of instruction should be performed in the correct order. If these steps are not followed in sequence, assembly difficulties may occur.

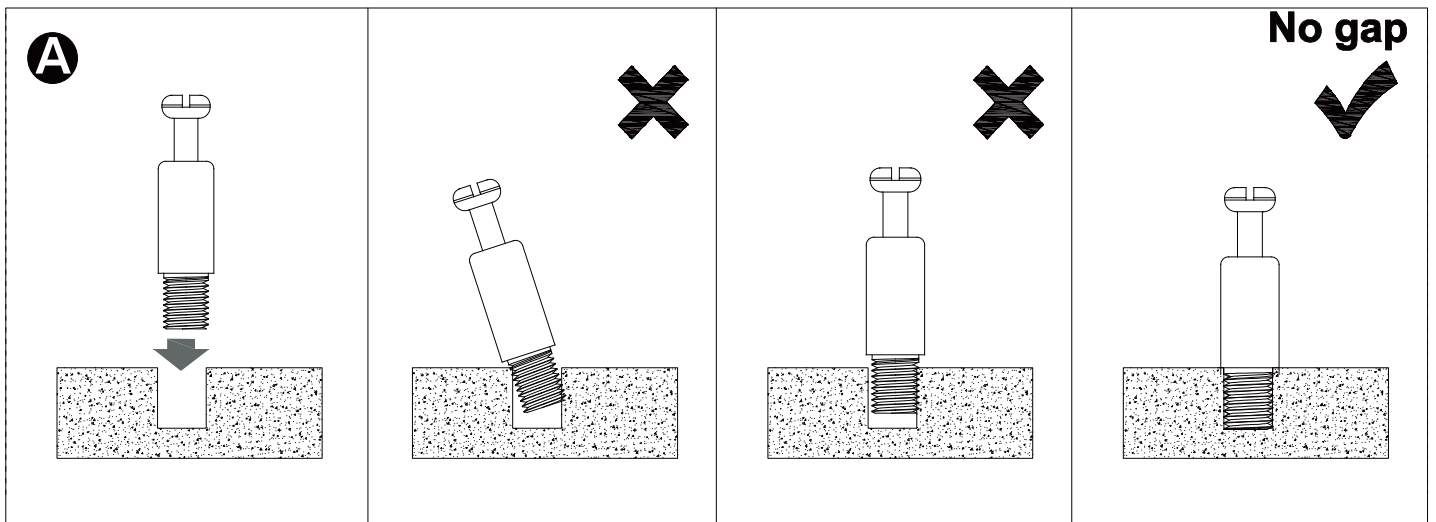
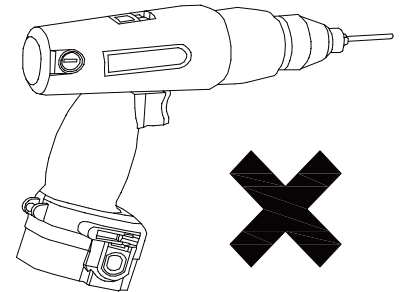

Screw the pin into the hole. Set the cams correctly by aligning the head of the cams with the lock pins. Lock the cam by turning the cam head with a screwdriver until it is tightened. Please do not use an electric screwdriver to assemble the unit.

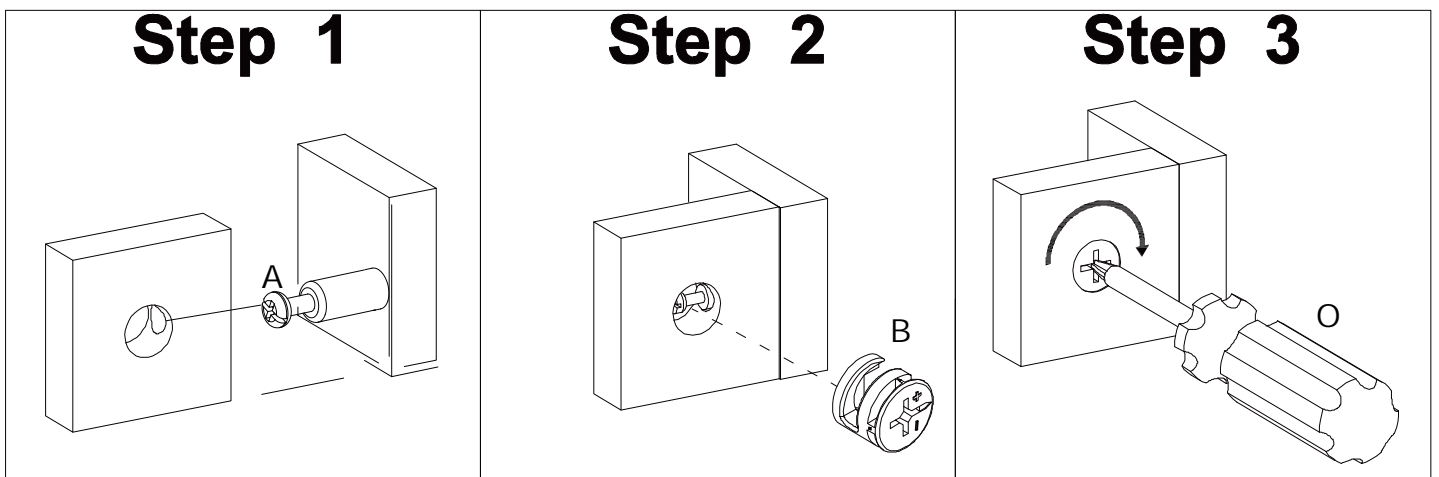

1

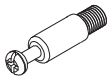
A

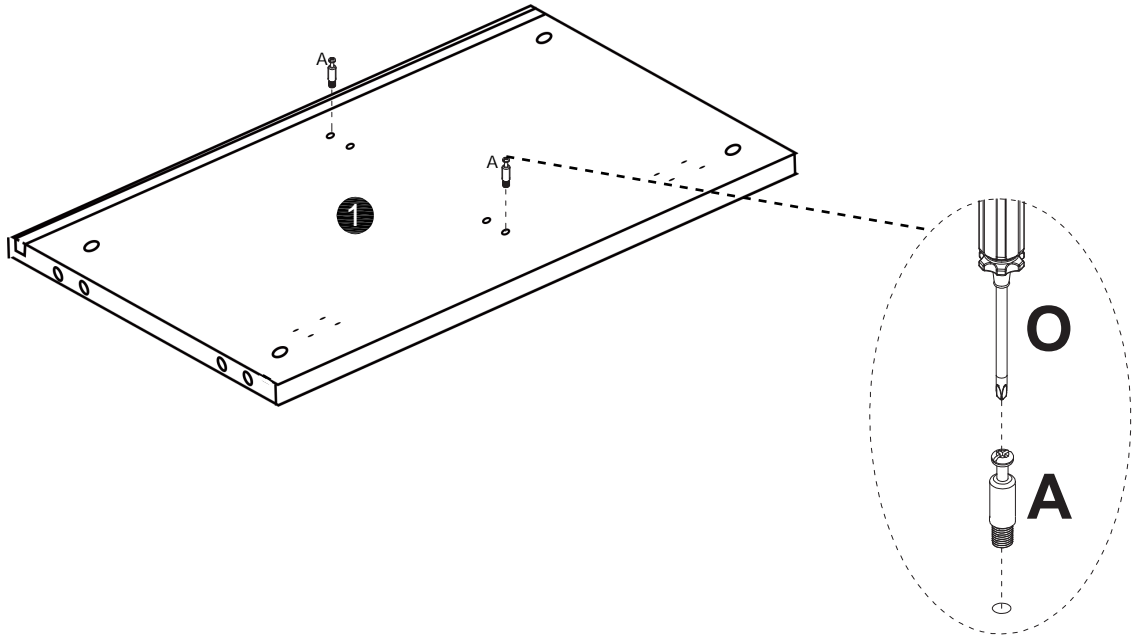
2 pcs

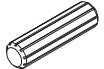

2

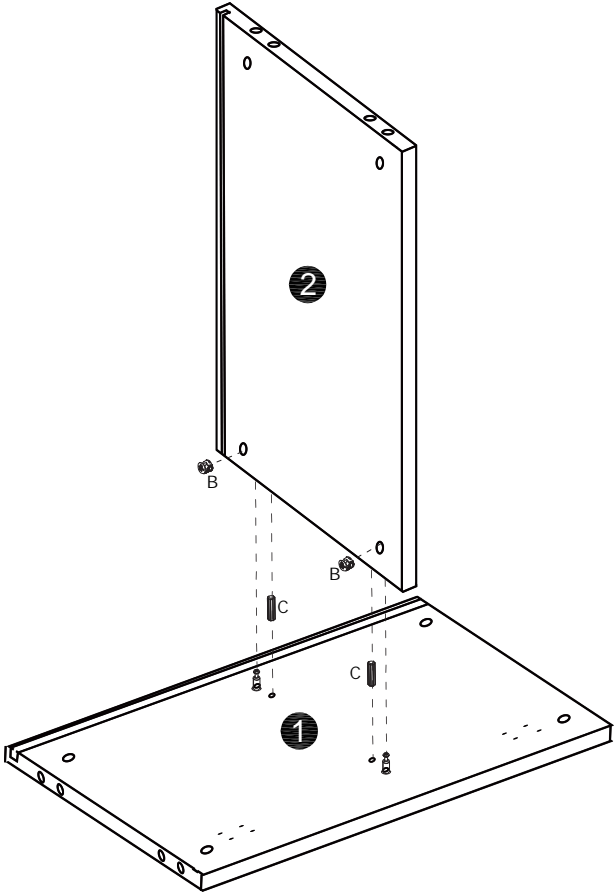
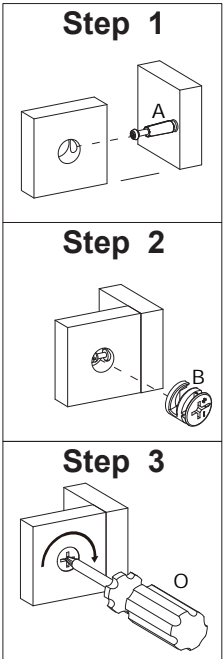
B	C
	
2 pcs	2 pcs



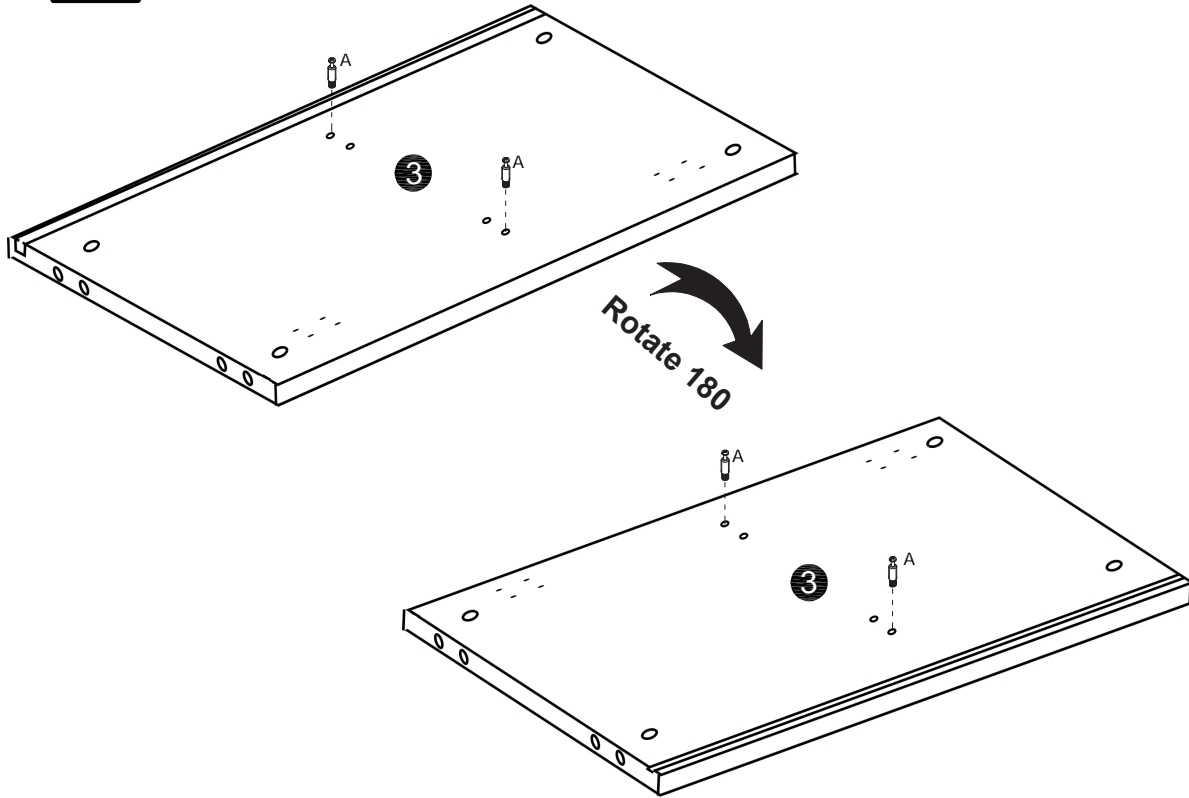

**3**

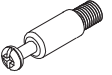

<b>A</b>

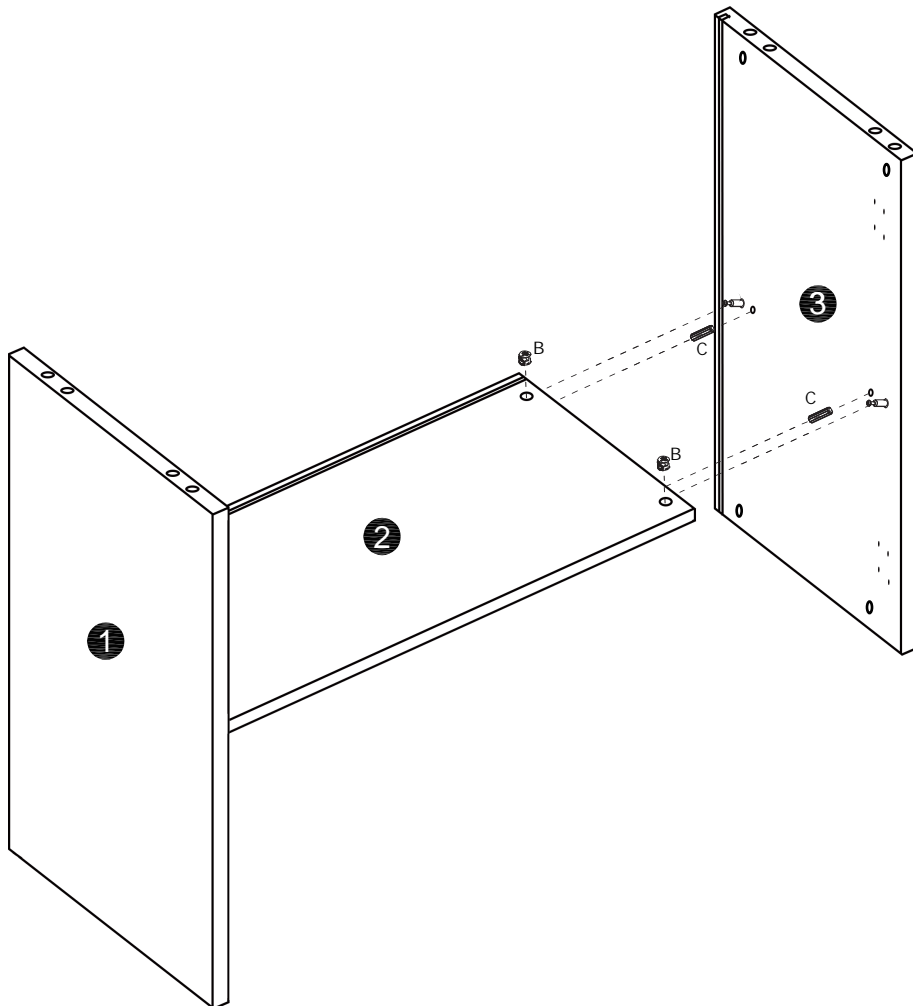
4 pcs

**4**

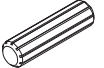

<b>B</b>	<b>C</b>
	
2 pcs	2 pcs

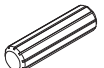
5

B	C
	
2 pcs	2 pcs

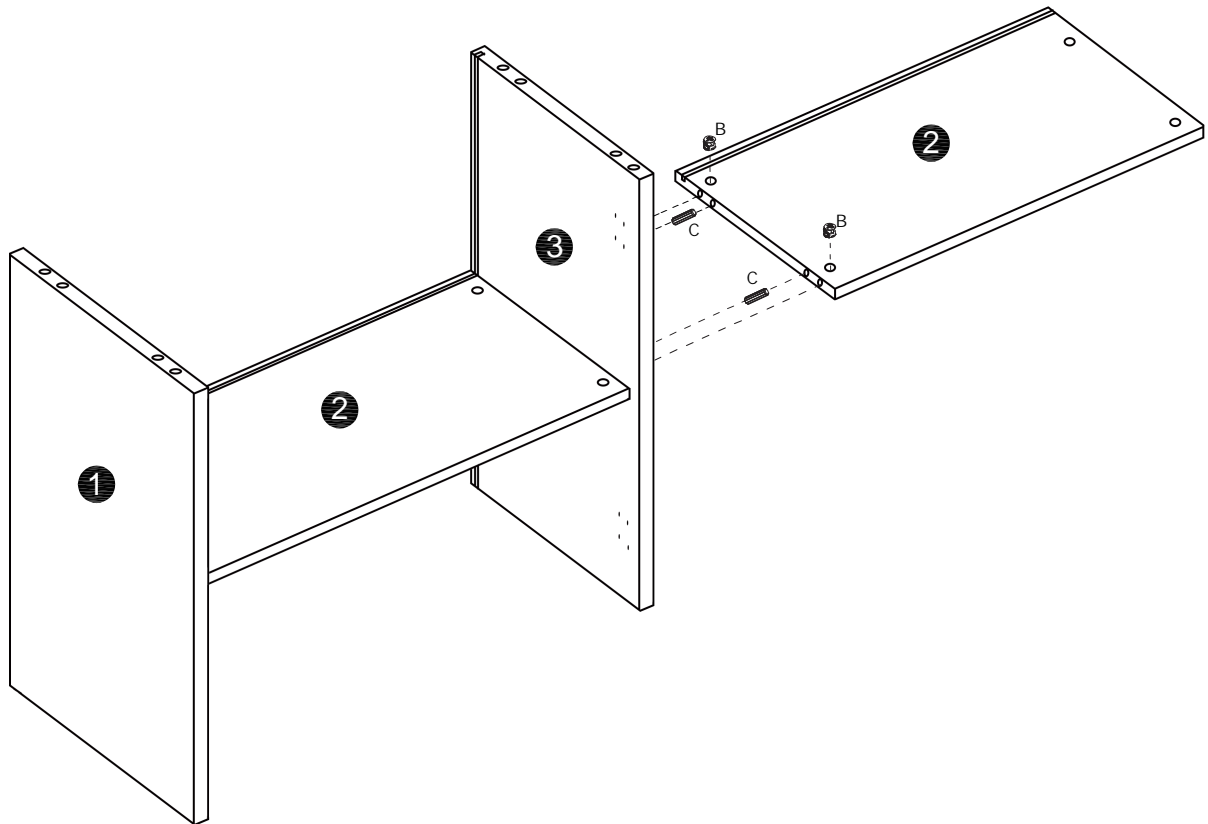

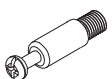

6

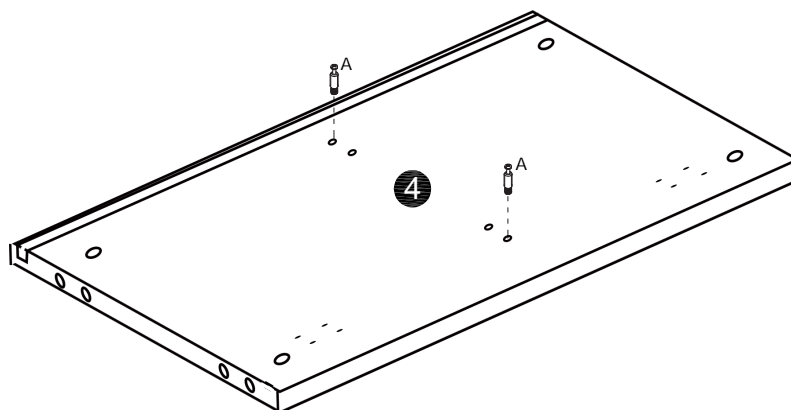
A

2 pcs

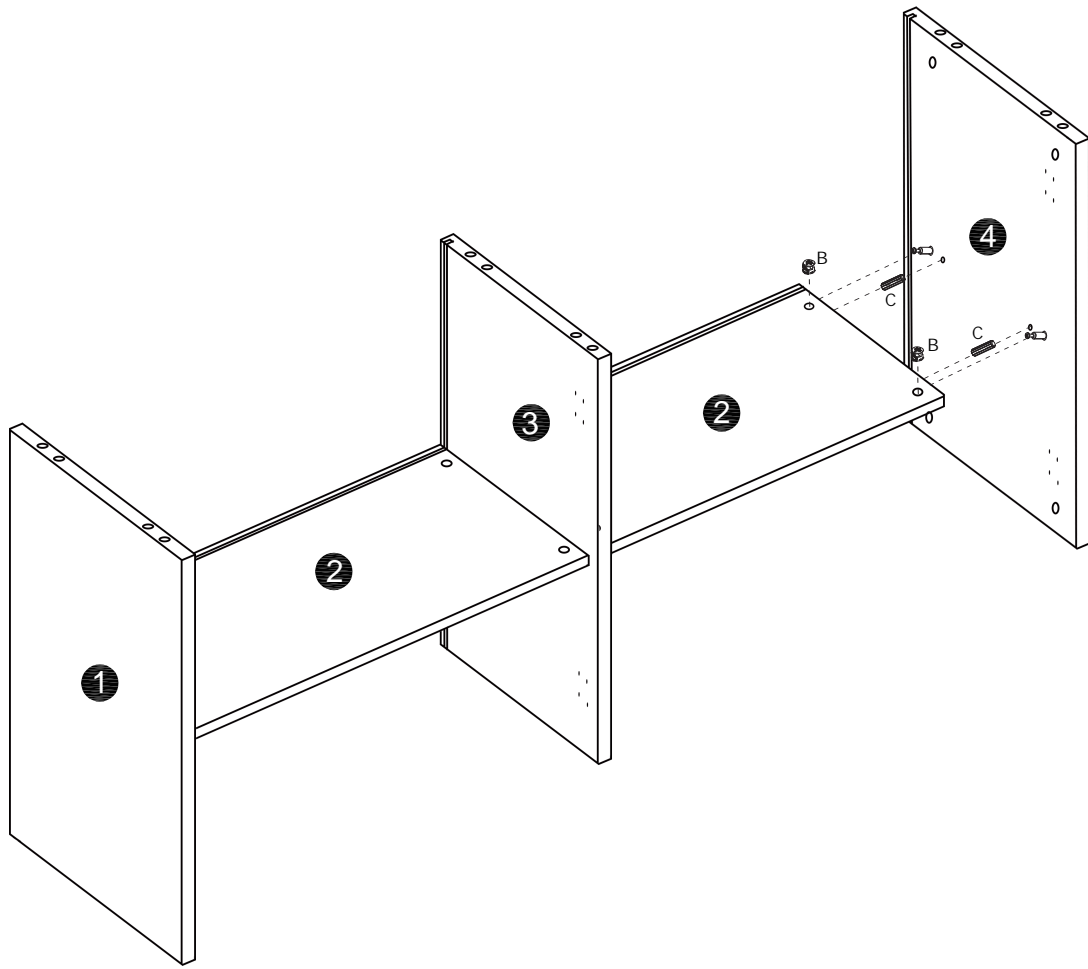

7



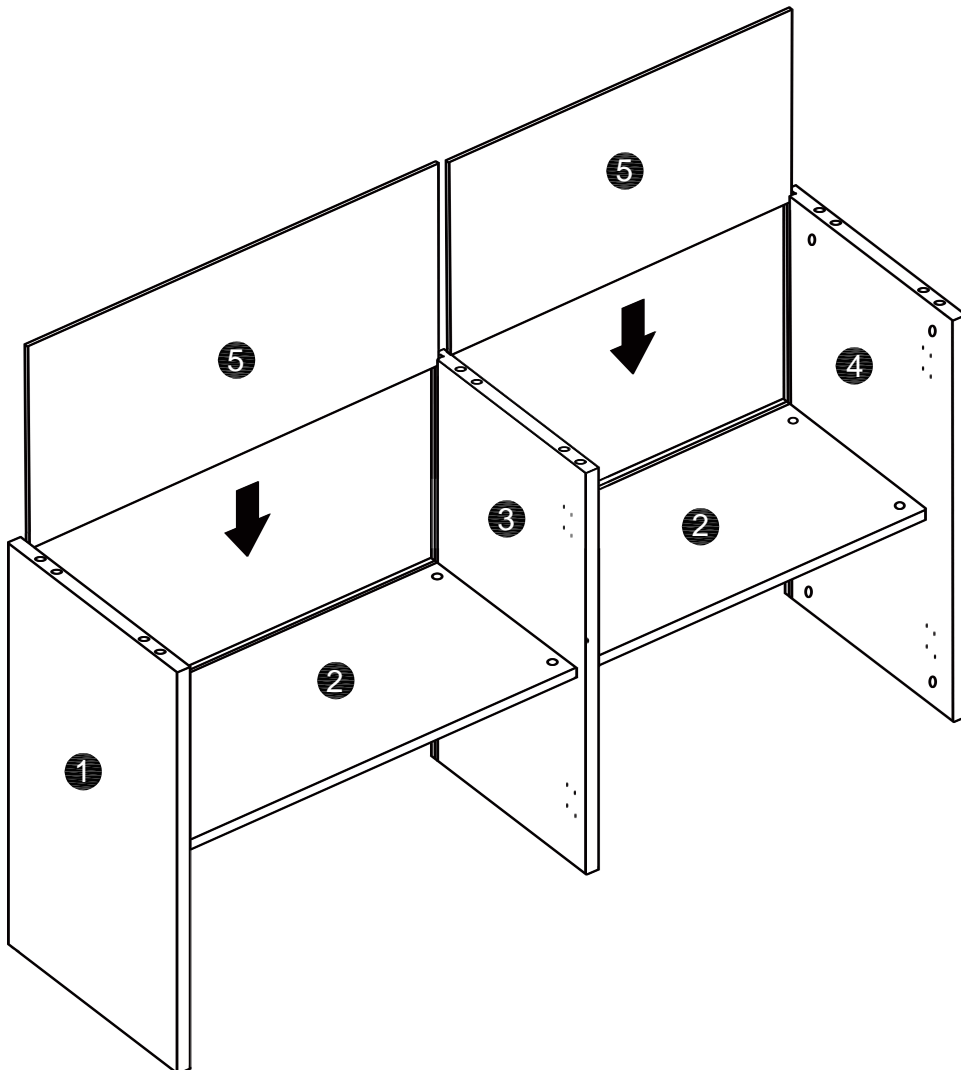

<b>B</b>

2 pcs
<b>C</b>

2 pcs

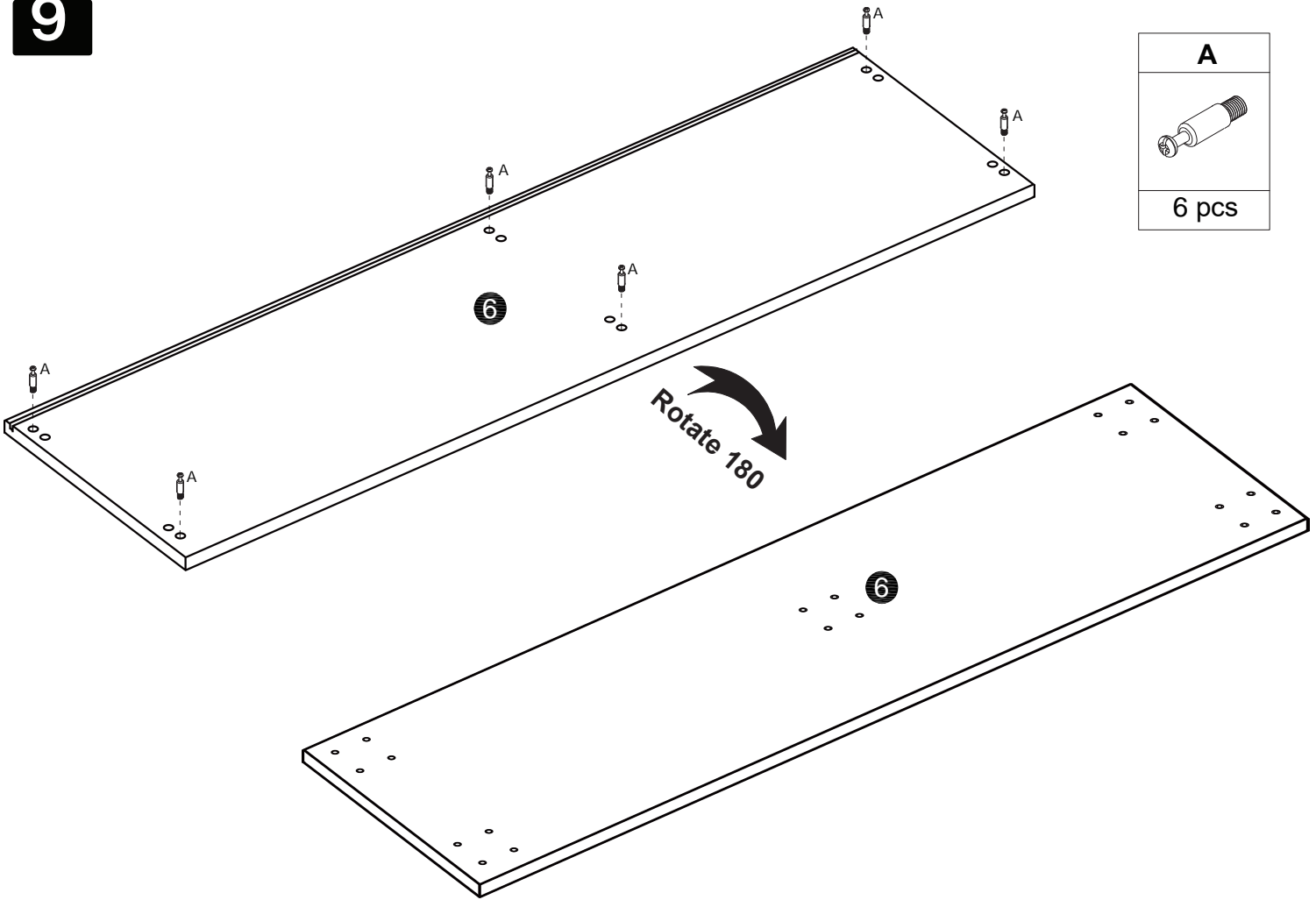
8





9

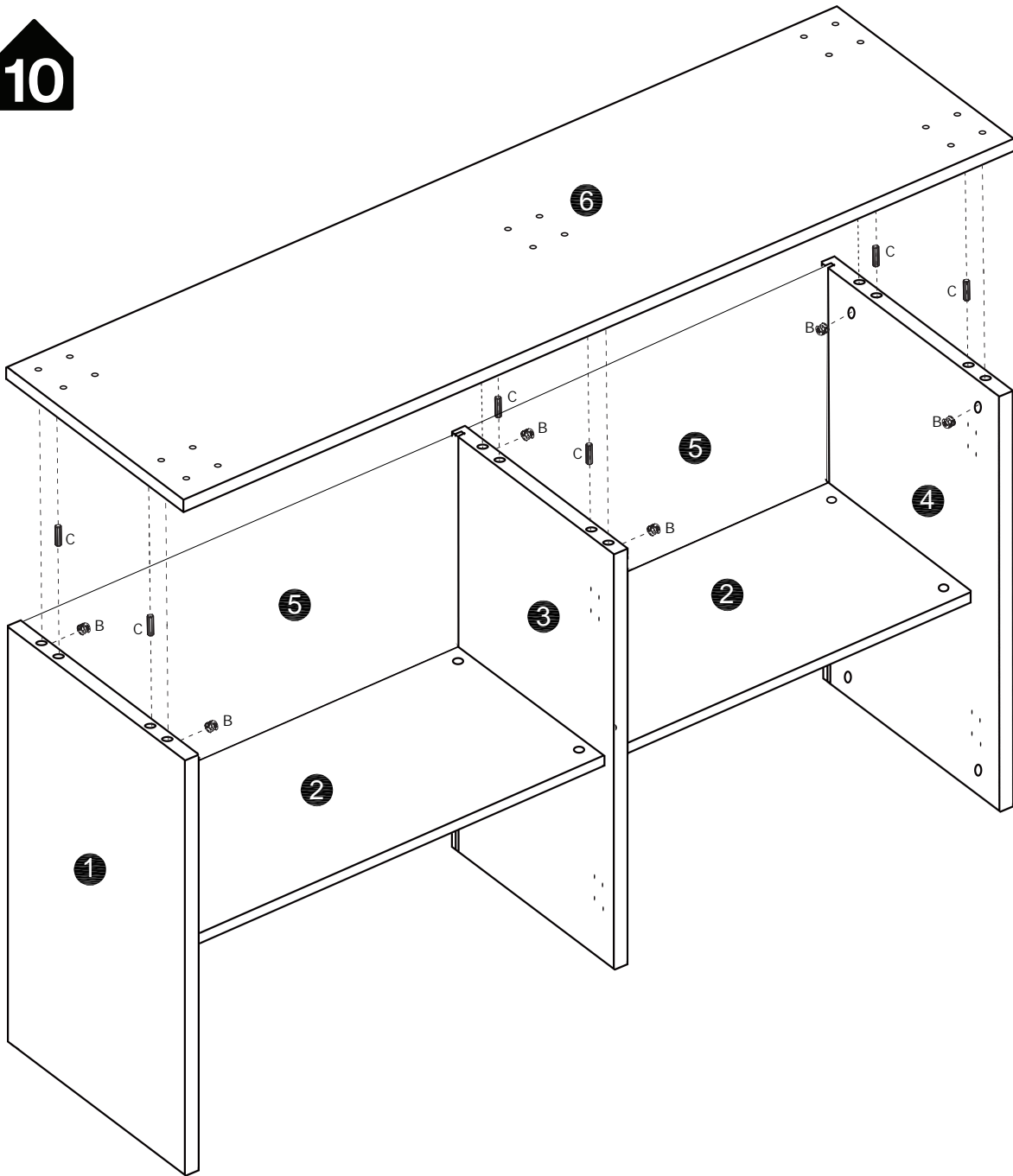

<b>A</b>

6 pcs

10

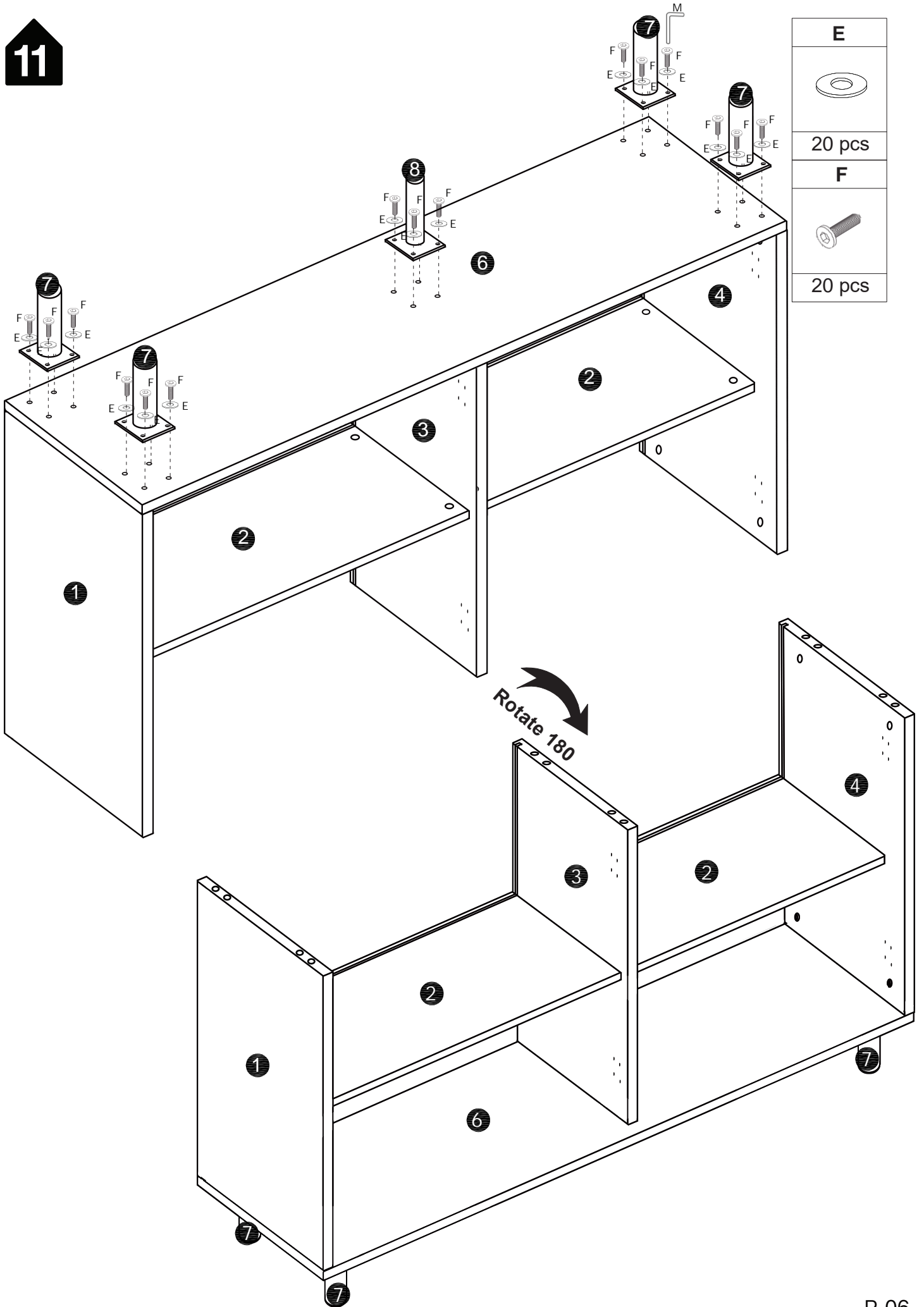

<b>B</b>

6 pcs
<b>C</b>

6 pcs

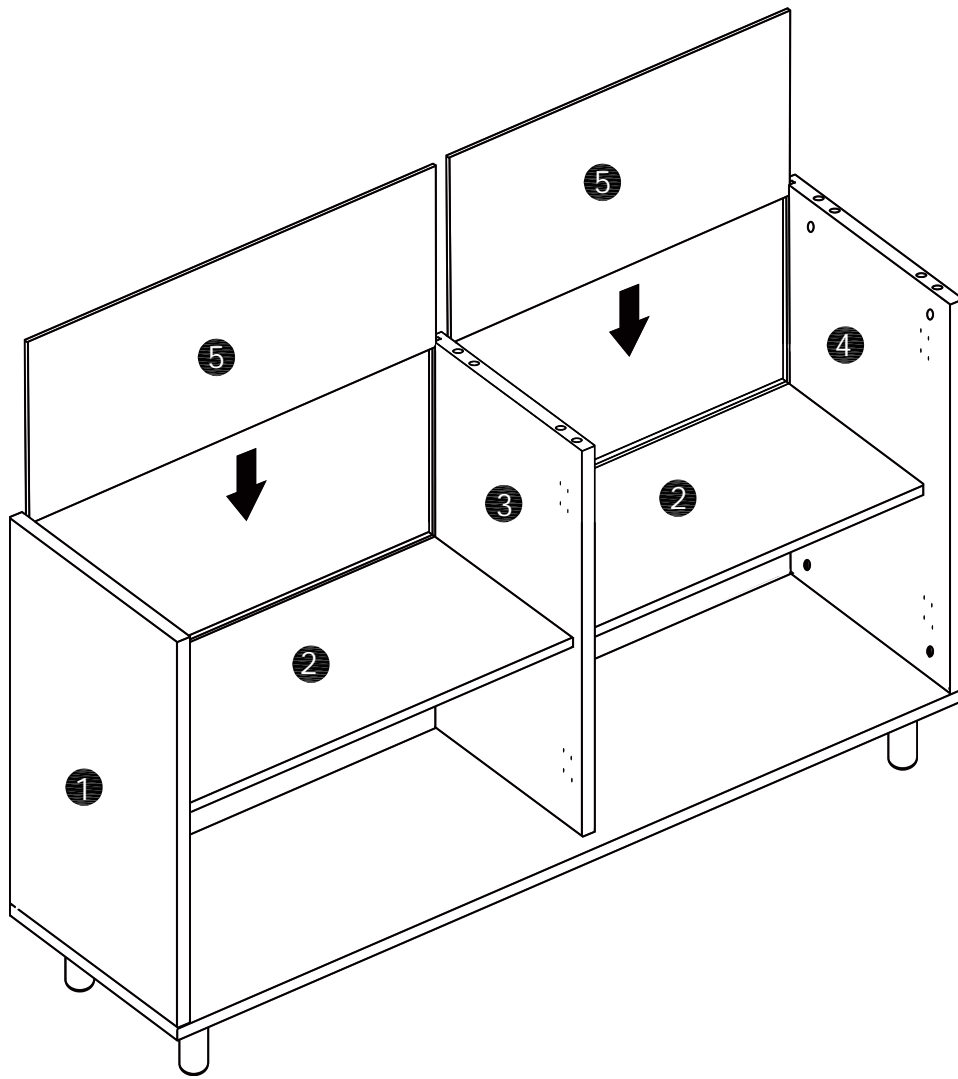

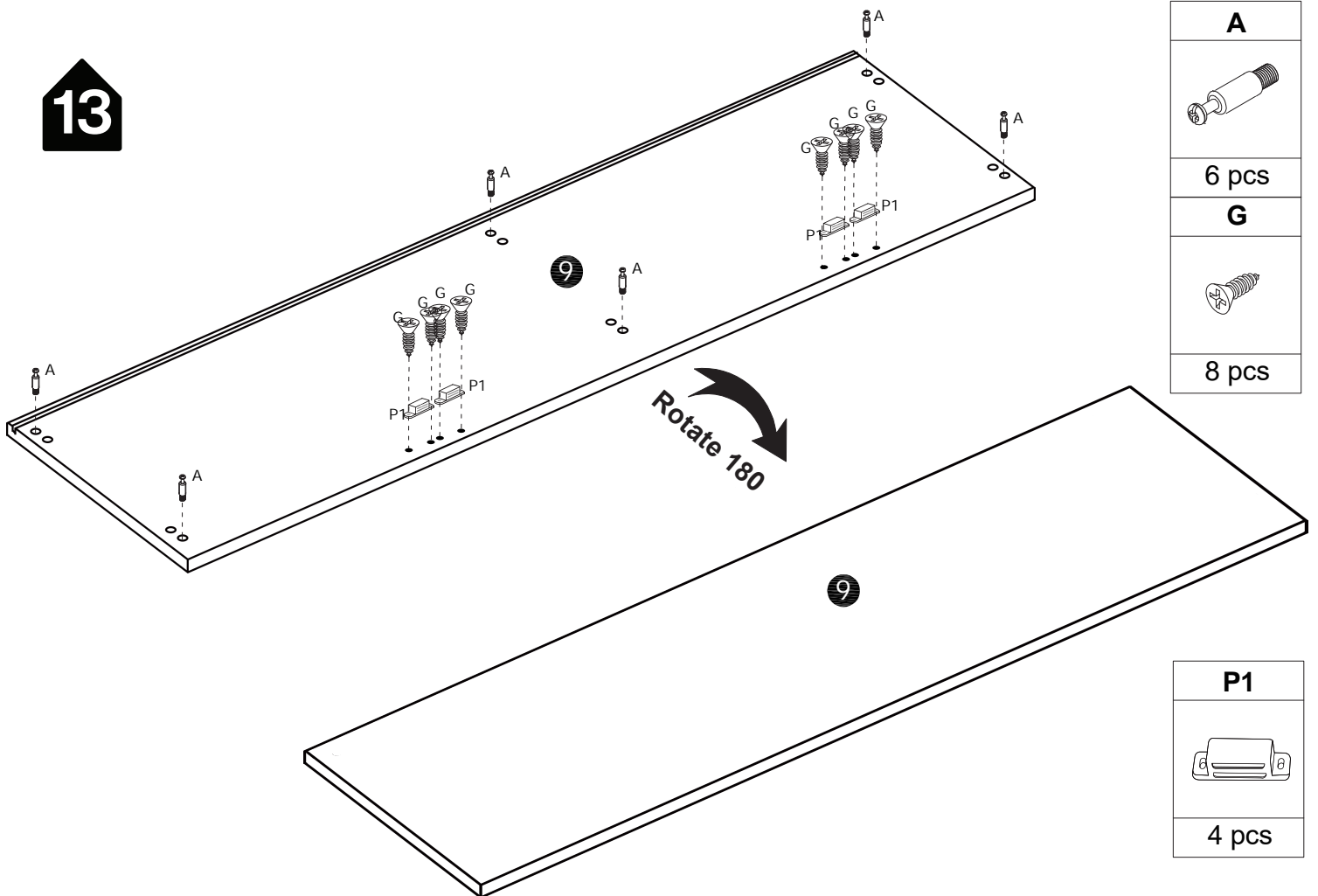

12



13

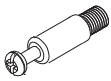



<b>A</b>

6 pcs
<b>G</b>

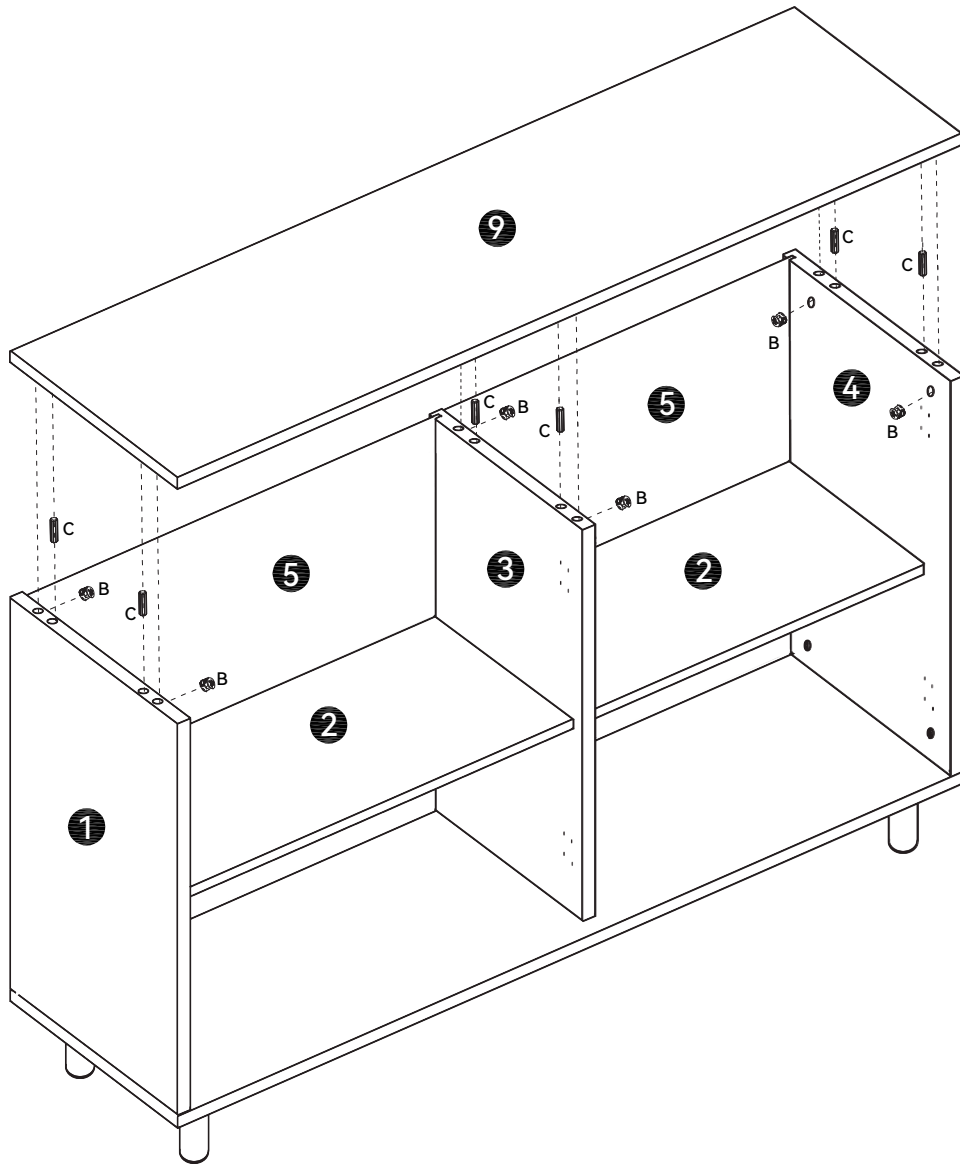
8 pcs

<b>P1</b>

4 pcs





14

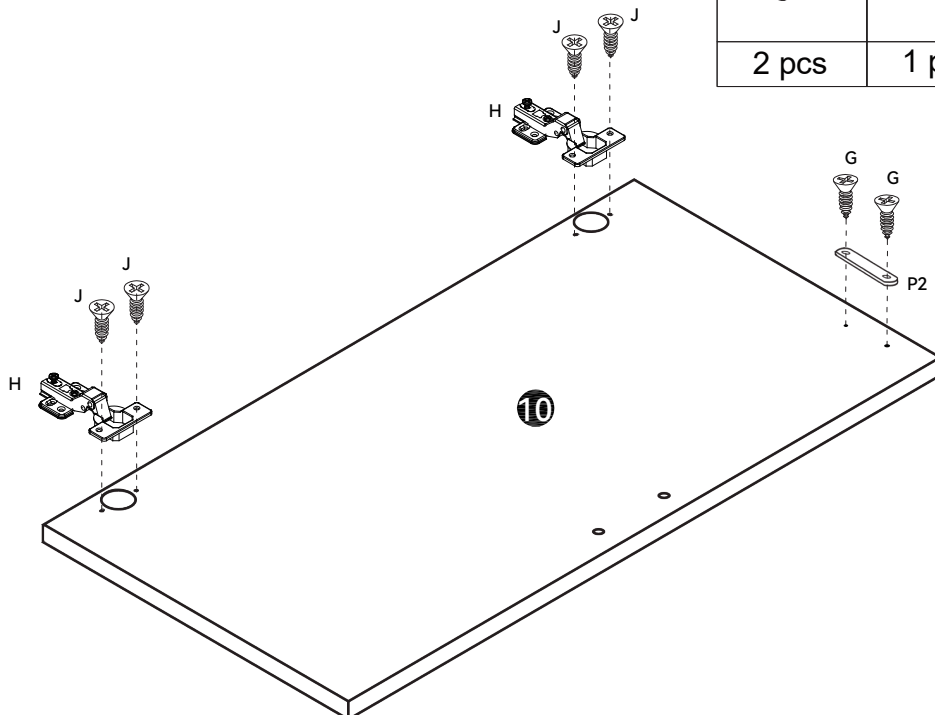



<b>B</b>

6 pcs
<b>C</b>

6 pcs

15

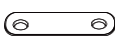

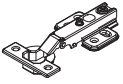

<b>G</b>	<b>P2</b>	<b>J</b>	<b>H</b>
			
2 pcs	1 pc	4 pcs	2 pcs

16

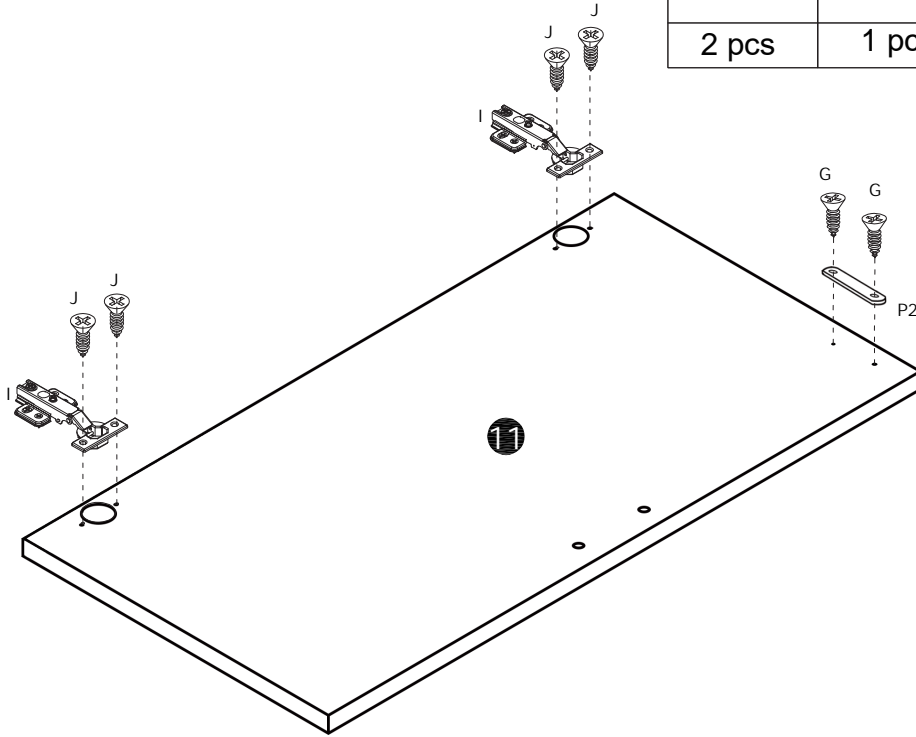
G	P2	J	I
			
2 pcs	1 pc	4 pcs	2 pcs



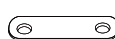

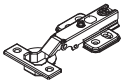
17

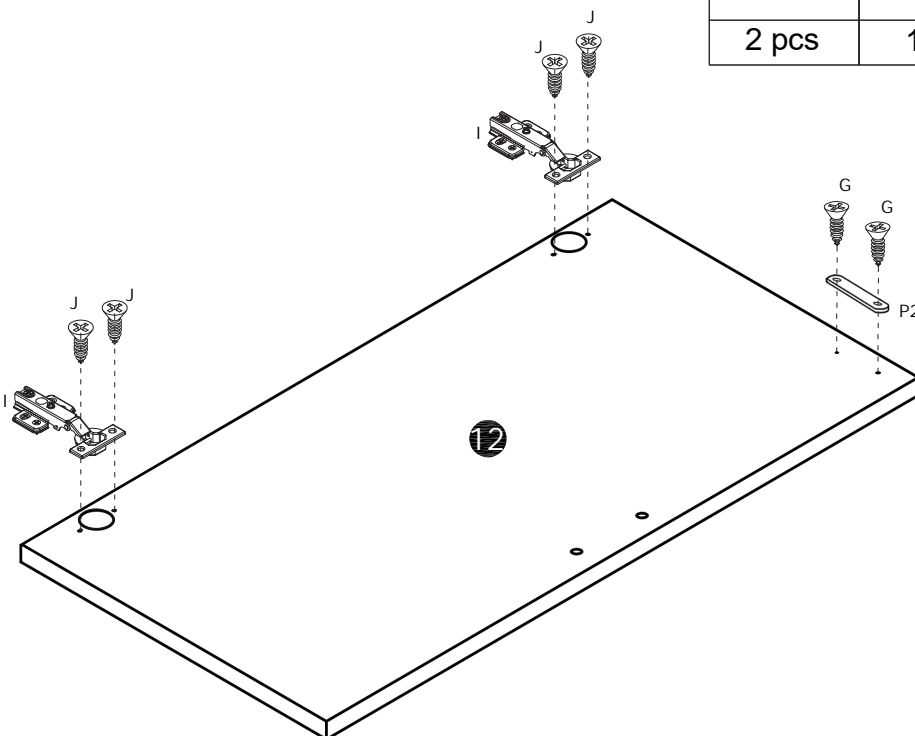
G	P2	J	I
			
2 pcs	1 pc	4 pcs	2 pcs



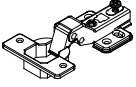

**18**

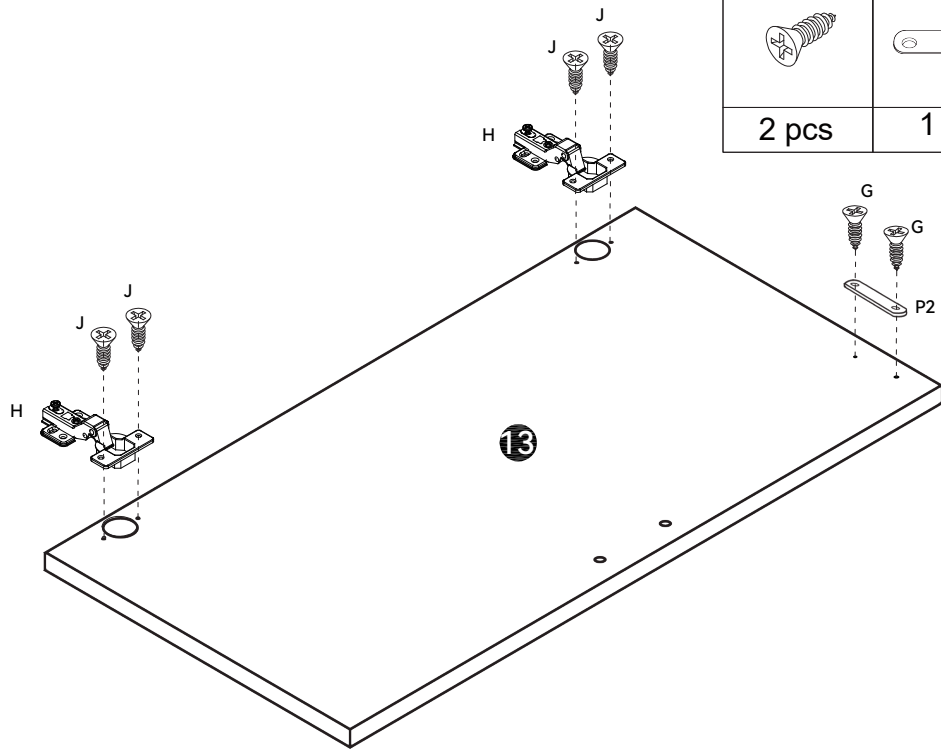
G	P2	J	H
			
2 pcs	1 pc	4 pcs	2 pcs



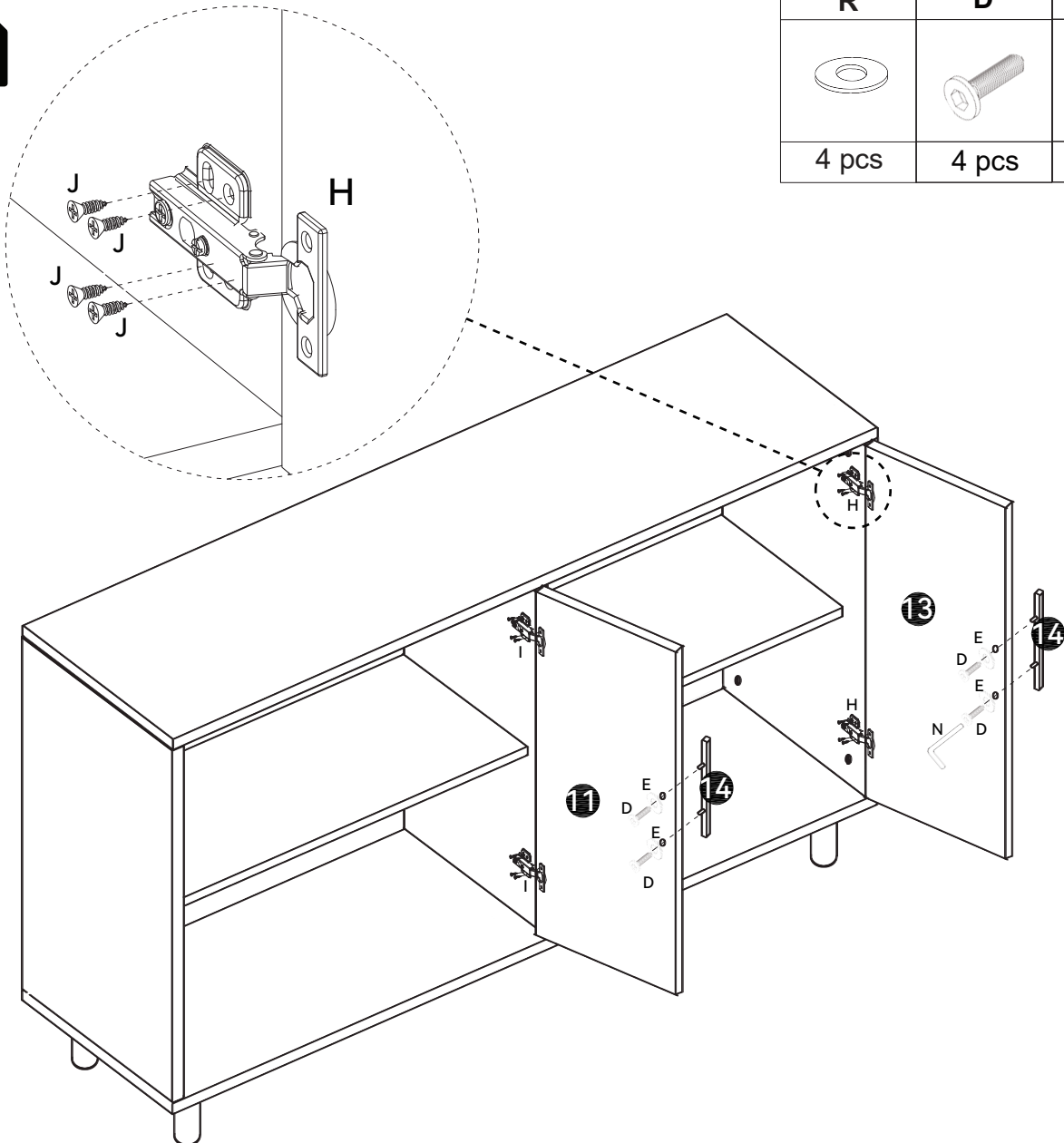

**19**

R	D	J
		
4 pcs	4 pcs	16 pcs

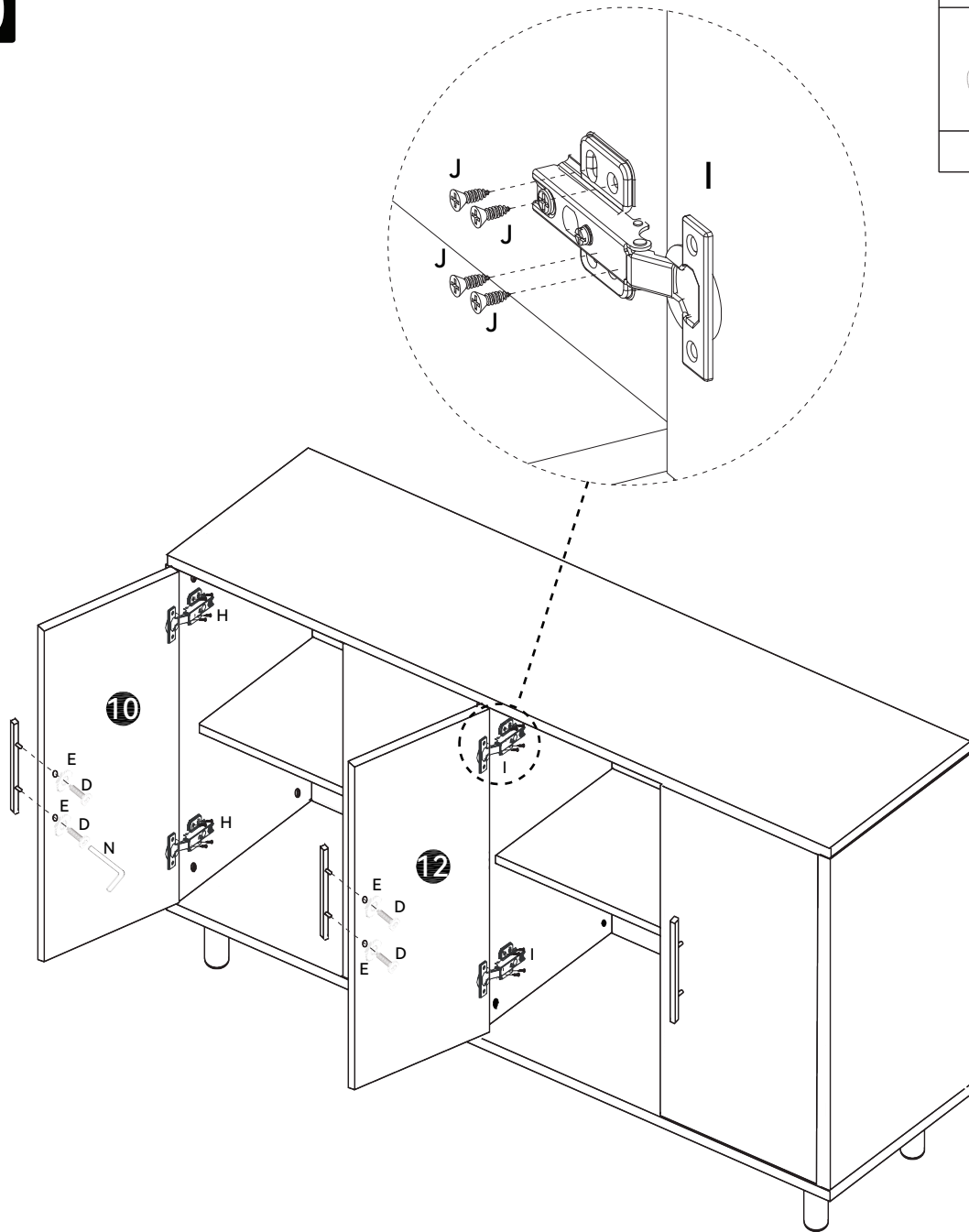



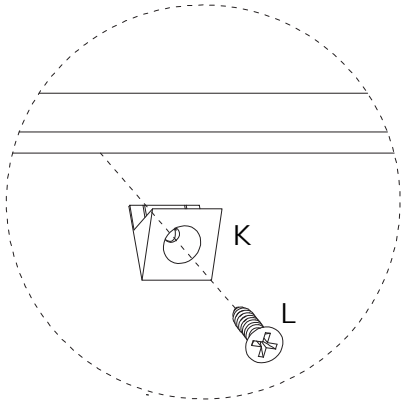

<b>D</b>	<b>J</b>
	
4 pcs	16 pcs
	<b>R</b>
	
	4 pcs

21

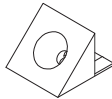

K	L
	
16 pcs	16 pcs

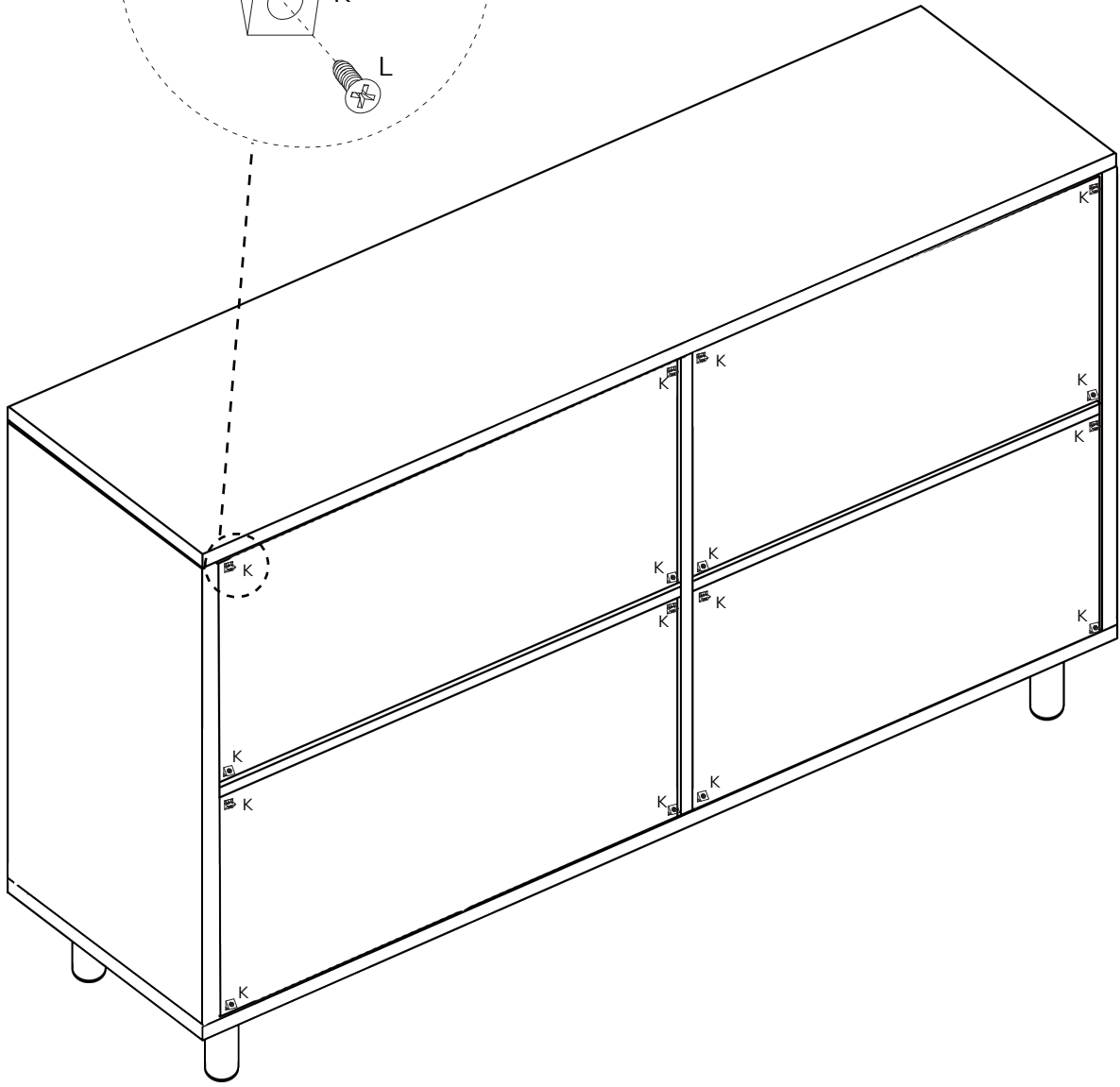

**Thank you for your support!**

