

Bed Instructional Guide & Sleep Book

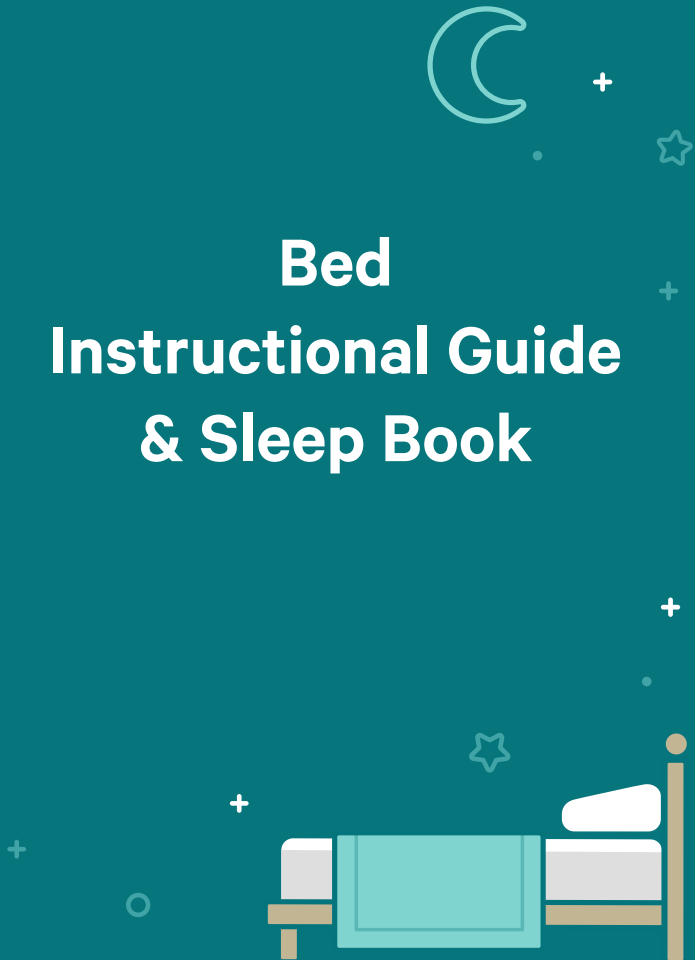

We're providing you with the necessary directions to easily and seamlessly set up your new Bed as well as some leisurely reading to help you settle in for your first night's sleep on your new set-up. Sweet dreams!

Contents

- 3** Mid-Century Bed Instructional Guide
- 17** A Bedtime Story
- 21** Sleep Facts
- 23** Notes from My Bed

Bed Instructional Guide Assembly Instructions

2 persons recommended for assembly.

All instructional elements and diagrams provided in this manual are to serve as a guide and are not meant to replace a licensed professional. Any construction or use of the product must be in accordance with all local zoning and/or building codes. The consumer is liable for all risk and responsibility associated with the assembly and construction of this product. The person or persons responsible for setting up this product should follow all safety instructions carefully as to not put themselves or any other parties at risk.



Read instructions, cover to cover



Have two adults on hand for assembly



Do not assemble on flooring or carpet











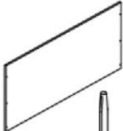

Assemble on a clean non-marring surface (packing foam)





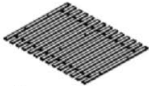













Save all packaging until finished

What's in the Box?

Label	Picture	Description	QTY
A		Headboard	1
B		Right Leg	1
C		Left Leg	1
D		First Support Bar	1
E		Footboard	1
F		First Support Leg	2
G		Right Side Rail	1
H		Second Support Bar	2
I		Second Support Leg	6
J		Slat Frame	1
K		Left Side Rail	1

If any contents in the box are missing, please contact our support right away.

Label	Picture	Description	QTY
①		Washer (Ø8.5x18x2mm)	3
②		Spring Washer (Ø8.5x11x1.5mm)	3
③		Crescent Nut (30x15x8)	3
④		Lock Nut M8	3
⑤		Allen Wrench (Ø8x90mm)	3
⑥		Bolt (Ø6x 110mm)	5
⑦		Barrel Nut (Ø6x 13mm)	5
⑧		Bolt (Ø6x 25mm)	7
⑨		Bolt (Ø6x 30mm)	7
⑩		Bolt (Ø6x 60mm)	9
⑪		Bolt (Ø8x 20mm)	5
⑫		Screw (Ø4x 30mm)	7
⑬		Nut (Ø10x30mm)	3
⑭		Allen Key (K4)	2
⑮		Spanner (K13)	1
⑯		Screwdriver (not provided)	1

If any contents in the box are missing, please contact our support right away.

Assembly Preparation

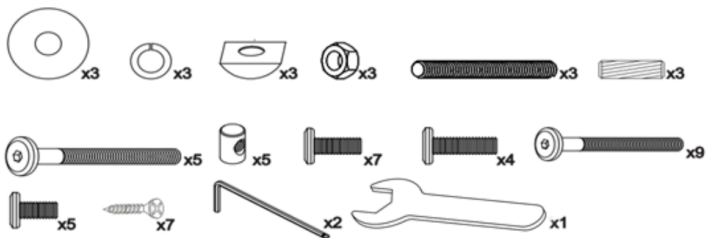
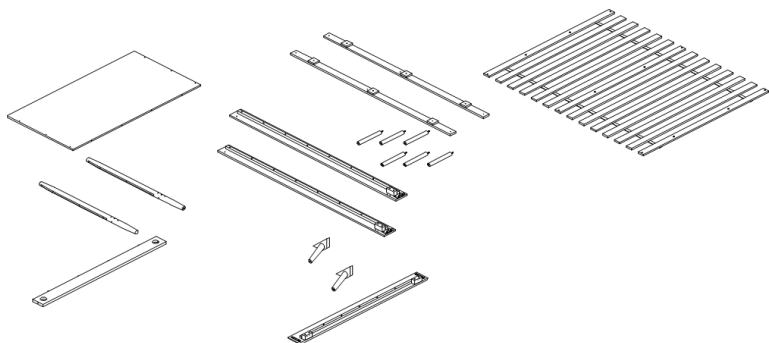

Now to the fun part!

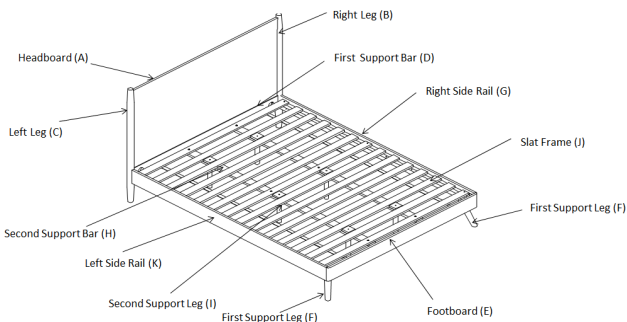

This Bed has multiple parts and may require up to some 30 minutes to assemble. To give you an overview of the Bed parts, the above picture is to help you put the various parts into perspective. Please read through the instructions below to familiarise yourself with the parts and steps before assembly.

Please follow the below steps carefully to ensure a proper assembly.

Step 1

Unpack and place all parts on a clean, non-marring surface.

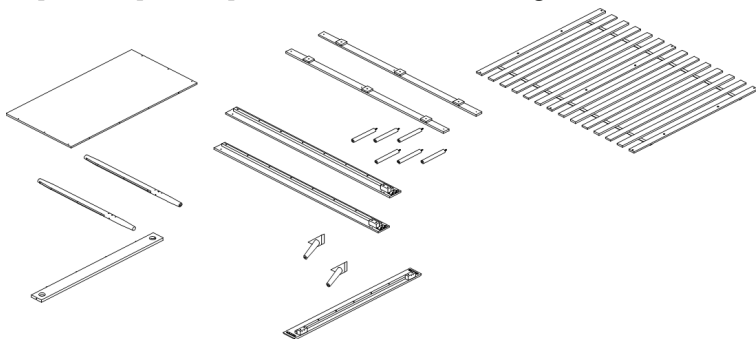

Step 2

- Insert the Allen Wrench (5) to the Right Leg (B) and Left Leg (C) as shown picture below

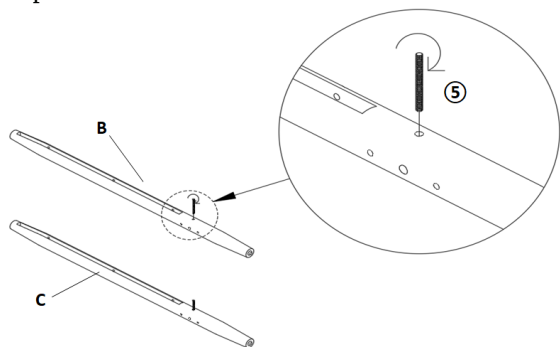

Step 3

- With assistance from your adult partners, carefully place the front side of the Headboard (A) facing up on a clean, non-marring surface as shown above. on a clean, non-marring surface as shown below.
- Attach Right Leg (B) and Left Leg (C) in step 2 to Headboard (A) and First Support Bar (D) by using Crescent Nut (3), Washer (1), Spring Washer (2), Lock Nut (4), Spanner (15).
- **Do not fully tighten the Nuts.**

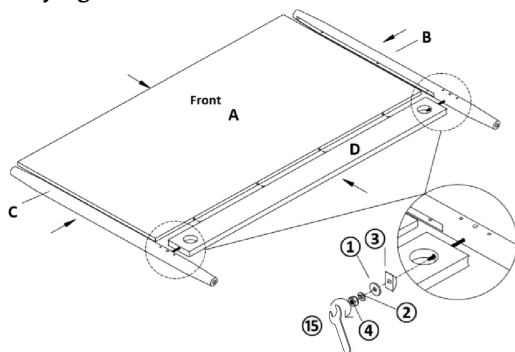

Step 4

- With the help of your adult partner, flip the assembled parts in step 3 to it's other side, then secure Right Leg (B) and Left Leg (C) to the Headboard (A) by Bolt (8) and Allen Key (14) as shown below.
- **Do not fully tighten the Bolts**

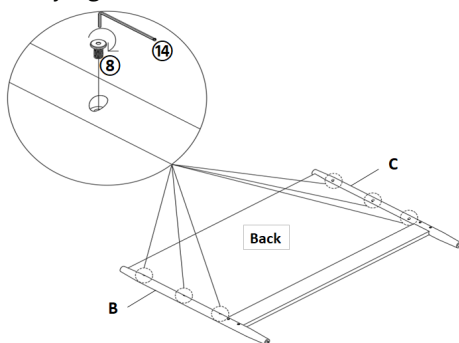

Step 5

- With the help of your adult partner, attach the assembled parts in step 4 to the Right Side Rail (G) by using Bolts (6), Barrel Nuts (7), Nut (13) and Allen Key (14)
- Repeat the same process with the Left Side Rail (K)
- **Do not fully tighten the Bolts**

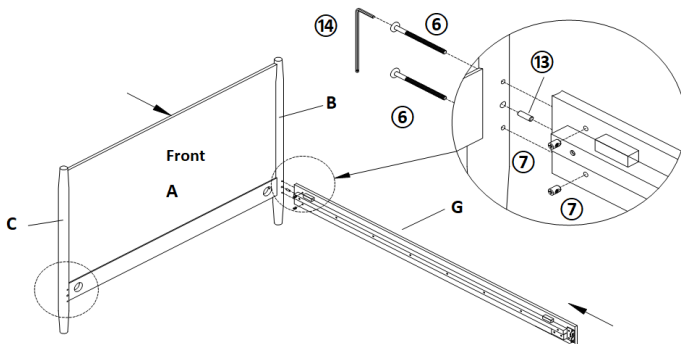

Step 6

- With the help of your adult partner, attach the First Support Leg (F) into Footboard (E) by using Bolt (10), Allen Key (14)
- Repeat the same process with the remain First Support Leg (F)
- **Do not fully tighten the Bolts**

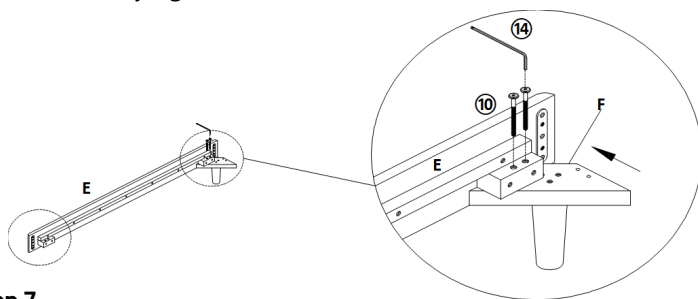

Step 7

- With the help of your adult partner, attach the assembled parts in step 6 into the assembled parts in step 5 by using Bolt (11), Allen Key (14) first, then Bolt (10), Allen Key (14) as shown below
- Repeat the same process with the remain
- **Do not fully tighten the Bolts**

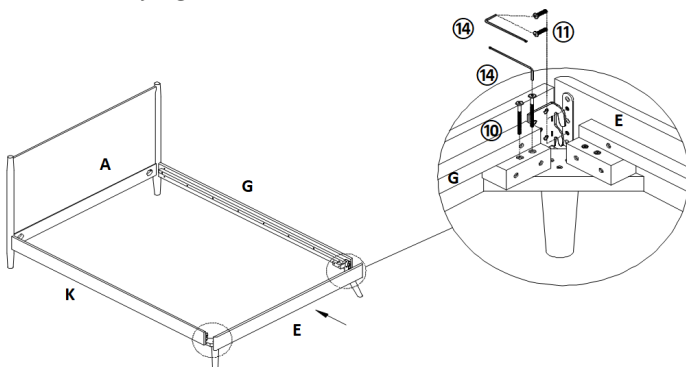

Step 8

- Attach the Slat Frame (J) into the Second Support Bar (H) by using Bolts (9) and Allen Key (14) as shown below.
- **Do not fully tighten the Bolts**

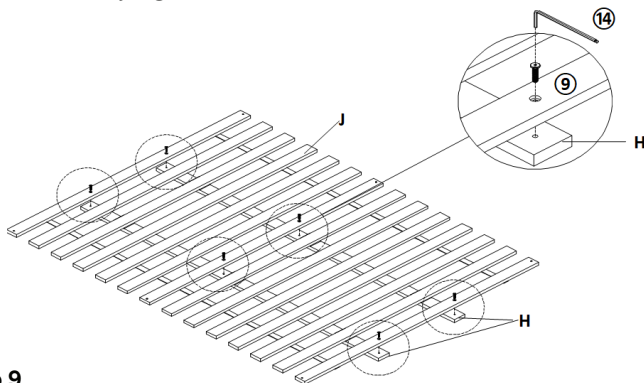

Step 9

- With the help of your adult partner, insert the Second Support Leg (I) into the assembled parts in step 8 as shown below.
- **Do not fully tighten the Bolts**

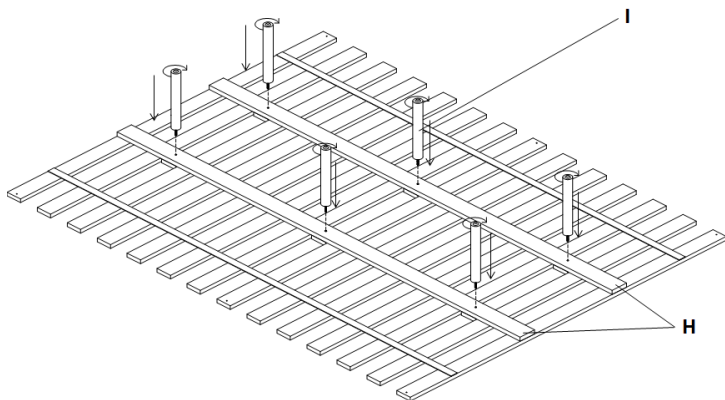

Step 10

- With the help of your adult partner, place the assembled parts in step 9 into the assembled parts in step 7

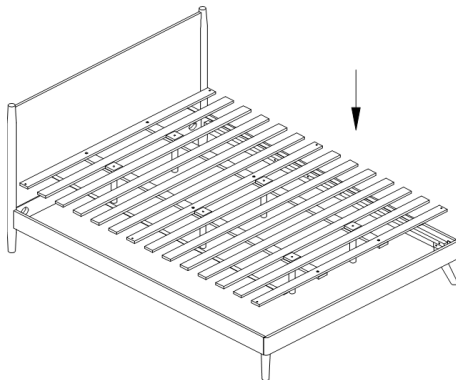

Step 11

- With the help of your adult partner, attach the Slat Frame (J) to the assembled parts in step 10 by using Screws (12) and Screwdriver (16) as shown below
- **Do not fully tighten the Screws**

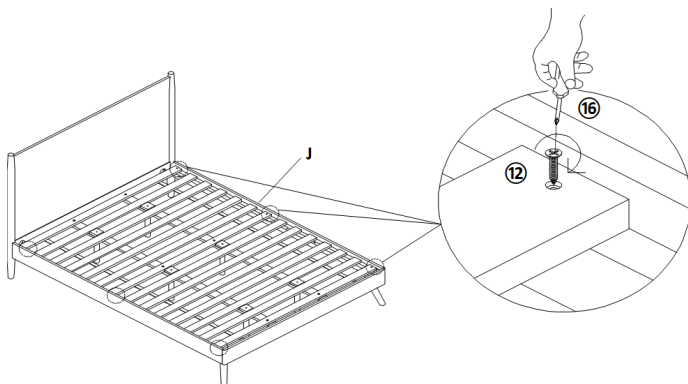

Step 12

- Check for wobbles.
- In a sequential manner, gradually tighten all Bolts until evenly secured.
- **Inspect the Bed and make sure all parts are adequately connected**
- With assistance from your adult partners, adjust the levelers to desired height to avoid wobbles.
- To adjust the Levelers, get assistance from an adult partner to lift/lean and hold the Bed while you are working.

Your Bed is ready for use.

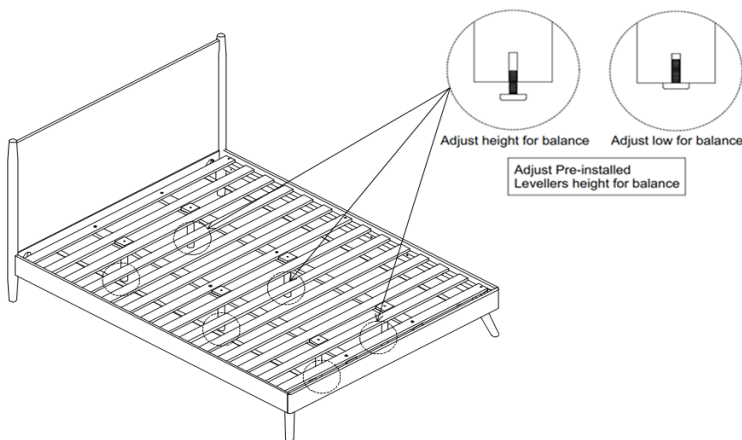

****Please note: this Bed can only be used on a flat, level surface.**

If additional help is needed in the assembly process, please reach out to our customer support team.

Care & Maintenance for your new Bed



Do not put hot items directly on furniture surface.



Do not clean furniture with harsh cleansers or polish.



Do not place furniture near heating or cooling vents.



Not for commercial use. For residential use only.



Stains may be removed with mild soap solution and damp cloth.



Dust and pick-up spills using a clean, non-colored, lint-free cloth.

Congrats on a job well done.

Congratulations on completing your new set-up!

While we know this was no small feat, we also bet it was pretty fun and rewarding. If you're not feeling completely rewarded and maybe still a little defeated, let us try to help you out by providing some light reading material to inspire, educate, or just make you laugh.

Enjoy & rest easy.

The Sleep Guide

Sleep Facts

A list of fun and surprising facts about sleep.

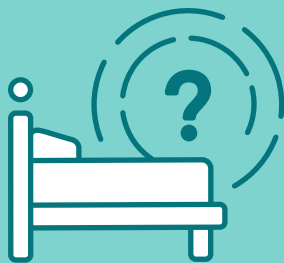

- Only 21% of Americans get the recommended 7 to 8 hours of sleep each night.
- Humans are the only mammals that delay sleep.
- The average person falls asleep in 7 minutes.
- 60% of American adults experience sleep problems at some time.
- Insomnia is the most common sleep disorder.
- Women sleep more than men.
- One sleepless night affects your brain the same way as being drunk.
- When you're in REM sleep, your brain is almost as active as when you are awake.
- Got a problem? Sleep on it! REM sleep is proven to help creative problem-solving.

source: <https://www.thegoodbody.com/sleep-facts/>

Notes from my bed

A few fun, quirky
apology notes that
you can cut out, sign,
date, and give to
whomever you please.

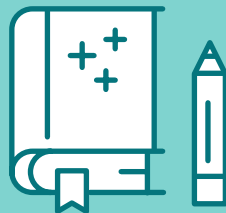

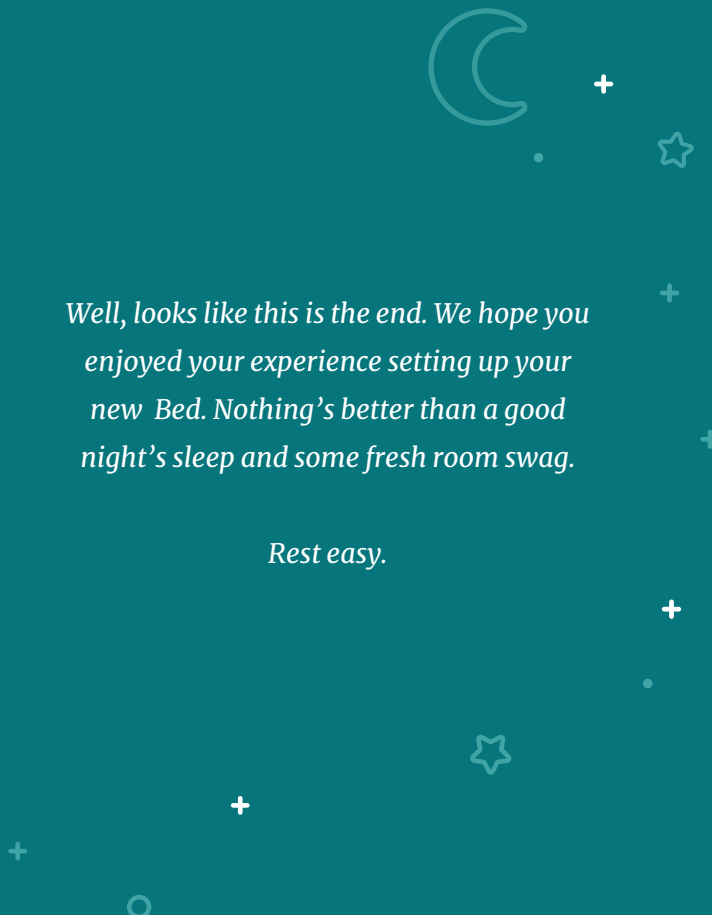
A decorative night sky background with various icons: a large crescent moon, a five-pointed star, a small dot, and several plus signs scattered across the teal background.

Well, looks like this is the end. We hope you enjoyed your experience setting up your new Bed. Nothing's better than a good night's sleep and some fresh room swag.

Rest easy.