

Fix the two desktops

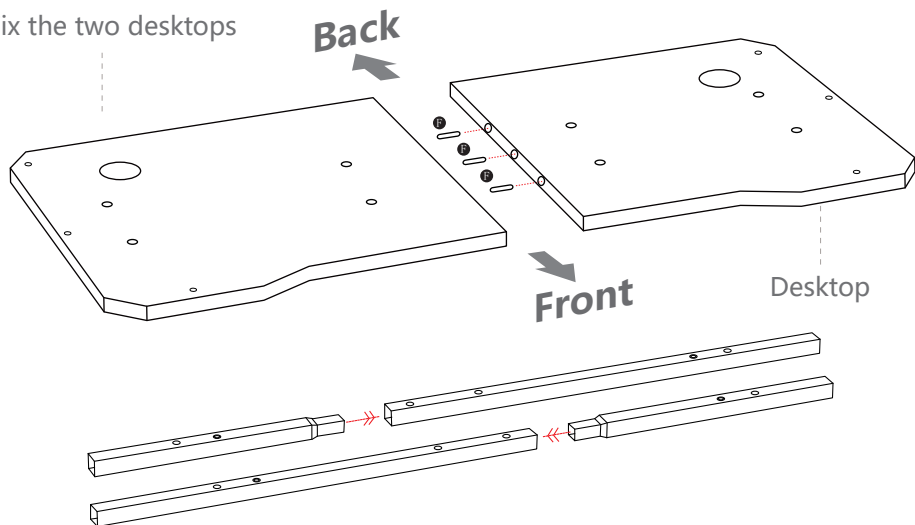

**!** Insert the short metal rod into the long metal rod.  
Please install as shown.

**B**  30mm\*8

 \*8

Bolt (30mm)

Washer

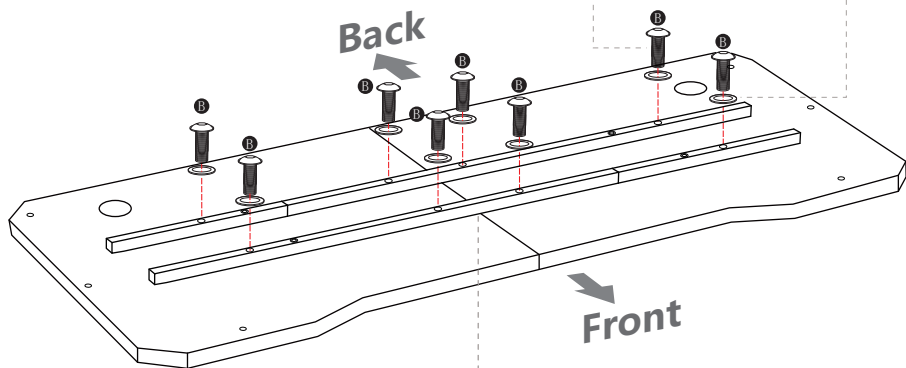

Attach the metal rod to the desktop

  35mm\*4

 \*4

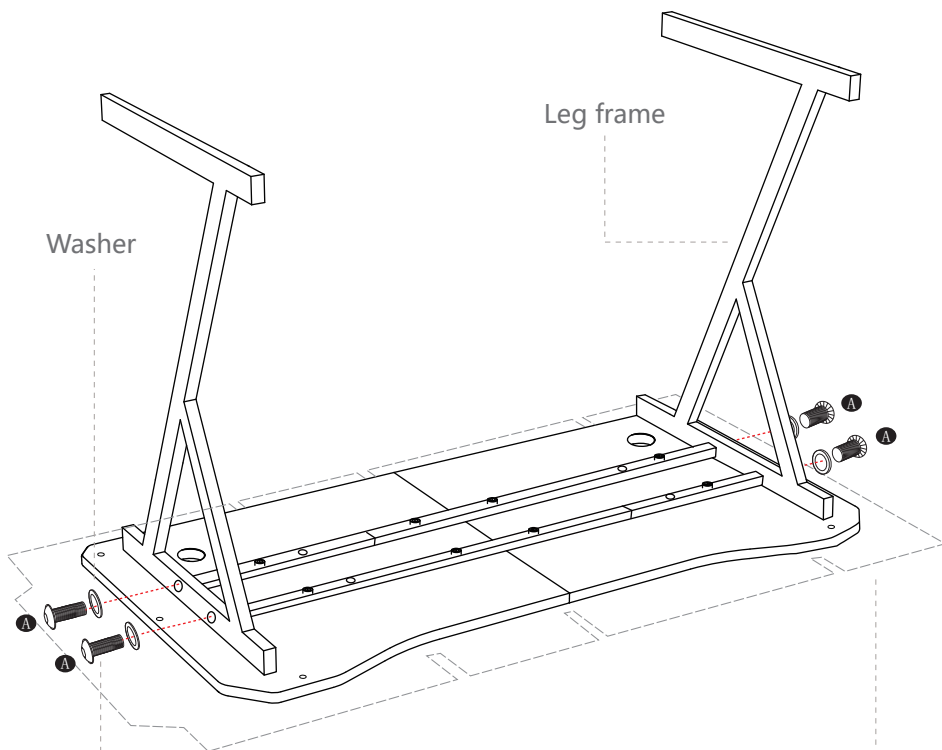

Bolt (35mm)

※ Please leave it a bit loose during installation.

You can lay the packaging box flat on the ground to use as padding, preventing direct contact between the desktop and the floor, which could cause wear.

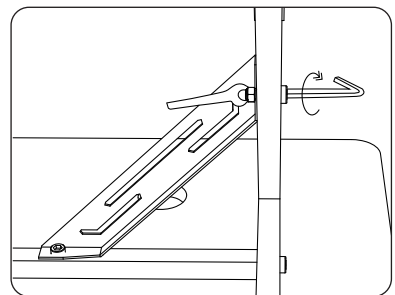
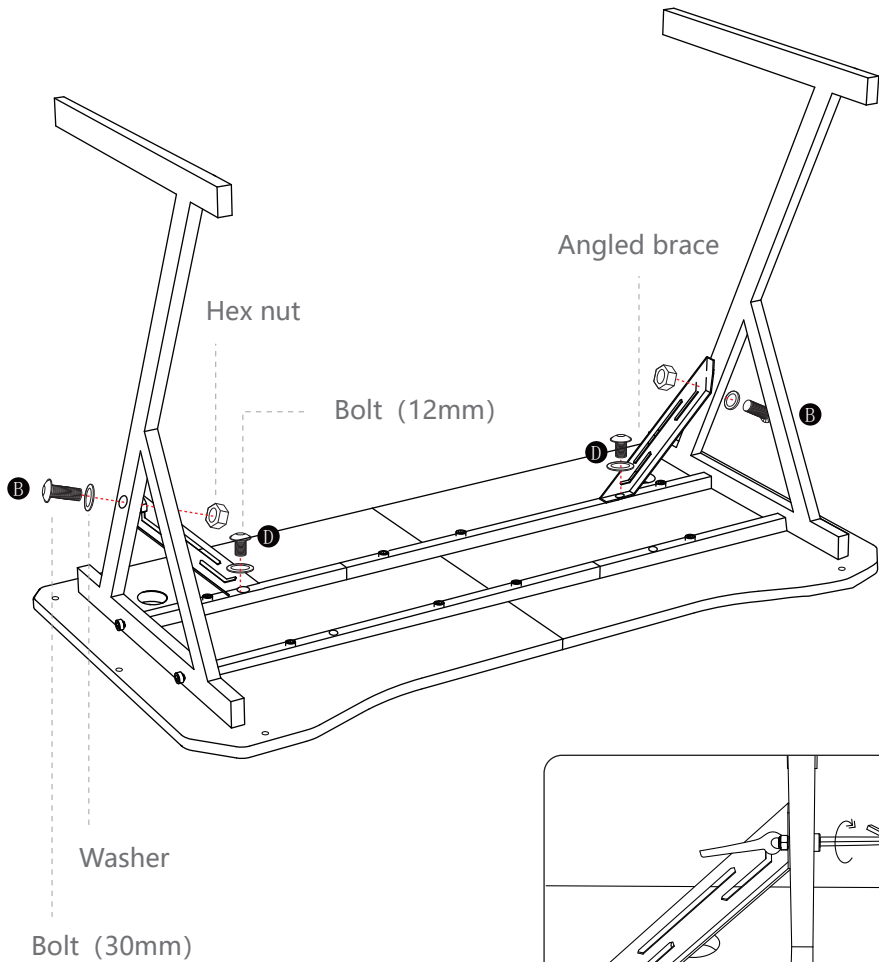
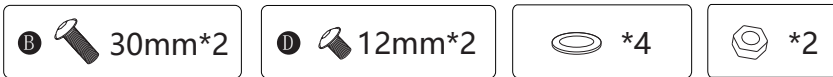

- Please do not tighten the screws too much during assembly. Be especially careful not to fully tighten all the screws until they are all in place.

①  12mm\*2

 \*2

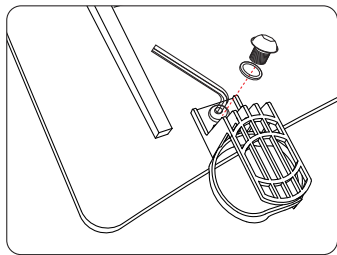
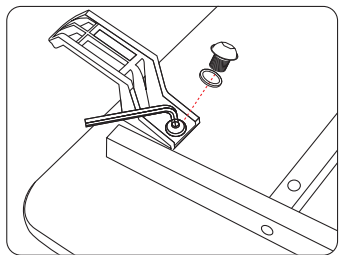
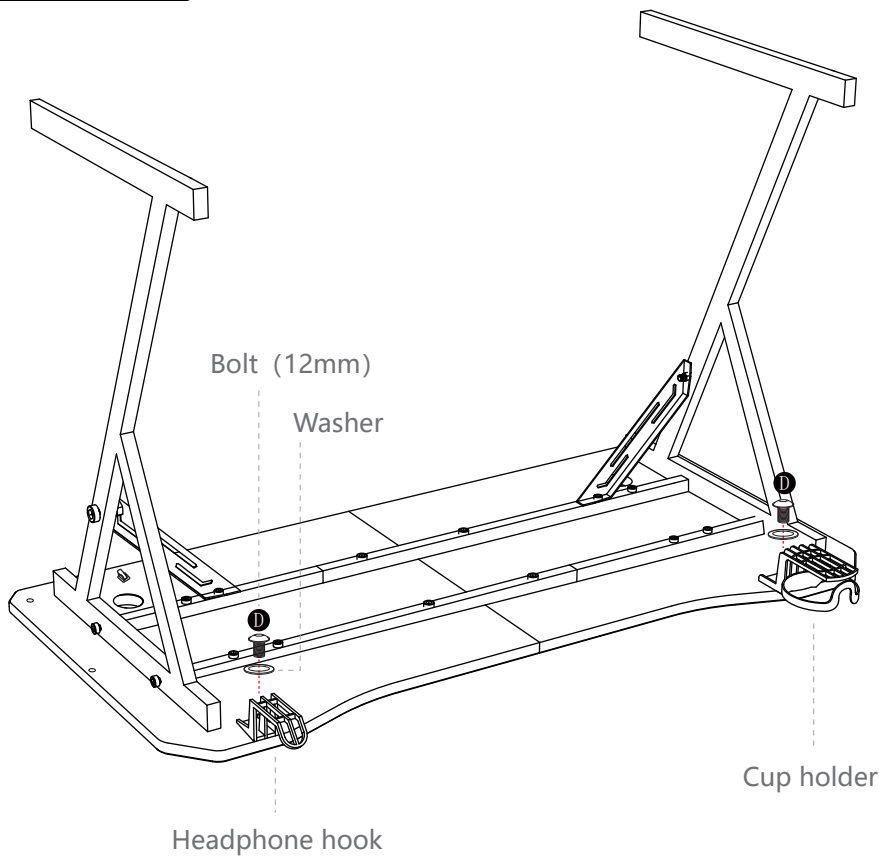

Install the cup holder and headphone hook.

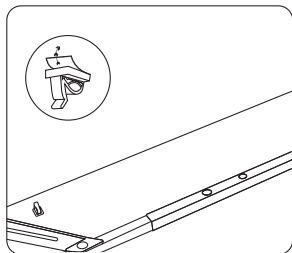
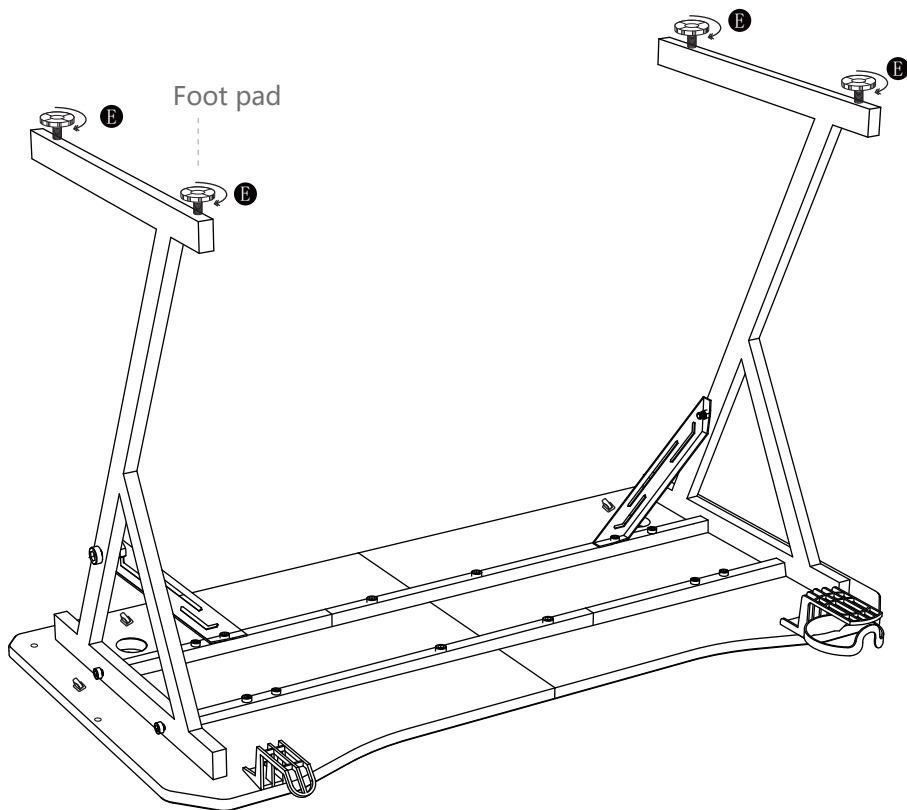
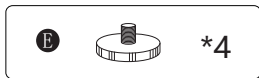

Install the foot pads.

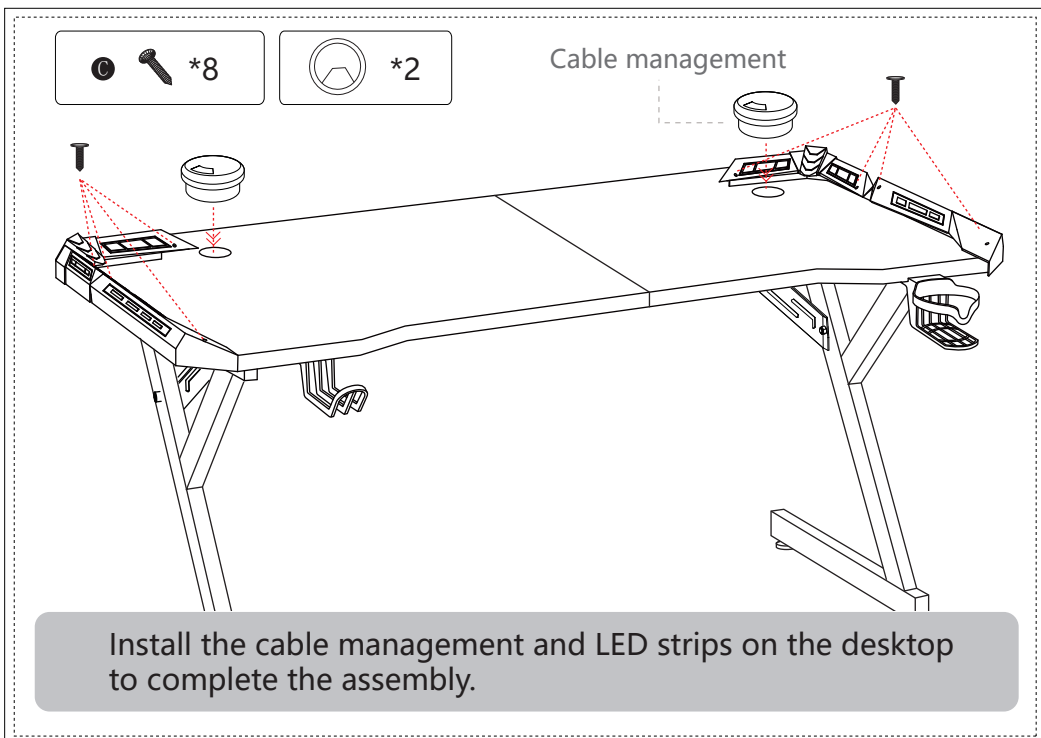
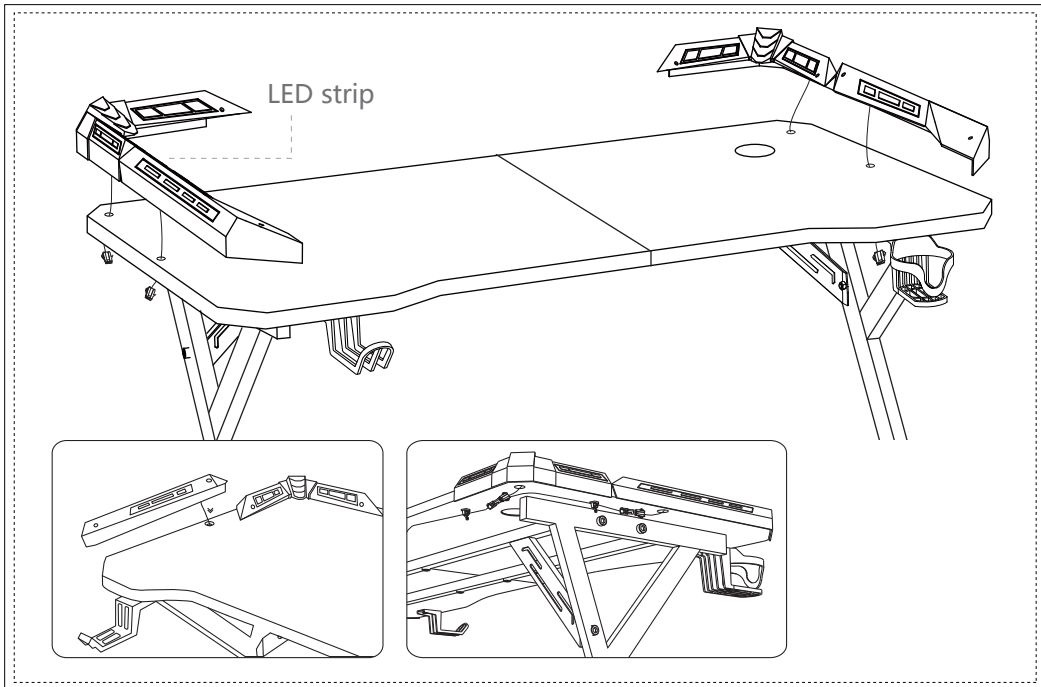

Die beiden Tischplatten  
befestigen

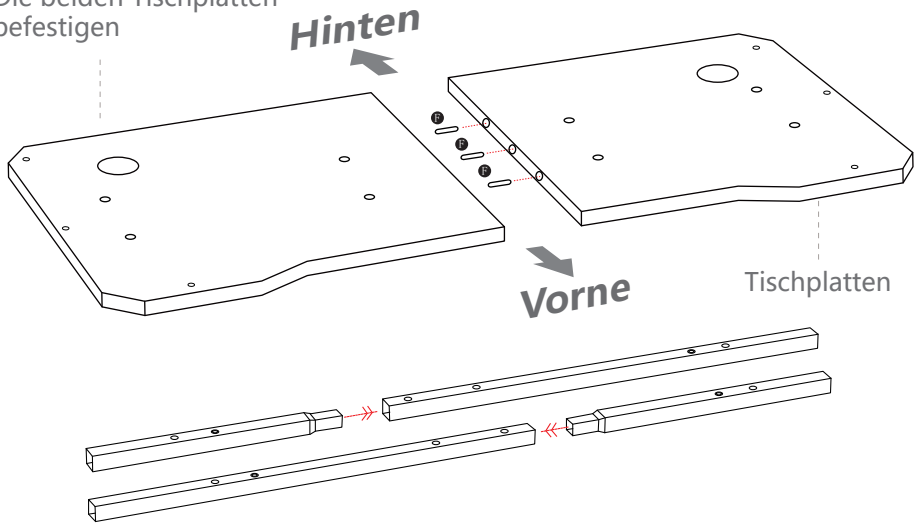

**!** Stecken Sie die kurze Metallstange in die lange Metallstange.  
Installieren Sie es wie im Diagramm gezeigt.

**B**  30mm\*8

 \*8

Bolzen (30mm)

Unterlegscheibe

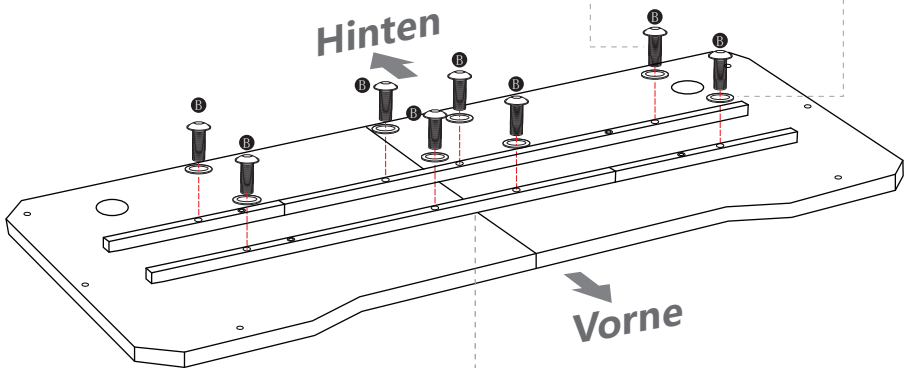

Verstärken Sie die  
Metallstange

Befestigen Sie die Metallstange  
an der Tischplatten.



35mm\*4



\*4

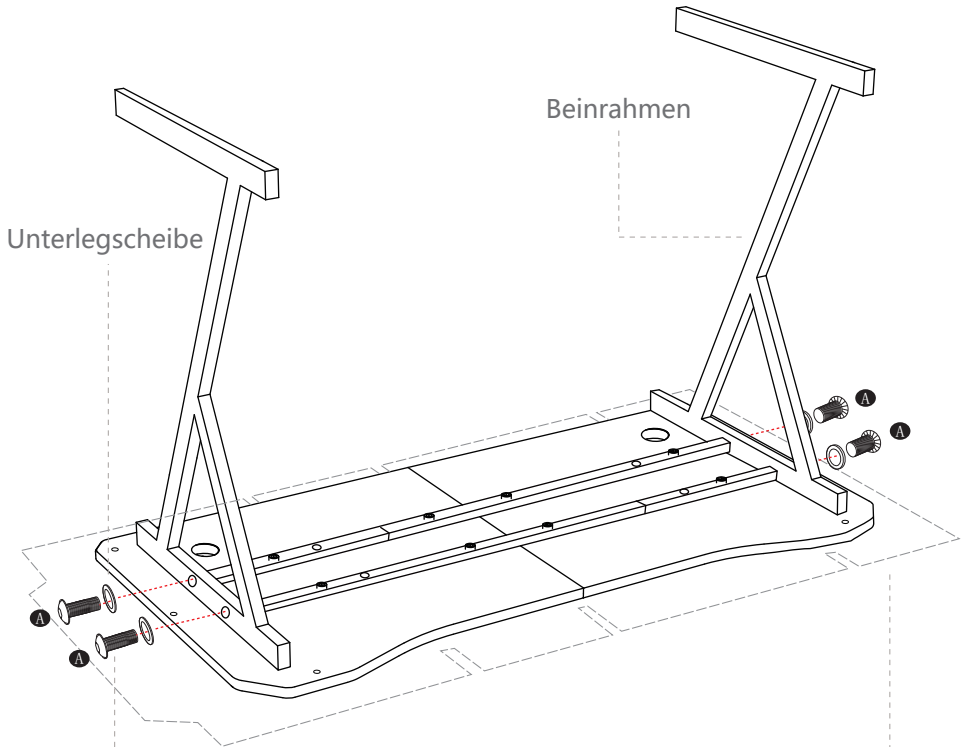

Bolzen (35mm)

※ Bitte lassen Sie es im montierten Zustand ein wenig locker.

Sie können den Karton flach auf den Boden legen und als Unterlage verwenden, um zu verhindern, dass die Tischplatte direkt mit dem Boden in Kontakt kommt und dadurch beschädigt wird.

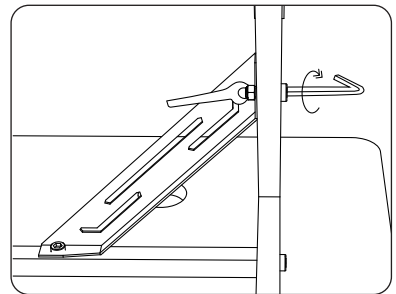
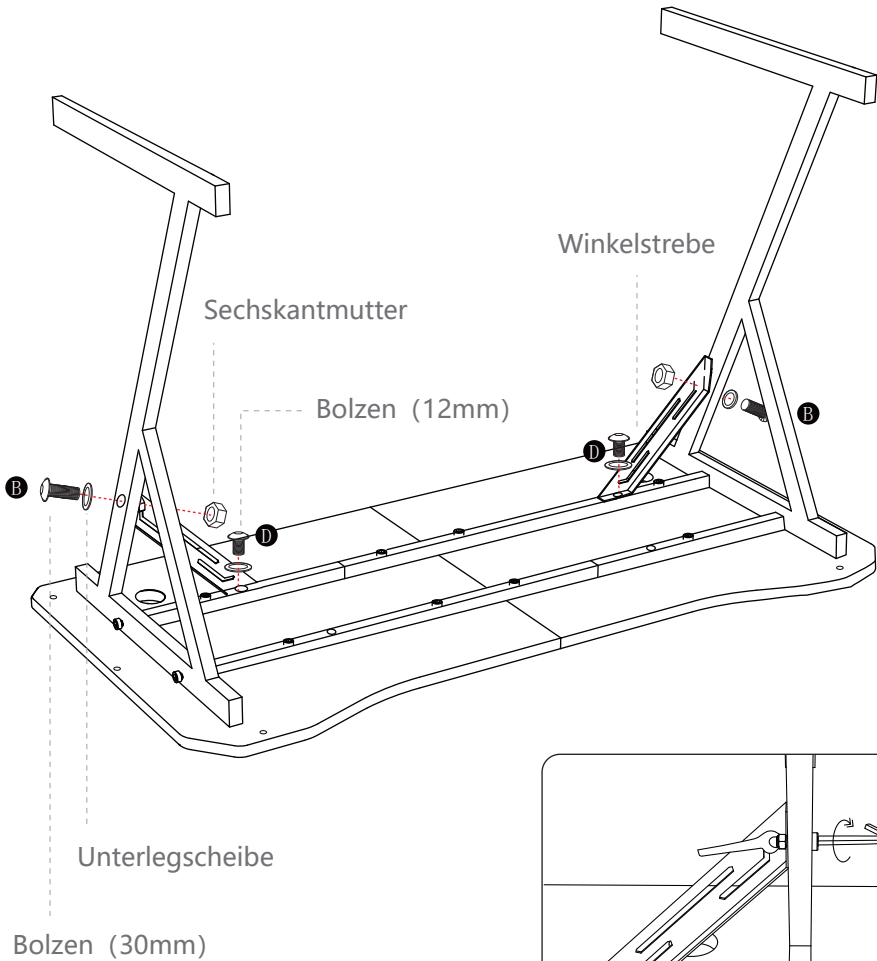
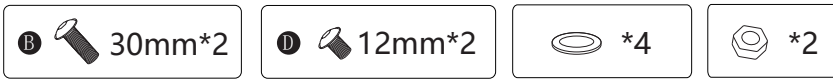

Bitte ziehen Sie die Schrauben während der Montage nicht zu fest an. Achten Sie besonders darauf, alle Schrauben nicht festzuziehen, bis sie an ihrem Platz sind.

①  12mm\*2

 \*2

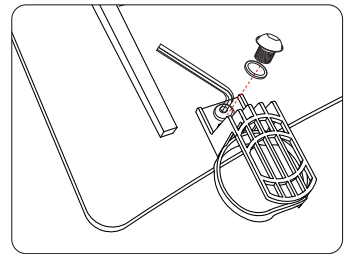
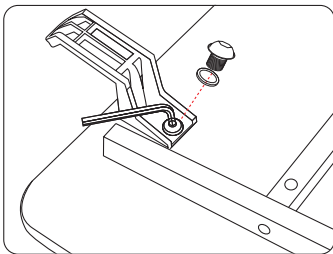
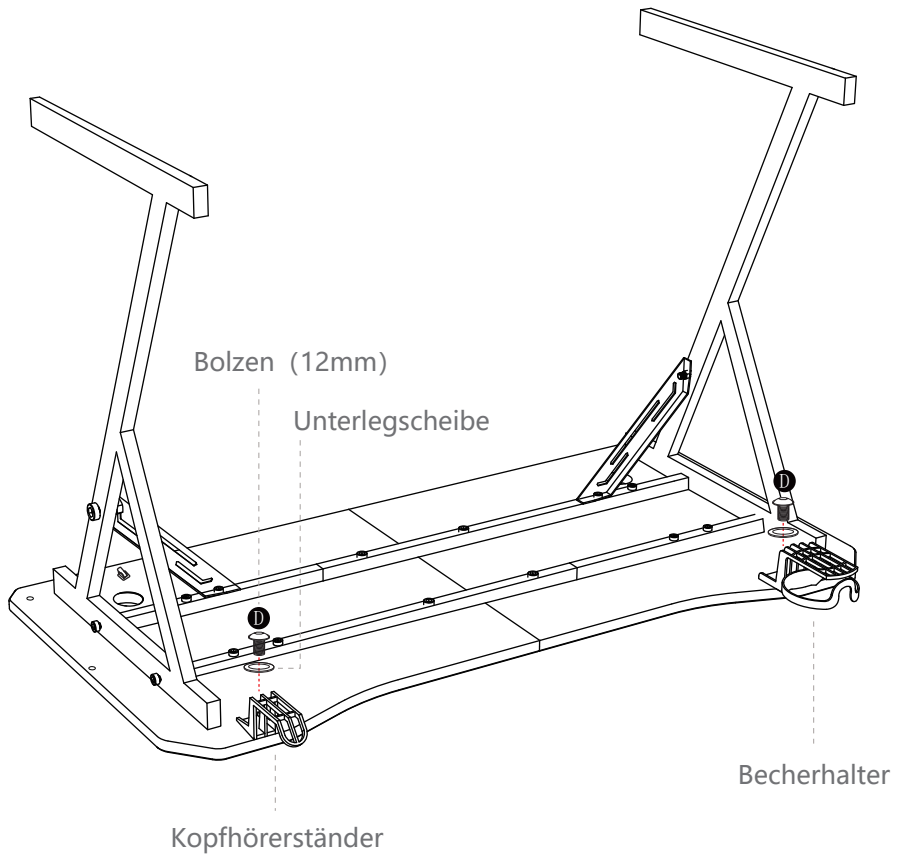

Befestigen Sie den Becherhalter und den Kopfhörerstander.

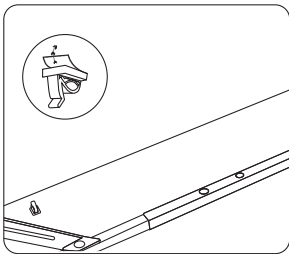
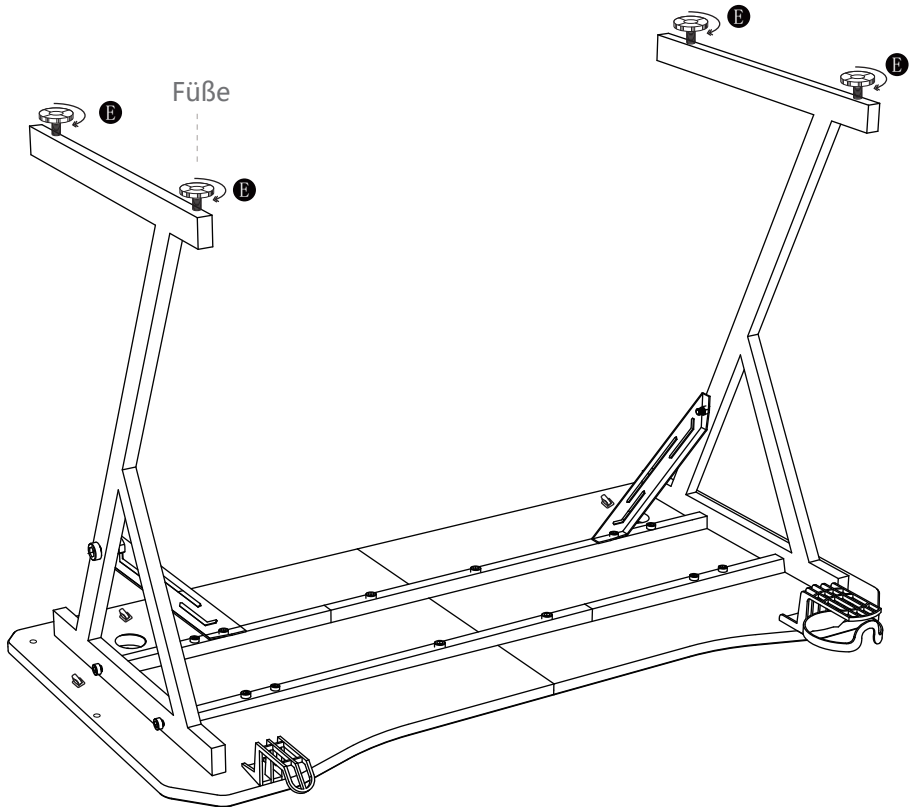
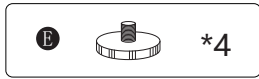

Montieren Sie die FüÙe.

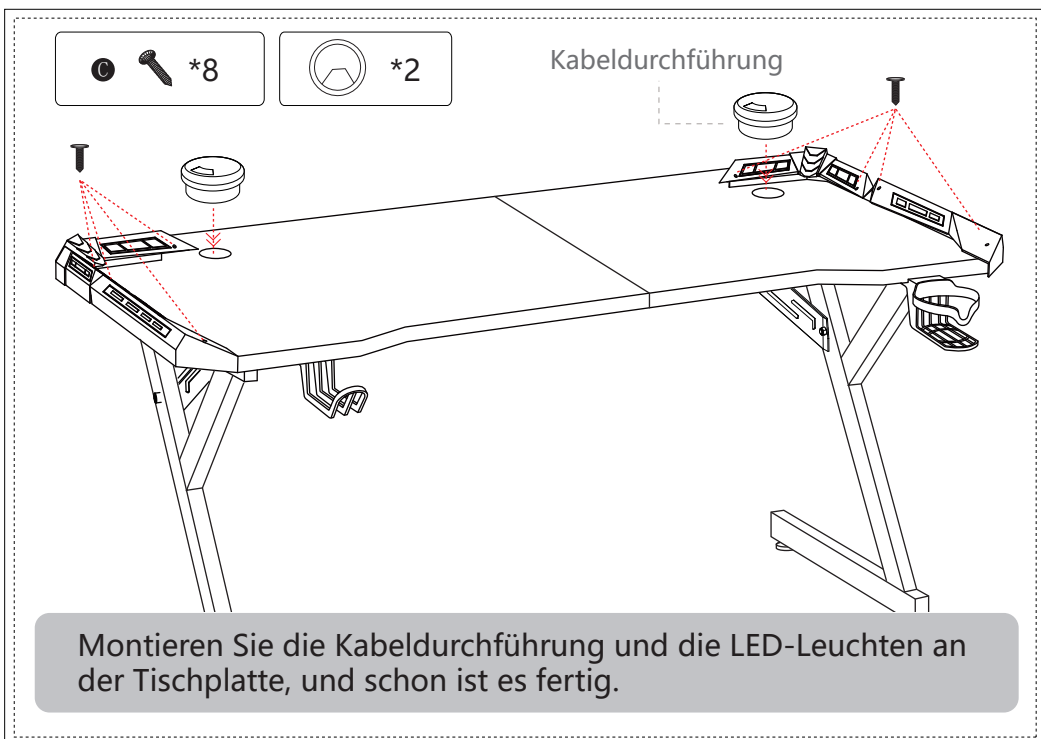
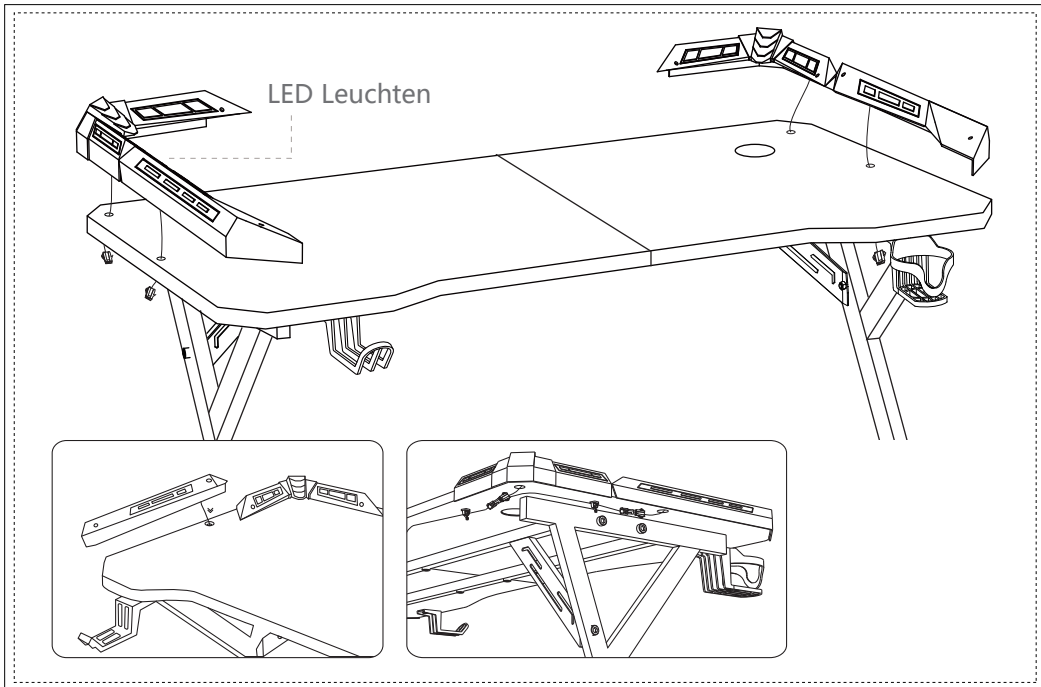

Fissare i due piani  
del tavolo

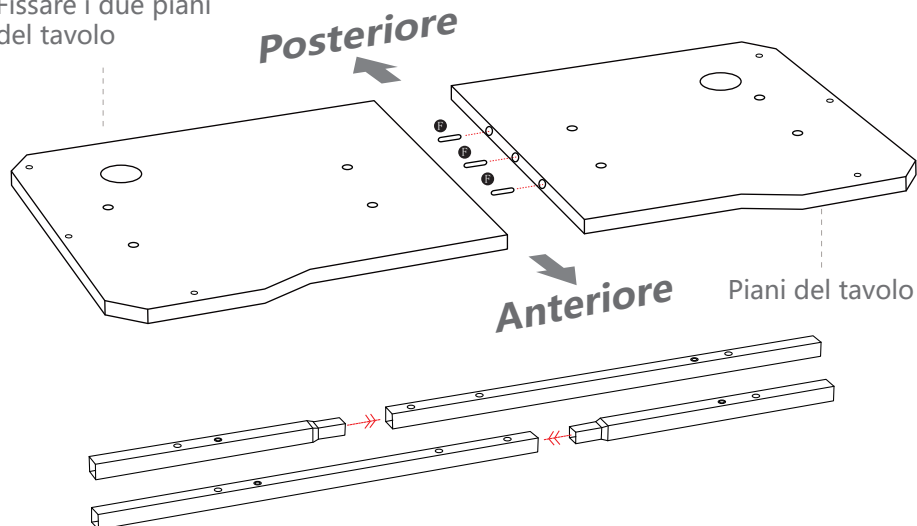

**!** Inserire l'asta di metallo corta nell'asta di metallo lunga.  
Installare come mostrato nel diagramma.

**B**  30mm\*8

 \*8

Bullone (30mm)

Rondella

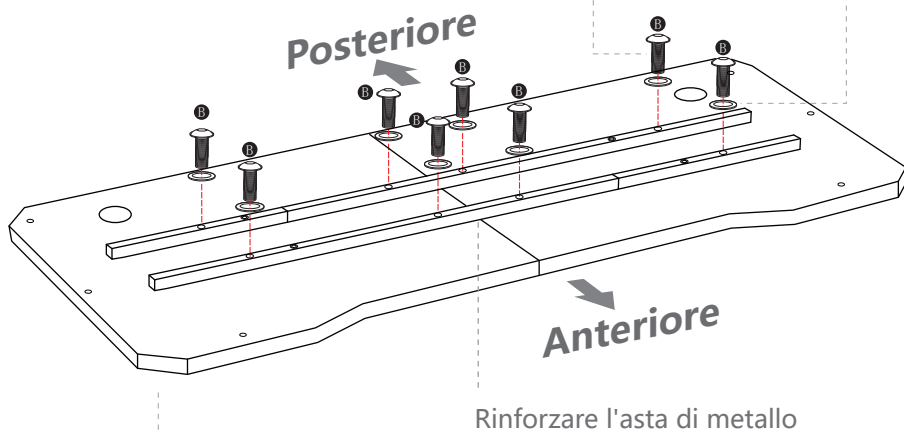

Fissare l'asta di metallo alla  
piani del tavolo.



35mm\*4



\*4

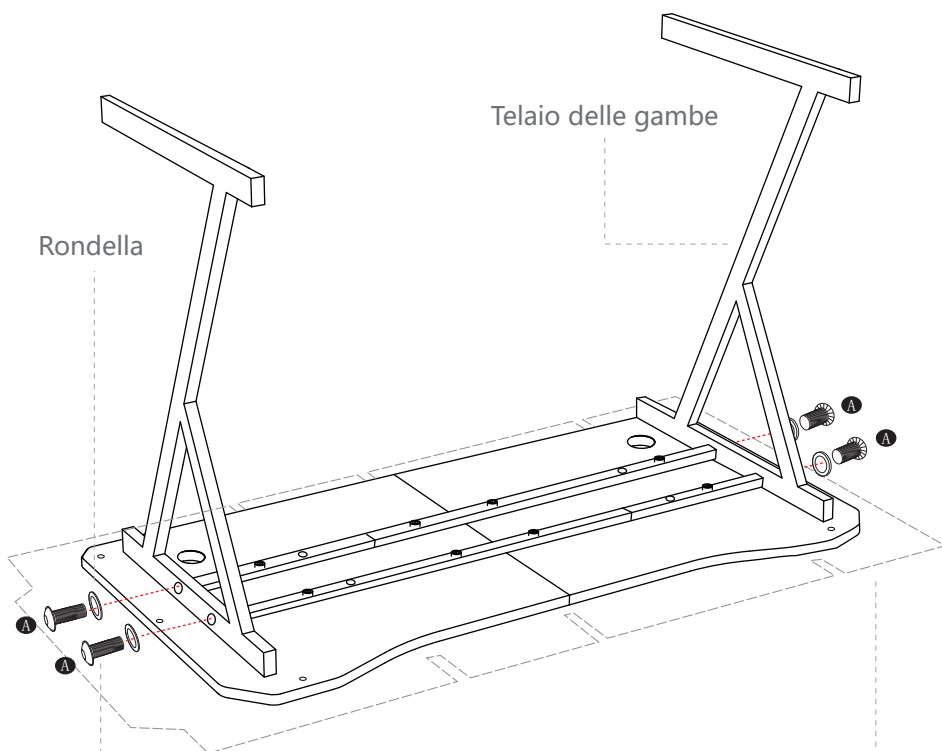

Rondella

Telaio delle gambe

Bullone (35mm)

\* Per favore, lascio un po' allentato durante l'installazione.

Può stendere il cartone dell'imballaggio sul pavimento e usarlo come tappetino per evitare che il piano del tavolo entri in contatto diretto con il pavimento e si danneggi.

**B**  30mm\*2

**D**  12mm\*2

 \*4

 \*2

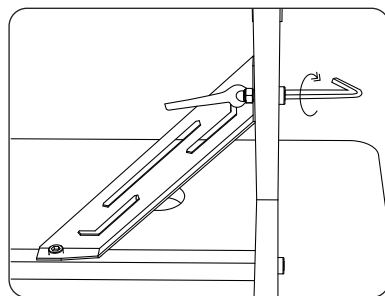
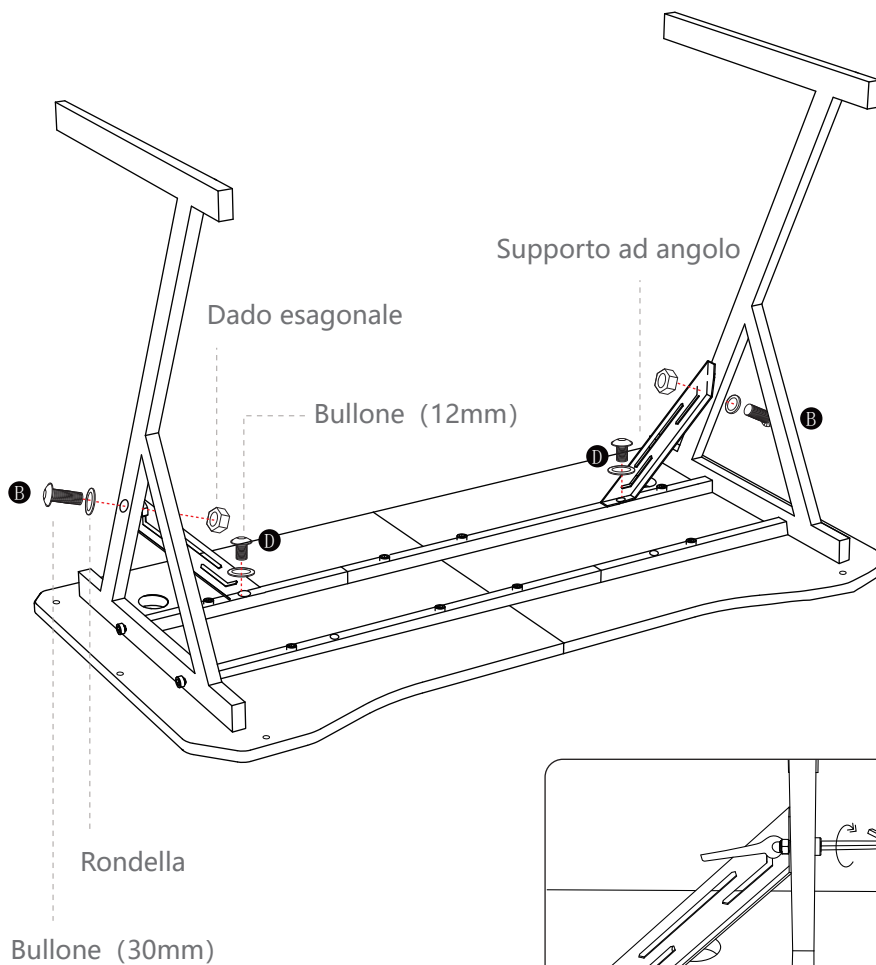

**!** Si prega di non stringere troppo le viti durante il montaggio.  
Prestare particolare attenzione a non stringere completamente tutte le viti finché non sono tutte in posizione.

①  12mm\*2

 \*2

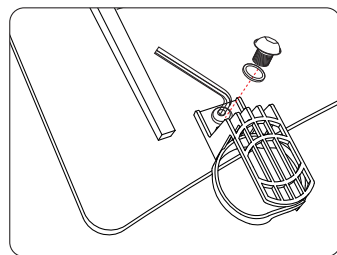
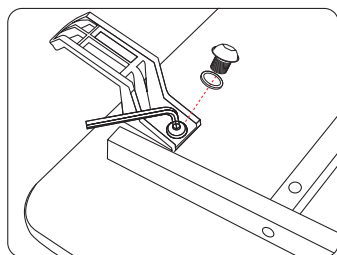
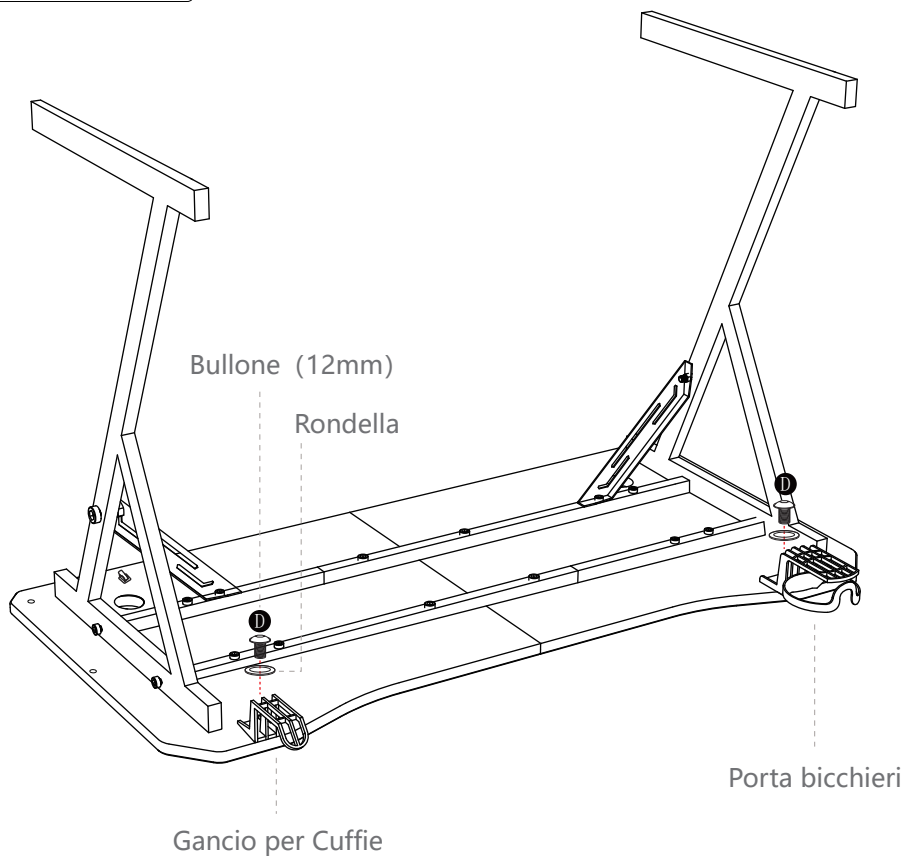

Installare il Porta bicchieri e gancio per cuffie.

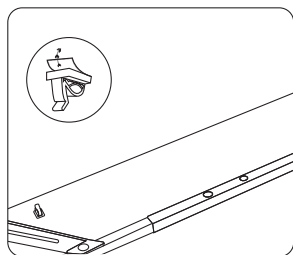
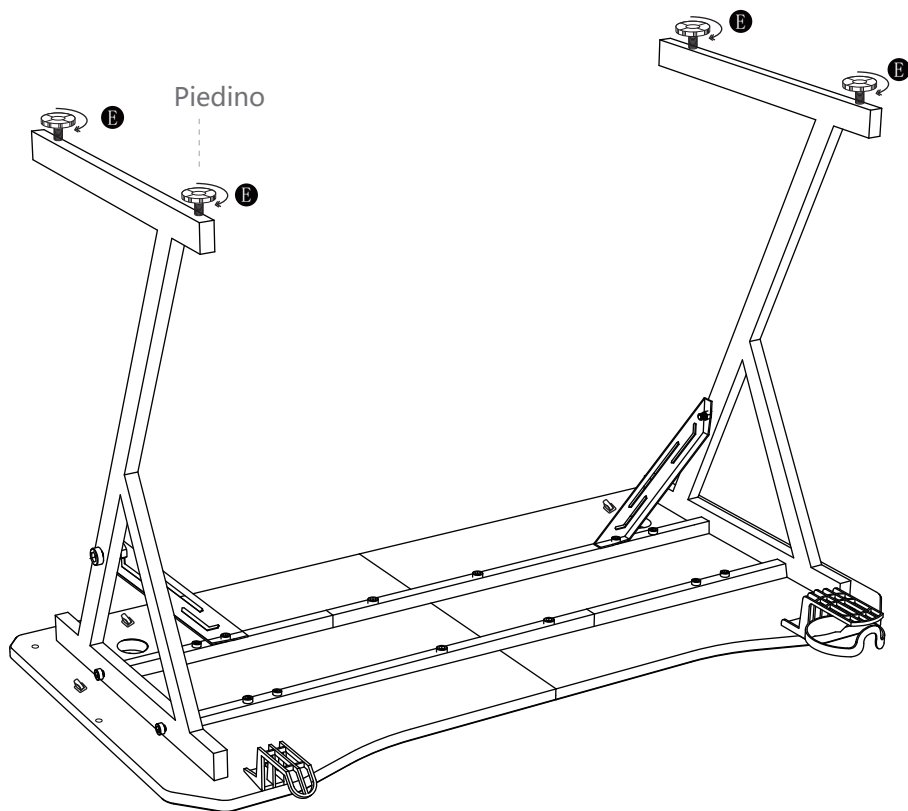
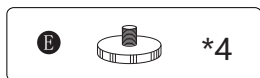

Installare i piedini.

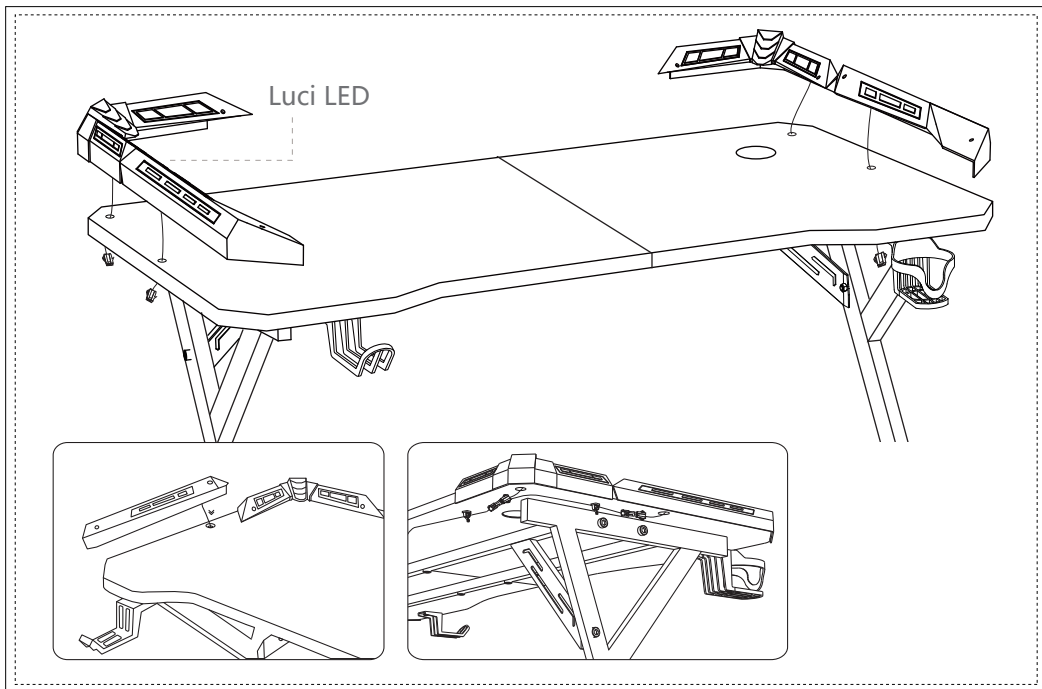

Fixer les deux plateaux  
de la table

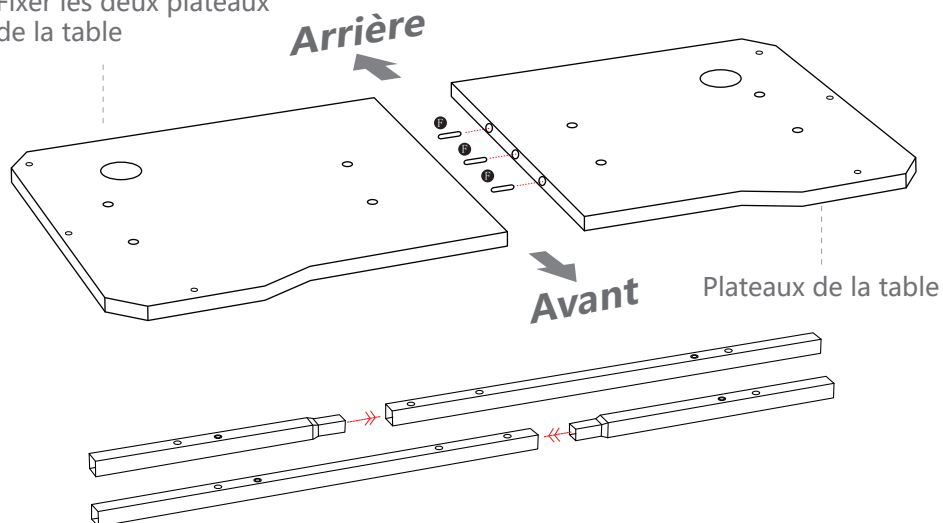

**!** Insérer la tige métallique courte dans la tige métallique longue.  
Installer comme indiqué dans le diagramme.

**B**  30mm\*8

 \*8

Boulon (30mm)

Rondelle

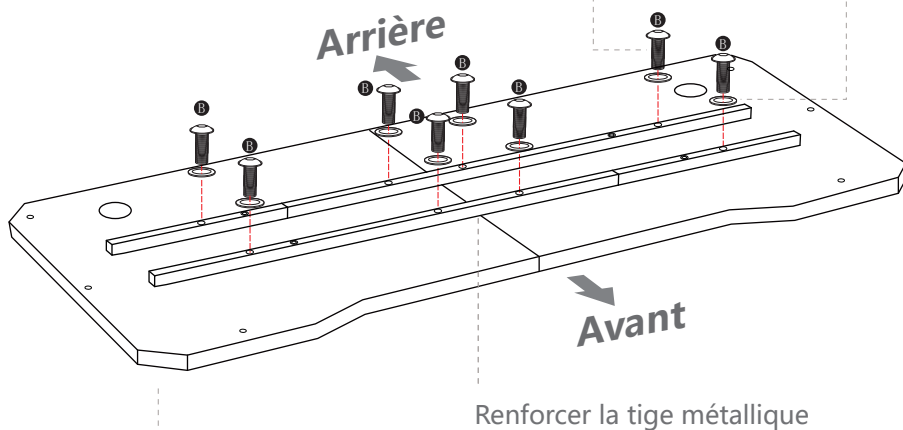

Fixer la tige métallique aux  
plateaux de la table.

  35mm\*4

 \*4

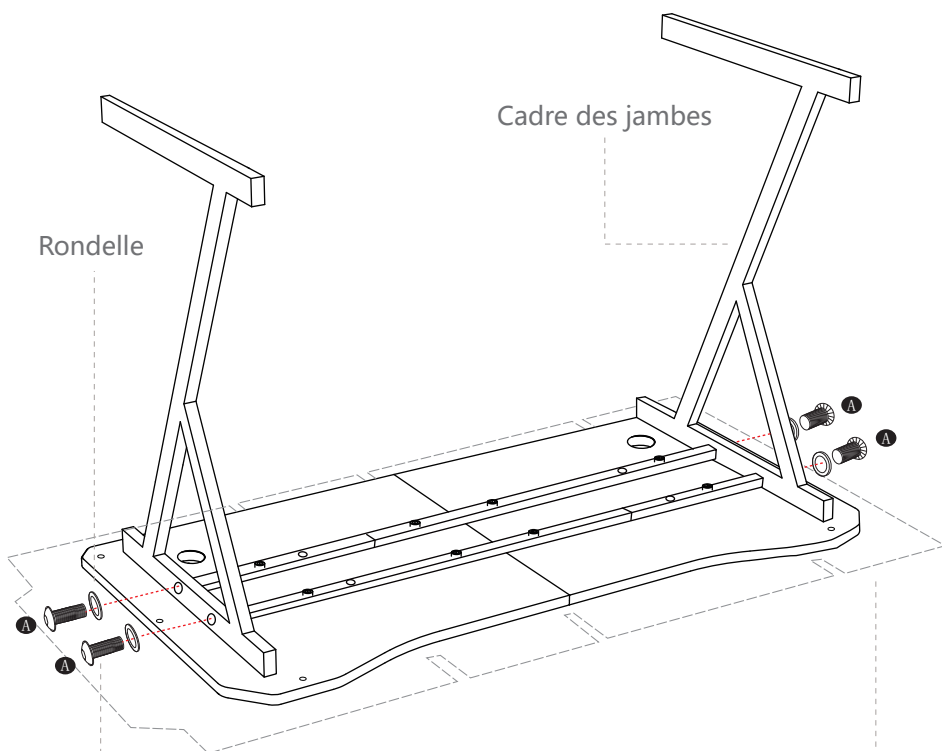

Rondelle

Cadre des jambes

Boulon (35mm)

※ Veuillez le laisser un peu lâche lors de l'installation.

Vous pouvez étaler le carton d'emballage sur le sol et l'utiliser comme tapis pour éviter que le plateau de la table n'entre en contact direct avec le sol et ne s'abîme.

**B**  30mm\*2

**D**  12mm\*2

 \*4

 \*2

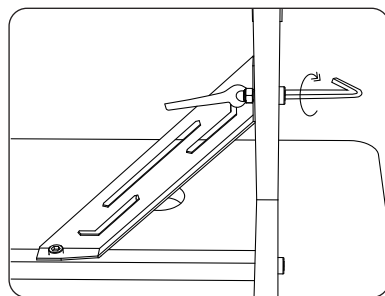
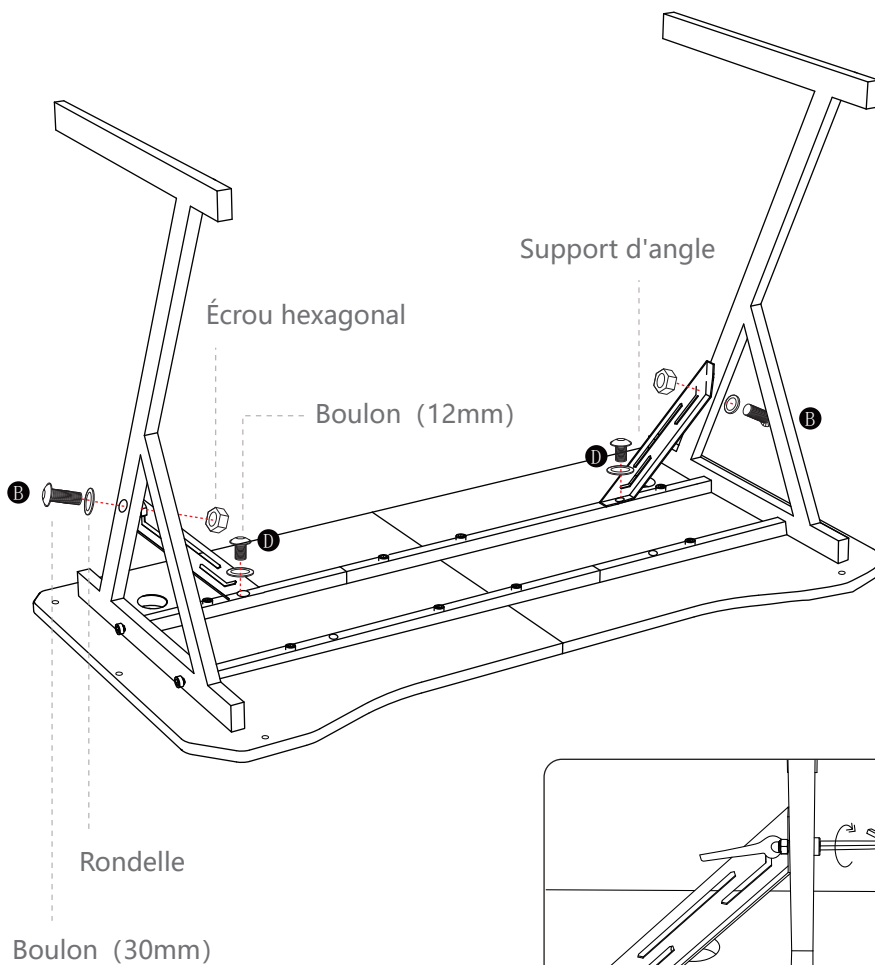

**⚠** Veuillez ne pas serrer trop les vis pendant l'assemblage.  
Faites particulièrement attention à ne pas serrer complètement toutes les vis tant qu'elles ne sont pas toutes en place.

①  12mm\*2

 \*2

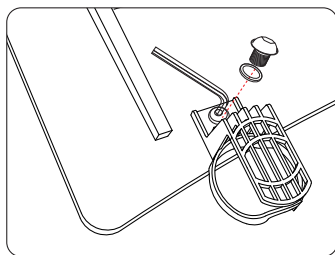
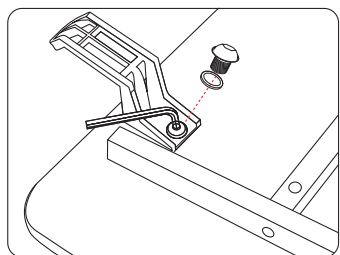
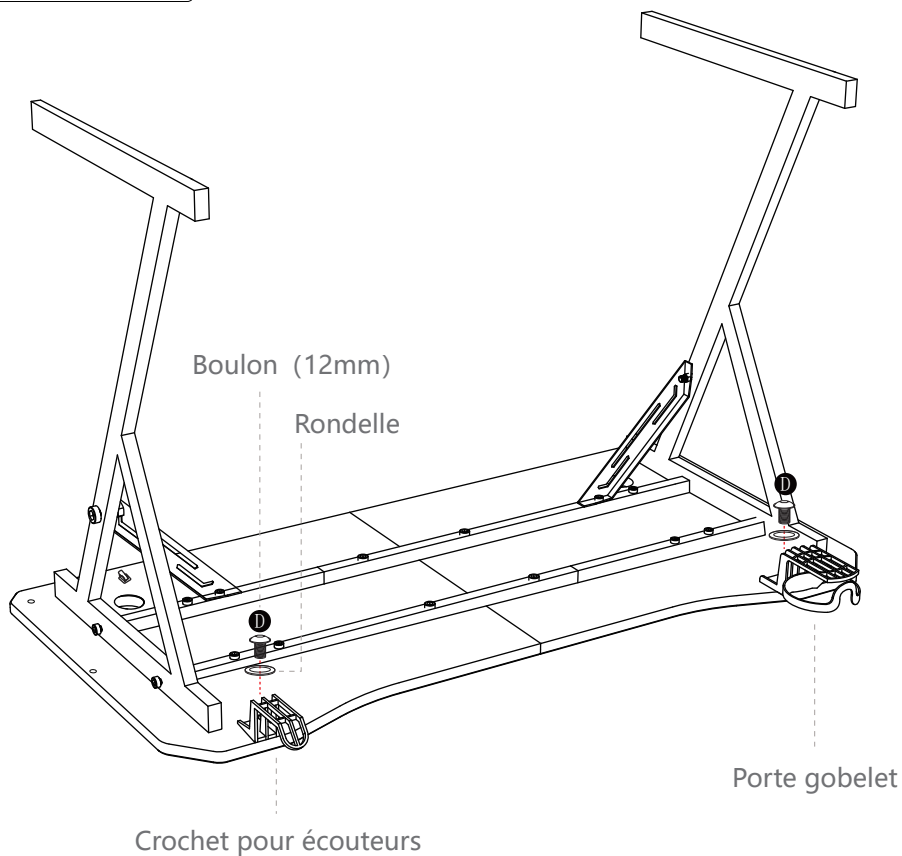

Installer le porte-gobelet et le crochet pour écouteurs.

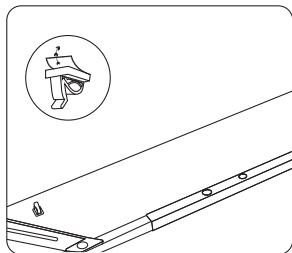
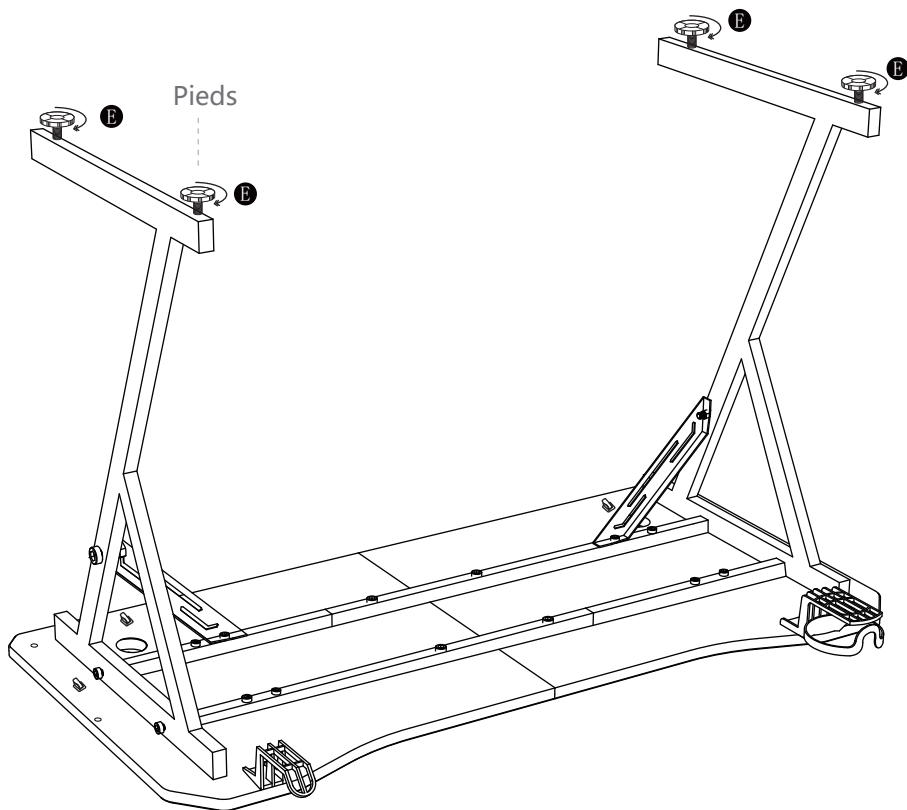
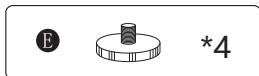

Installer les pieds.

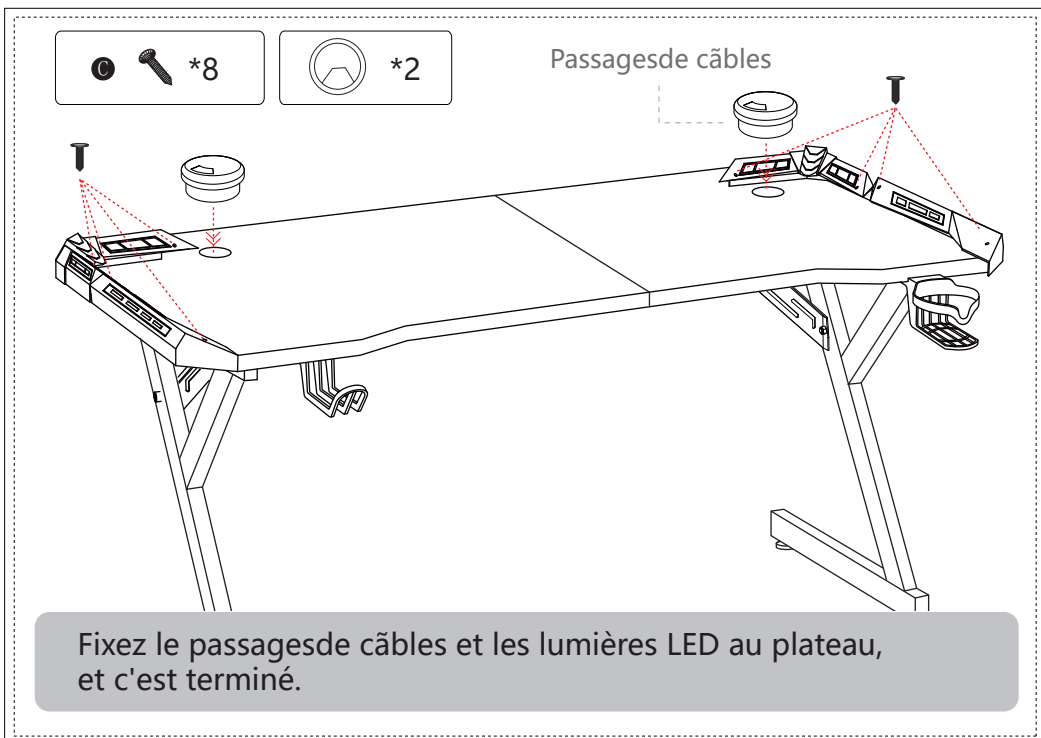
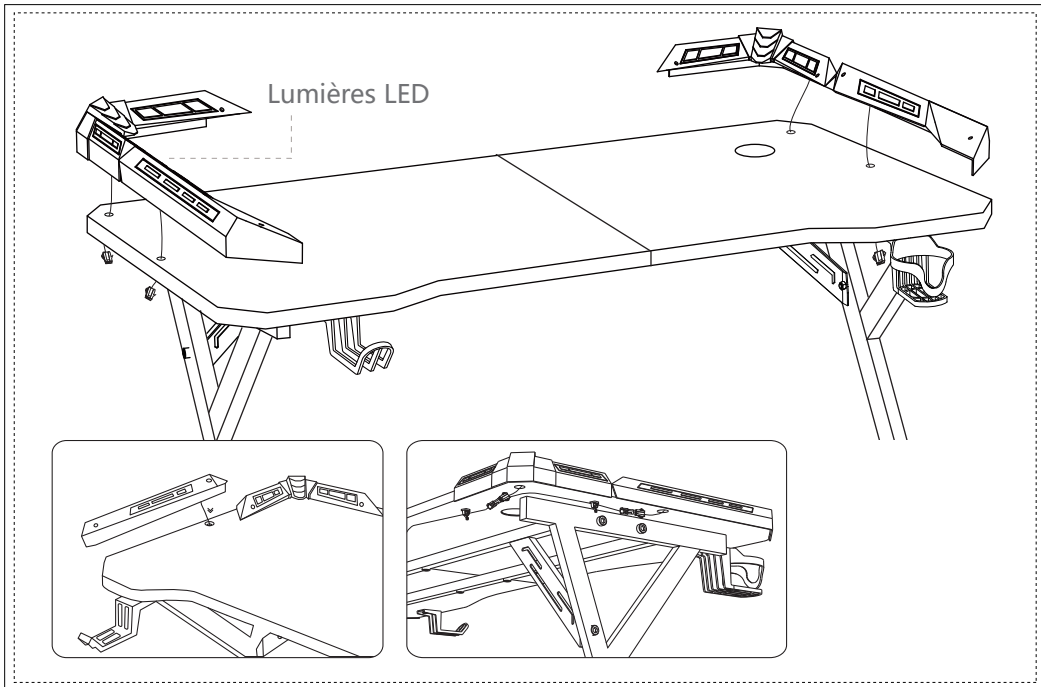

Fijar las dos partes  
del tablero

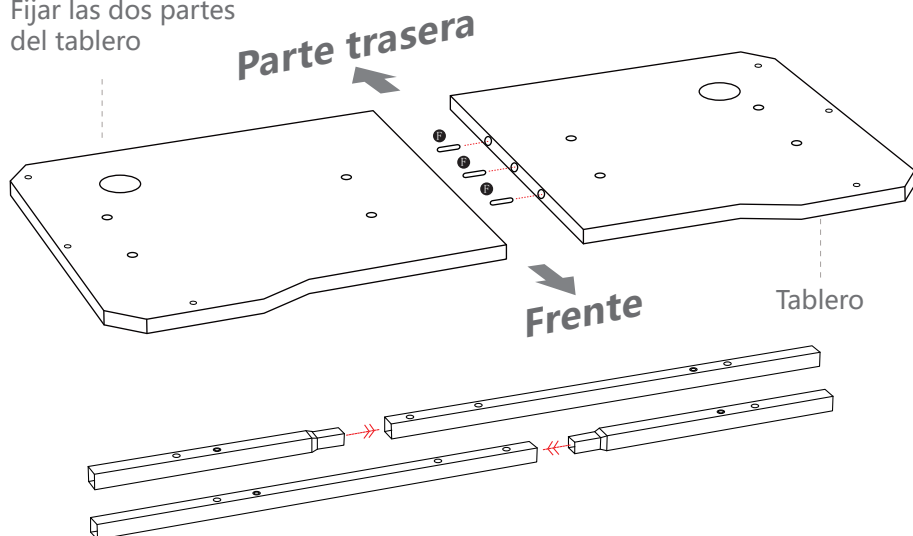

**!** Inserte la varilla más corta en la varilla más larga y móntelo como se muestra en la imagen.

**B**  30mm\*8

 \*8

Tornillo (30mm) Arandela

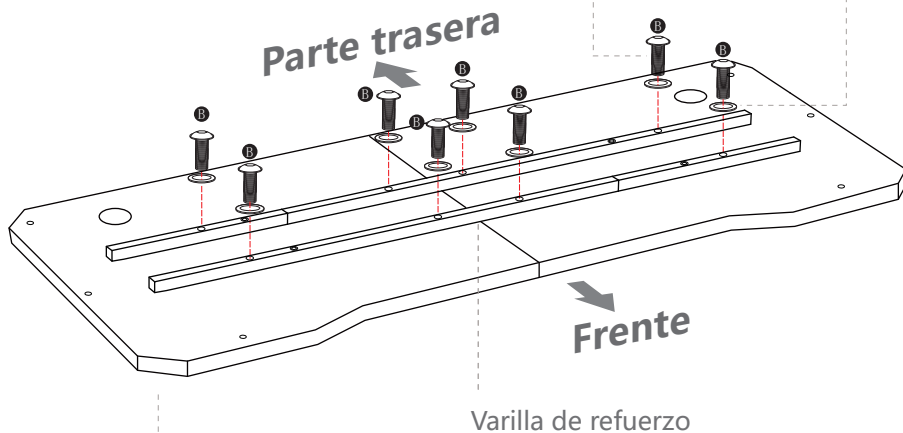

Fije el marco a la tabla  
utilizando los tornillos



35mm\*4



\*4

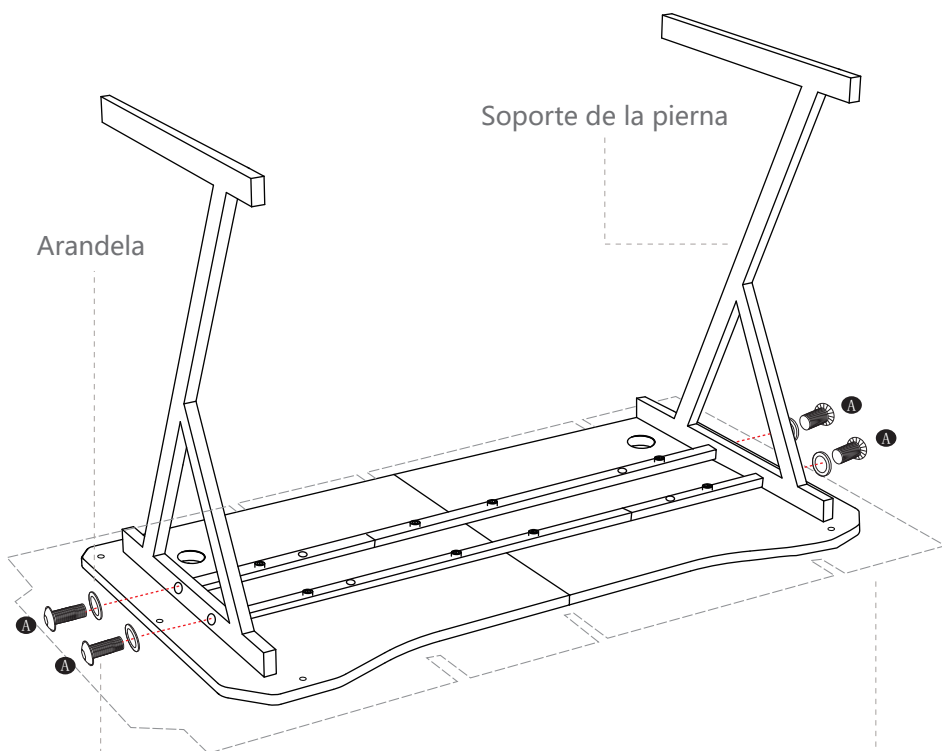

Arandela

Soporte de la pierna

Tornillo (35mm)

\* Por favor, instale en un estado suelto.

Puede extender la caja de embalaje en el suelo y usarla como acolchado para evitar que la superficie de la mesa entre en contacto directo con el suelo y se dañe.

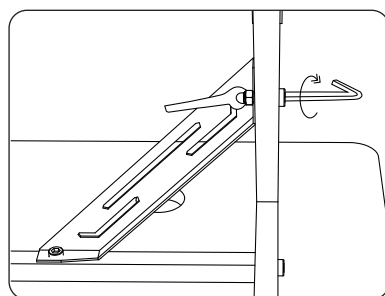
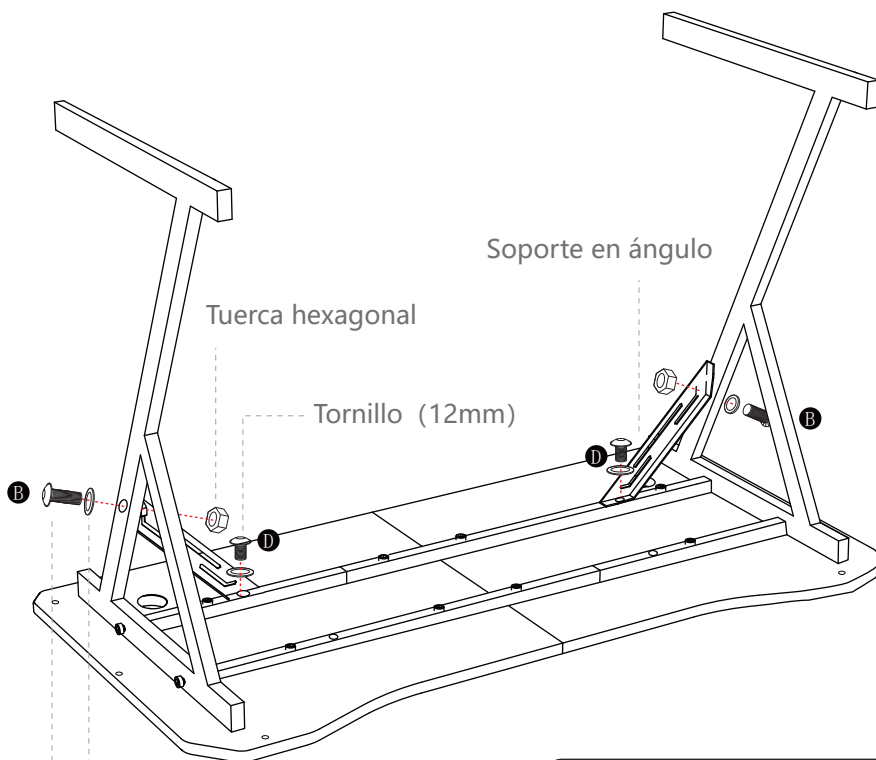

**!** Por favor, tenga en cuenta que debe apretar cada tornillo solo después de haber fijado todos los tornillos.

①  12mm\*2

 \*2

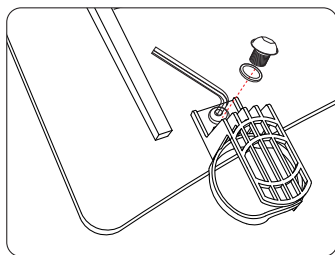
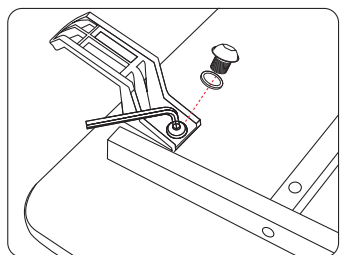
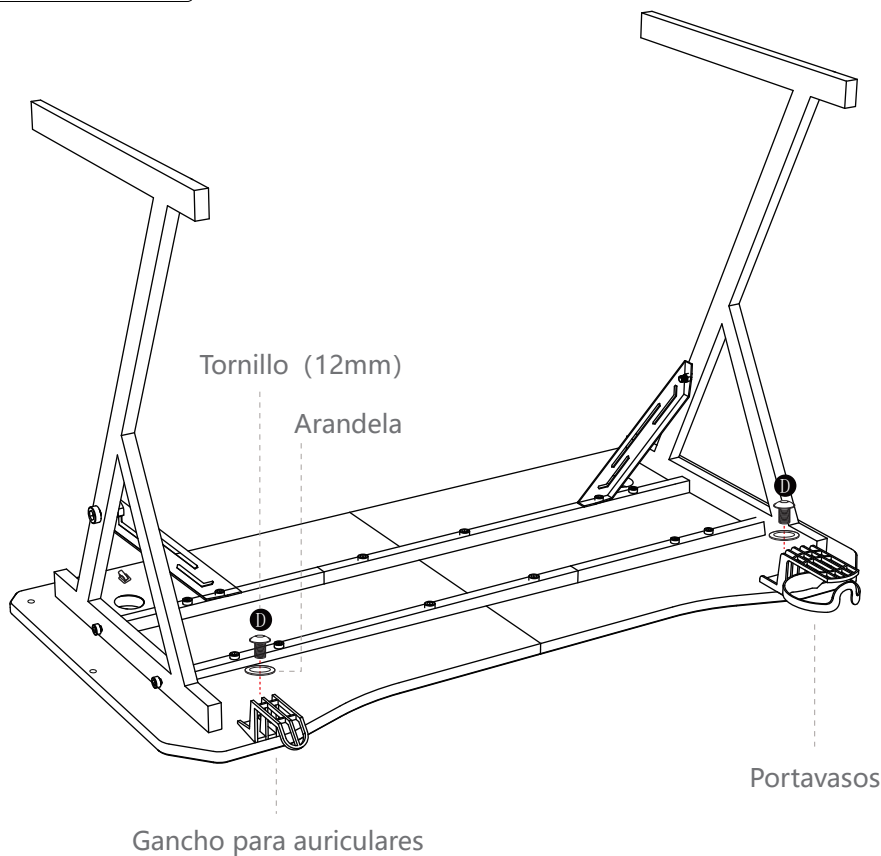

Instale el portavasos y el gancho para auriculares.



**E** \*4

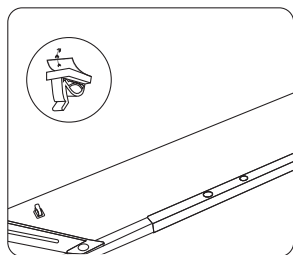
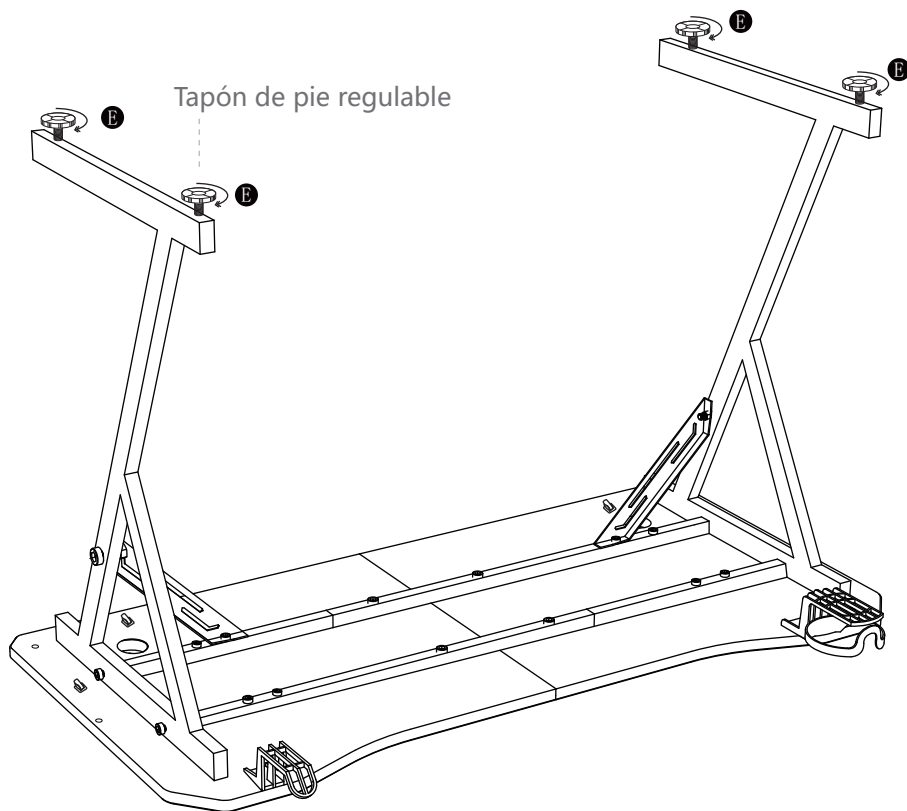

Instale el tapón de pie regulable.

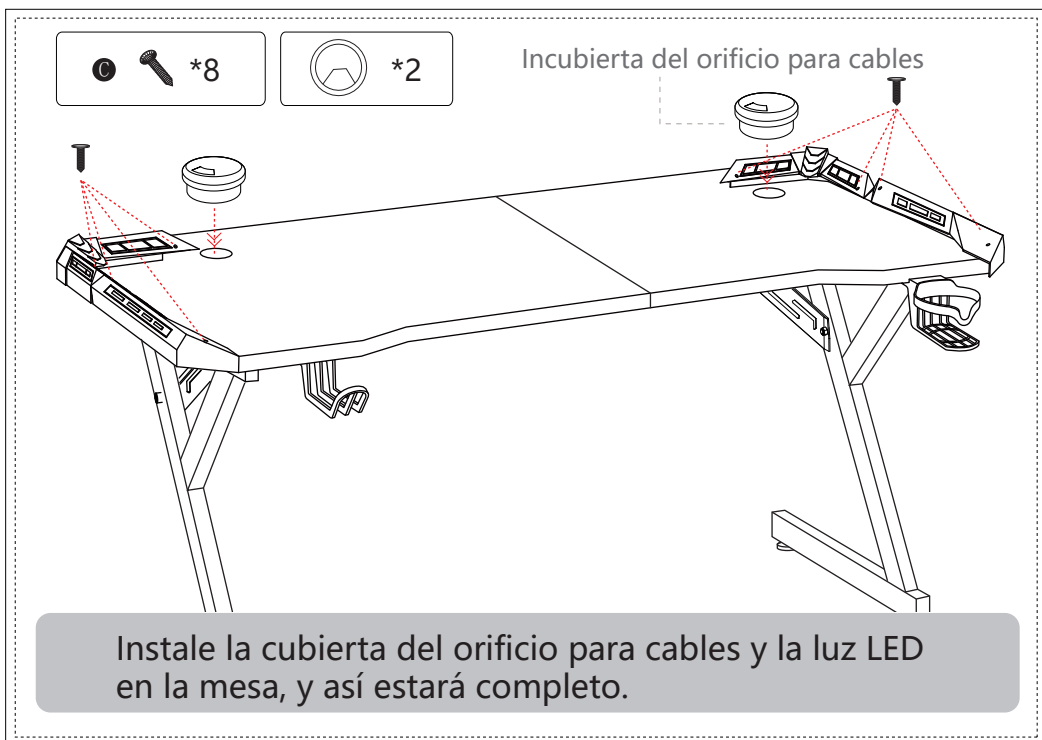
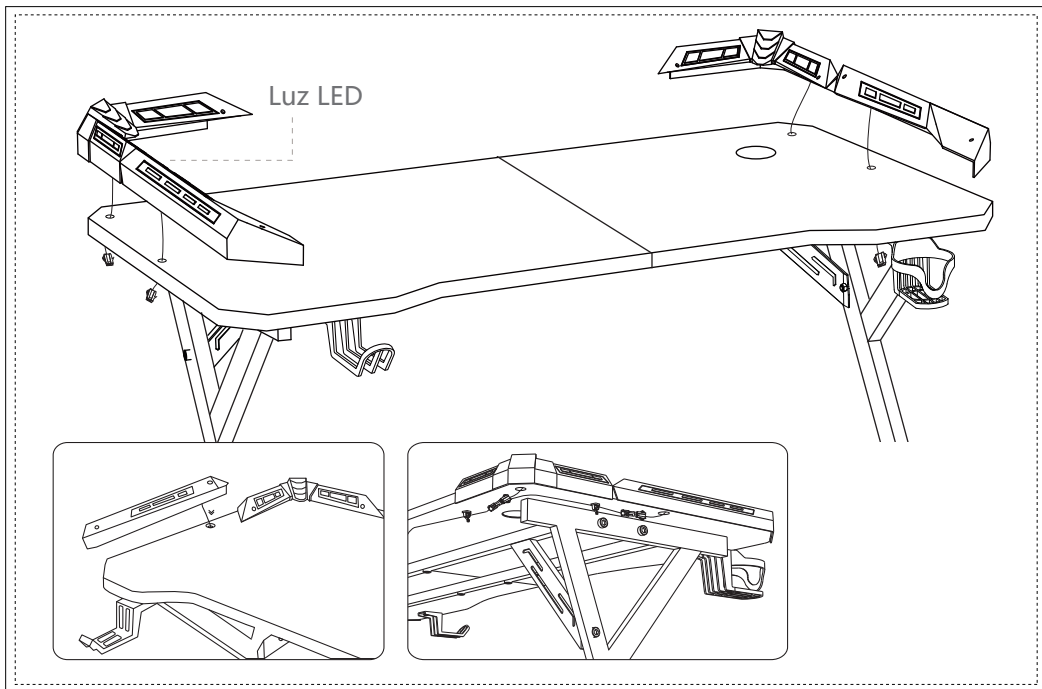

Fäst de två  
bordsskivorna

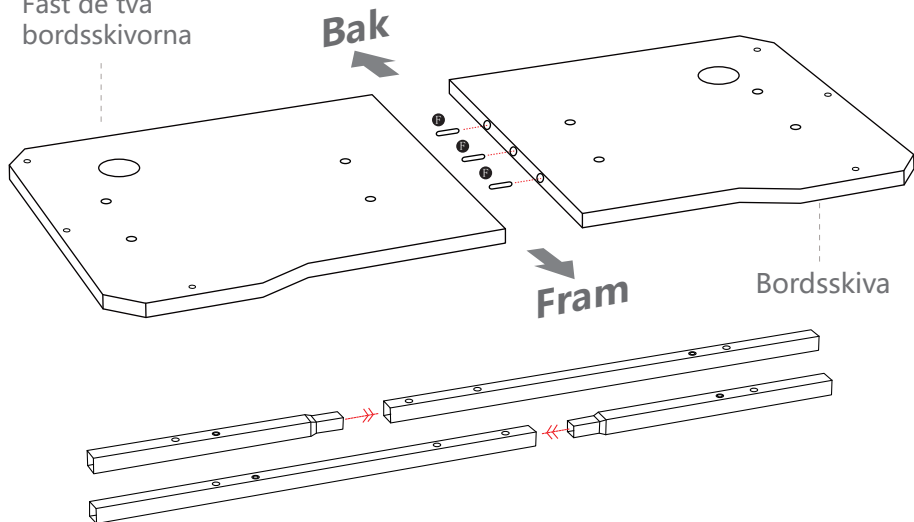

**!** Sätt in den korta metallstangen i den långa metallstangen som visas på bilden.

**B**  30mm\*8

 \*8

Bultar (30mm)

Skivor

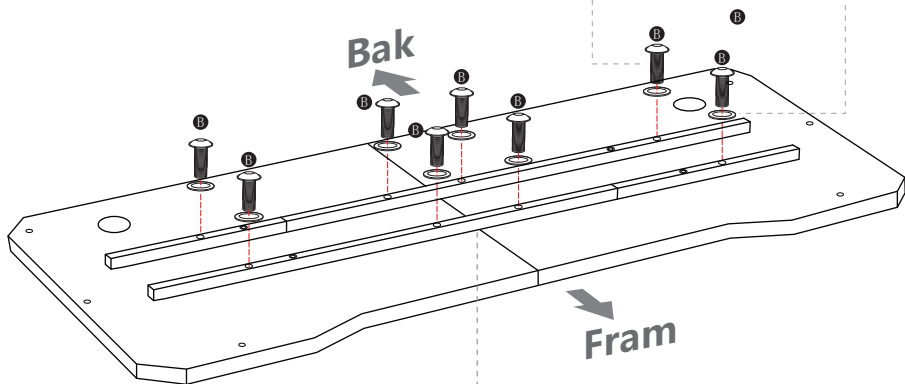

Fäst ramen på bordsskivan



35mm\*4



\*4

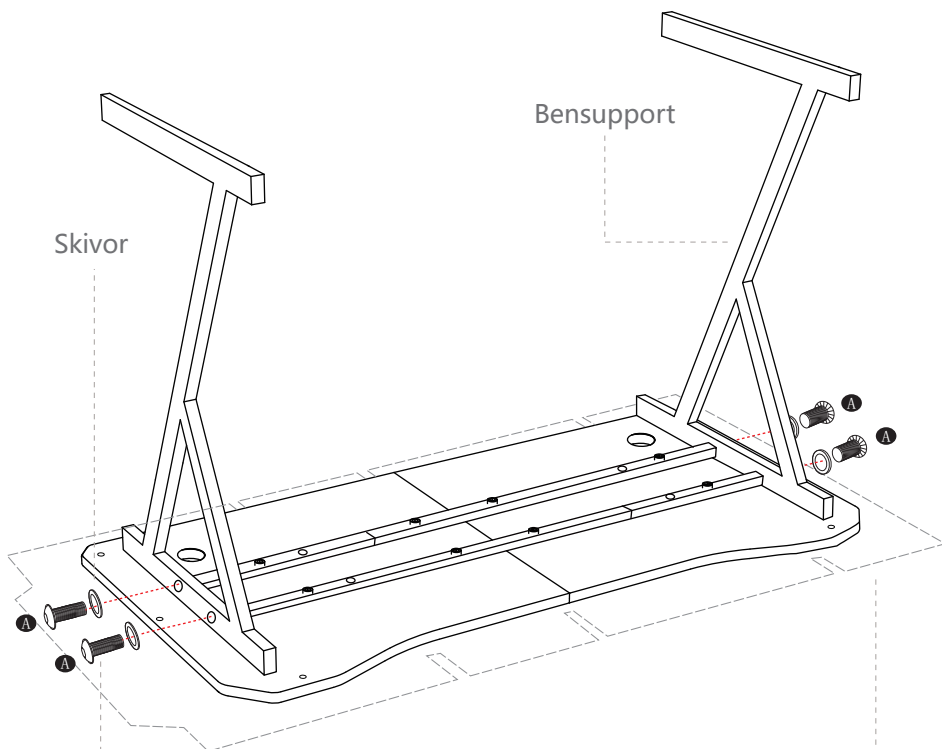

Bultar (35mm)

※ Var god installera i ett löst tillstånd.

Du kan lägga ut förpackningslådan på golvet och använda den som underlag för att förhindra att bordsskivan kommer i direkt kontakt med golvet och blir skadad.

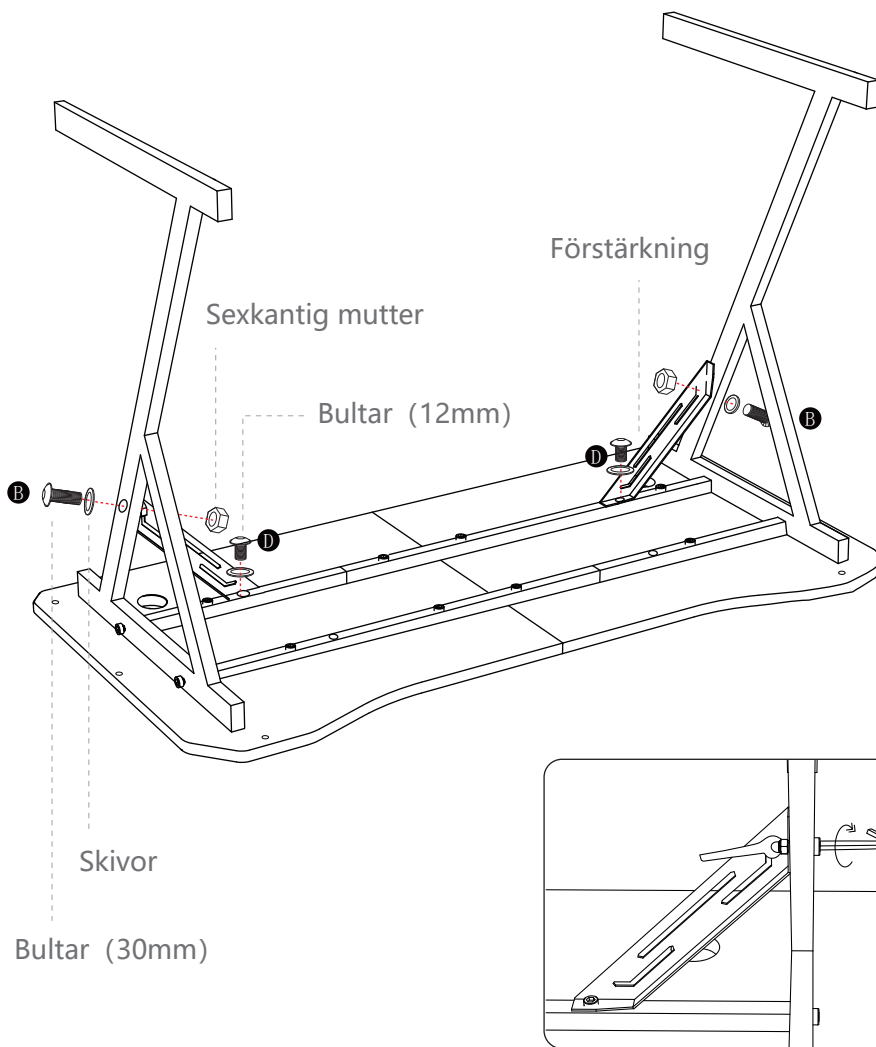
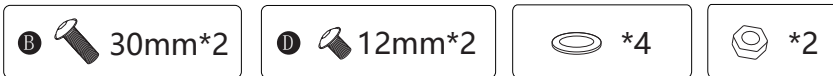

- ⚠** Var noga med att inte dra åt skruvarna för hårt under monteringen. När alla skruvar är på plats, dra åt dem alla samtidigt.

①  12mm\*2

 \*2

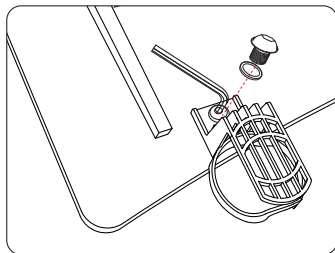
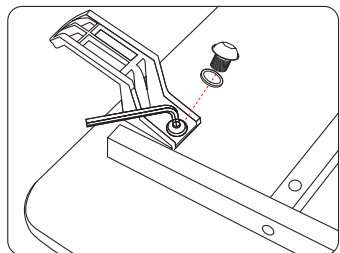
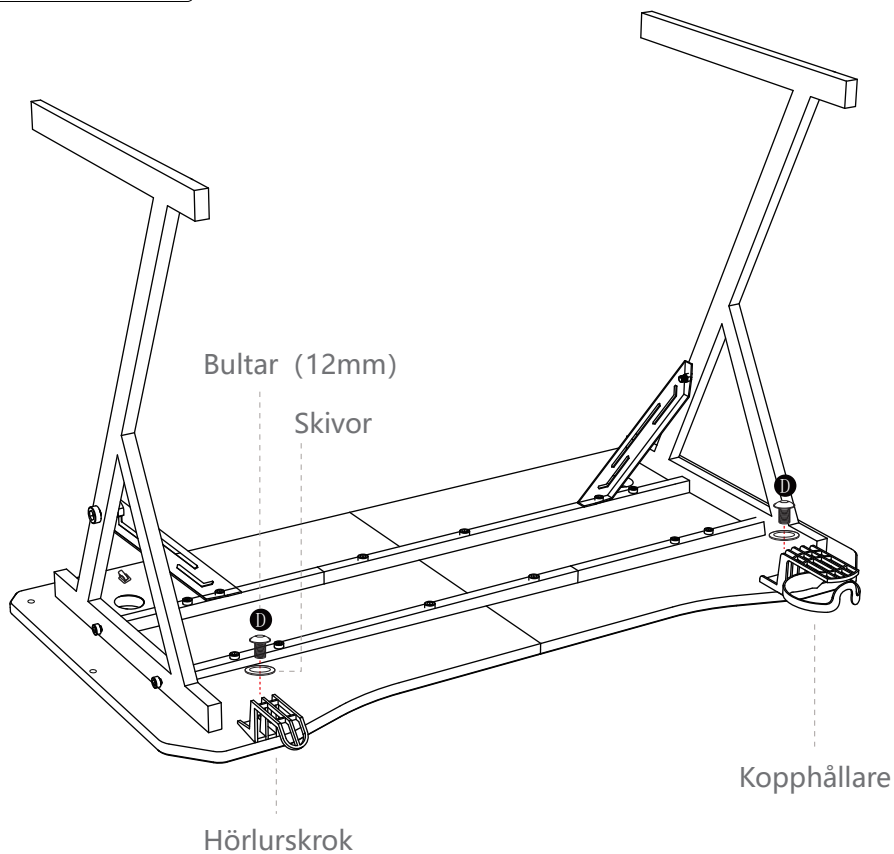

Installera kopphållare och hörlurskrok.

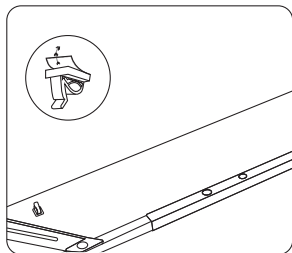
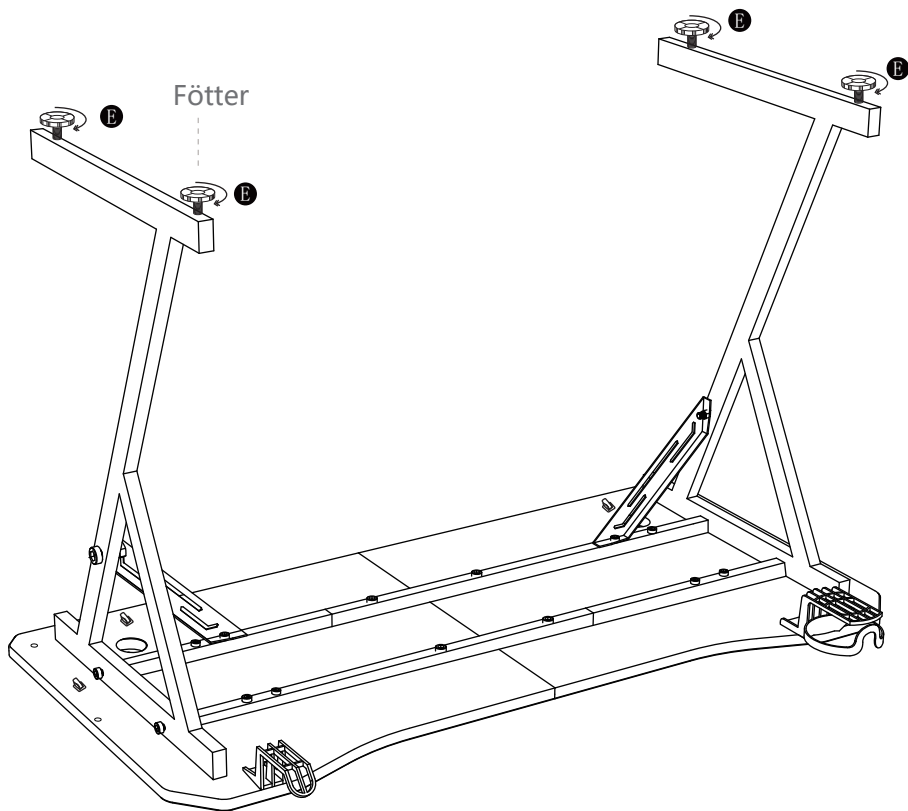
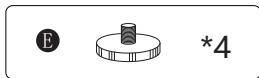

Installera fötter

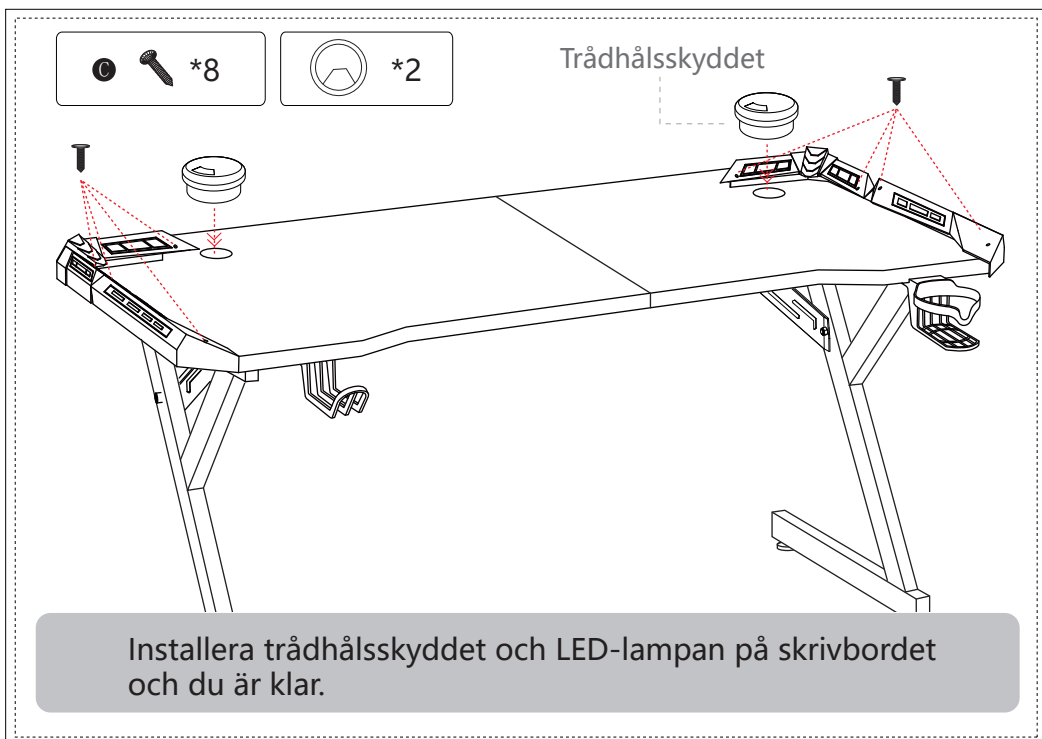
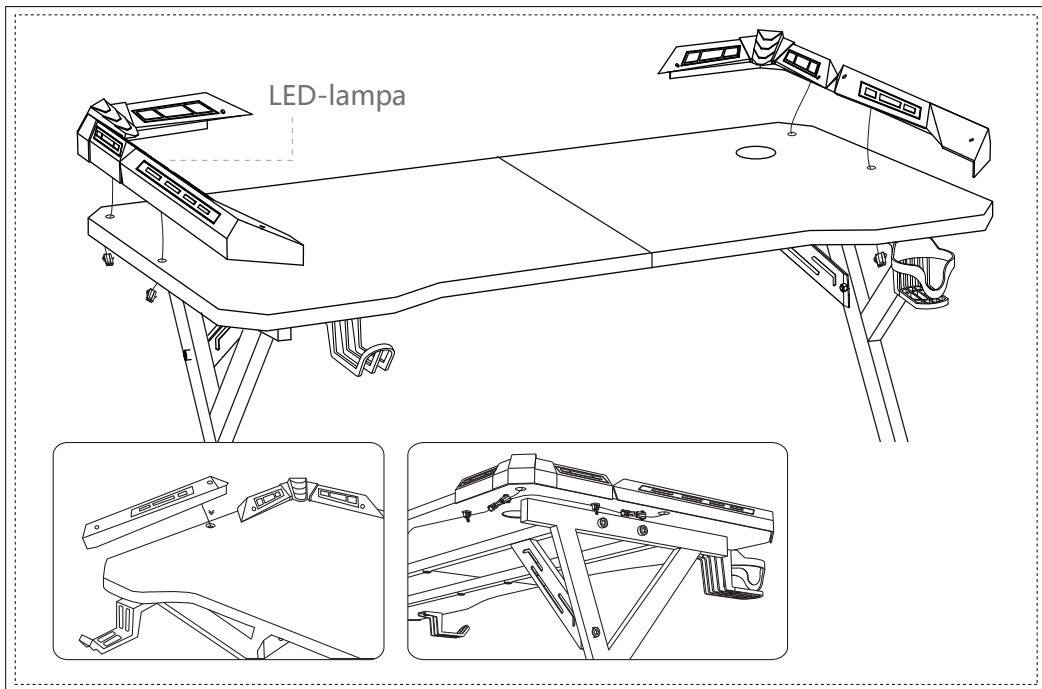

Bevestig de twee  
tafelbladen

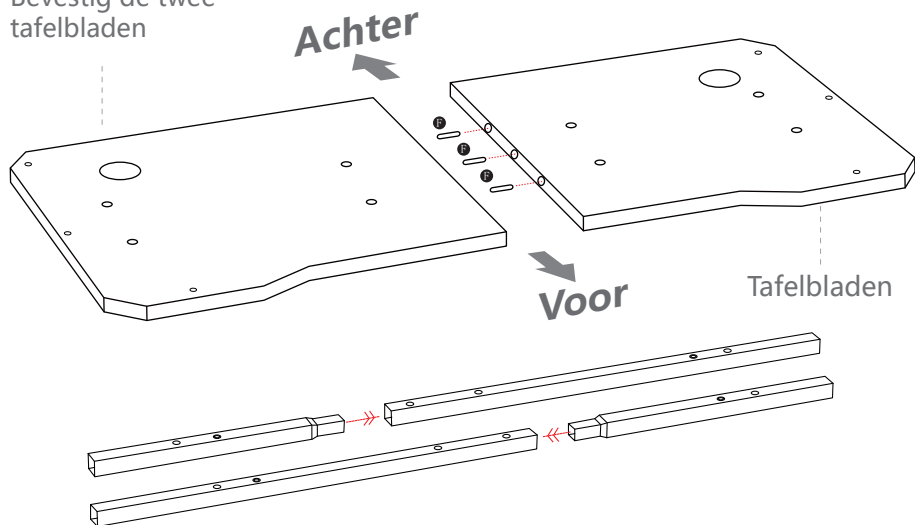

**!** Steek de korte metalen staaf in de lange metalen staaf zoals weergegeven in de afbeelding.

**B**  30mm\*8

 \*8

Bouten (30mm)

Ringetjes

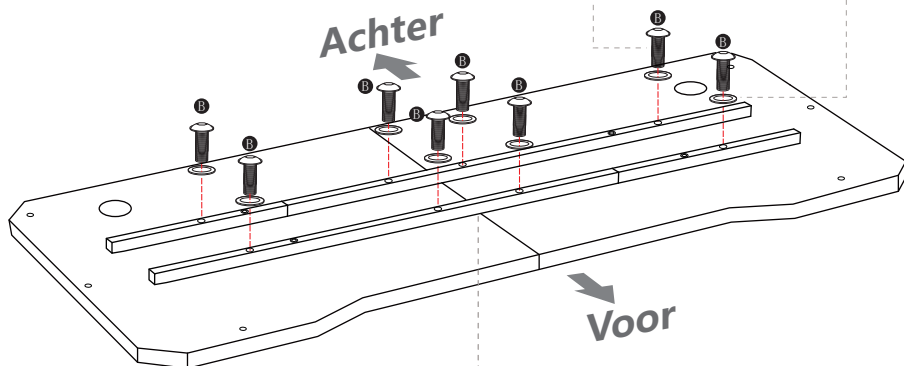

Bevestig het frame aan  
het tafelblad



35mm\*4



\*4

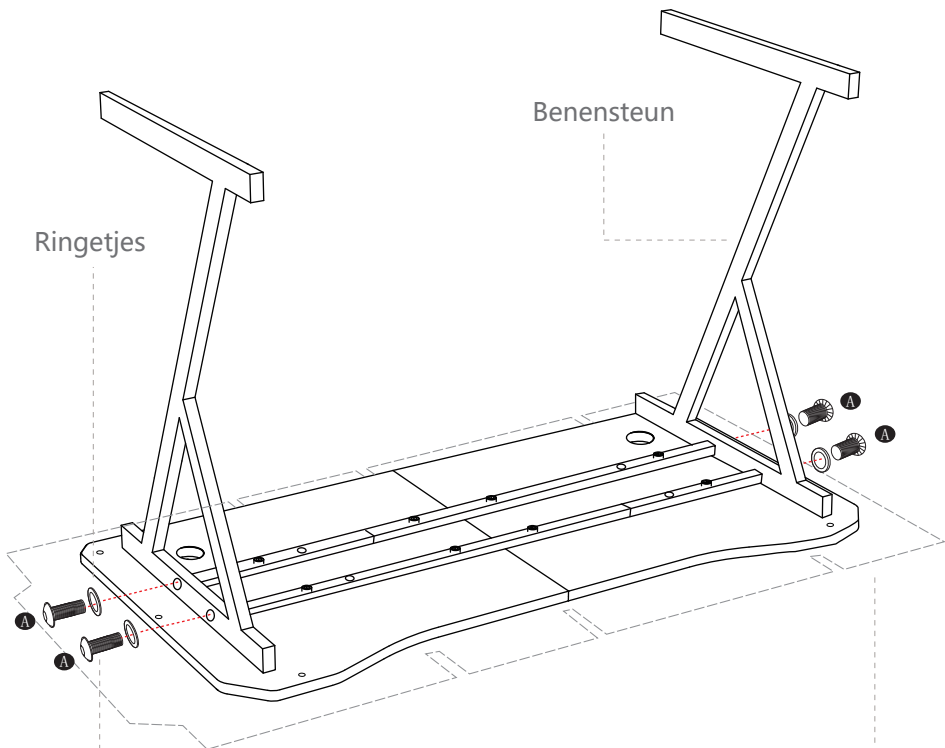

Bouten (35mm)

※ Installeer alstublieft in een losse staat.

U kunt de verpakingsdoos plat op de vloer leggen en als onderlegger gebruiken om te voorkomen dat het tafelblad direct in contact komt met de vloer en beschadigd raakt.

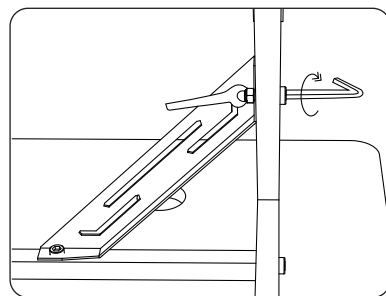
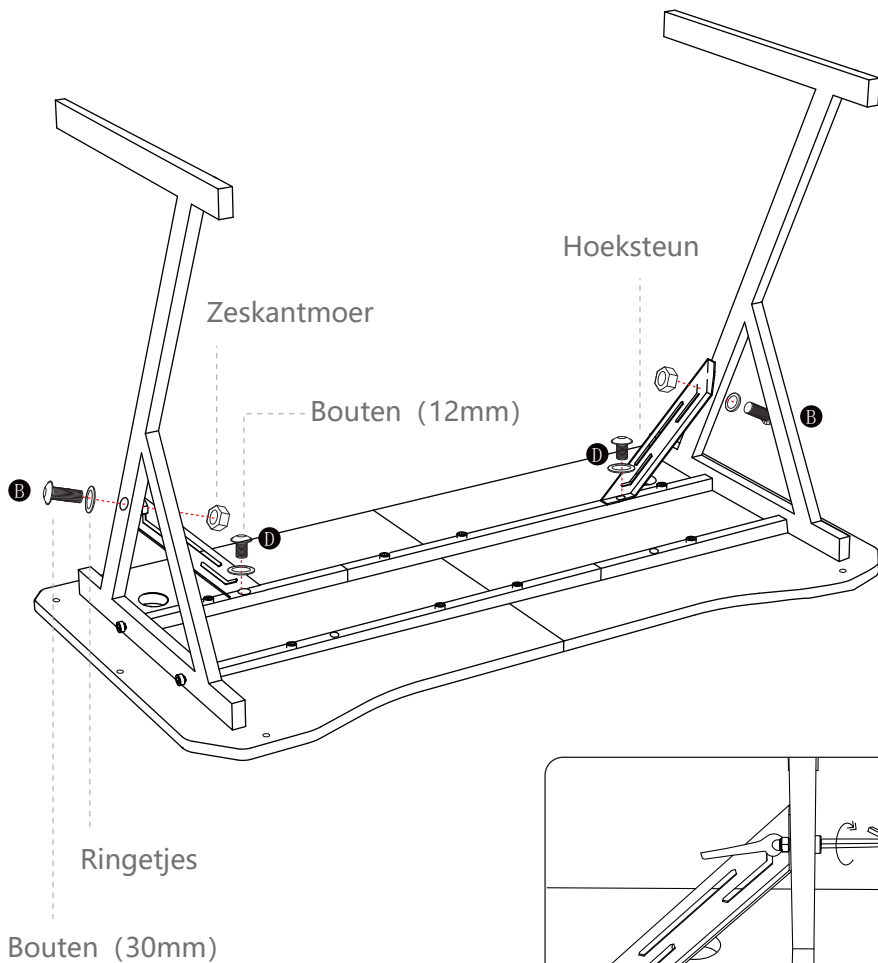
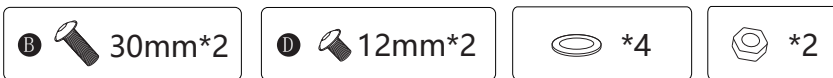

- !** Wees er alstublieft voorzichtig mee om de schroeven tijdens het monteren niet te strak aan te draaien. Wanneer alle schroeven op hun plaats zitten, draai ze dan allemaal tegelijk aan.

①  12mm\*2

 \*2

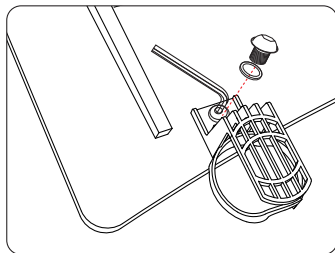
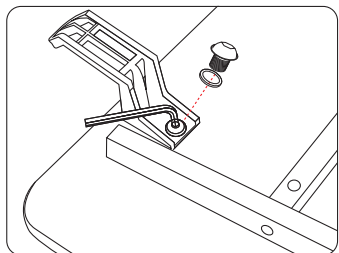
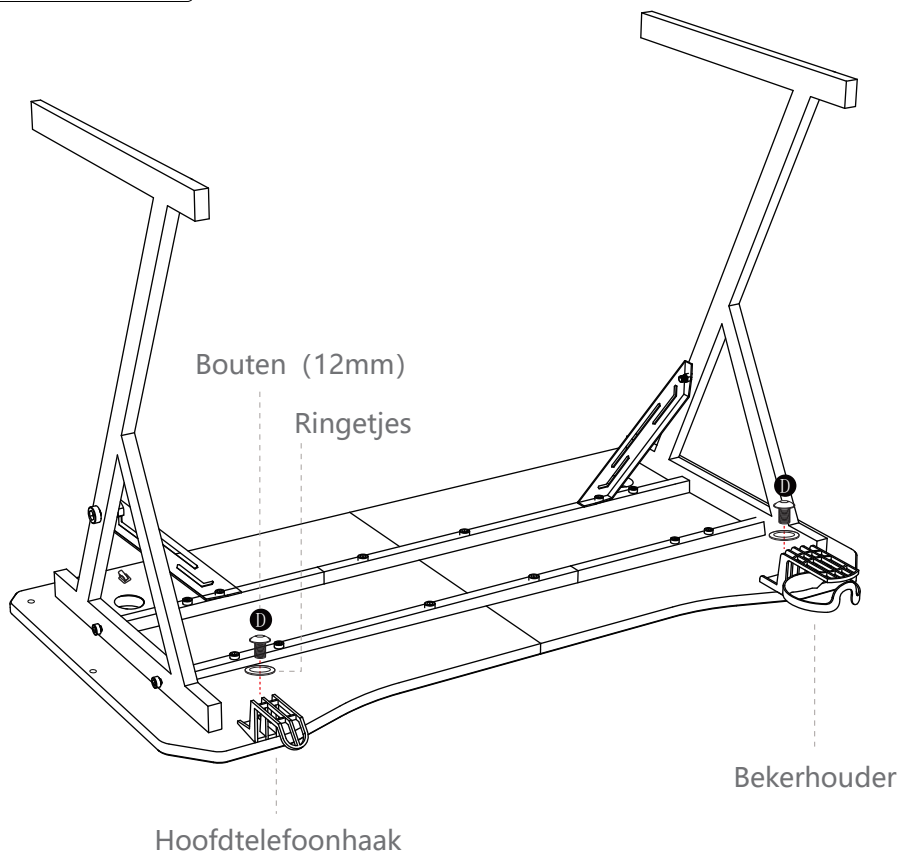

Installeer bekerhouder en hoofdtelefoonhaak.

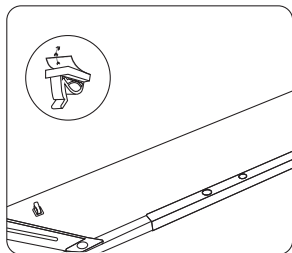
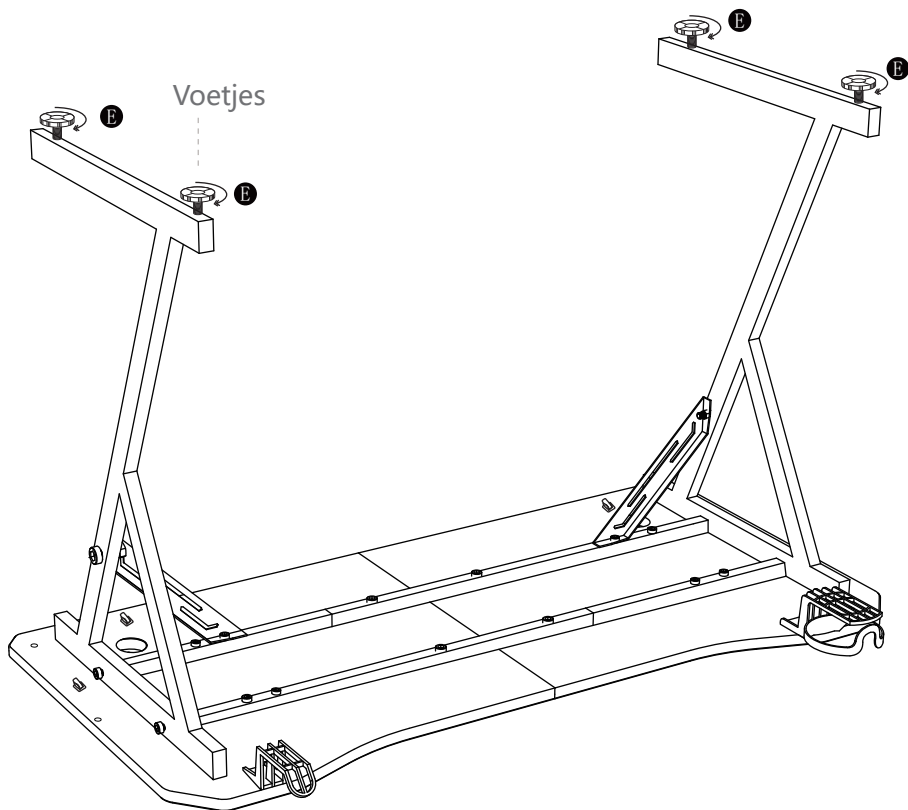
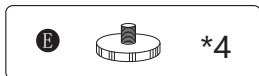

Voetjes installeren

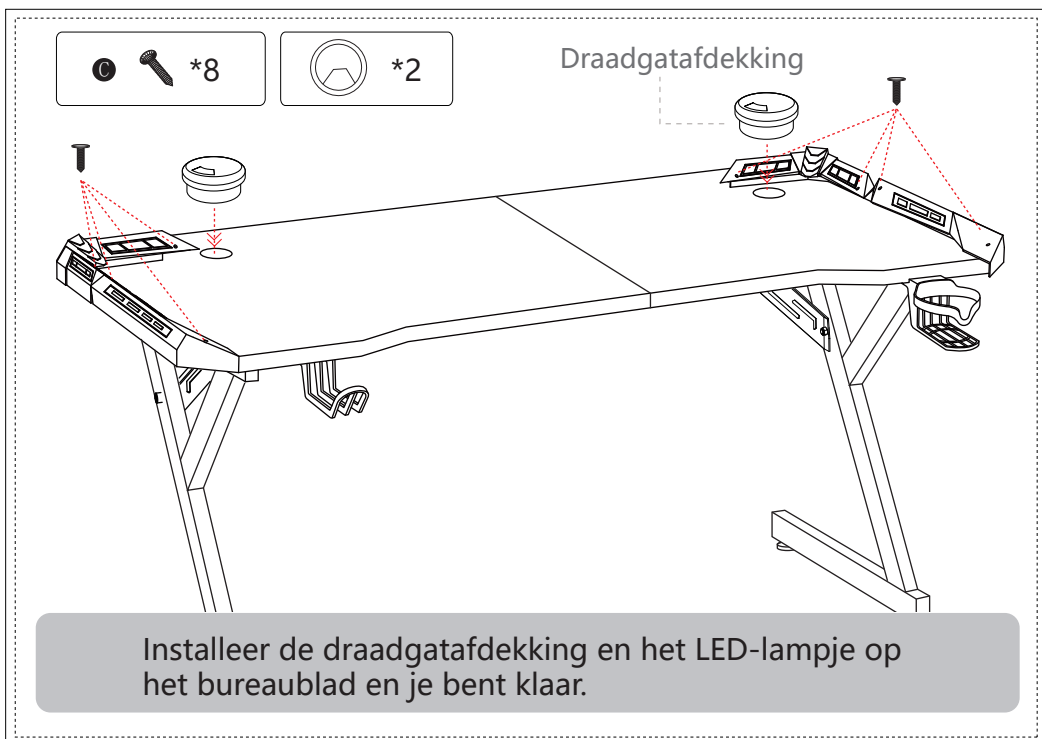
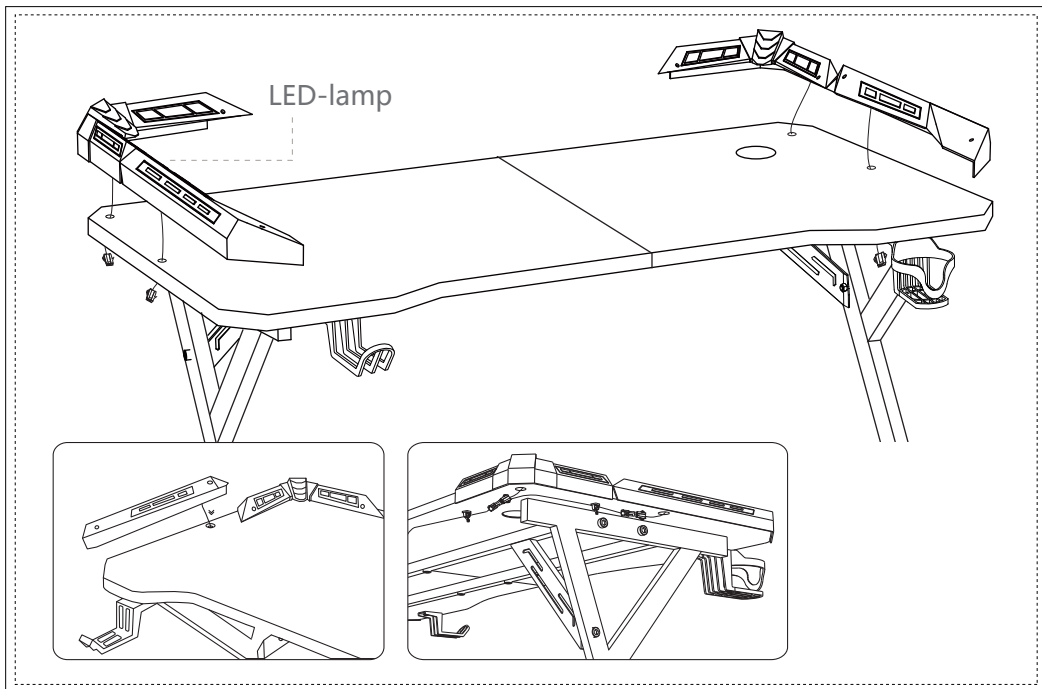

2枚の天板を固定する

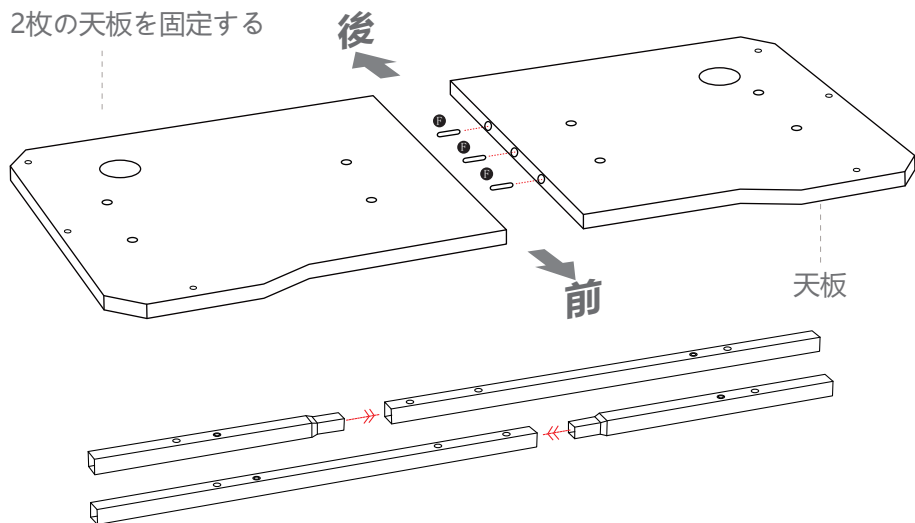

**!** 長いリーンフォースメントに短いリーンフォースメントを差し込みます。  
図のように取り付けてください。

**B**  30mm\*8

 \*8

ボルト (30mm)    ワッシャー

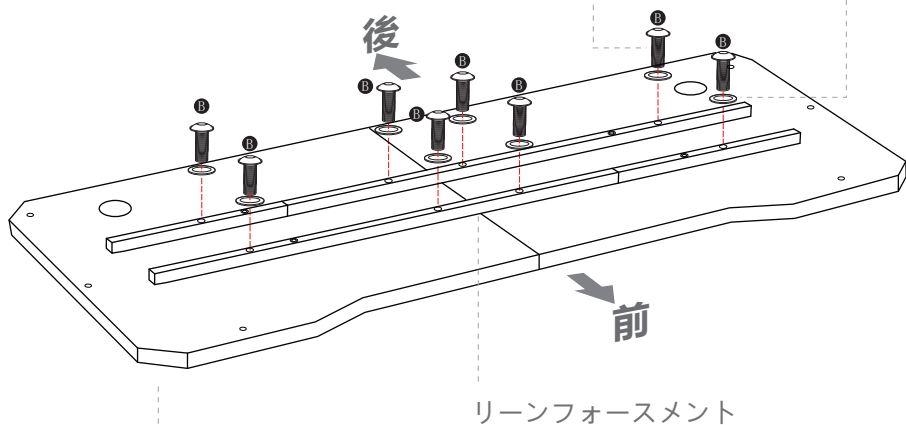

天板にフレームを取り付けます

  35mm\*4

 \*4

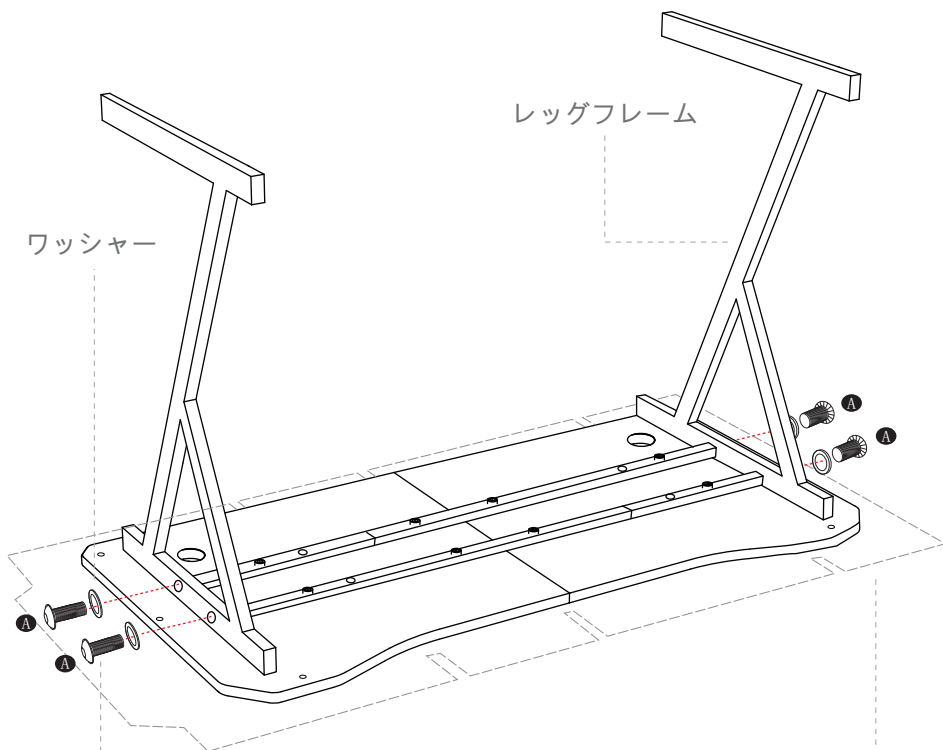

ボルト (35mm)

※ ゆるめに付けておきます。

梱包用の箱を床に平らに置いてマットとして使用することで、天板の表面が床と直接接触して摩耗するのを防ぐことができます。

**B**  30mm\*2

**D**  12mm\*2

 \*4

 \*2

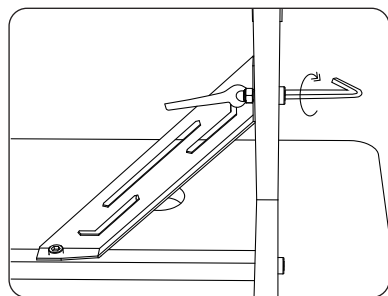
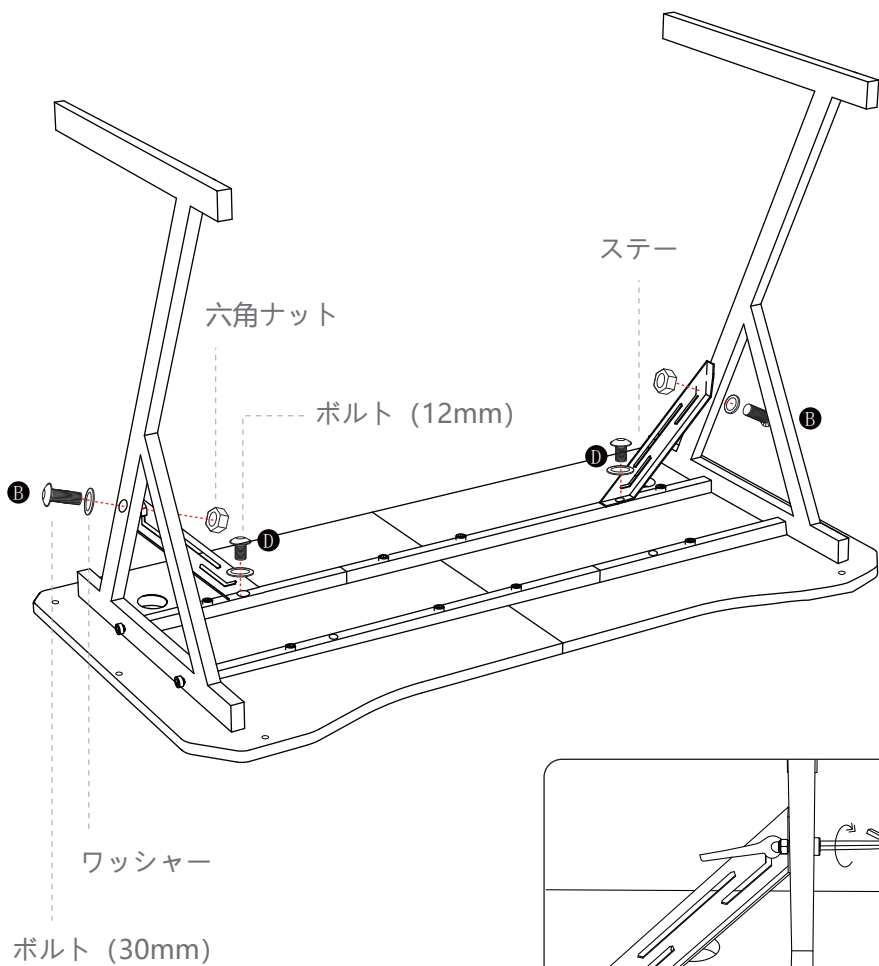

**!** 組立中ネジはあまりきつく締めないでください。特に注意して、全部のネジを入れるまで、しっかり締めないでください。

①  12mm\*2

 \*2

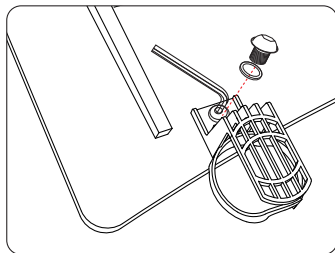
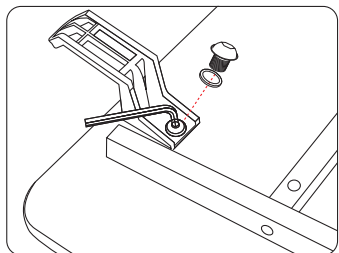
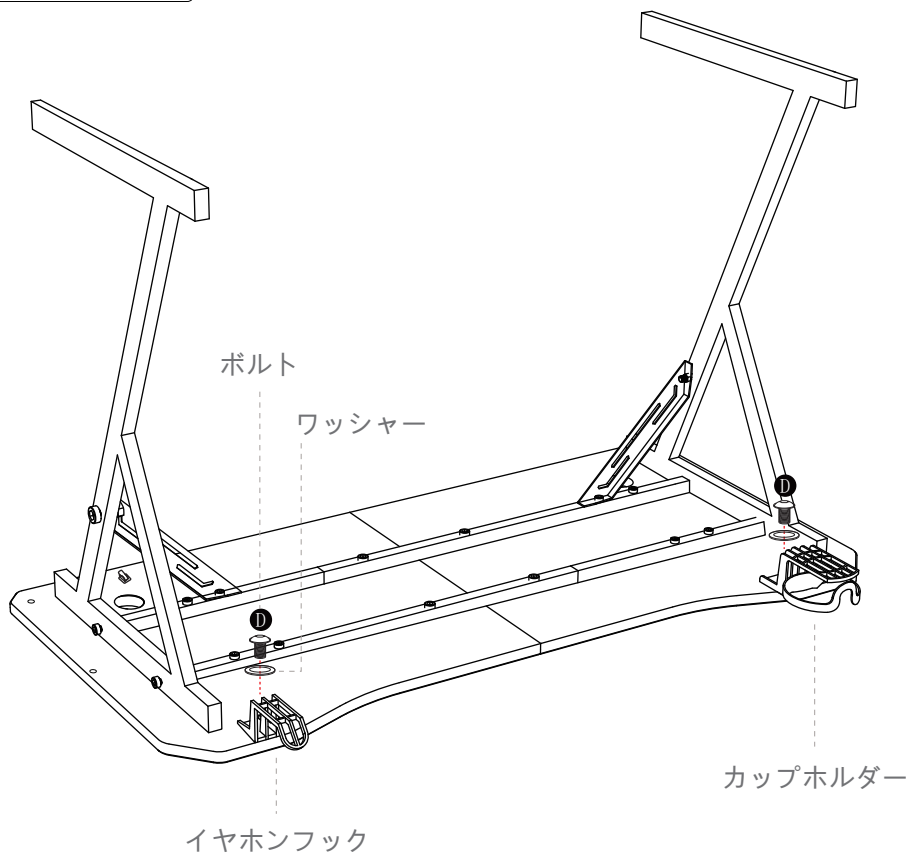

カップホルダーとイヤホンフックを取り付けます。

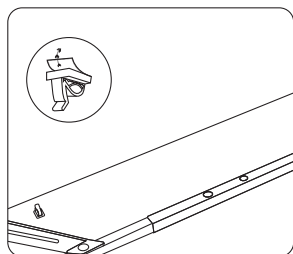
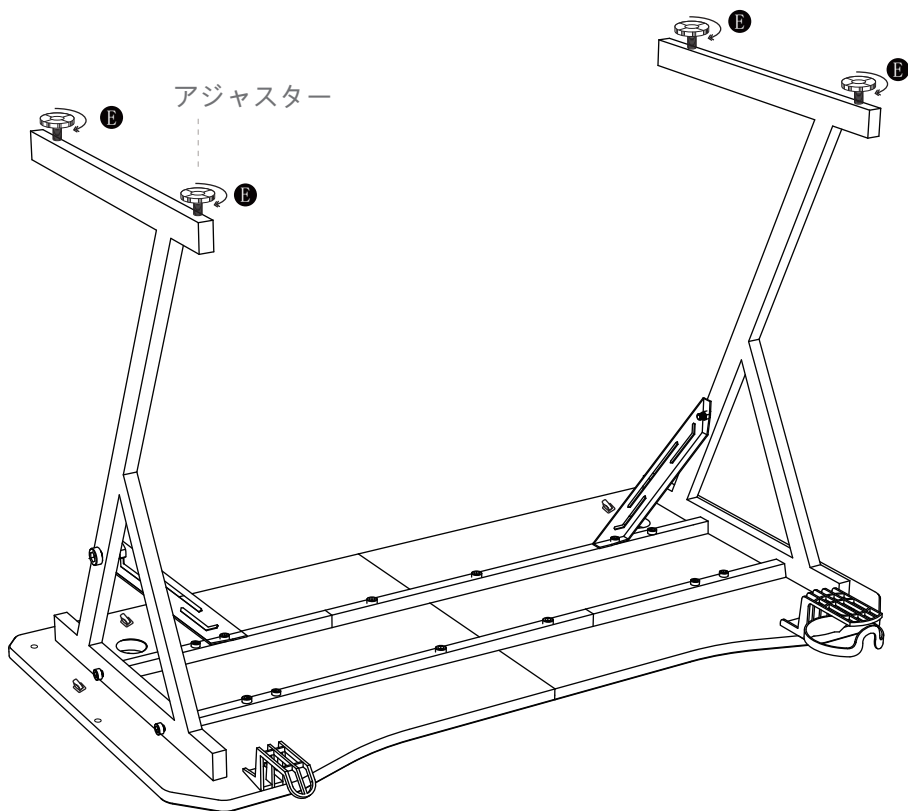
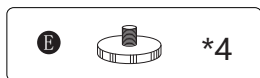

アジャスターを取付けます。

