

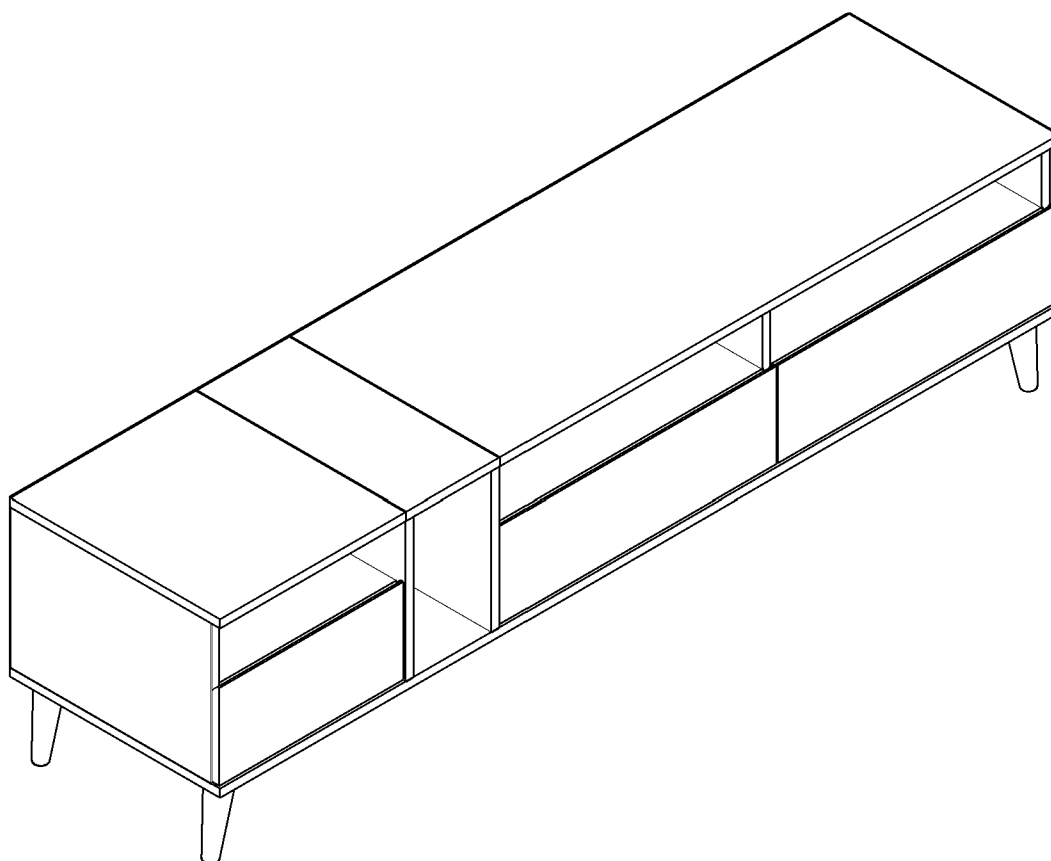

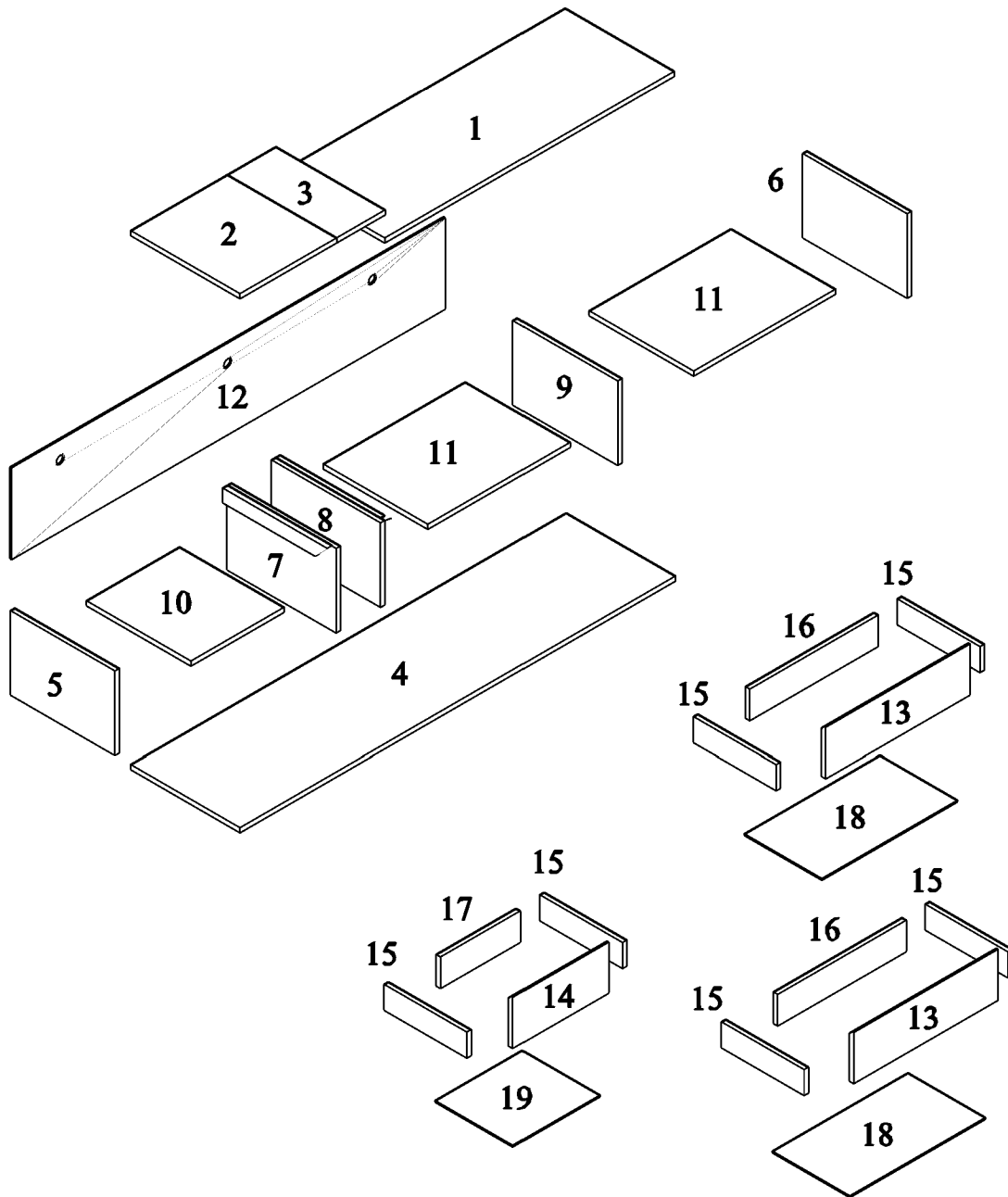

# ASSEMBLY INSTRUCTIONS





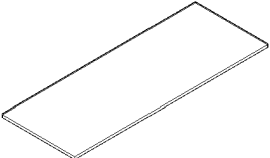
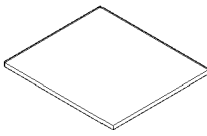
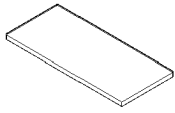
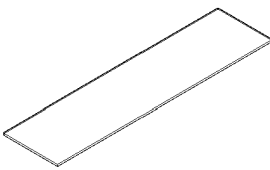
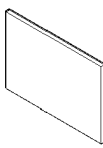
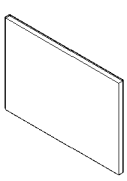
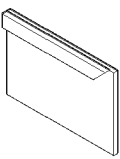
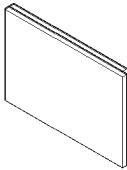
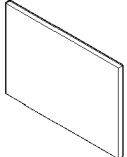
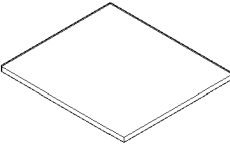
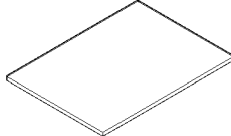
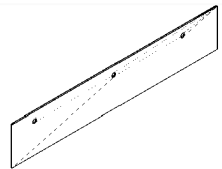

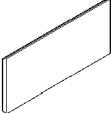
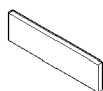
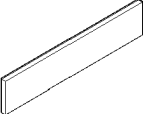

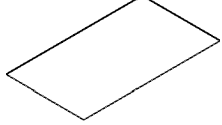
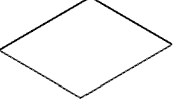
# Detail View

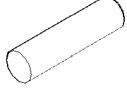
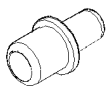

# Part List

<p>1</p>  <p>Long Top Panel - 1pc</p>	<p>2</p>  <p>Short Top Panel - 1 pc</p>	<p>3</p>  <p>Center Top Panel- 1 pc</p>
<p>4</p>  <p>Bottom Panel - 1 pc</p>	<p>5</p>  <p>Side Panel (Left) - 1 pc</p>	<p>6</p>  <p>Side Panel (Right) - 1 pc</p>
<p>7</p>  <p>Left Panel (Center) - 1pc</p>	<p>8</p>  <p>Center Panel - 1pc</p>	<p>9</p>  <p>Right Panel (Center) - 1pc</p>
<p>10</p>  <p>Short Shelf Panel - 1 pc</p>	<p>11</p>  <p>Long Shelf Panel - 2 pcs</p>	<p>12</p>  <p>Back Mdf Board - 1 pc</p>
<p>13</p>  <p>Drawer Face Panel (Long) - 2 pcs</p>	<p>14</p>  <p>Drawer Face Panel (Short) - 1 pc</p>	<p>15</p>  <p>Drawer Side Panel - 6 pcs</p>
<p>16</p>  <p>Drawer Back Panel (Long)-2 pcs</p>	<p>17</p>  <p>Drawer Back Panel (Short)-1 pc</p>	<p>18</p>  <p>Drawer Mdf Board Long- 2 pcs</p>
<p>19</p>  <p>Drawer Mdf Board Short - 1 pc</p>		

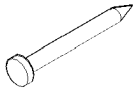
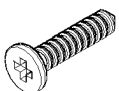
# Hardware List

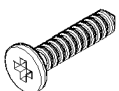

<b>A</b> 	<b>B</b> 	<b>C</b> 
Cam Pin M5x24MM (14 pcs)	Cam Lock (14 pcs)	Wood Dowel M8X30MM(24 pcs)
<b>D</b> 	<b>E</b> 	<b>F</b> 
Iron Shelf Support (12 pcs)	Drawer Slide 14" (3 sets)	Screw M6x50MM (10 pcs)
<b>G</b> 	<b>H</b> 	<b>I</b> 
Screw M4x38MM (24 pcs)	Power Pin (30 pcs)	Screw M3.5x16MM (28 pcs)
<b>J</b> 	<b>K</b> 	<b>L</b> 
Round Taper Leg (6 pcs)	Allen Key (1 pc)	Screw M3.5x12MM (36 pcs)

## ASSEMBLY TOOLS REQUIRED ( NOT INCLUDED )



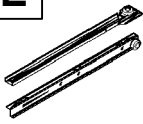

PLEASE BE CAREFUL DO NOT DAMAGE THE HOLE POSITION WHEN YOU USE POWER TOOLS !

**STEP 1 :**

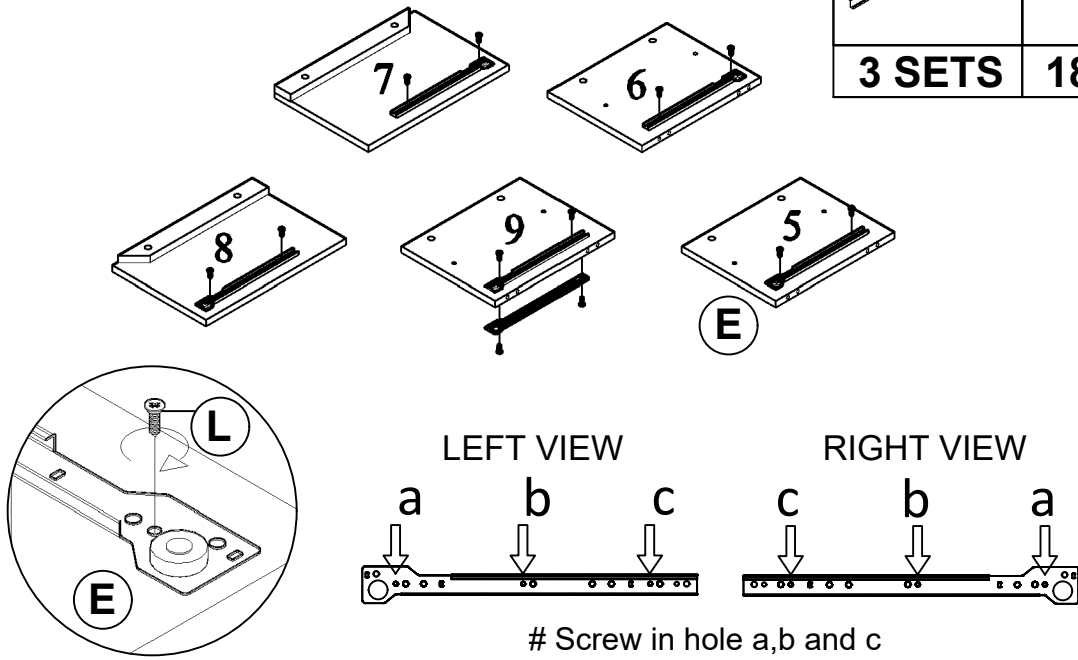
<b>E</b>		<b>L</b>	
<b>3 SETS</b>		<b>18 PCS</b>	

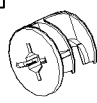
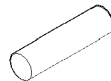

**STEP 2 :**

<b>B</b>		<b>C</b>		<b>D</b>	
<b>14 PCS</b>		<b>24 PCS</b>		<b>12 PCS</b>	

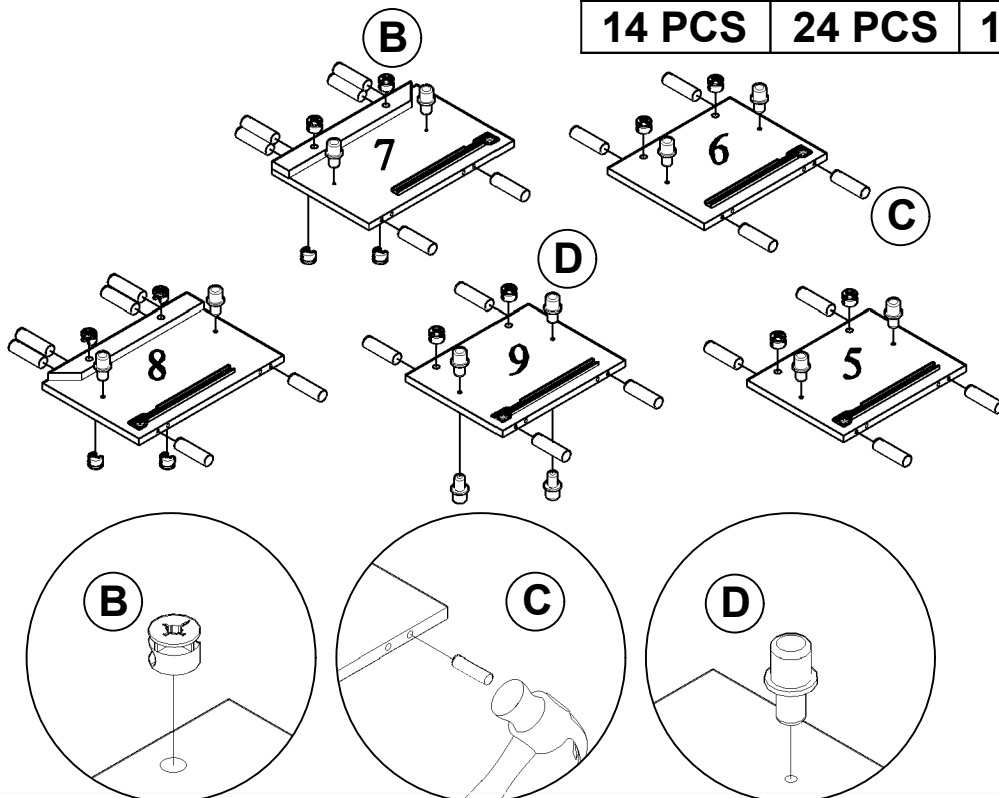

**STEP 3 :**

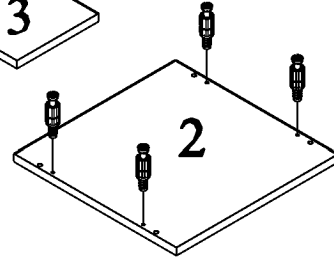
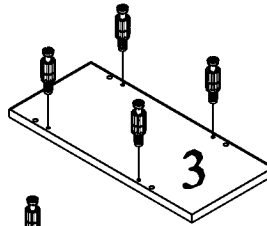
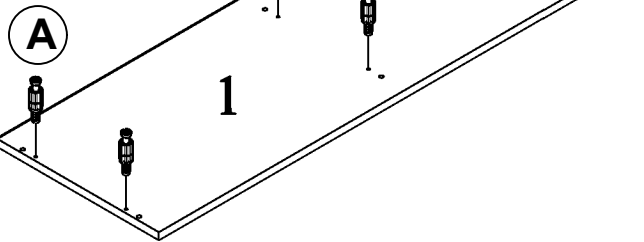
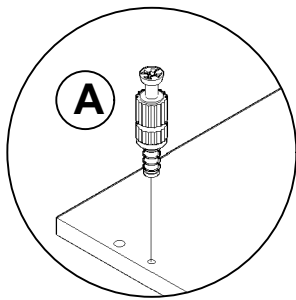

**A**

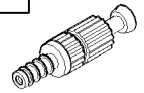

**14 PCS**

**STEP 4:**

**F**



**10 PCS**

**K**



**1 PC**

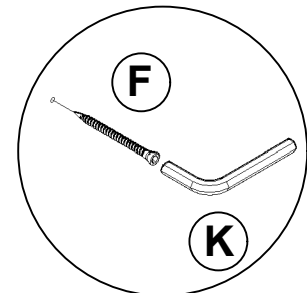
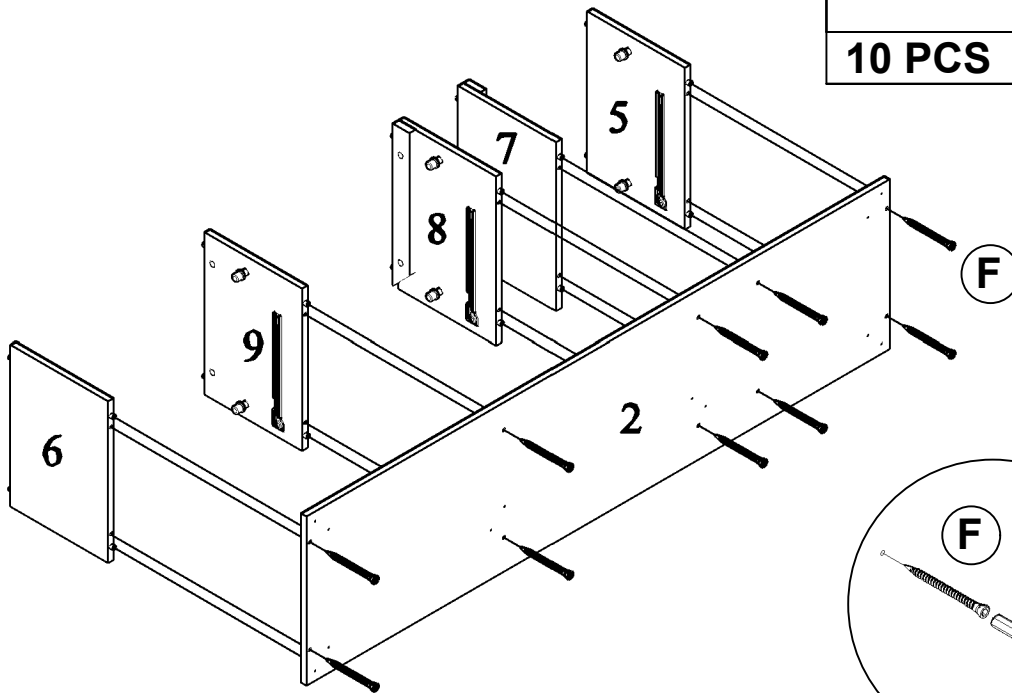

STEP 5 :

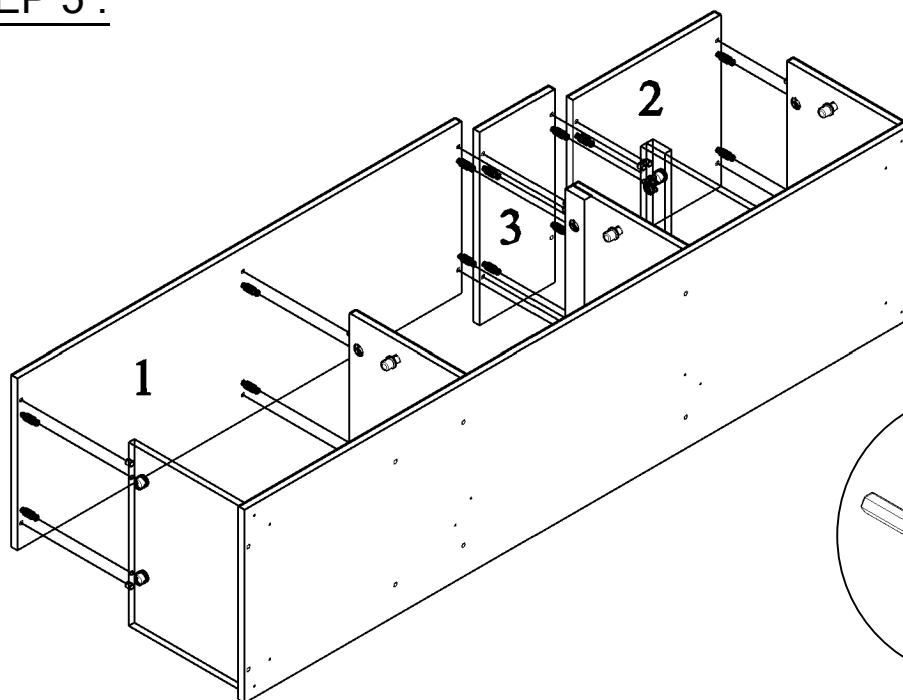

**K**



**1 PC**

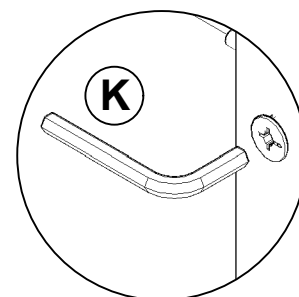

STEP 6 :

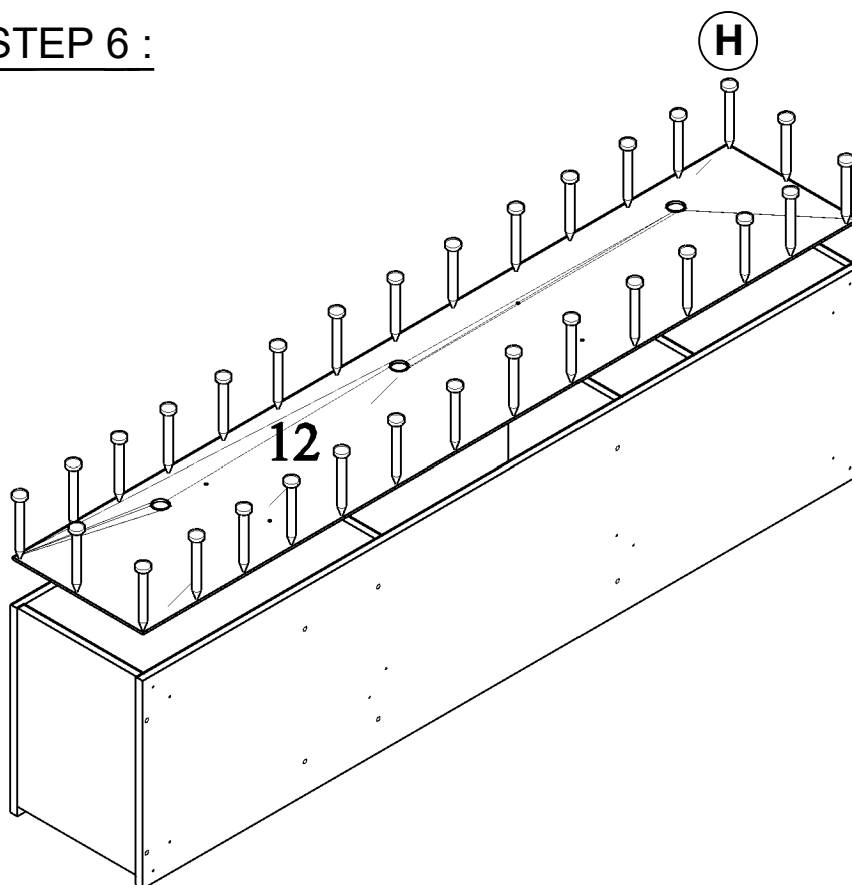

**H**

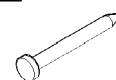

**30 PCS**

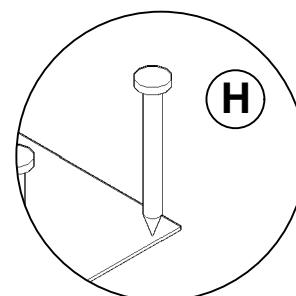

**STEP 7 :**

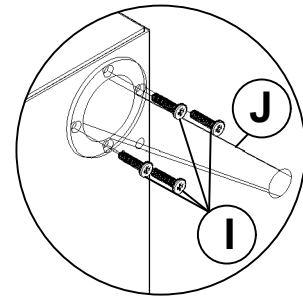
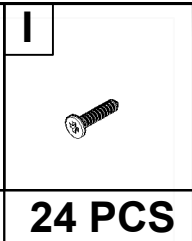
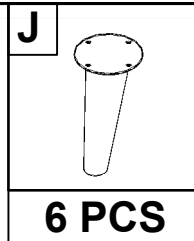
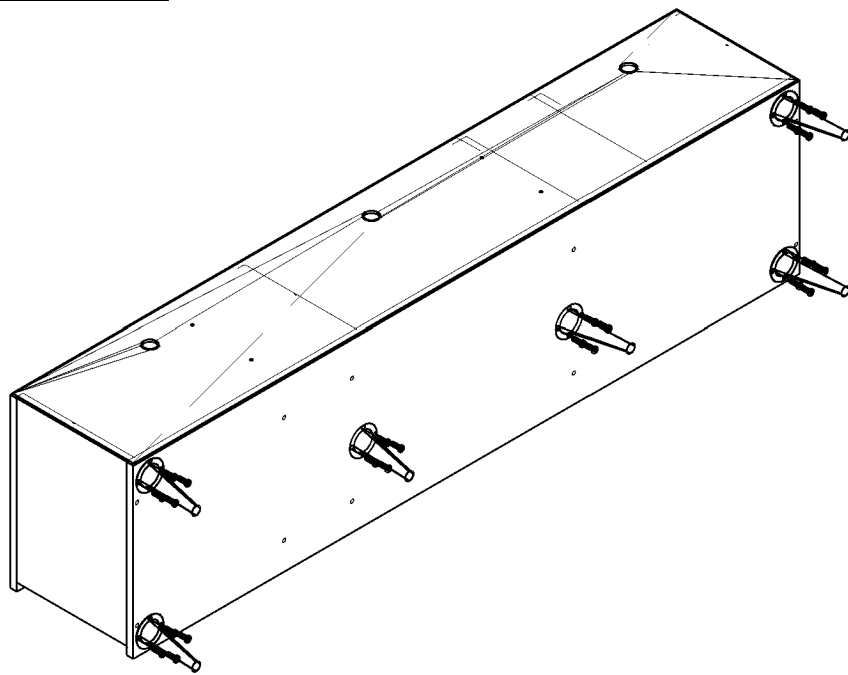

**STEP 8 :**

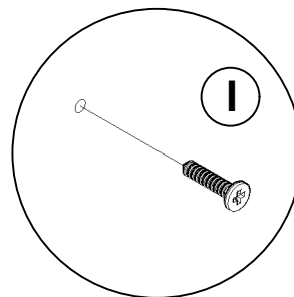
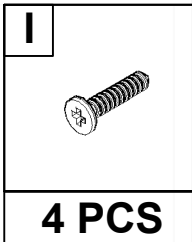
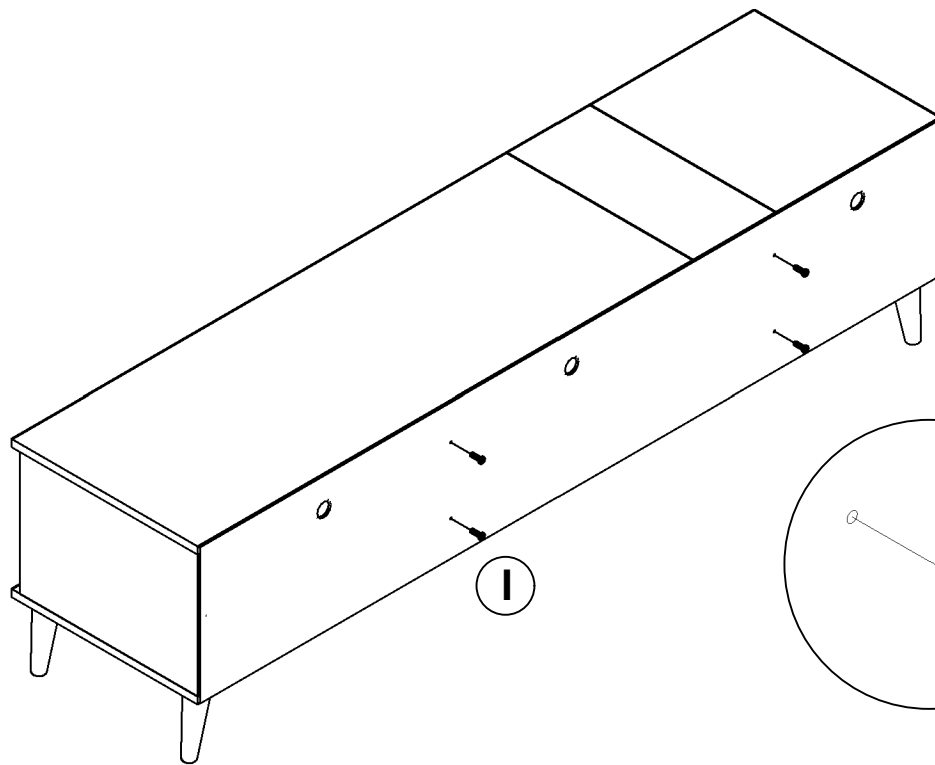

STEP 9 :

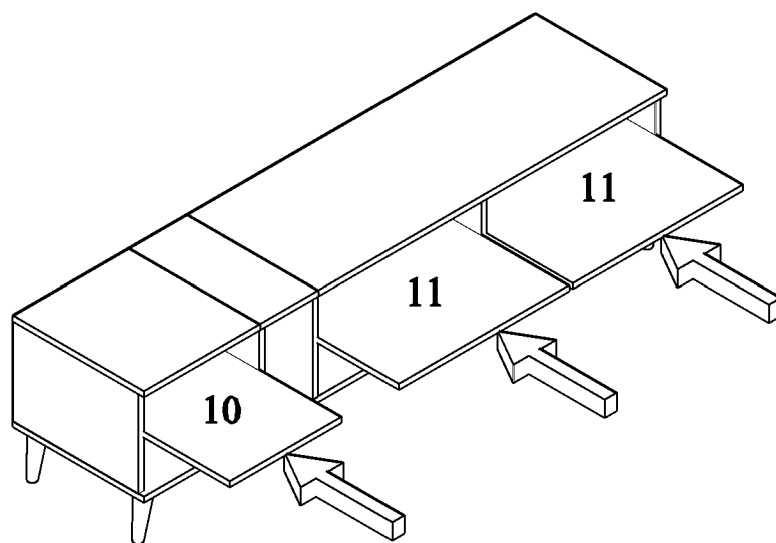

STEP 10 :

**G**



**24 PCS**

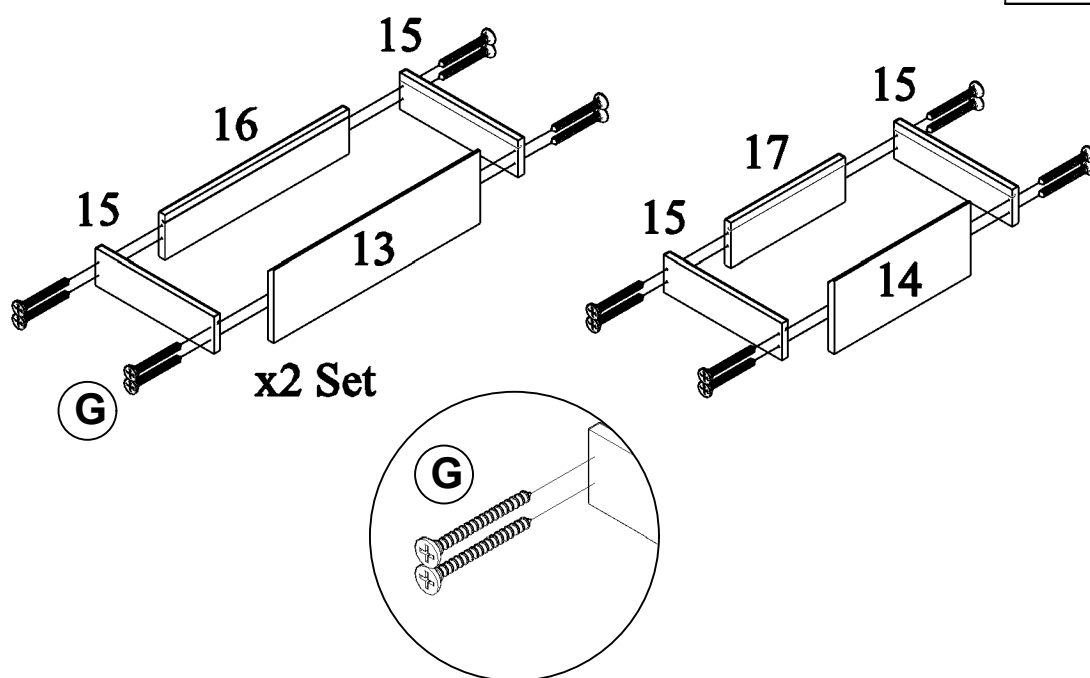

**STEP 11:**

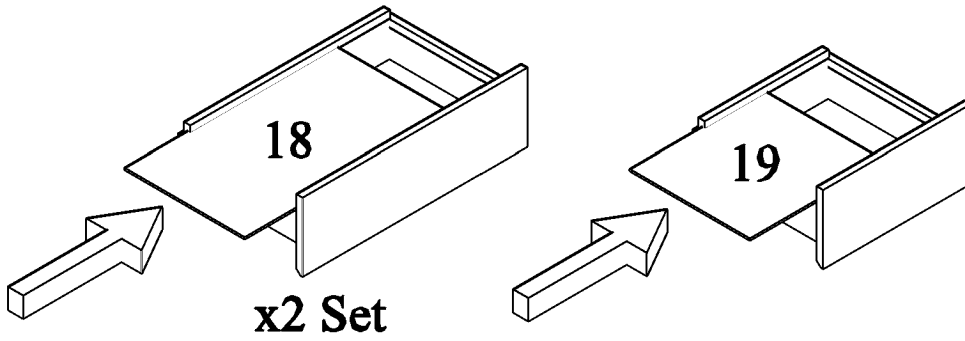

**STEP 12 :**

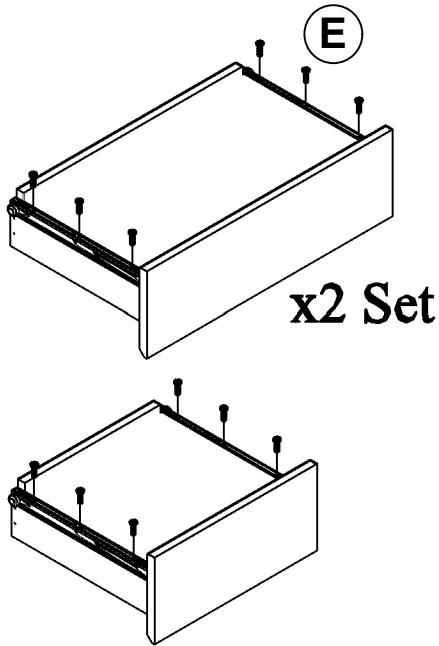

E	L
3 SETS	18 PCS

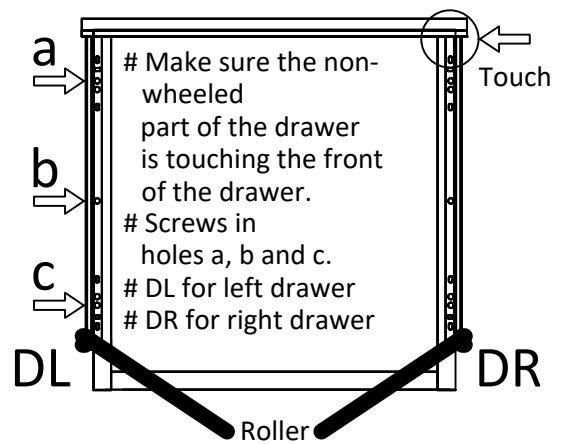
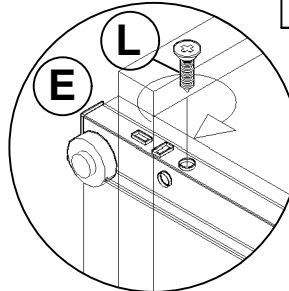

STEP 13 :

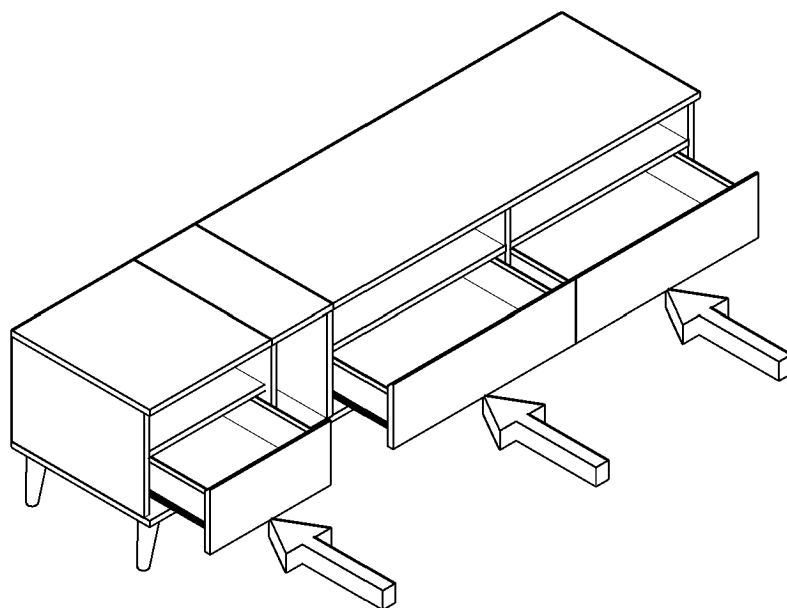

COMPLETE :

