

# ASSEMBLY INSTRUCTIONS

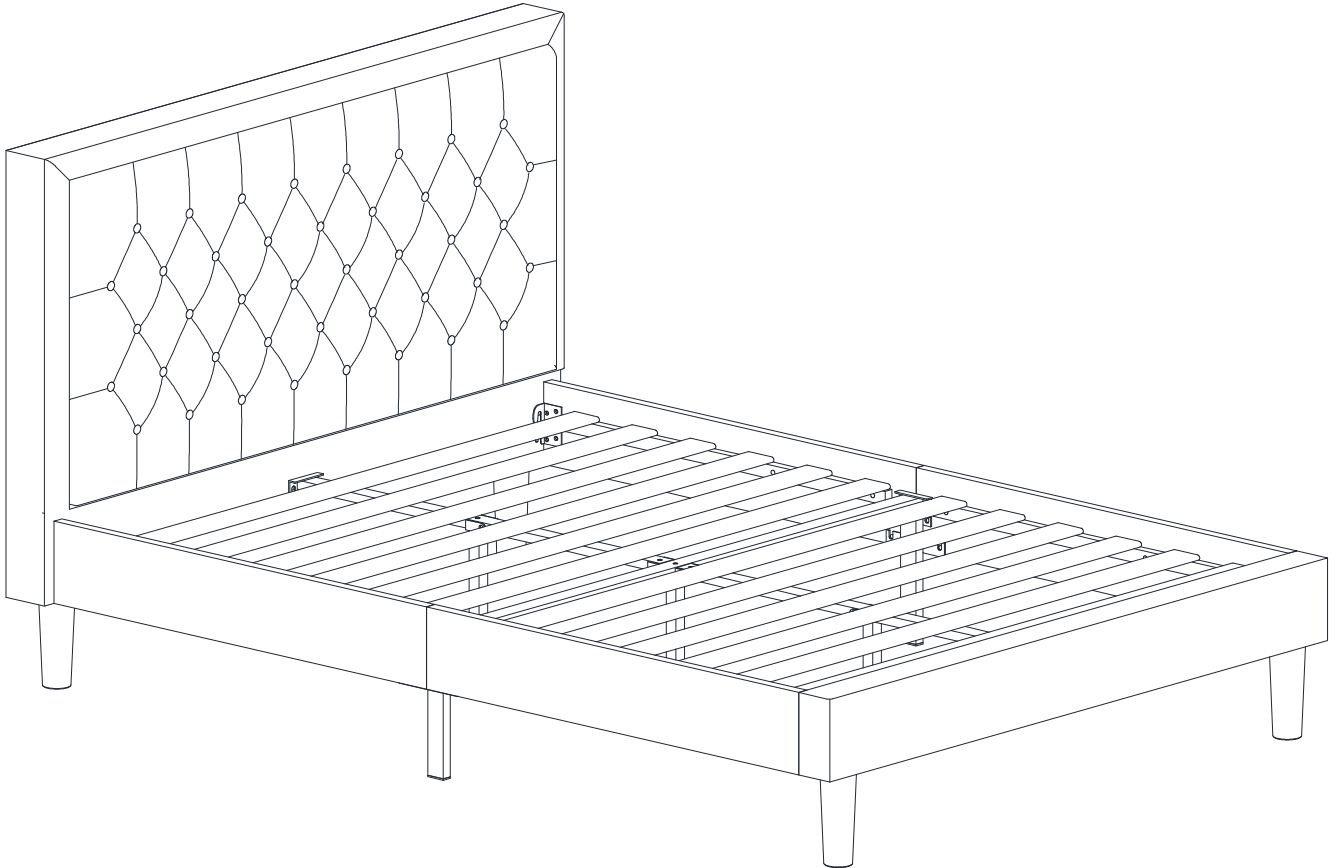

**Product** Dimension : 59"Wx83.6"Lx47"H

(FULL BED)

Cube Size : 61"x41.7"x6.6"

NW: 95.7 LBS

GW: 103.4 LBS

**Product** Dimension : 65"Wx88.7"Lx47"H

(QUEEN BED)

Cube Size : 66.8"x41.7"x6.6"

NW: 105.6 LBS

GW: 114.4 LBS

## BEFORE ASSEMBLY

Thank you for purchasing this quality product. This product has been designed for easy assembly and constructed for durability. Please take the time to read and follow the assembly instructions carefully.

Be sure to check all packing material carefully for small parts which may have come loose inside the carton during shipment. Please separate, identify, and count all parts and metal hardware. Compare with part list to be sure all parts are present.







If hardware is missing or you have difficulty assembling this product, please call for us.

**IMPORTANT NOTE:**

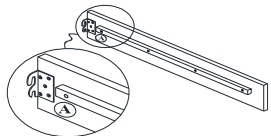
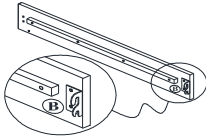
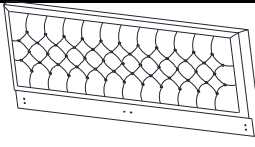
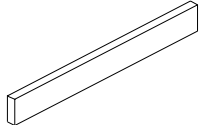
- Place all wooden parts on a clean and smooth surface such as a rug or carpet to avoid the parts from being scratched.
- Remove all wrapping material, including staples & packing straps before you start to assemble.
- DO NOT tighten all screws and bolts until completely assembled.
- Keep all hardware parts out of reach of children.

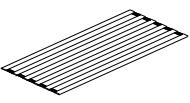

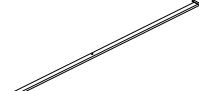

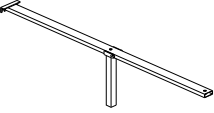

## PART LIST

When unpacking, please be careful not to discard any parts with the packaging. Before continuing, please make sure you have the following parts:

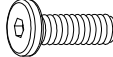
NO	Description	Qty	Sketch	NO	Description	Qty	Sketch
A	Side rails	2		B	Side rails	2	
C	Headboard	1		D	Footboard	1	
E	Leg	4		F	Slats	2	
G	Center suport Leg	2		H	Horizontal support frame	1	
K	U-bracket	1		L	Center Support Rail	2	

## HARDWARE LIST

When unpacking, please be careful not to discard any parts with the packaging. Before continuing, please make sure you have all of the following hardware:

NO	Description	Qty	Sketch	NO	Description	Qty	Sketch
1	Medium bolt (M8x20mm)	8		2	Short bolt (M6x15mm)	16	
3	Long bolt (M6x30mm)	5		4	Large lock washer (Φ8.5xΦ13mm)	8	
5	Large flat washer (Φ8.5xΦ19mm)	8		6	Allen key	1	

## STEP 1

Attach the legs (E) to the bottom of the headboard (C). as shown below.

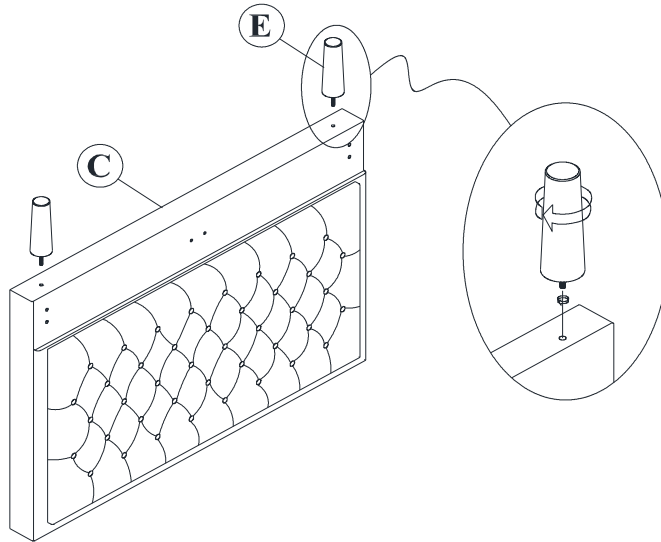

## STEP 2

Attach the legs (E) to the bottom of the footboard (D). as shown below.

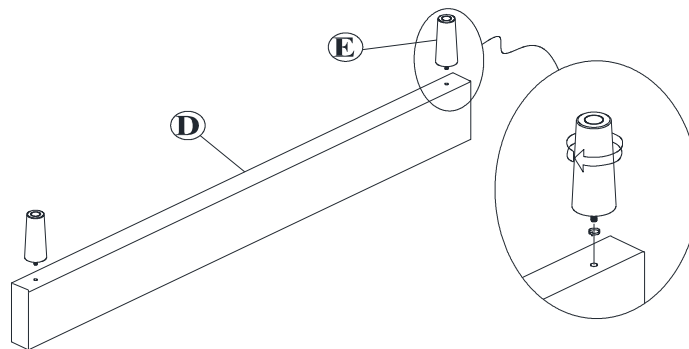

## STEP 3

Assemble the left side rails by joining the (A) & (B) side rail pieces in the center to the horizontal support rail using the bolts (2) provided. Assemble the right side rails by joining the (A) & (B) side rail pieces in the center to the horizontal support rail using the bolts (2). Tighten with Allen key (6).

NOTE: Make sure the pre-assembled woot slat support pieces are toward the top of the side rails so the slats can rest evenly.

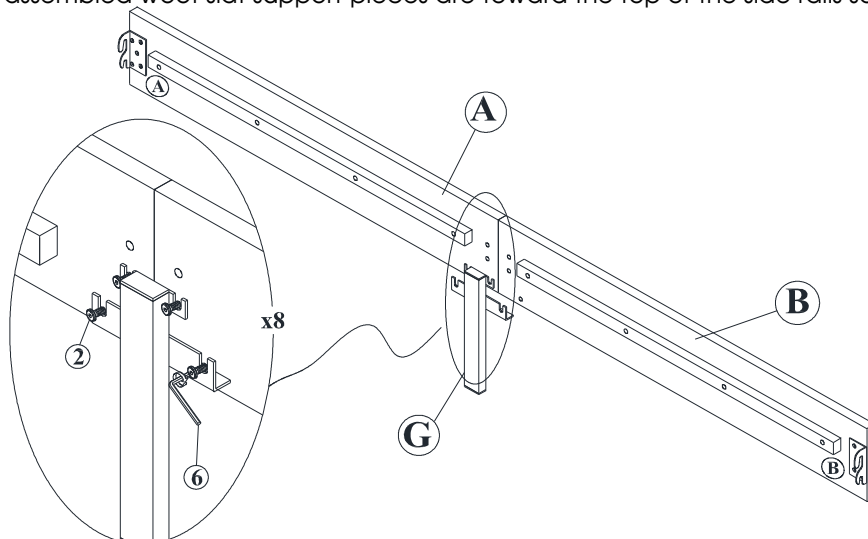

## STEP 4

Attach the Headboard to the assemble side rails using the bolts (1) and washers (4) and (5) on the both sides. Repeat for the Footboard. Tighten with Allen key (6).

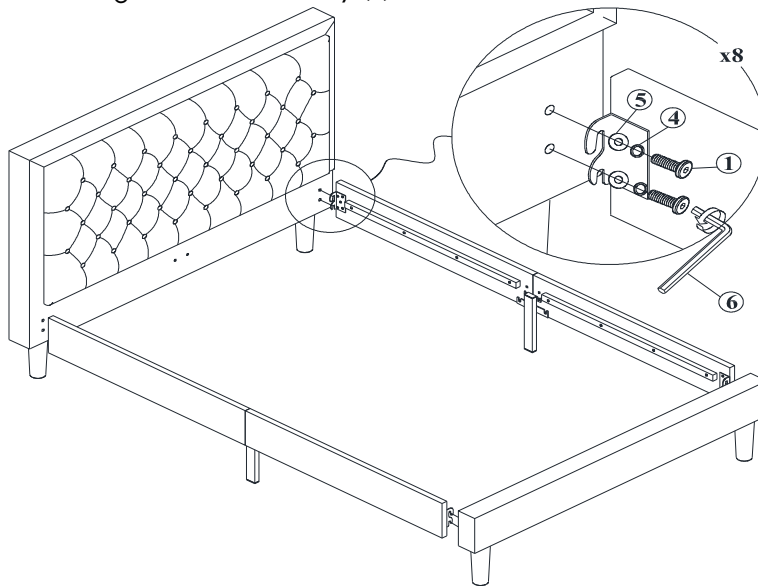

## STEP 5

Attach U-bracket (K) to the Horizontal support frame (H) using the bolts (6) Tighten with Allen key (6)

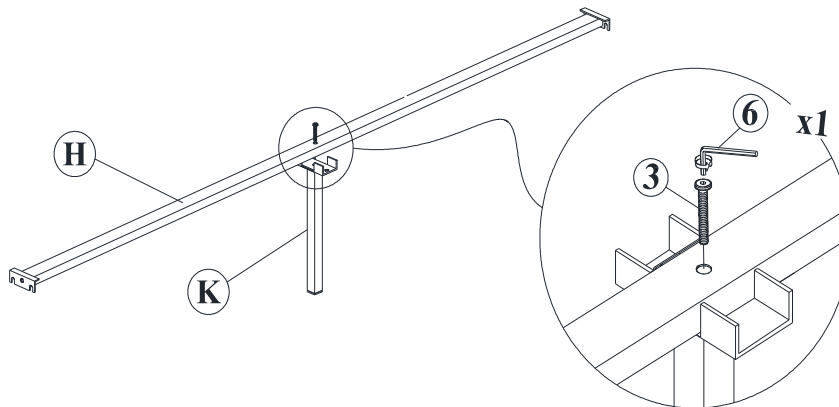

## STEP 6

Attach the Horizontal support frame (on step 4) using the bolts (2) Tighten with Allen key (6)

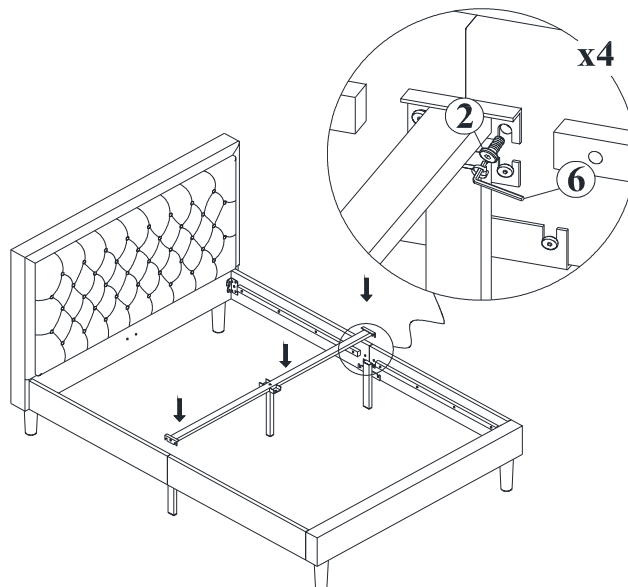

## STEP 7

Attach Center Support Rail (L) to Headboard & footboard (on step 6) using the bolts (2) & bolts (3) Tighten with Allen key (6)

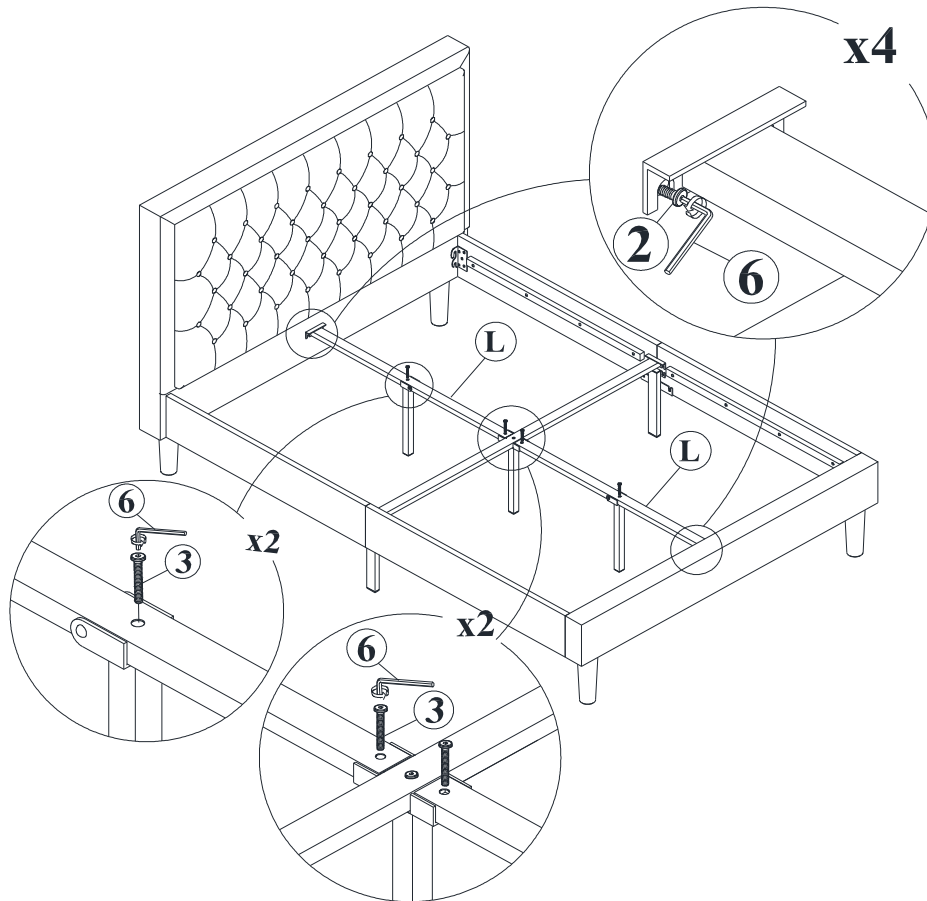

## STEP 8

Place the straight slats on top, and enjoy your new bed frame!

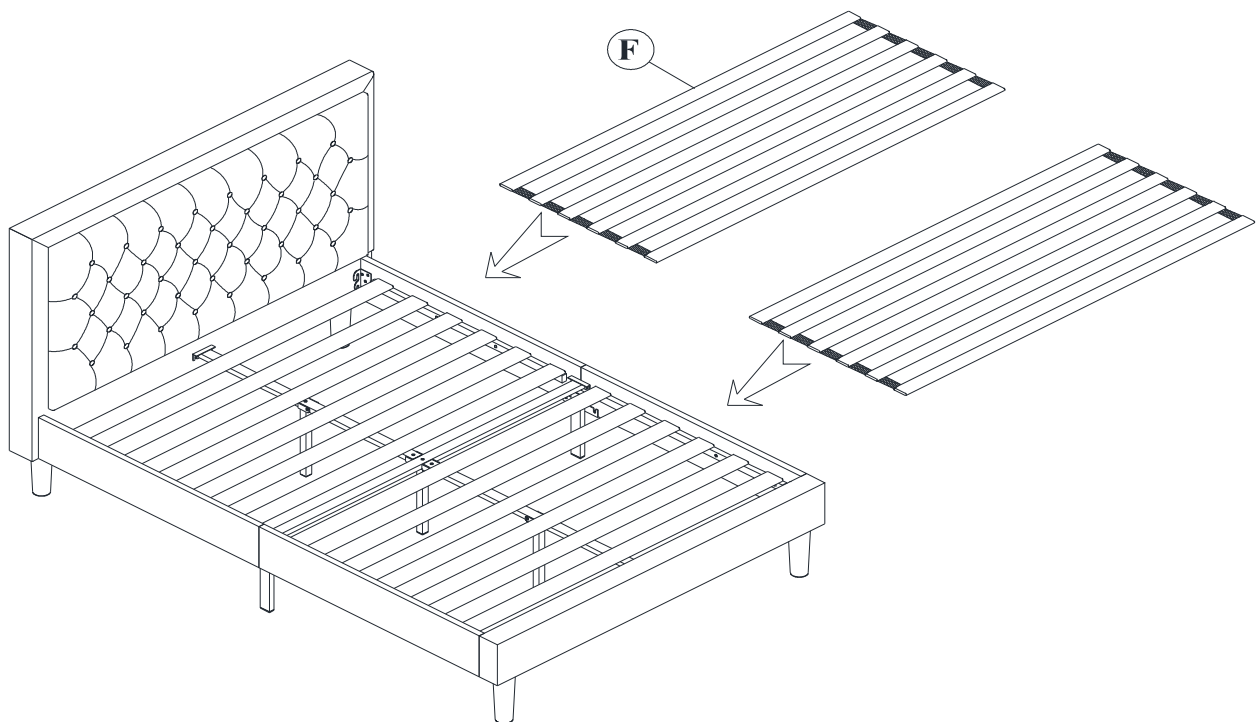

# ASSEMBLY INSTRUCTIONS

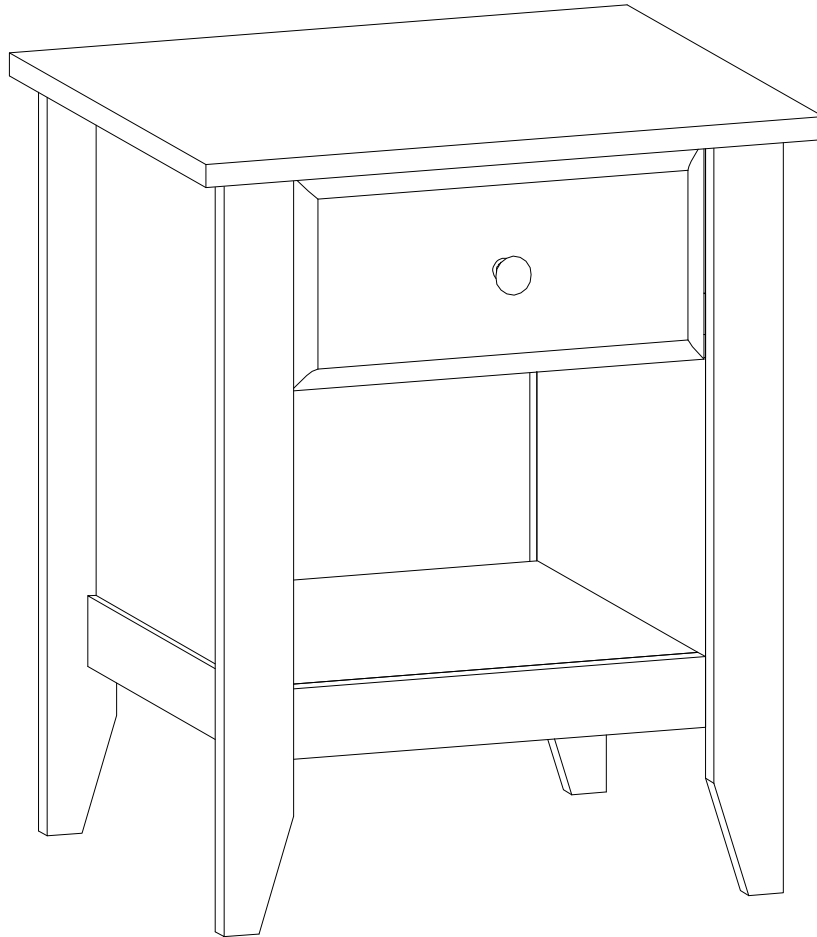

Product Dimension : 21"x18"x24"

Cube Size : 25"x19.6"x14.3"

NW: 28.6 LBS

GW: 33 LBS

## BEFORE ASSEMBLY

Thank you for purchasing our product. This product has been designed for easy assembly and long lasting use. Please take the time to read and follow the assembly instructions carefully.

Be sure to check all packing material carefully for small parts that may have come loose inside the carton during shipment. Please separate, identify, and count all parts and metal hardware. Compare with the part list to be sure all parts are present. If the hardware is missing or you have difficulty assembling this product, please call for us.

**IMPORTANT NOTE:**

- Place all wooden parts on a clean and smooth surface such as a rug or carpet to avoid the parts from being scratched.
- Remove all wrapping material, including staples & packing straps, before you start to assemble.
- DO NOT tighten all screws and bolts until completely assembled.
- Keep all hardware parts out of reach of children.





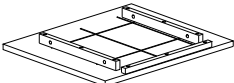
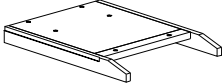
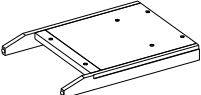
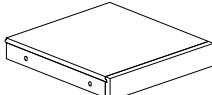
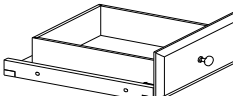
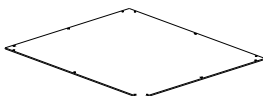

## PART LIST

When unpacking, please be careful not to discard any parts with the packaging. Before continuing, please make sure you have the following parts:

NO	Description	Qty	Sketch	NO	Description	Qty	Sketch
A	Top	1		B-R	Right foot cluster	1	
B-L	Left foot cluster	1		C	Shelf	1	
D	Drawer Frame	1		E	Rear Panel		

## HARDWARE LIST

When unpacking, please be careful not to discard any parts with the packaging. Before continuing, please make sure you have all of the following hardware:

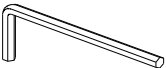
NO	Description	Qty	Sketch	NO	Description	Qty	Sketch
1	Bolt (M6x30mm)	12		2	Screw (M6x15mm)	12	
3	Lock washer (6.5x9mm)	12		4	Flat washer (6.5x19mm)	12	
5	Allen key (M4)	1					

## STEP 1

Remove the drawer from the bracket (D) as shown below.

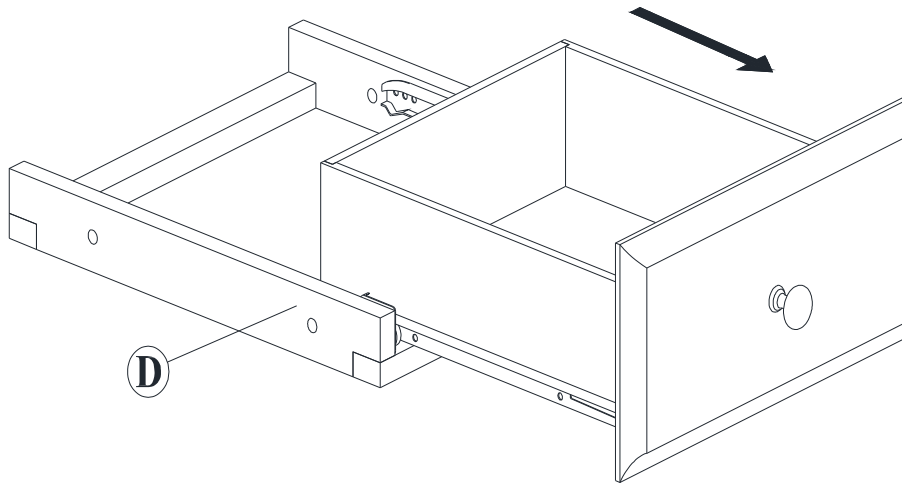

## STEP 2

Attach side (A), Shelf (C) and drawer bracket (D) to right foot assembly (B-R) respectively with bolts (1) and Lock washers (3), washers (4). Tighten with Allen key (5).

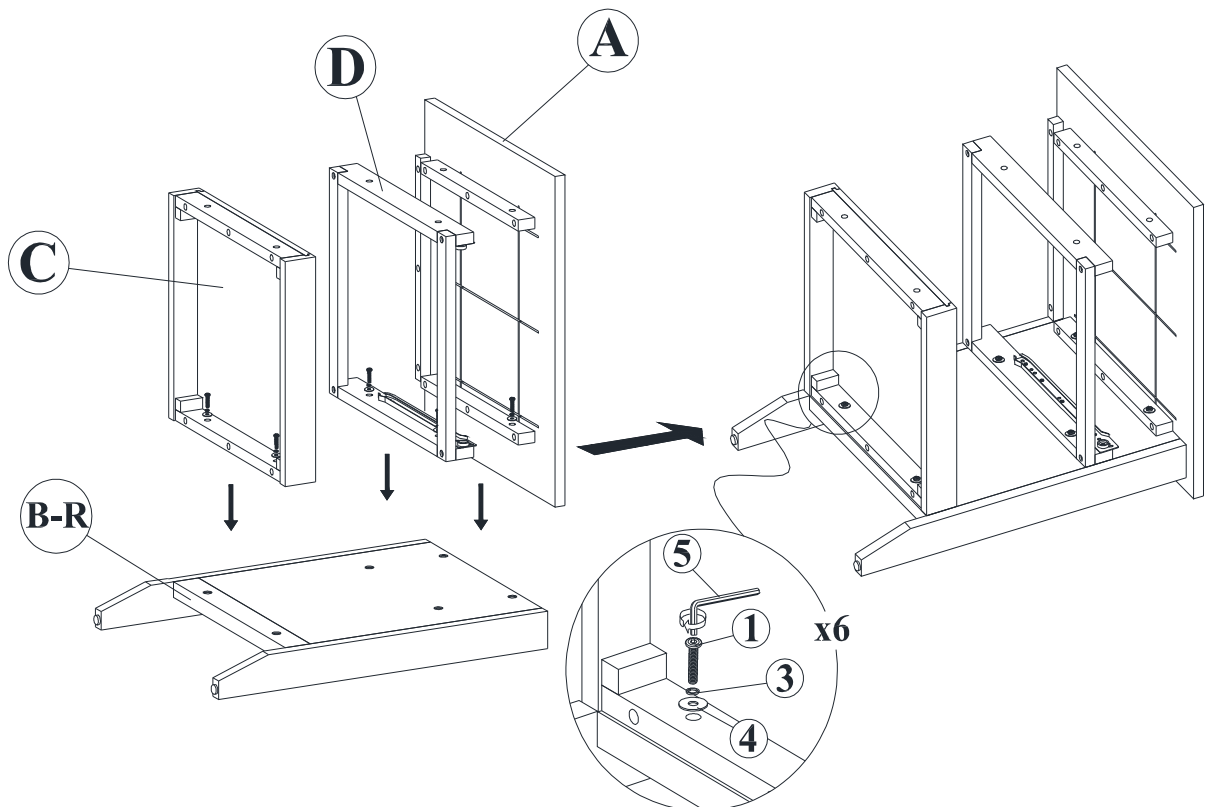

## STEP 3

Attach the left foot (B-L) to the completed assembly in step 2 with Bolts (1) and Lock washers (3), washers (4). Tighten with the Allen Key (5).

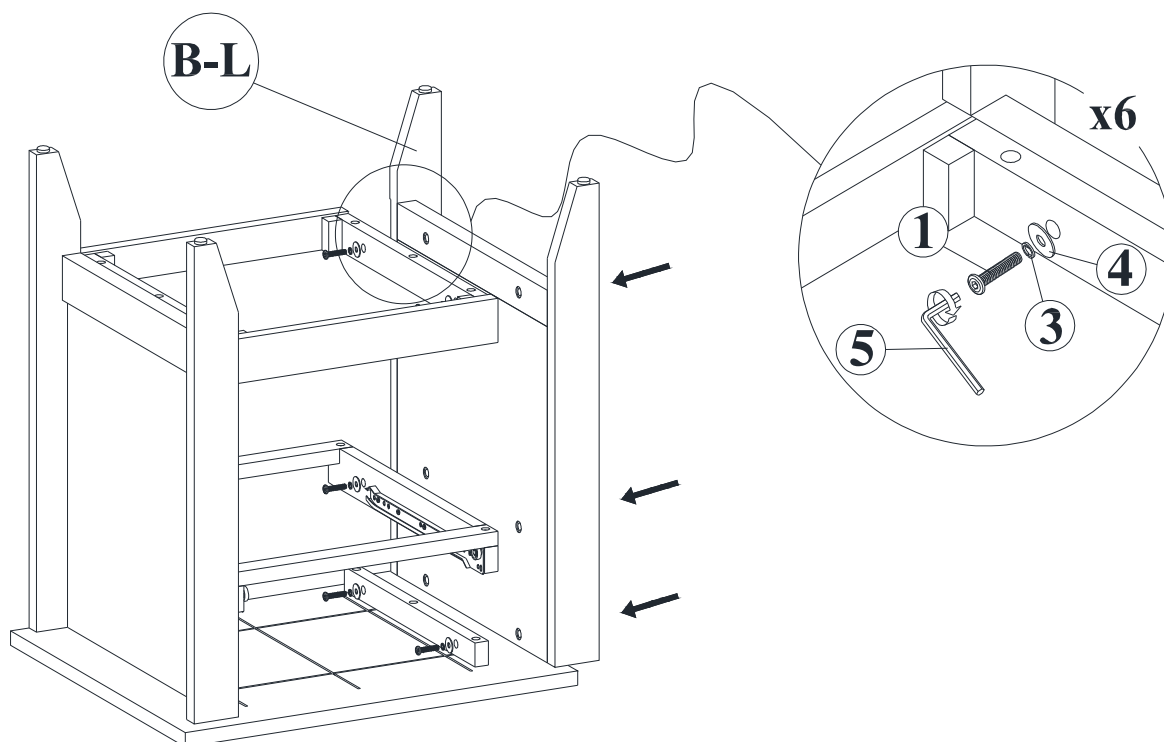

## STEP 4

Slide Drawer in to the chest as shown below.

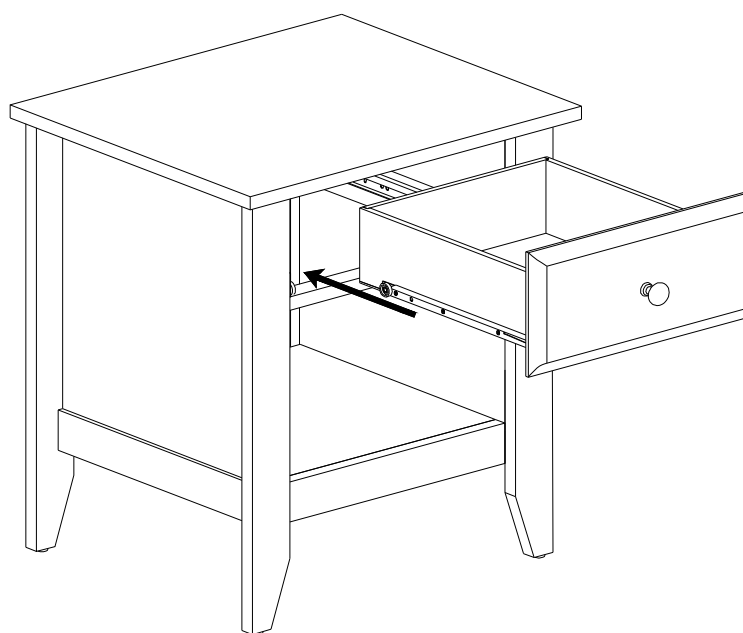

## STEP 5

Attach the rear panel (E) to the rear of the completed assembly in step 3 with screw (2) use the screw driver to tighten the screws (2). as shown below.

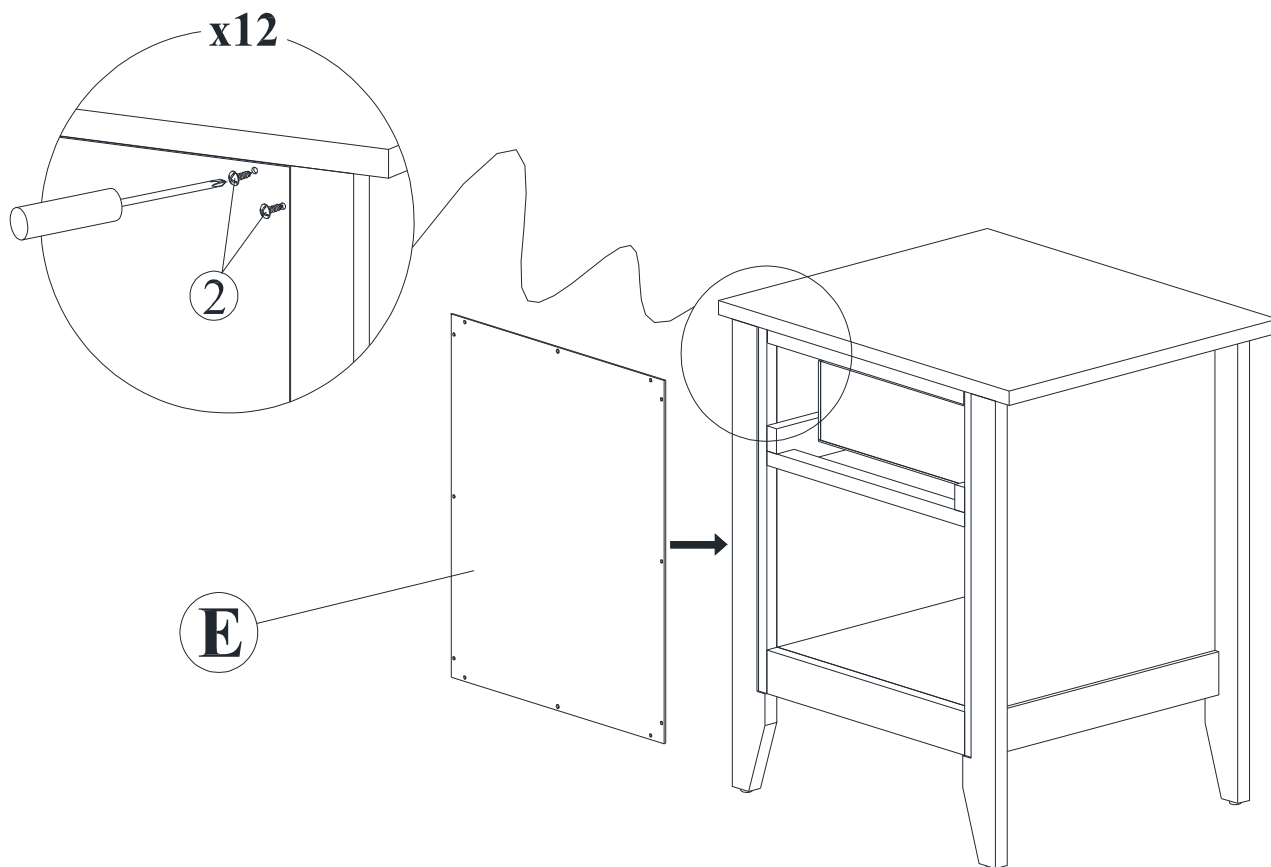

## STEP 6

complete the assembly

