

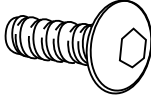

# Assembly Instructions

Part	Drawing	Part Name	Qty.	Part	Drawing	Part Name	Qty.
<b>A</b>		Seat Frame	<b>1</b>	<b>C</b>		Bolt	<b>4</b>
<b>B</b>		Back Frame	<b>1</b>	<b>D</b>		Allen Wrench	<b>1</b>

Step 1 - Remove all parts from their packaging and confirm that the quantities match those listed above.

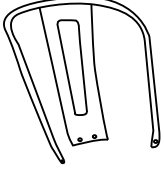

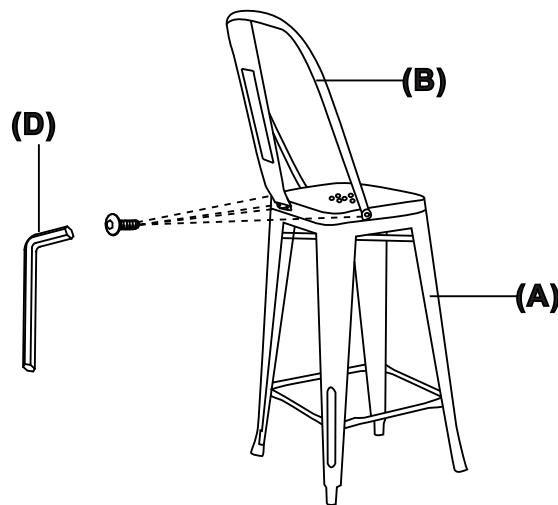
Step 2 -Set the Seat Frame (Part A) upright and align the bolt holes on the Back Frame (Part B) with the threaded inserts in the Seat Frame. Insert one Bolt (Part C) through each of the bolt holes in the Back Frame and into the threaded inserts in the Seat Frame. Tighten the Bolts using the Allen Wrench (Part D). Do not over tighten the Bolts.

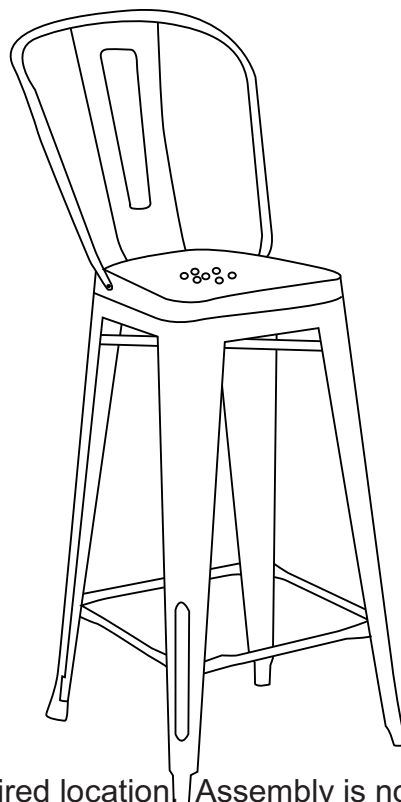

Step 3 -Move the Bar Stool to the desired location. Assembly is now complete.