

Assembly Instructions

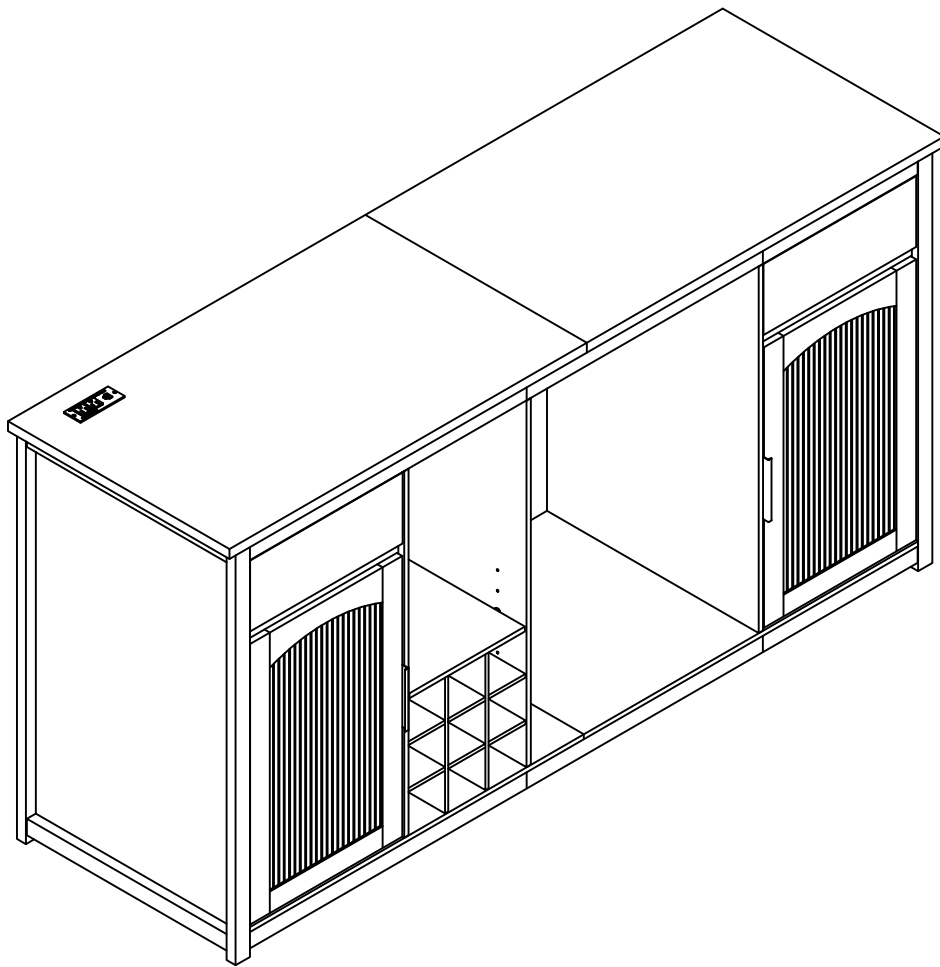

We come with the necessary tools for assembly,
but for faster assembly, a power drill is recommended.

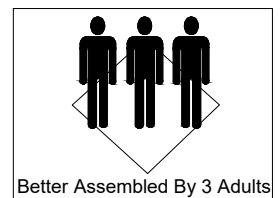



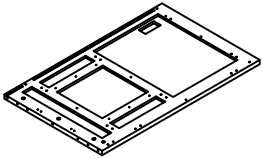
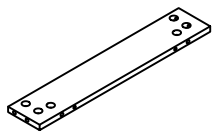
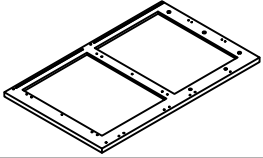
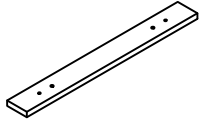
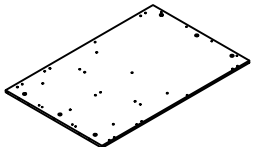
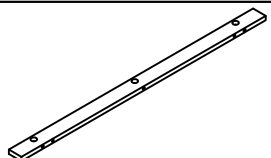
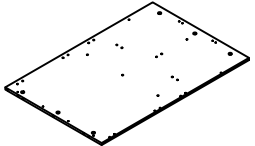
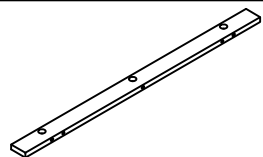
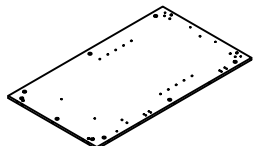
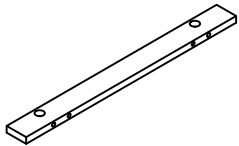
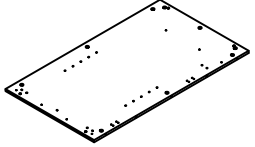
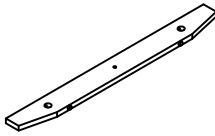
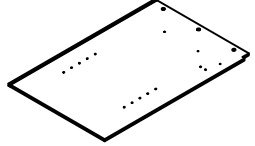
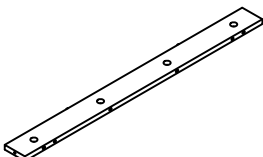
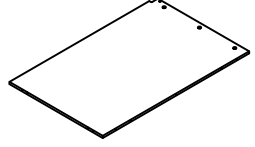
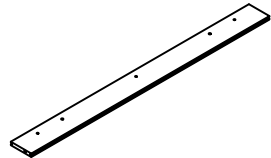
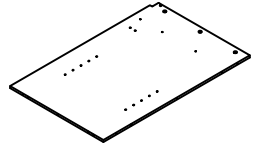
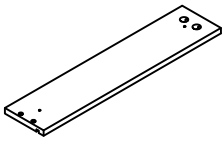
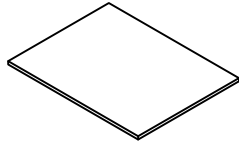
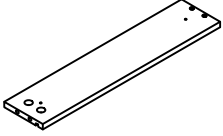
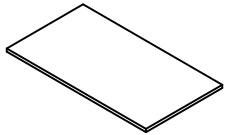
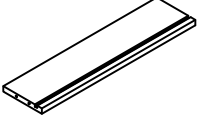



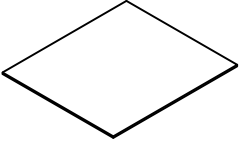
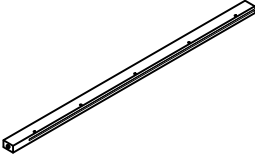
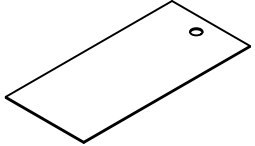
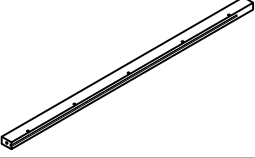
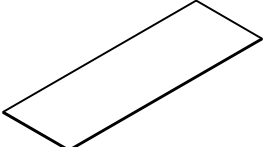
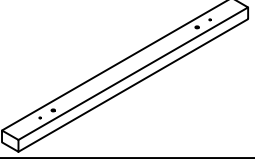
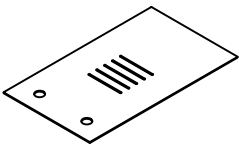
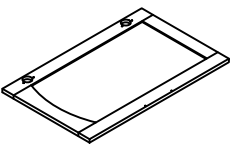
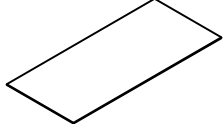
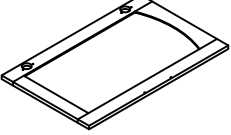
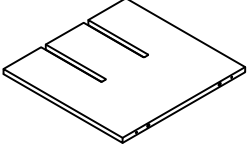
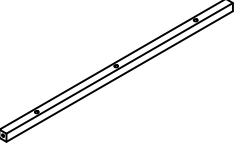
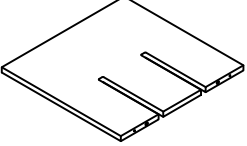
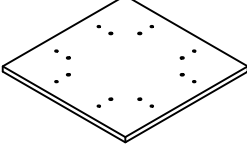
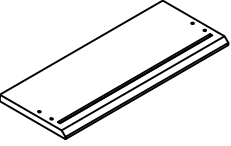
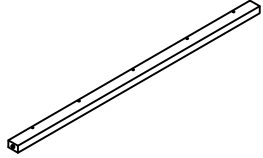
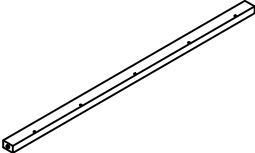



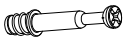









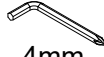

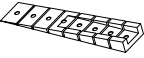
Parts List

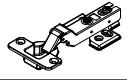
ITEM	PART	QTY	ITEM	PART	QTY
①		1PC	⑫		2PSC
②		1PC	⑬		2PSC
③		1PC	⑭		3PSC
④		1PC	⑮		3PSC
⑤		1PC	⑯		3PSC
⑥		1PC	⑰		2PSC
⑦		1PC	⑱		1PC
⑧		1PC	⑲		2PSC
⑨		1PC	⑳		2PSC
⑩		2PSC	㉑		2PSC
⑪		1PC	㉒		2PSC

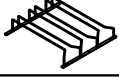
Parts List

ITEM	PART	QTY	ITEM	PART	QTY
23		2PSC	34		1PC
24		1PC	35		1PC
25		1PC	36		4PSC
26		1PC	37		1PC
27		1PC	38		1PC
28		2PSC	39		1PC
29		2PSC			
30		1PC			
31		2PSC			
32		1PC			
33		1PC			

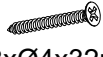
Hareware List

ITEM	PART	QTY	ITEM	PART	QTY
A	 Ø6x35mm	85+5 PCS	N		24+2 PCS
B	 Ø15x10mm	97+5 PCS	N	 Ø6xØ3x16mm	24+2 PCS
C	 Ø6x30mm	90+5 PCS	O		4 PCS
D	 Ø5x38mm	16+1 PCS	P	 Ø20mm	55+5 PCS
E	 450mm	4 PCS	Q		6+1 PCS
F	 Ø6xØ3x12mm	62+5 PCS	R	 4mm	1 PC
G		2 PCS	S		6 PCS
H	 Ø7xØ3.5x12mm	24+2 PCS	T	 Ø8xØ4x16mm	6+1 PCS
I		4 PCS	U	 M6x35mm	5+1 PCS
J		1 PC	V		1 PC
K		12+1 PCS	W		8 PCS
L	 Ø8xØ4x32mm	24+2 PCS			1 PC
M		2+1 PCS			

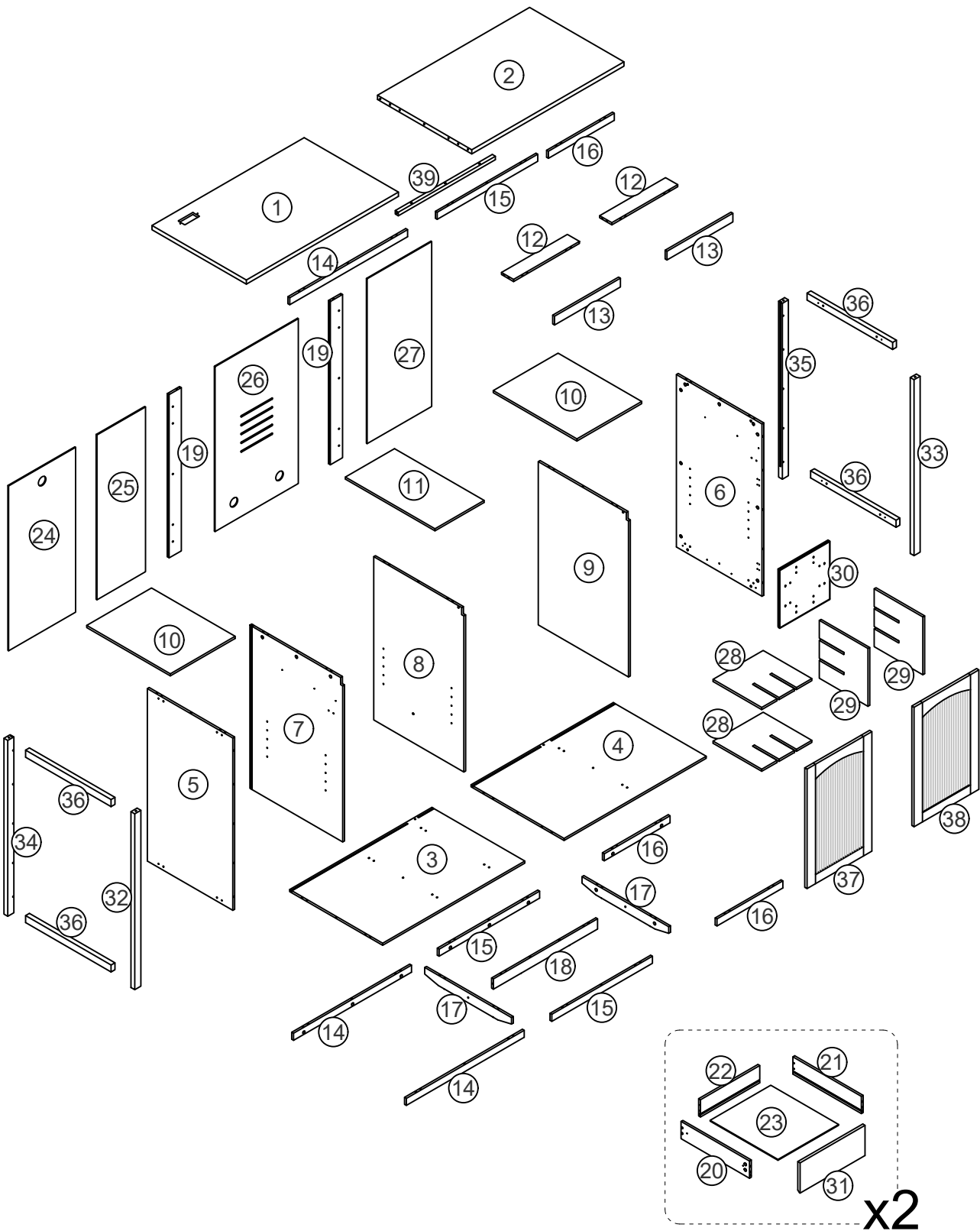

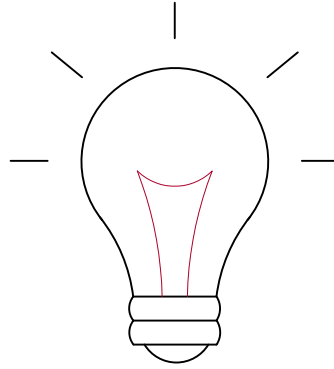

friendly reminder

To avoid errors and confusion during the installation of accessories, use the type and quantity of hardware accessories according to the installation procedure described in the instructions. First, unroll the accessories bag and lay out the hardware accessories, cut holes in the side, and take out the hardware accessories

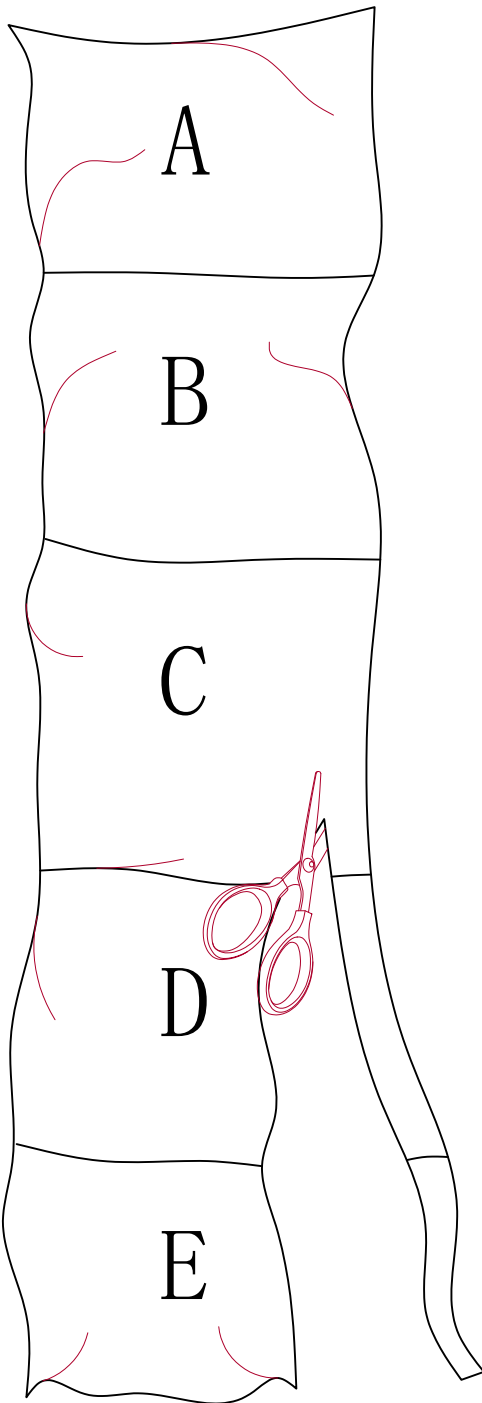

01

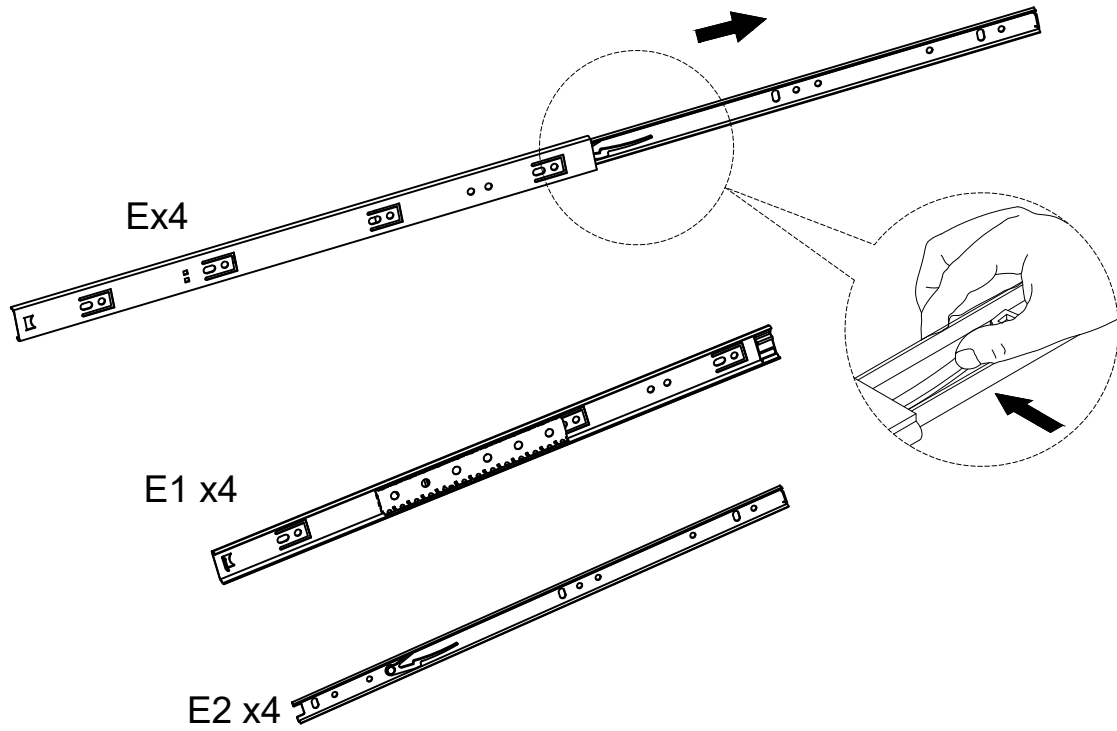

Extend slides E x4, then push the release lever upward to detach the outer rail E1 x4 and the inner rail E2 x4 as shown.

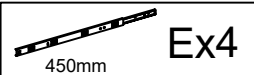

02

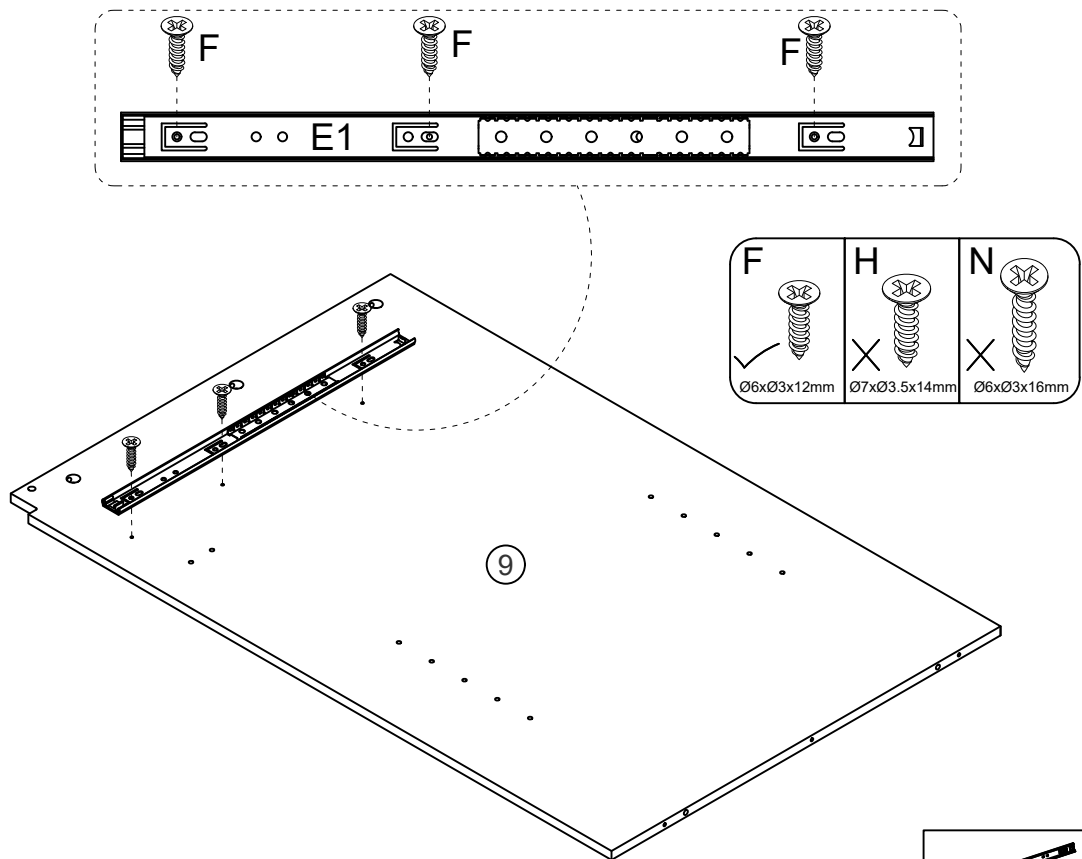

Install outer rail E1 on Part #9 with Screws F x3 as shown.



03

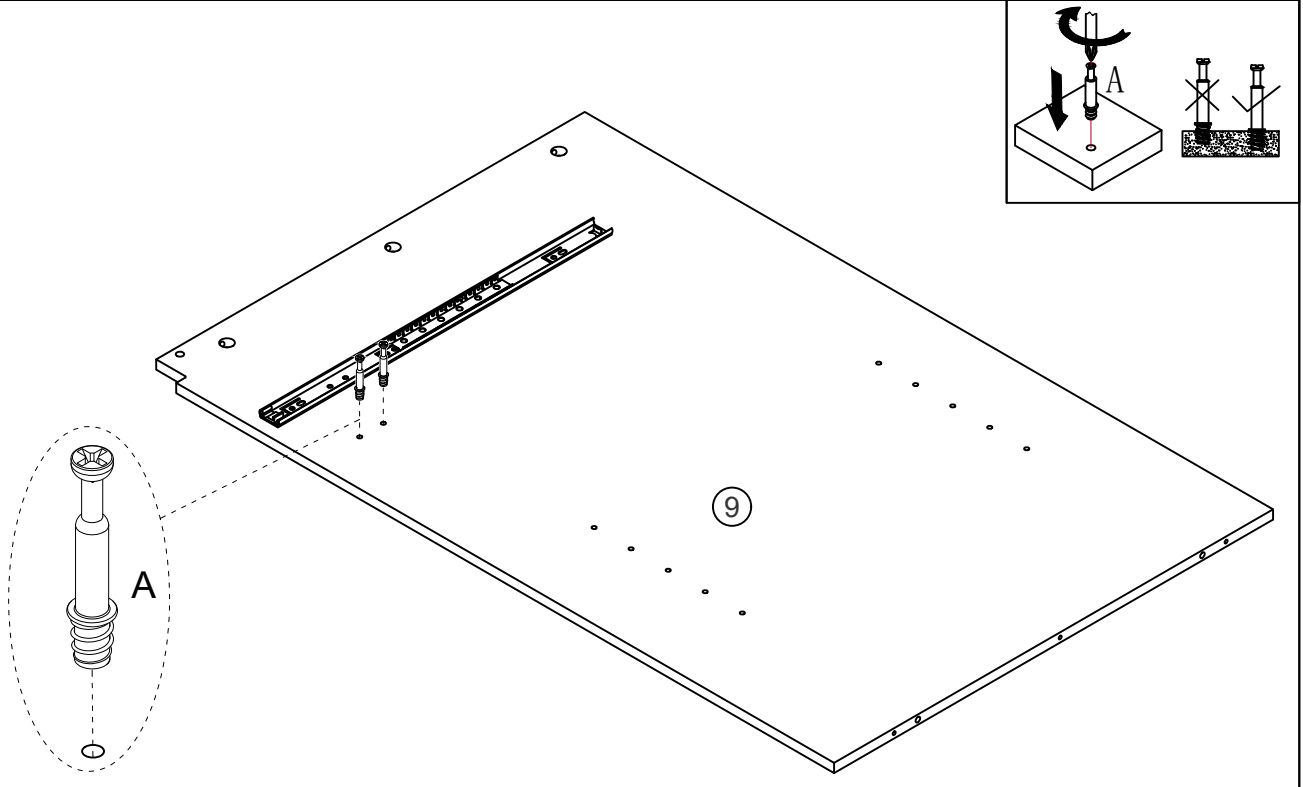

Install Cam Bolt A x2 on Part #9 as shown.

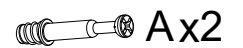

04

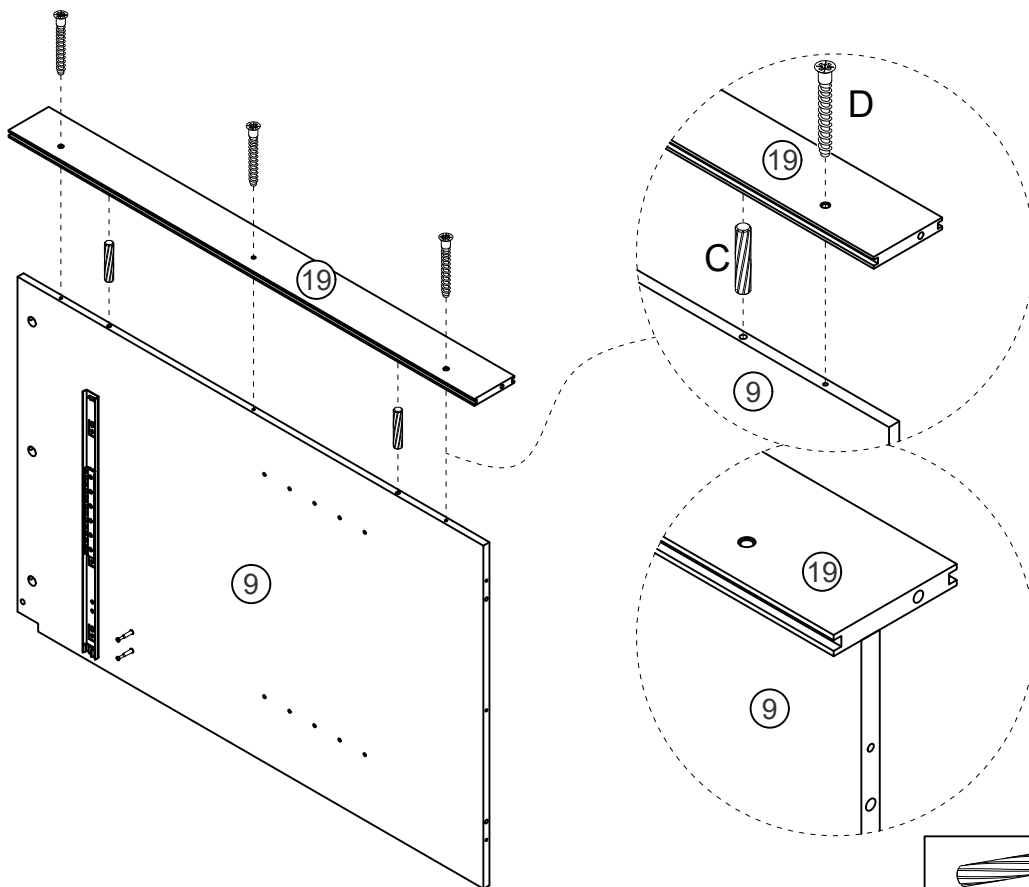

Attach Part #19 to Part #9 with Dowels C x2 and Screws D x3 as shown.

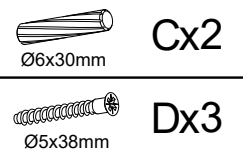

05

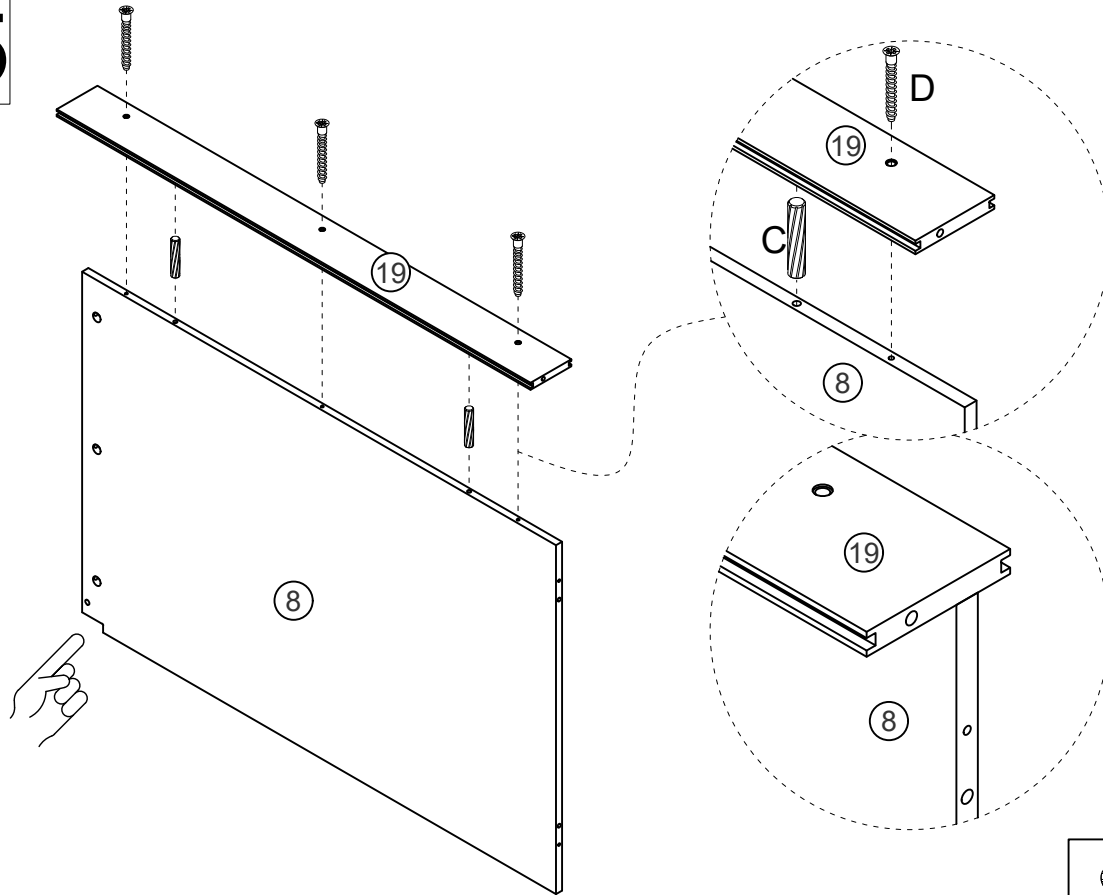

Attach Part #19 to Part #8 with Dowels C x2 and Screws D x3 as shown.

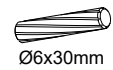

Cx2

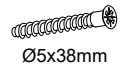

Dx3

06

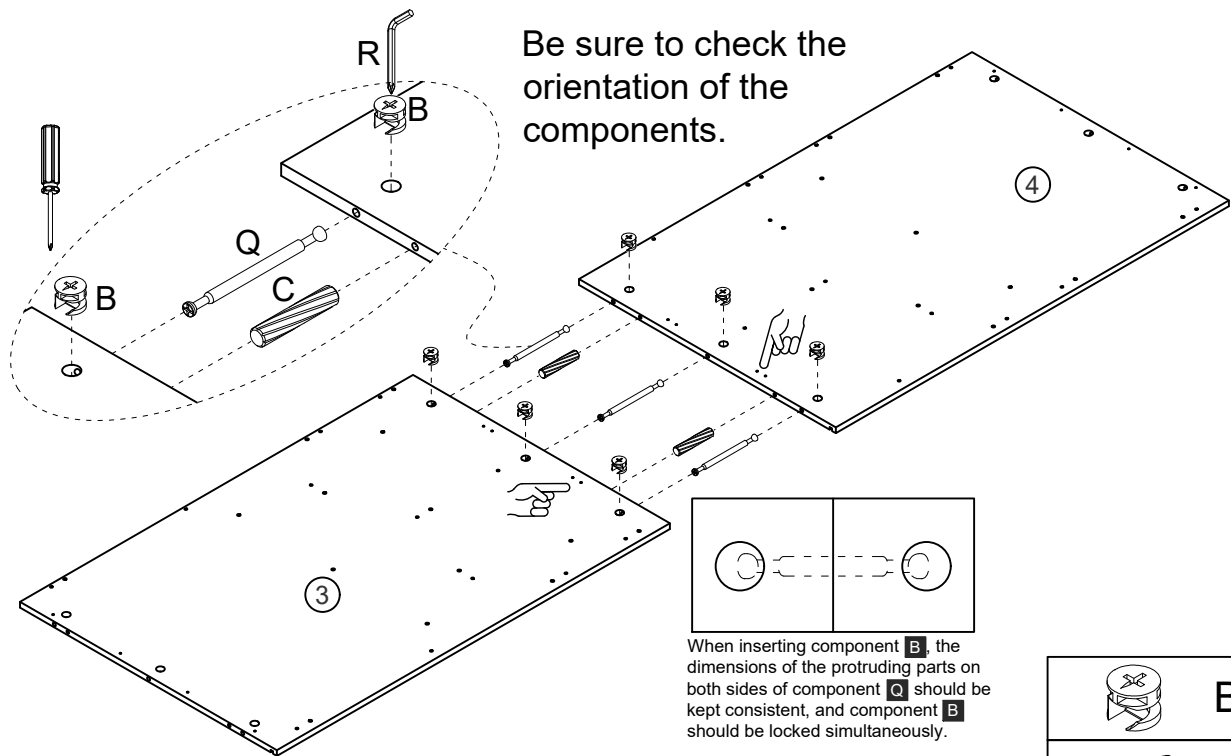

Be sure to check the orientation of the components.

When inserting component **B**, the dimensions of the protruding parts on both sides of component **Q** should be kept consistent, and component **B** should be locked simultaneously.

Connect Part #3 to Part #4 with Q x3, Dowels C x2, and Nuts B x6 as shown.

Then tighten the Nuts B on both sides of each Q simultaneously using a screwdriver and tool R as shown.



Bx6

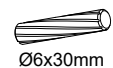

Cx2



Qx3



Rx1

07

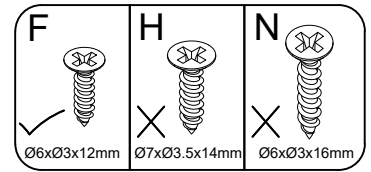
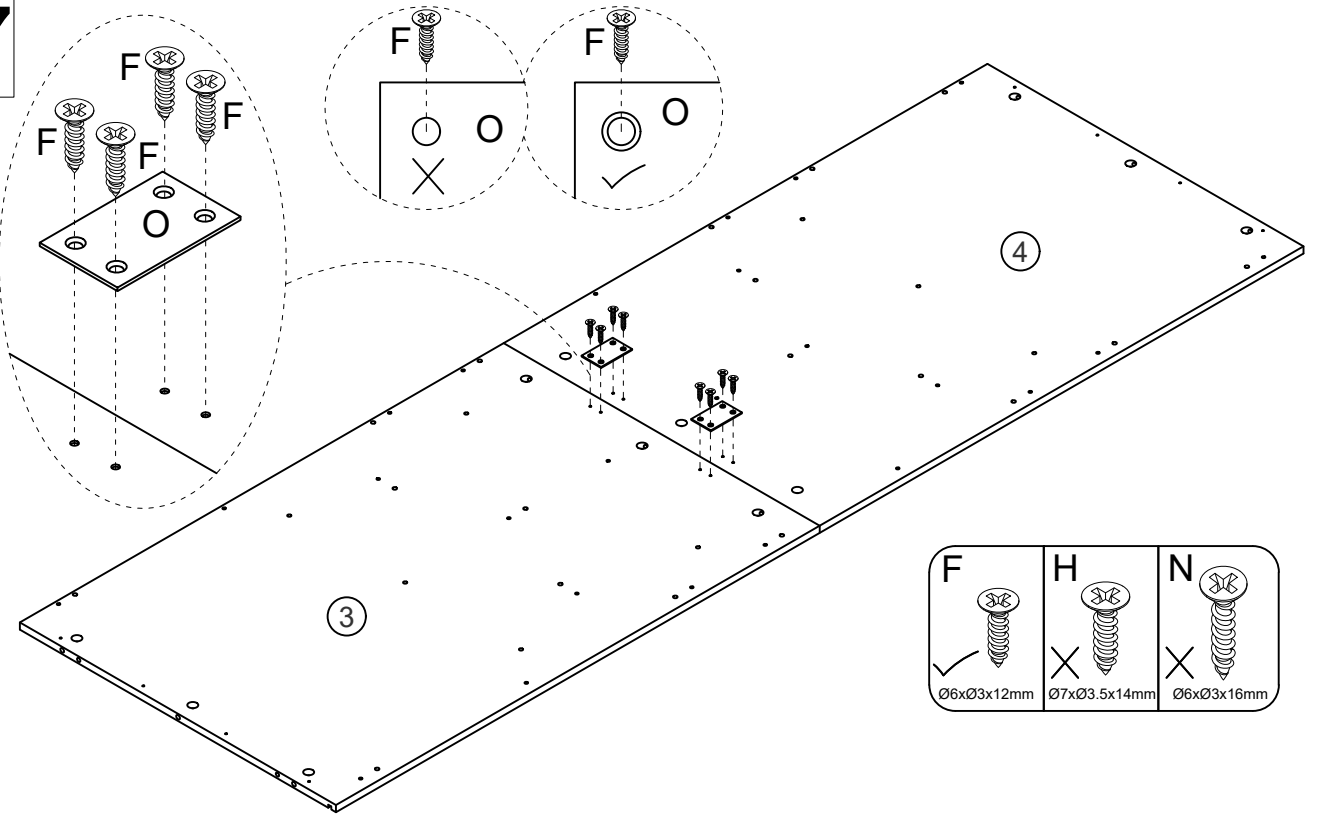

Install O x2 on Part #3 with Screws F x8 as shown.



08

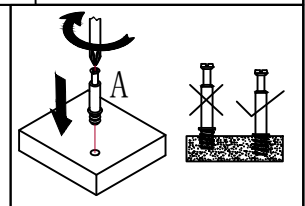
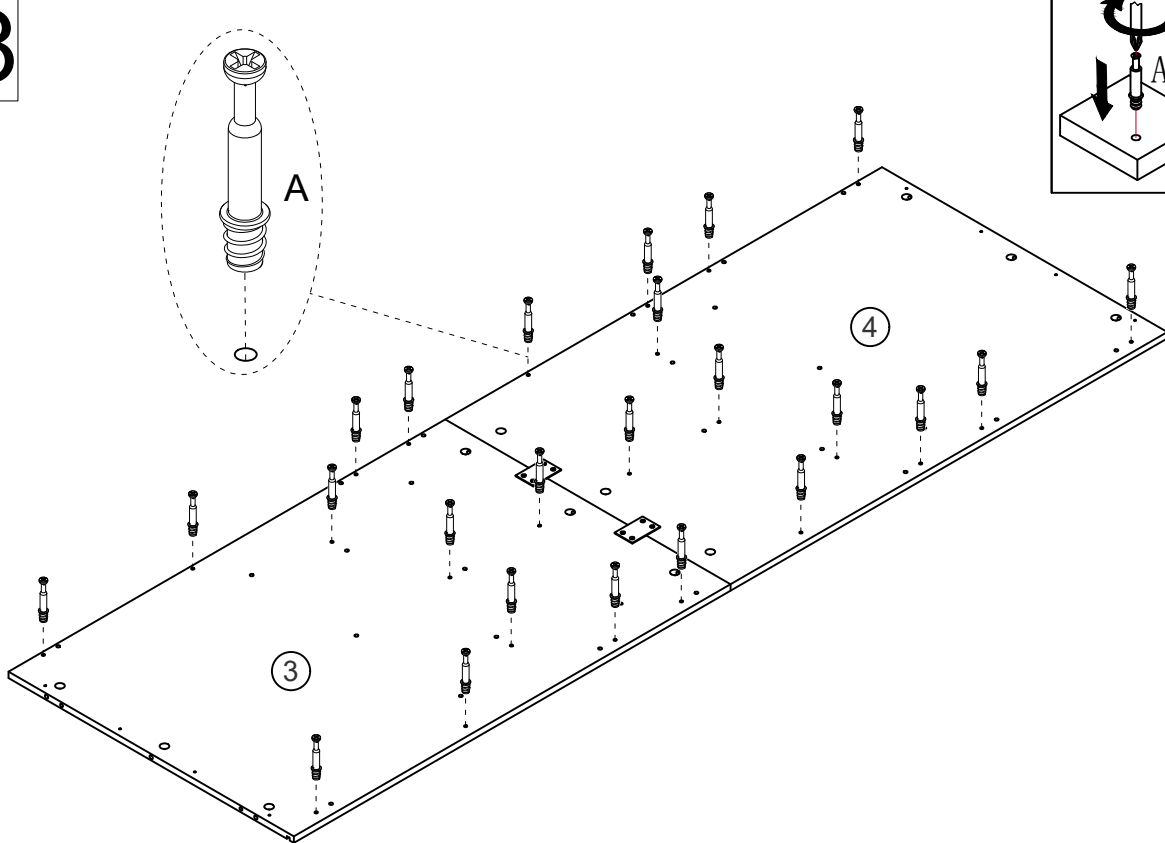

Install Cam Bolt A x24 on Part #3 as shown.



09

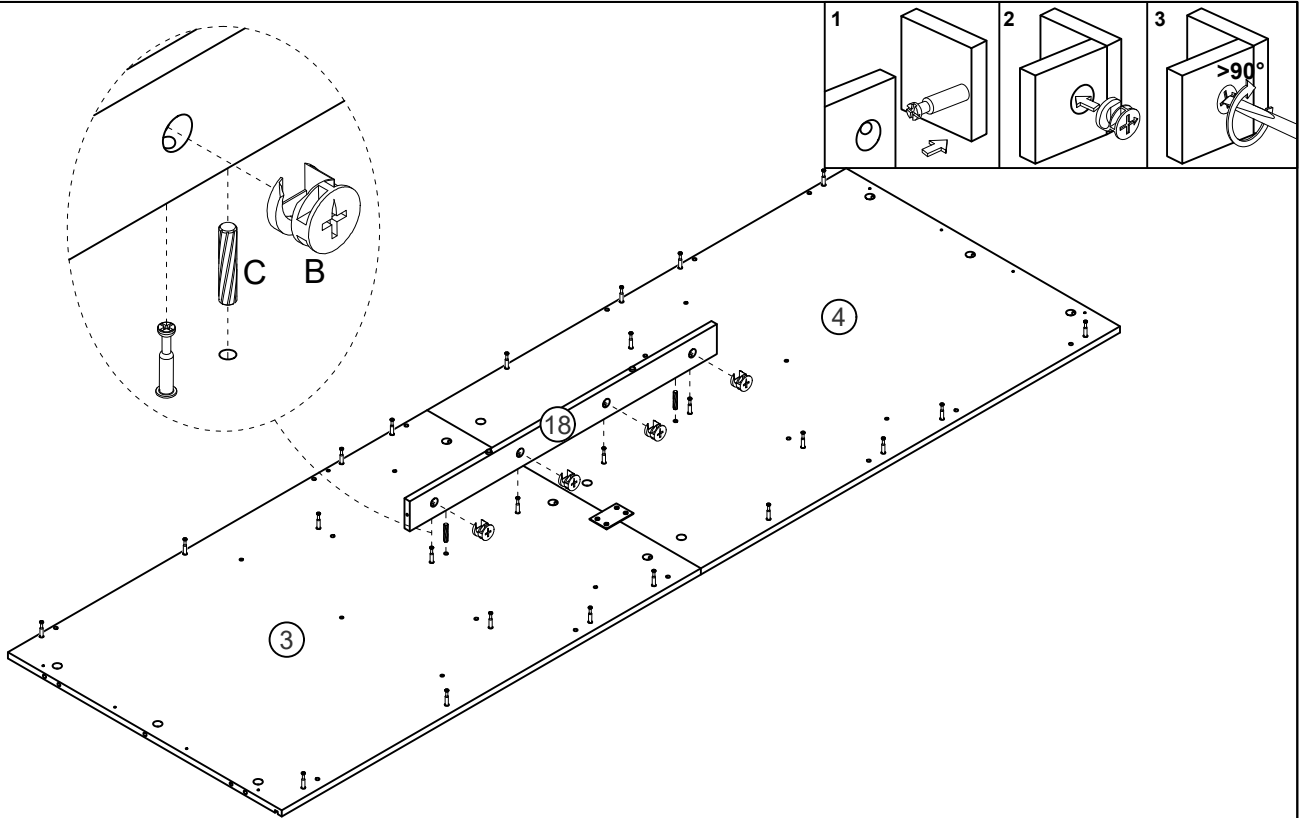

Attach Part #18 to Part #3 with Dowels C x2 and Nuts B x4 as shown.
Then turn Nuts B x4 to secure position.

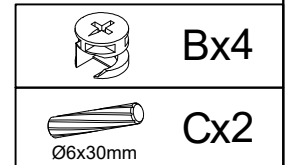

10

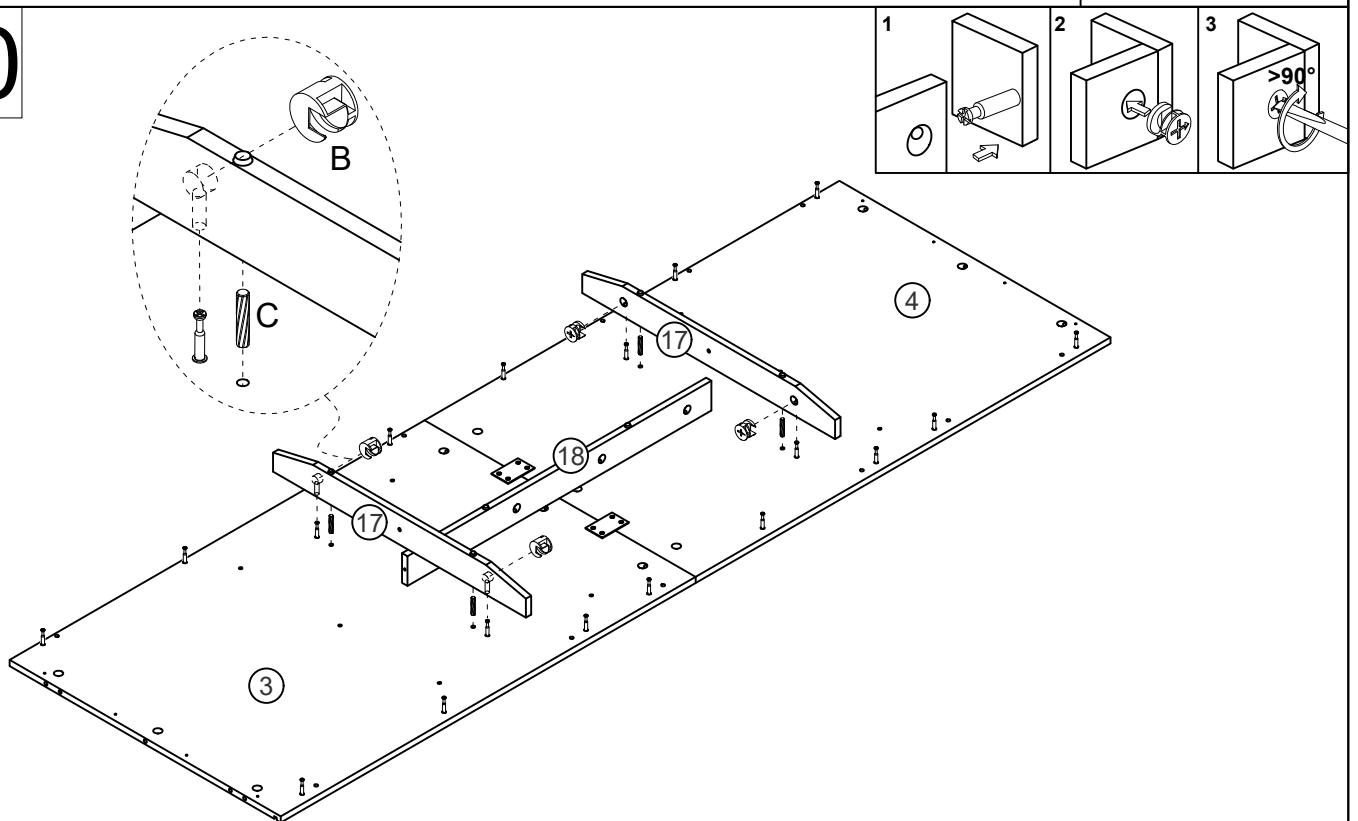

Attach Part #17 x2 to Part #3 with Dowels C x4 and Nuts B x4 as shown.
Then turn Nuts B x4 to secure position.

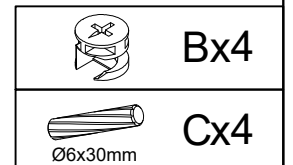

11

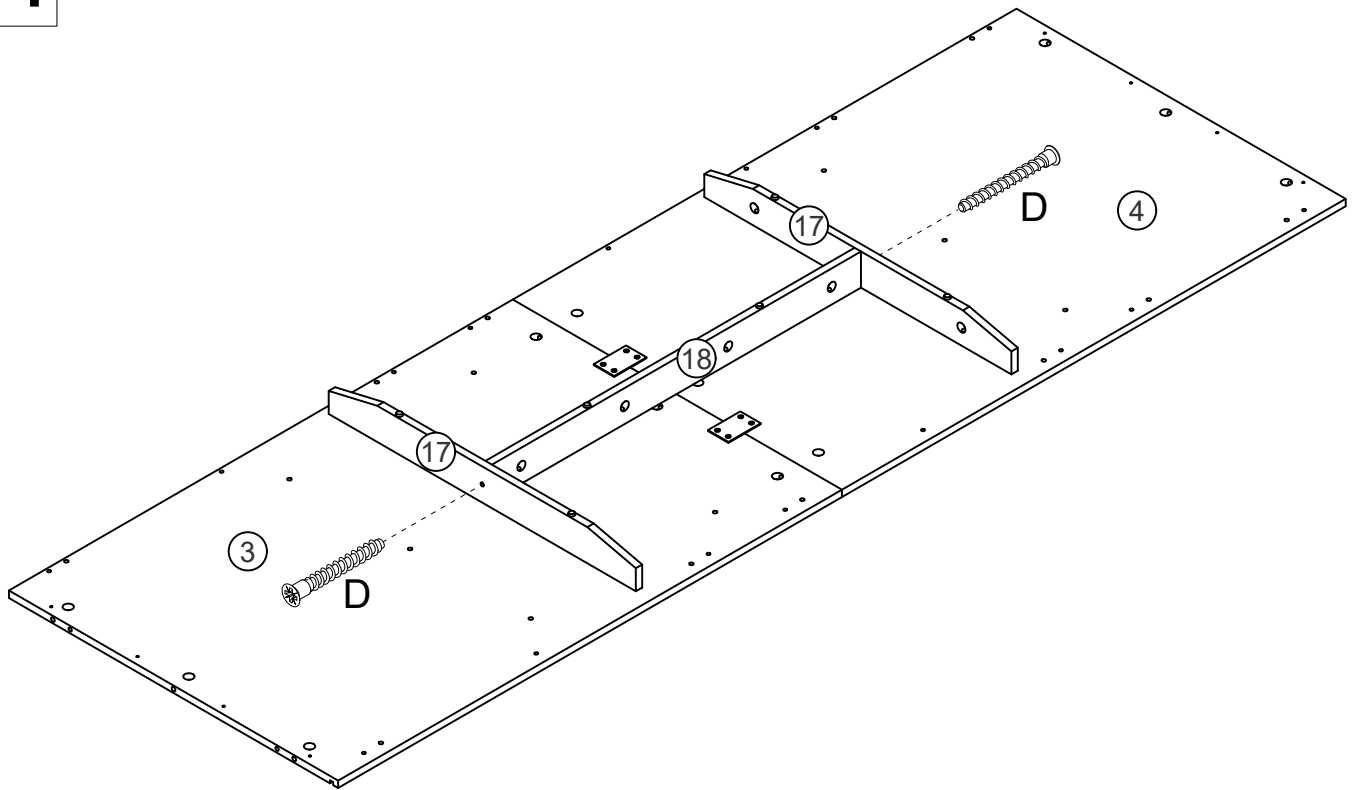

Secure Part #17 x2 to Part #18 with Screws D x2 as shown.

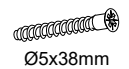

Dx2

Ø5x38mm

12

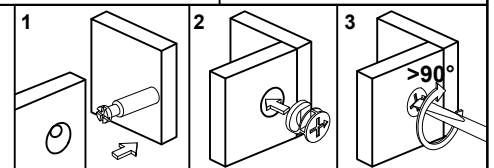
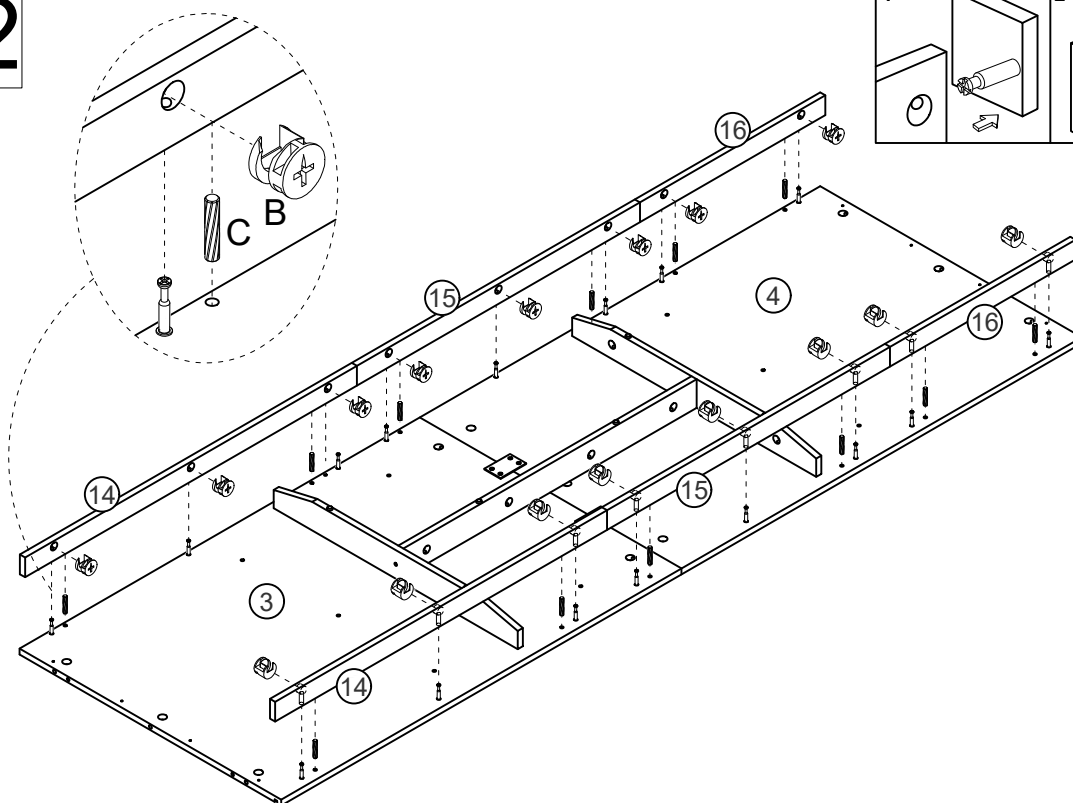

Attach Part #14 x2, Part #15 x2 and Part #16 x2 to Part #3 with Dowels C x12 and Nuts B x16 as shown. Then turn Nuts B x16 to secure position.



Bx16

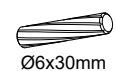

Cx12

Ø6x30mm

13

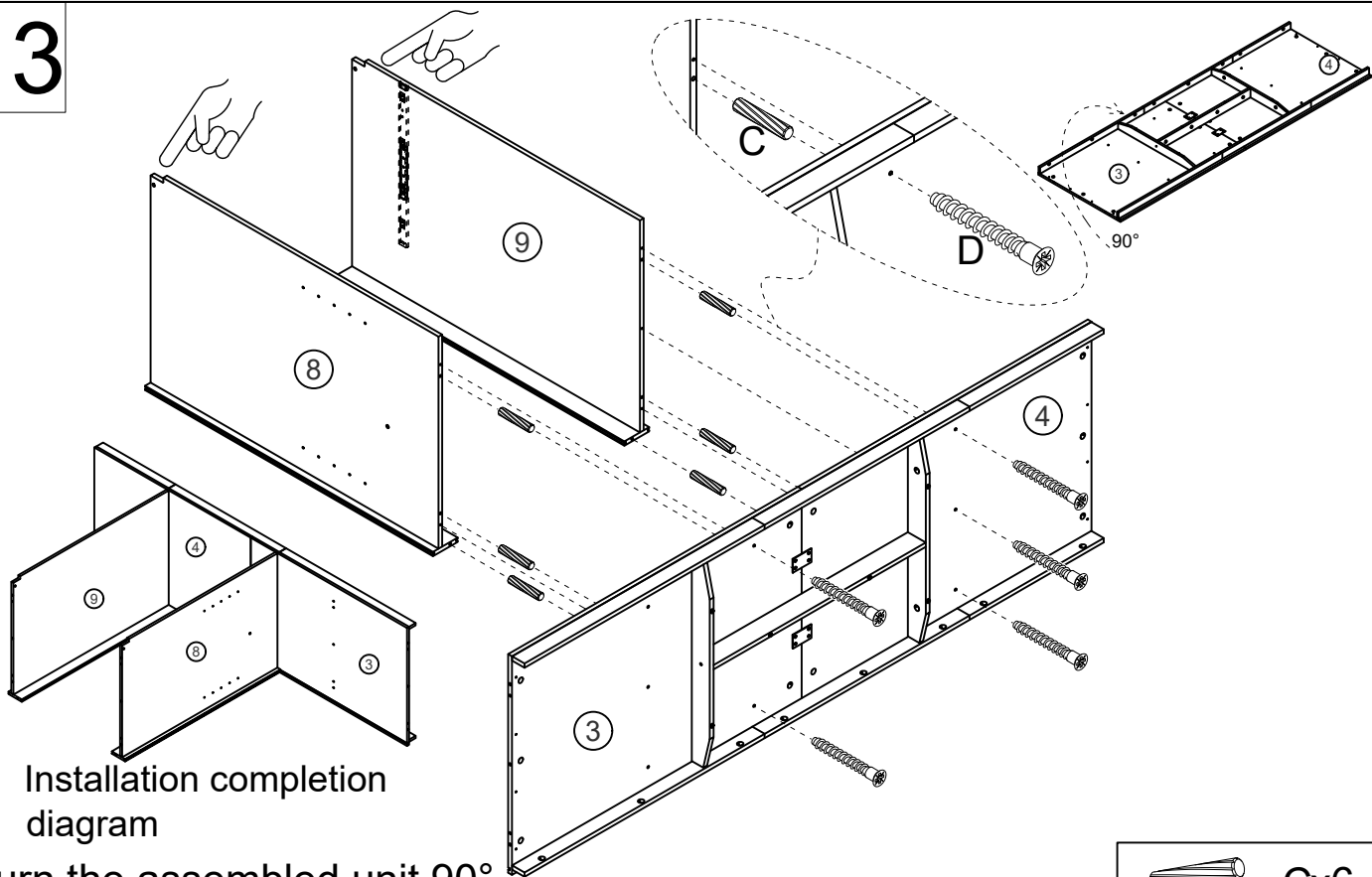

Turn the assembled unit 90°. Then attach Part #8 and Part #9 to the assembled unit with Dowels C x6 and Screws D x5 as shown.

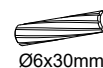

Cx6

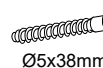

Dx5

14

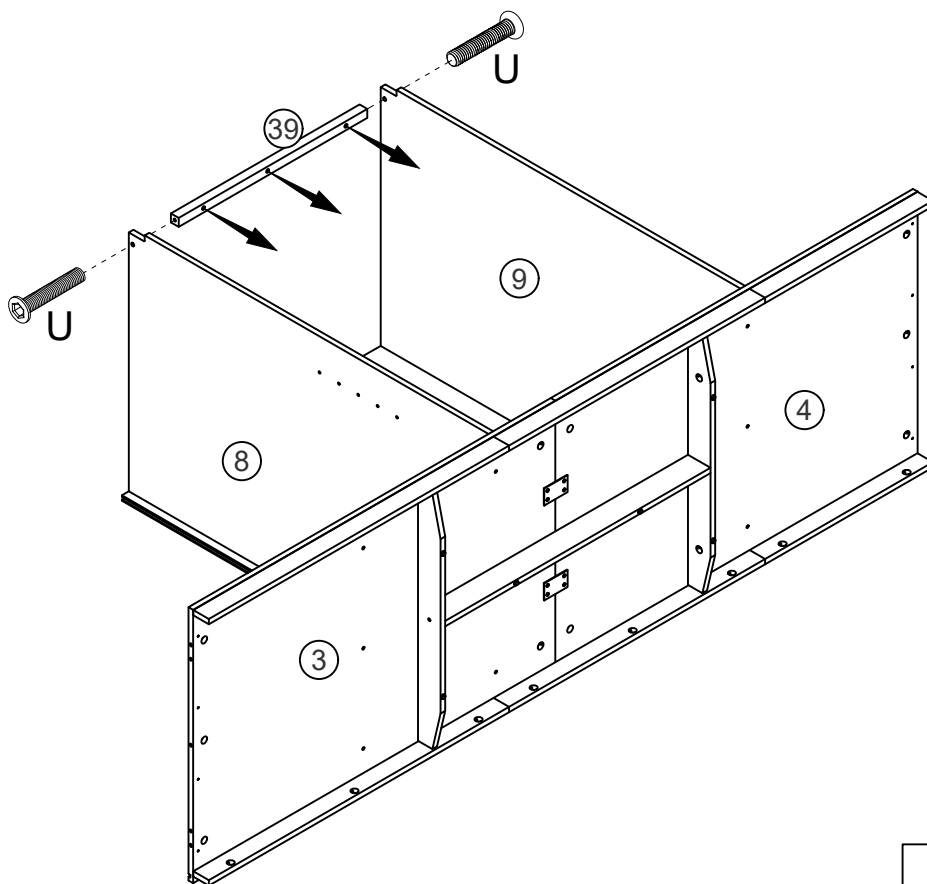

Attach Part #39 to Part #8 and Part #9 with Screws U x2 as shown.



Rx1



Ux2

15

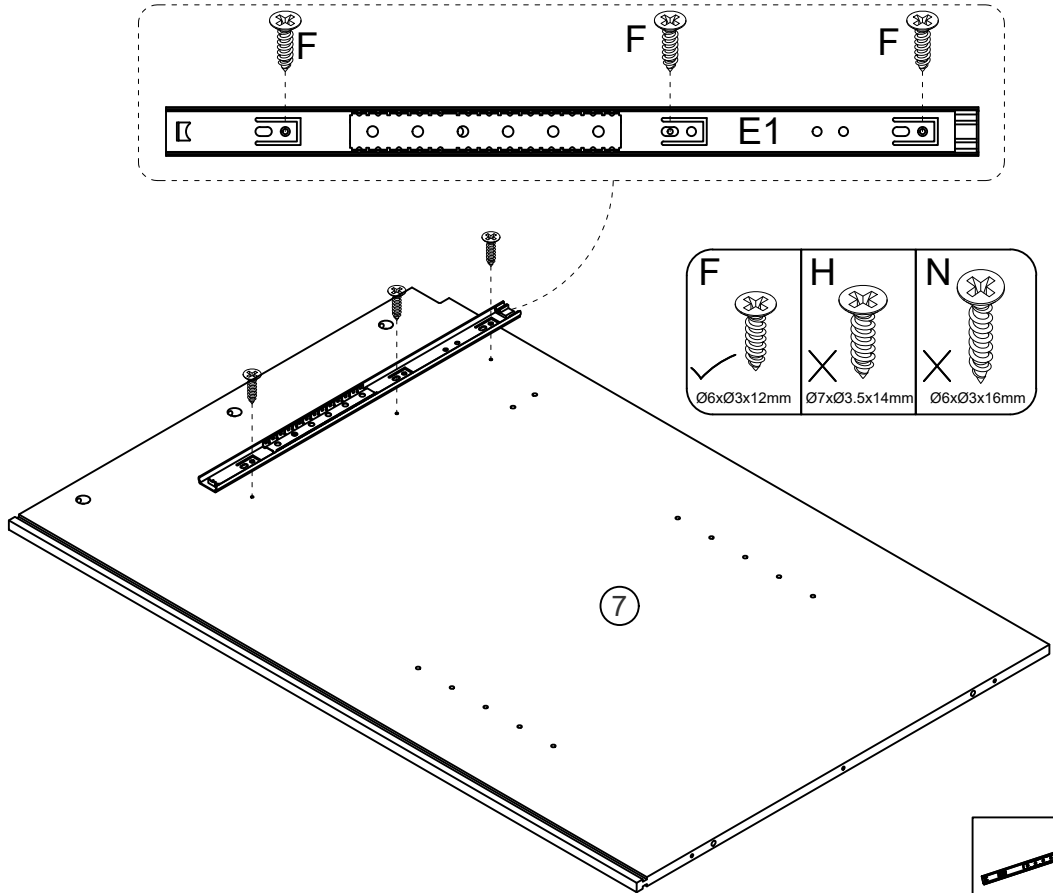

Install outer rail E1 on Part #7 with Screws F x3 as shown.

16

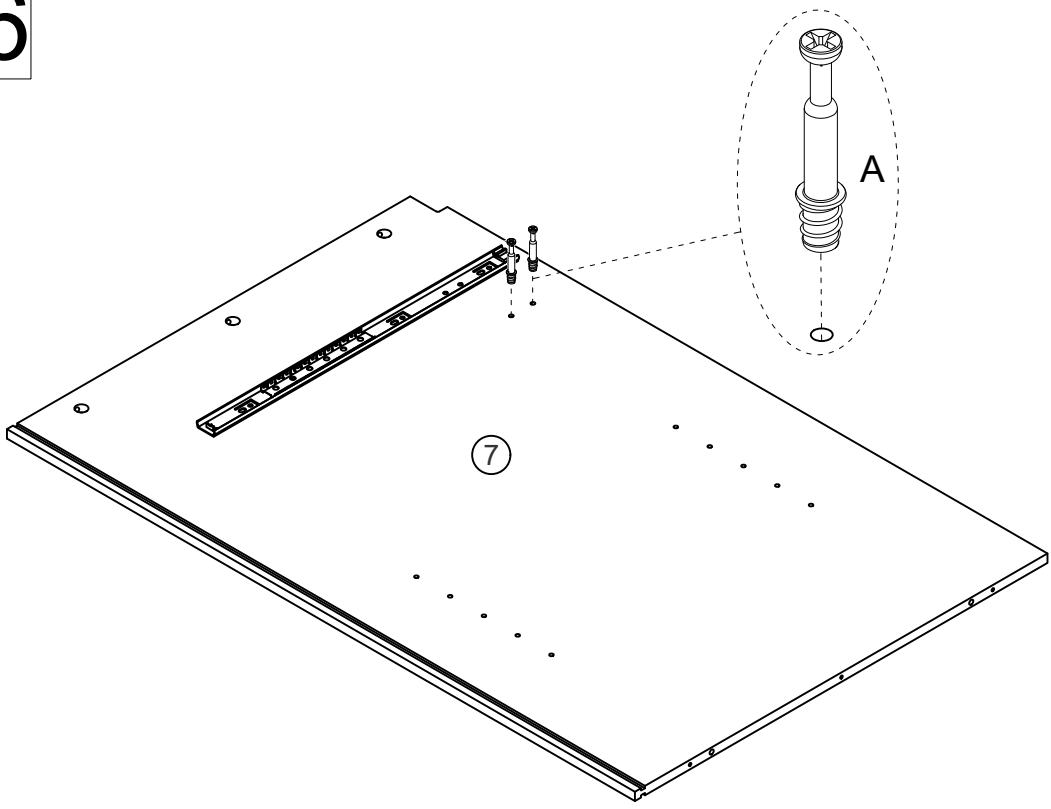

Install Cam Bolt A x2 on Part #7 as shown.

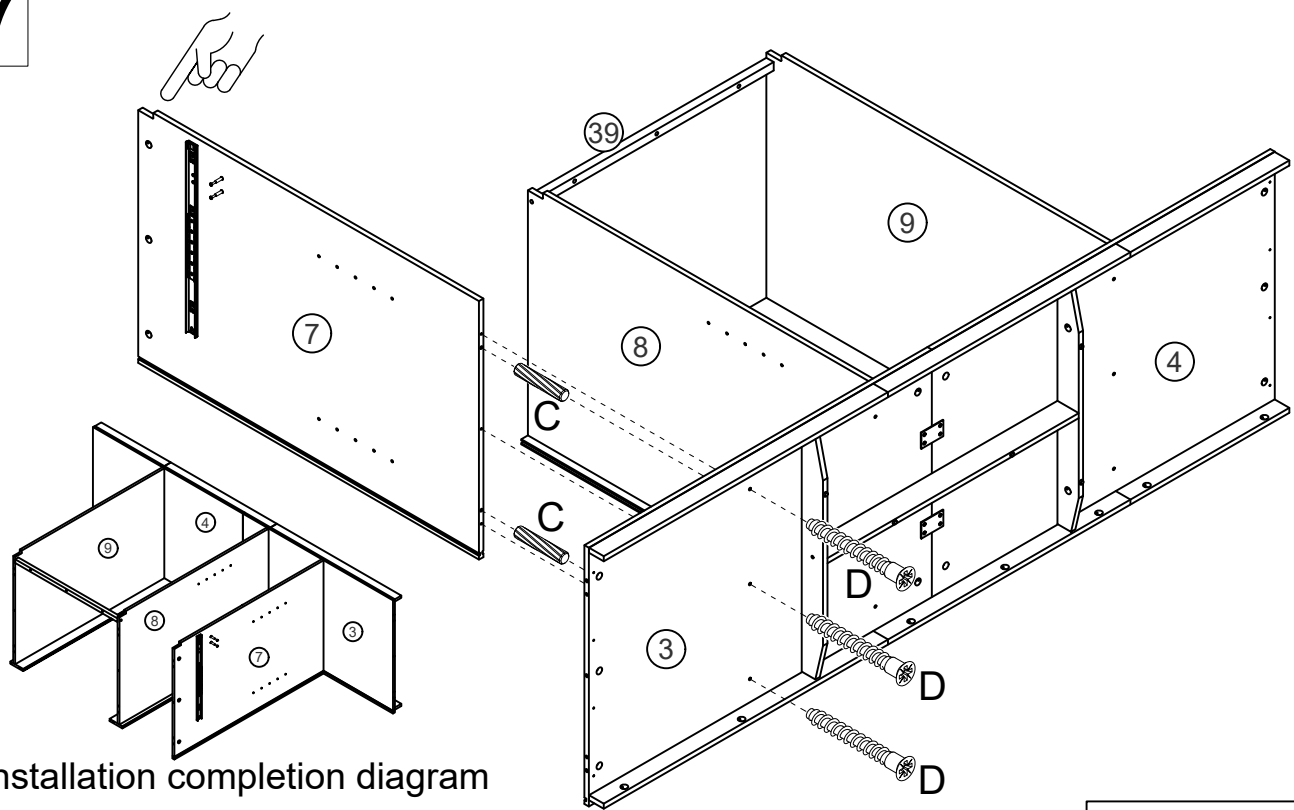

Ax2

17



Installation completion diagram



Attach Part #7 to the assembled unit with Dowels C x2 and Screws D x3 as shown.

	Cx2
<small>Ø6x30mm</small>	
	Dx3
<small>Ø5x38mm</small>	

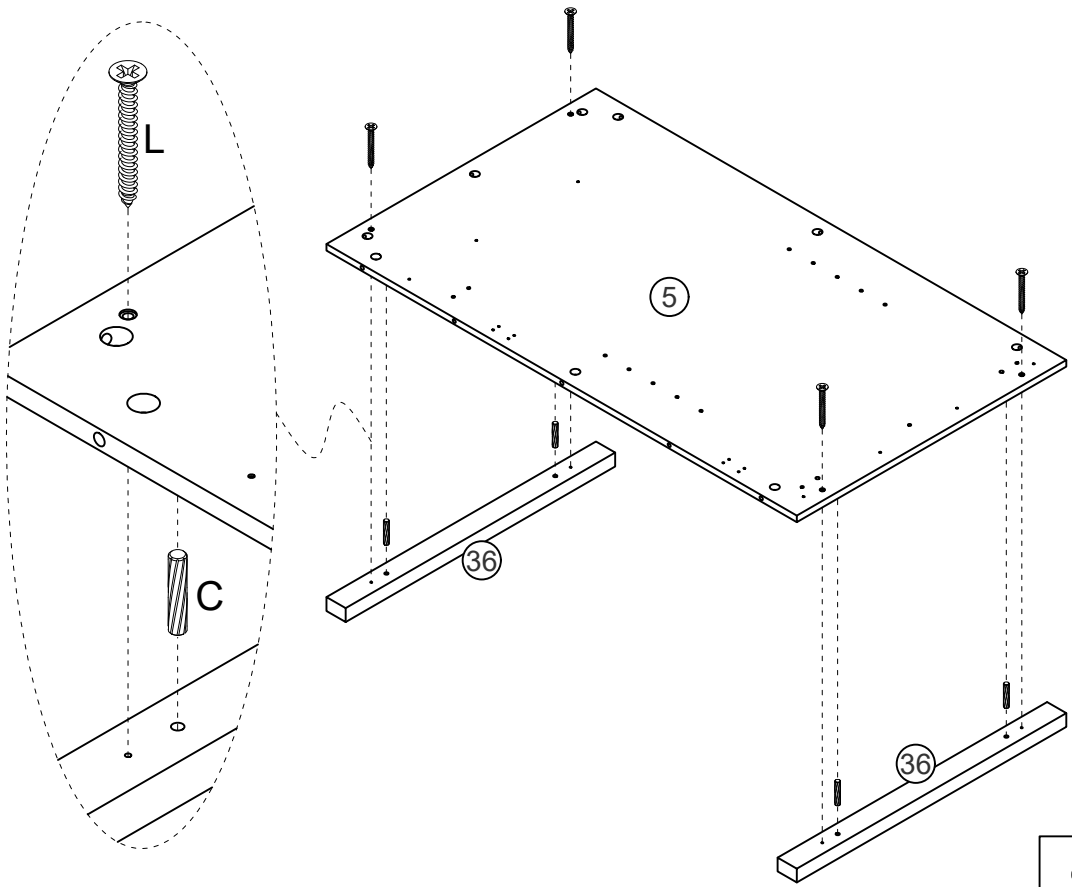
18



Attach Part #36 x2 to Part #5 with Dowels C x4 and Screws L x4 as shown.

	Cx4
<small>Ø6x30mm</small>	
	Lx4
<small>Ø8xØ4x32mm</small>	

19

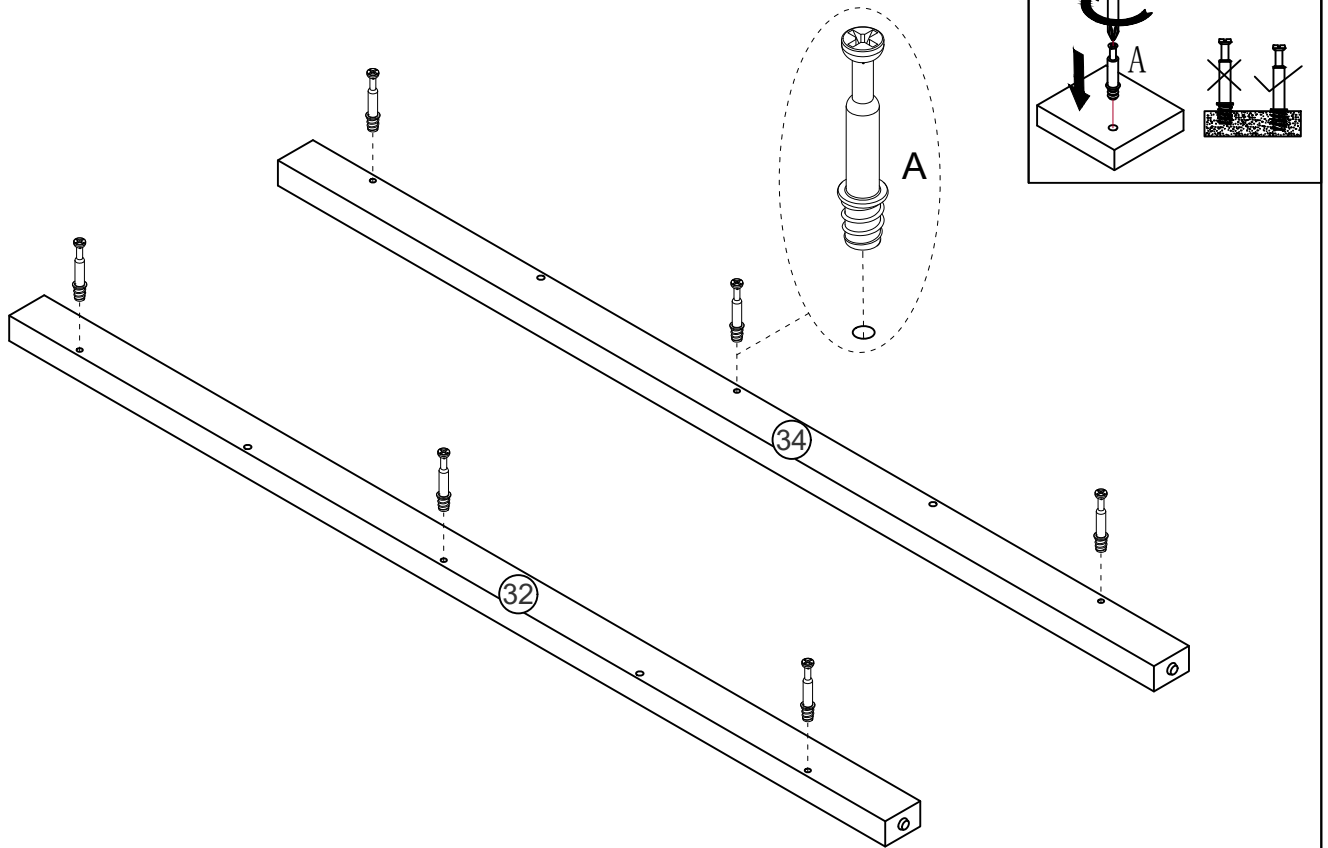

Install Cam Bolt A x6 on Part #32 and Part #34 as shown.

 A x6

20

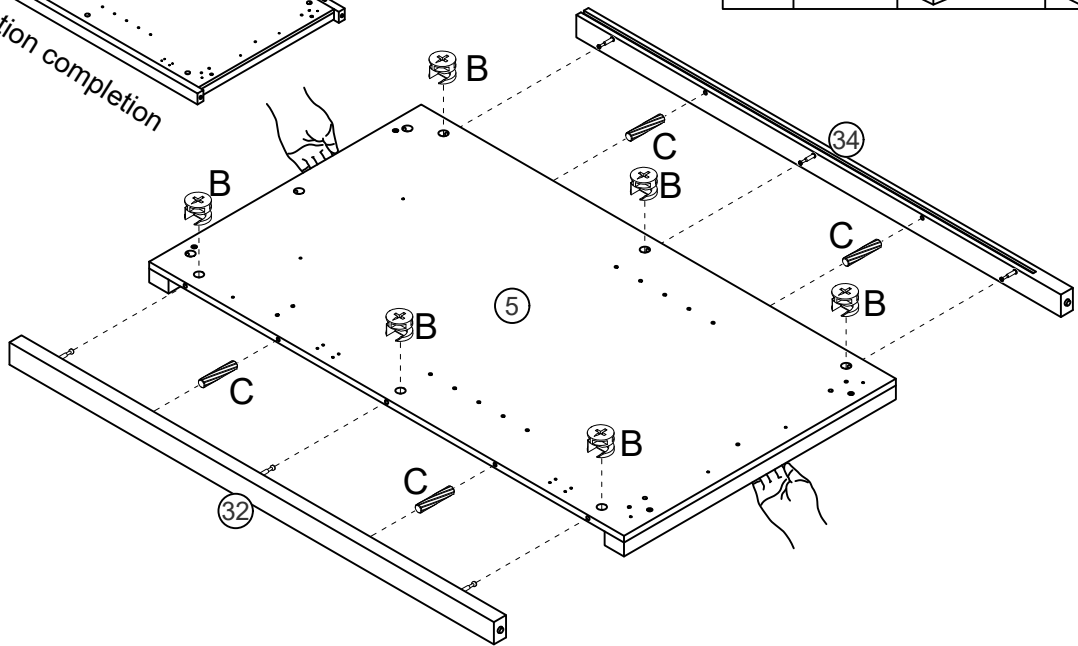
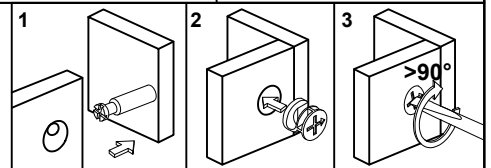
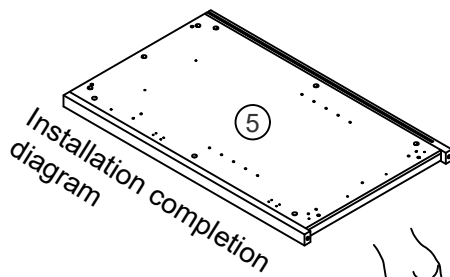

Attach Part #32 and Part #34 to Part #5 with Dowels C x4 and Nuts B x6 as shown.

Then turn Nuts B x6 to secure position.

 B x6

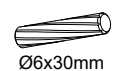
 C x4
Ø6x30mm

21

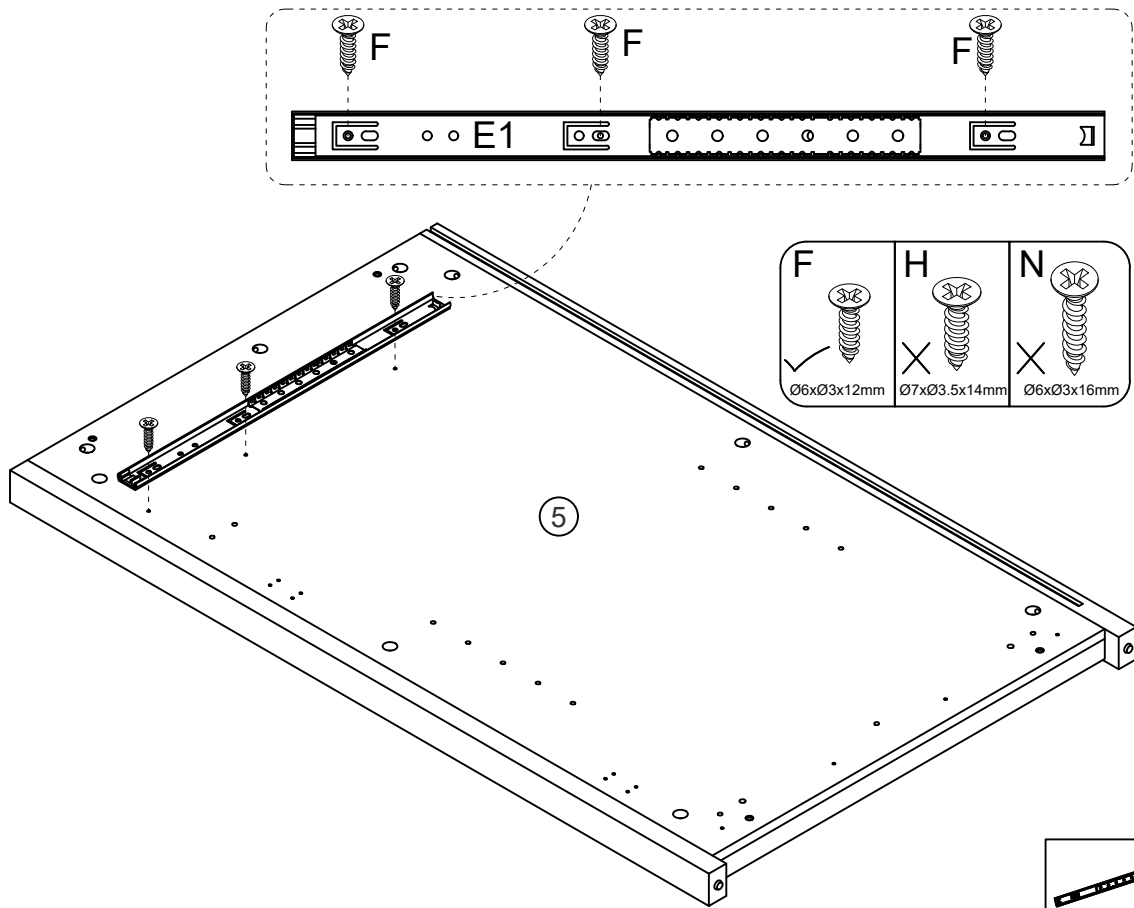

Install outer rail E1 on Part #5 with Screws F x3 as shown.

22

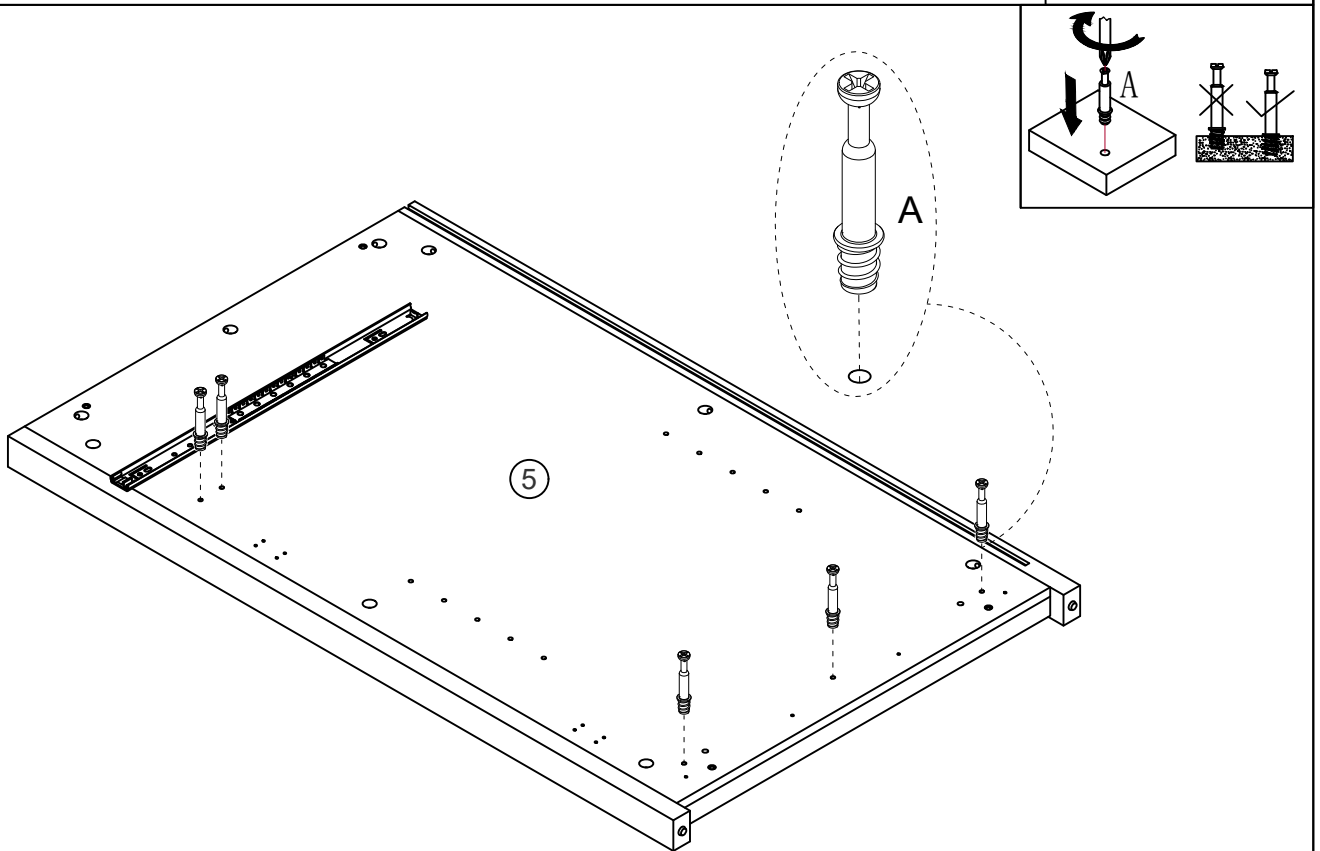

Install Cam Bolt A x5 on Part #5 as shown.

23

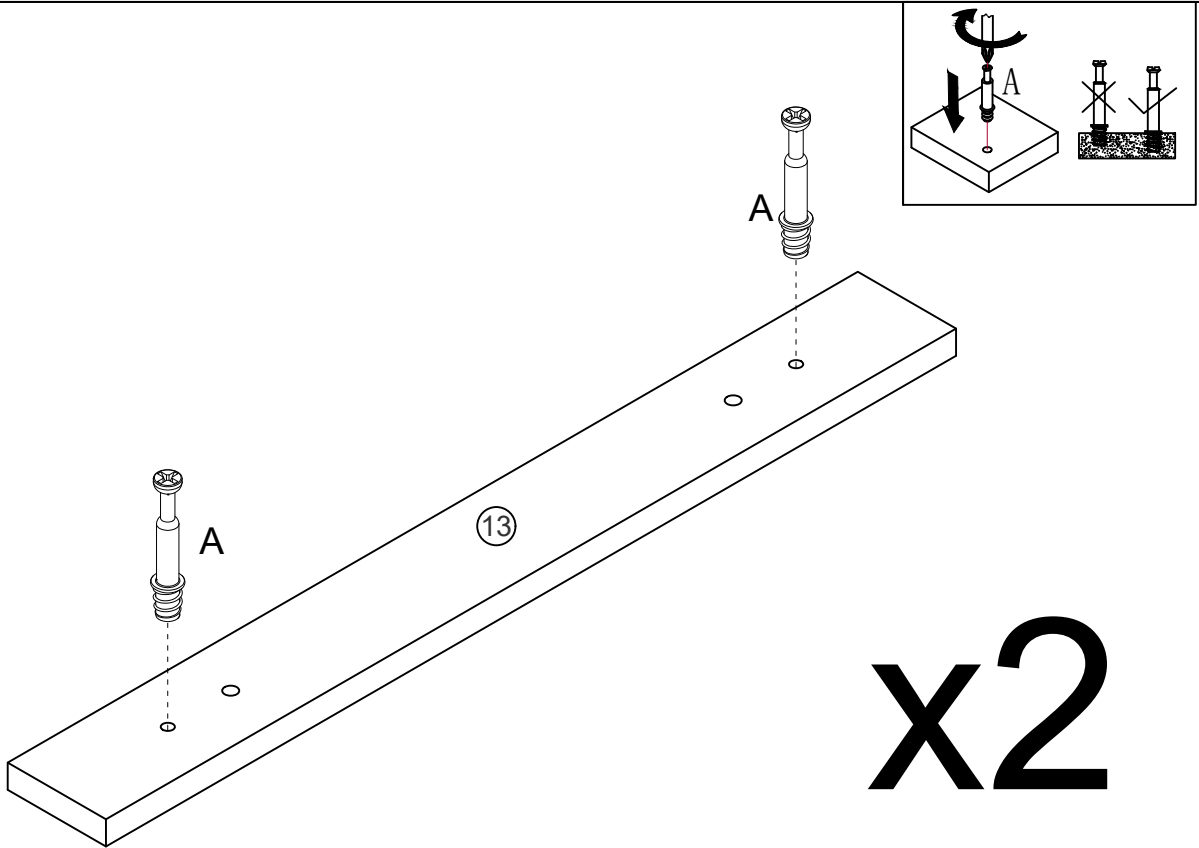

x2

Install Cam Bolt A x4 on Part #13 x2 as shown.

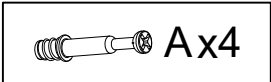

24

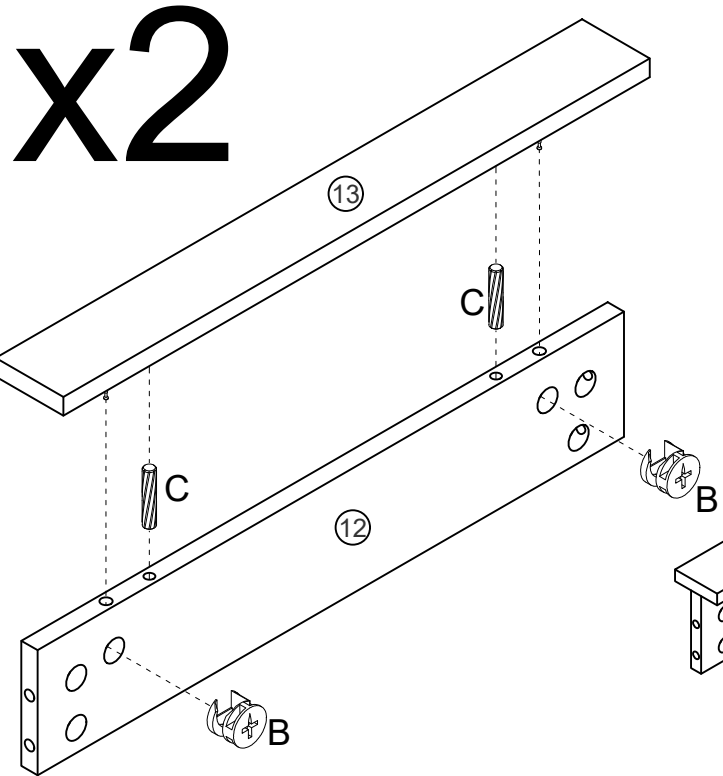

x2

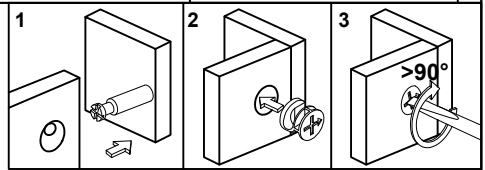

Installation completion diagram

Attach Part #13 x2 to Part #12 x2 with Dowels C x4 and Nuts B x4 as shown. Then turn Nuts B x4 to secure position.

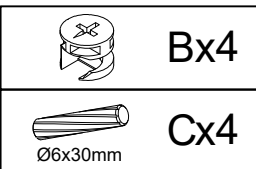

25

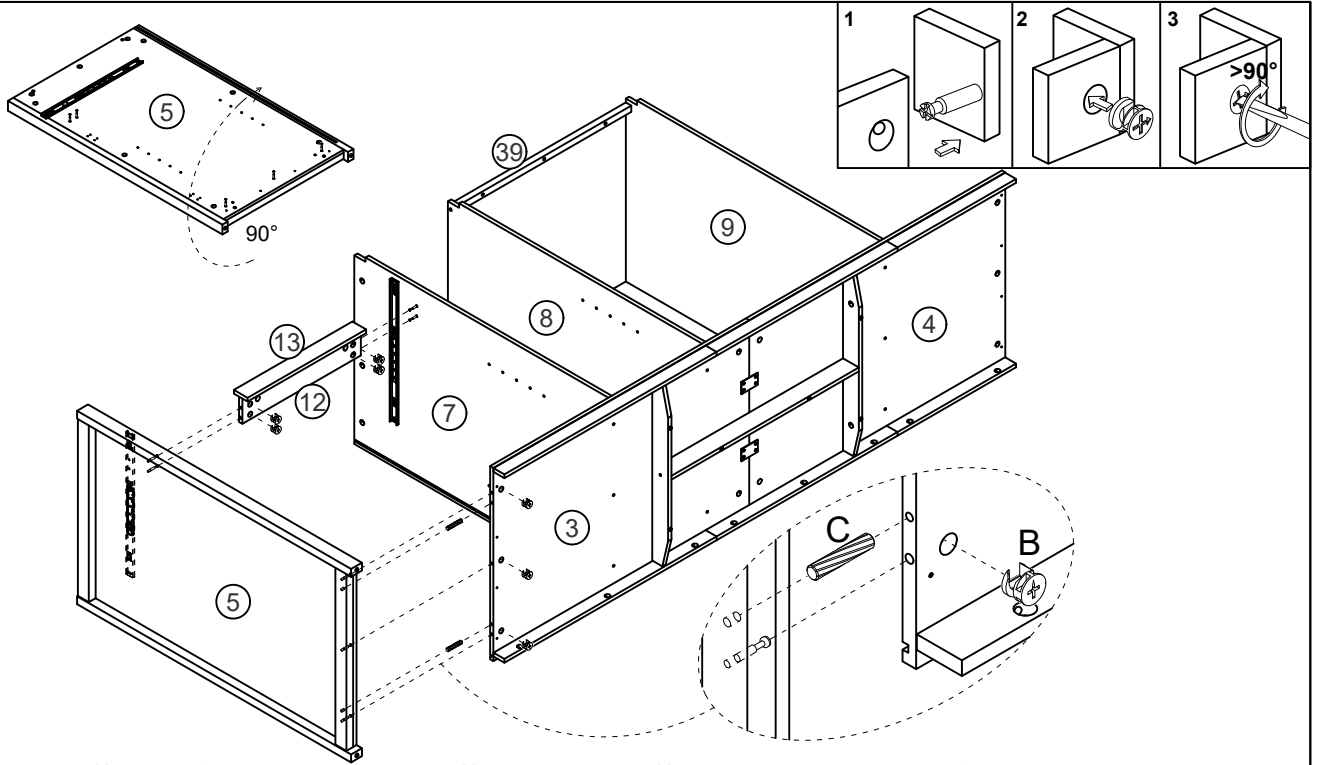

Turn Part #5 90°. Attach Part #5 to Part #3 with Dowels C x2 and Nuts B x3 as shown.

Then attach Part #5 and Part #7 to the assembled unit (Part #12) with Nuts B x4 as shown.

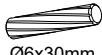

Turn Nuts B x7 to secure position.

	Bx7
	Cx2 Ø6x30mm

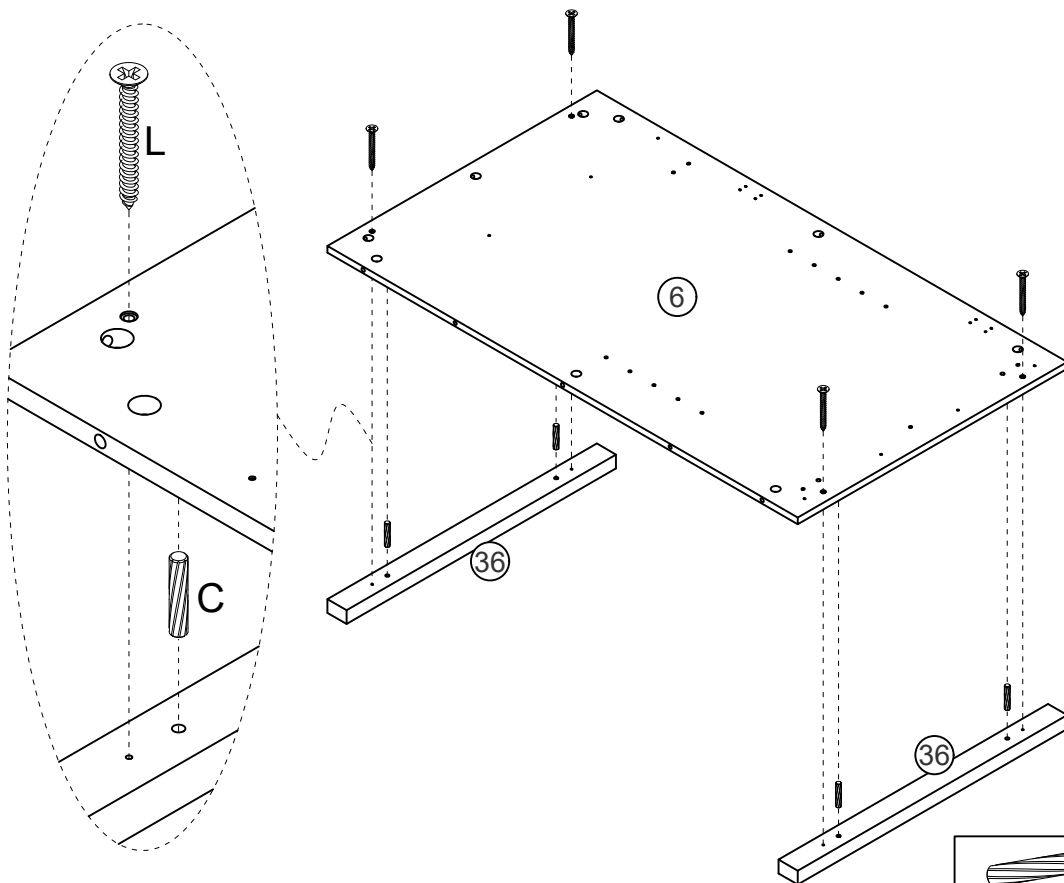
26

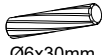

Attach Part #36 x2 to Part #6 with Dowels C x4 and Screws L x4 as shown.

	Cx4 Ø6x30mm
	Lx4 Ø8xØ4x32mm

27

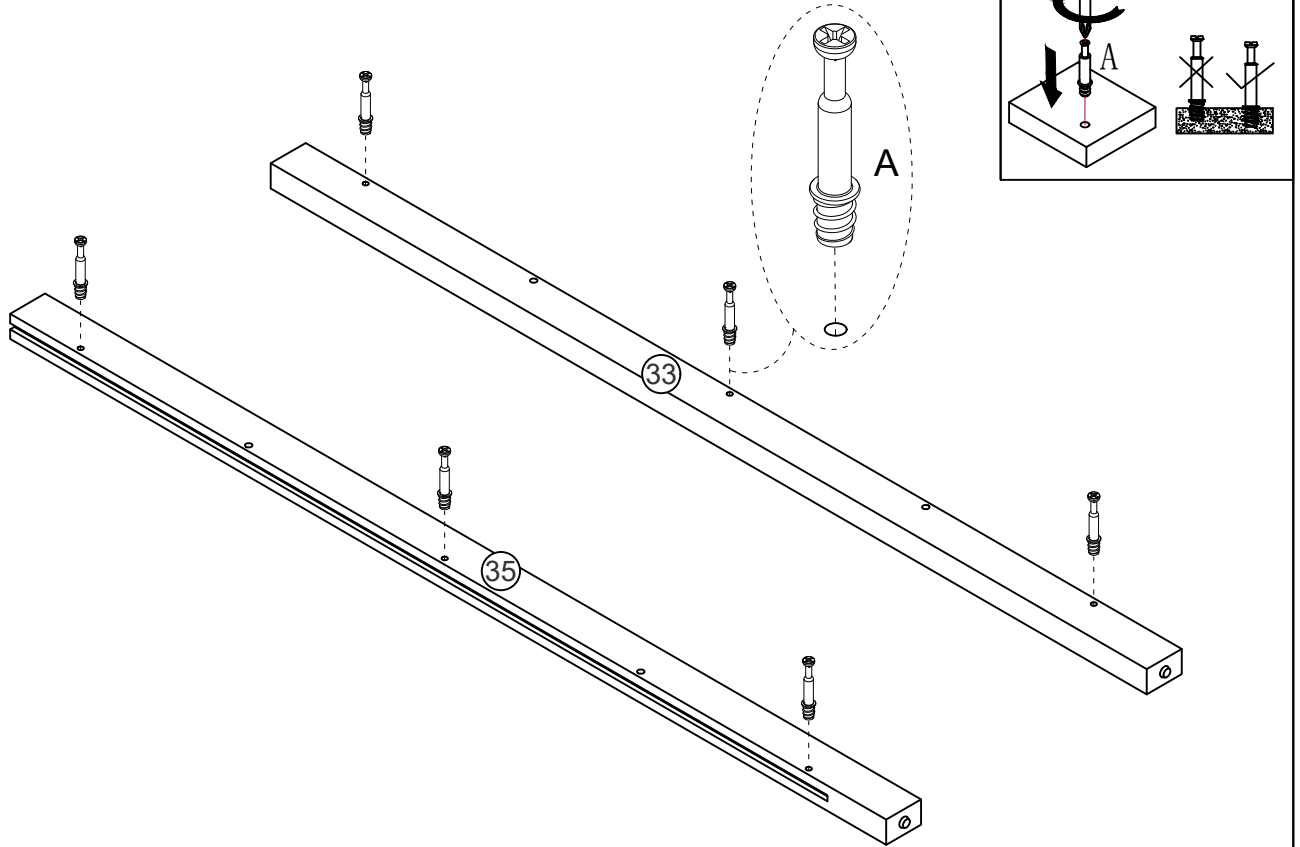

Install Cam Bolt A x6 on Part #33 and Part #35 as shown.

 A x6

28

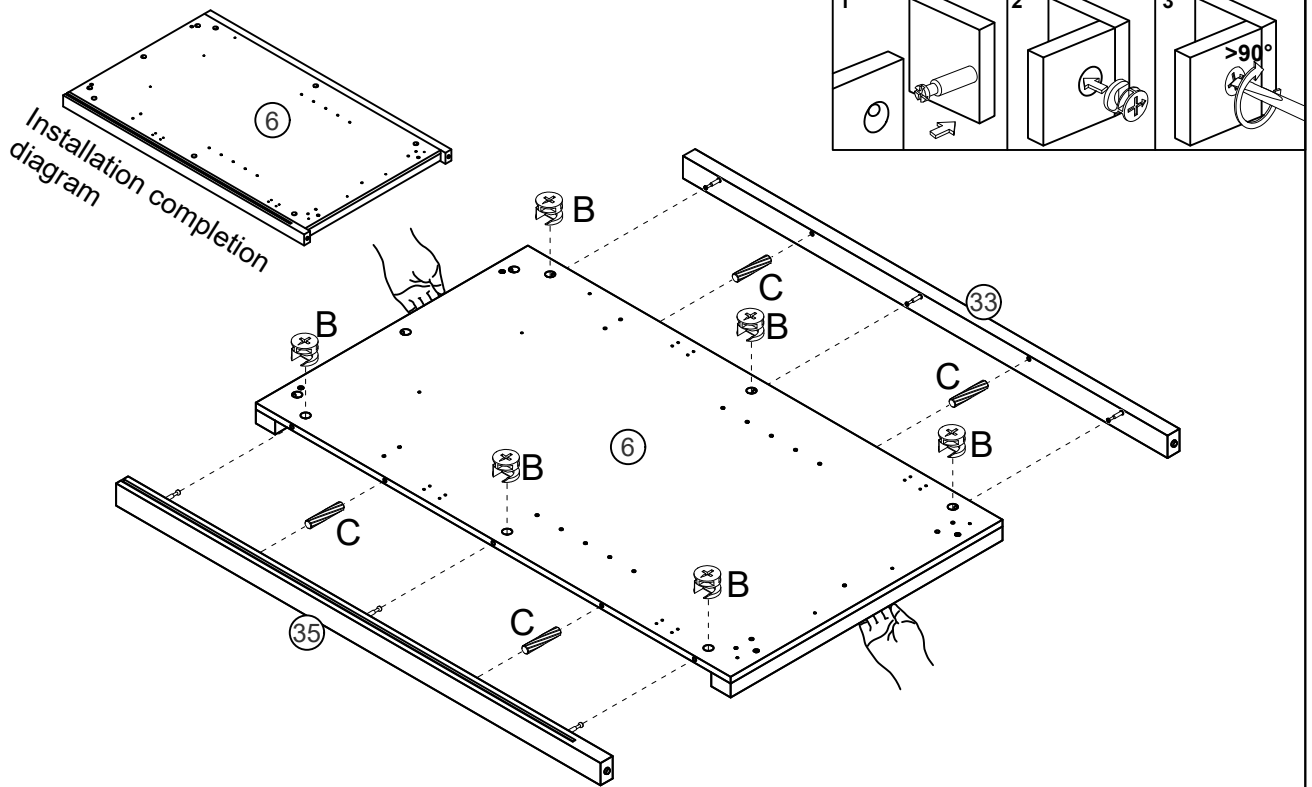

Attach Part #33 and Part #35 to Part #6 with Dowels C x4 and Nuts B x6 as shown.

Then turn Nuts B x6 to secure position.

 B x6

 C x4
Ø6x30mm

29

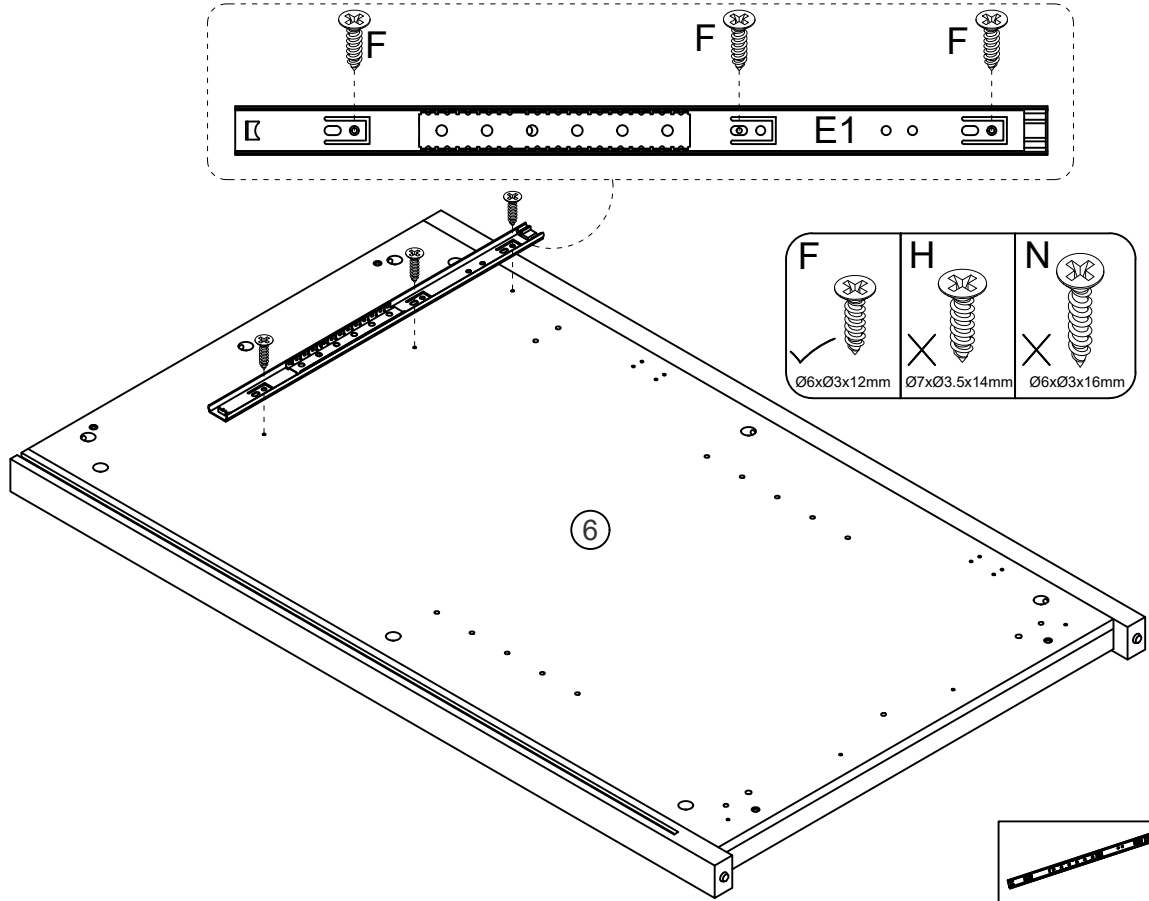

Install outer rail E1 on Part #6 with Screws F x3 as shown.

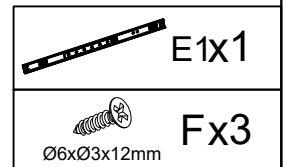

30

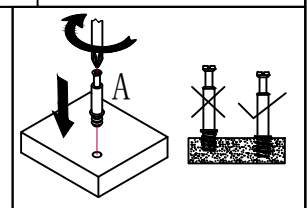
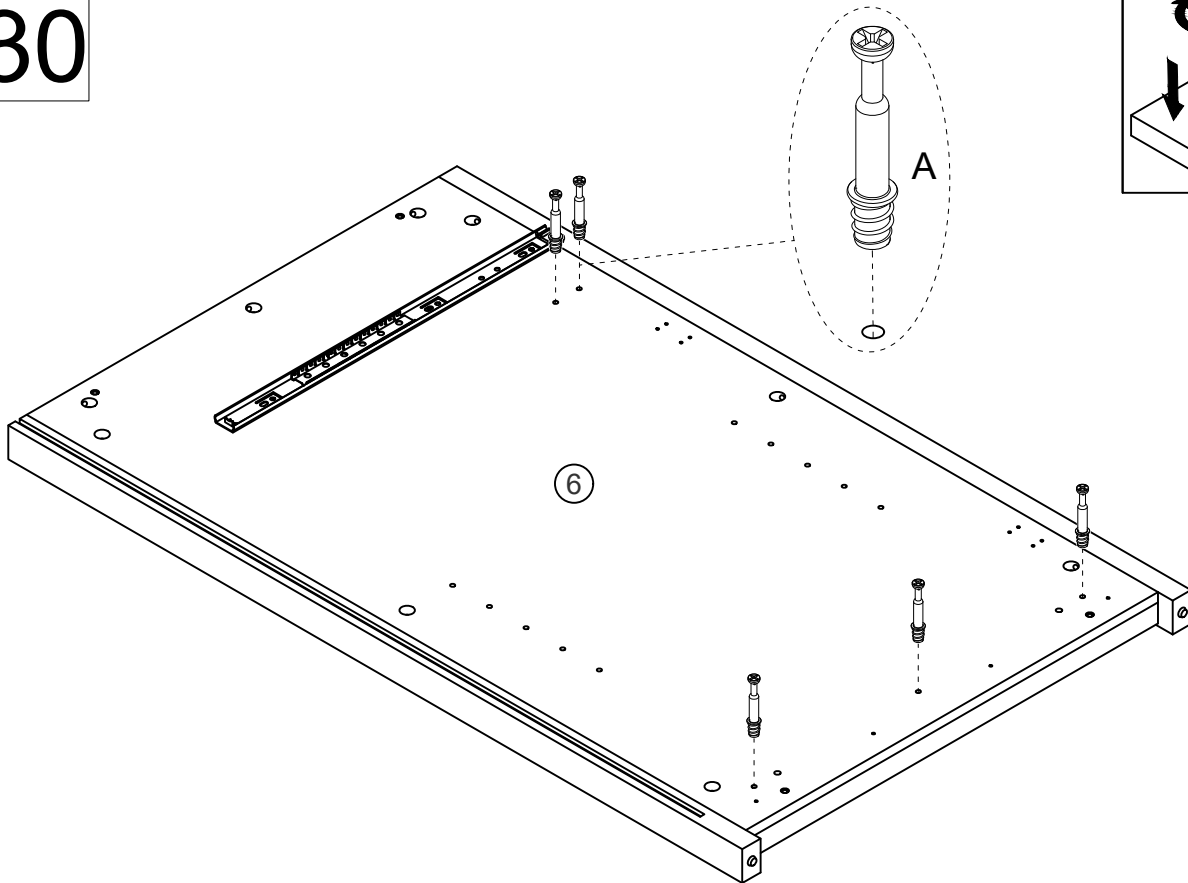

Install Cam Bolt A x5 on Part #6 as shown.

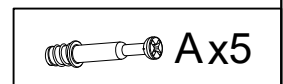

31

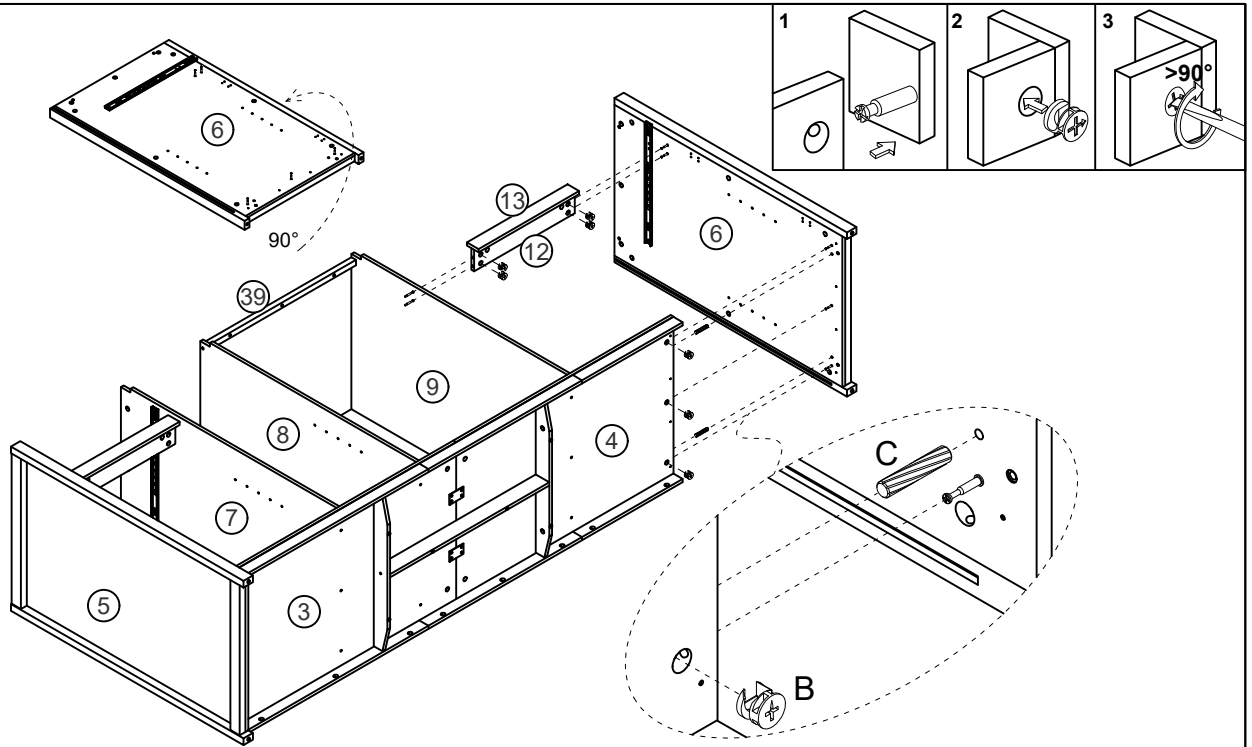

Turn Part #6 90°. Attach Part #6 to Part #4 with Dowels C x2 and Nuts B x3 as shown.

Then attach Part #6 and Part #9 to the assembled unit (Part #12) with Nuts B x4 as shown.

Turn Nuts B x7 to secure position.

	Bx7
Ø6x30mm	Cx2

32

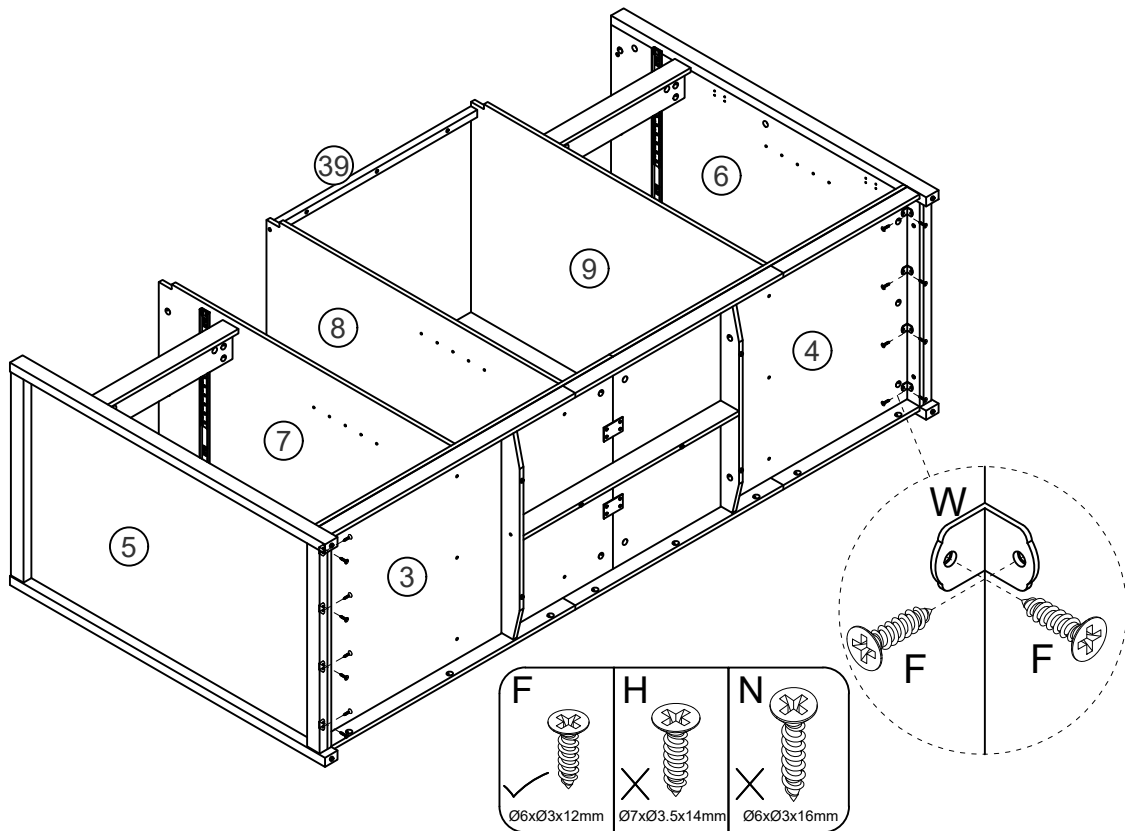

Install W x8 on the assembled unit with Screws F x16 as shown.

Ø6xØ3x12mm	Fx16
	Wx8

33

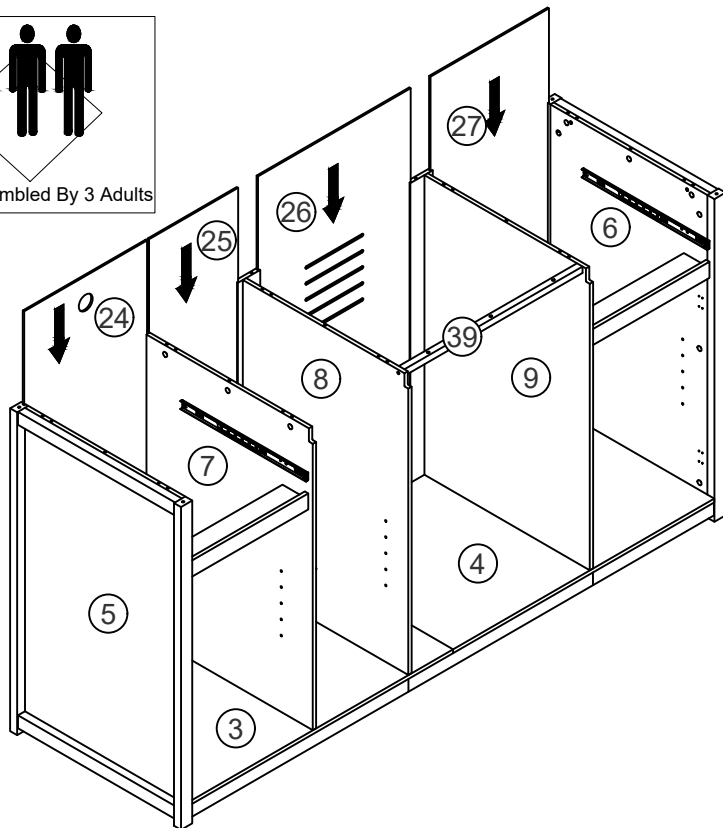
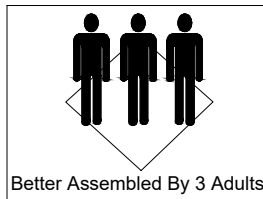
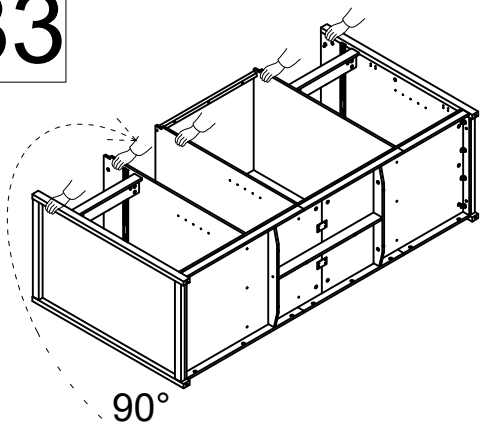

The thin plate needs to be fully inserted into the groove. If the insertion is not smooth, you can try pressing from the front or the back to make adjustments until the thin plate is fully inserted into the groove.

Turn the assembled unit 90°. Then insert Part #24, Part #25, Part #26 and Part #27 into the grooves of the assembled unit as shown. This step should be carried out by three adults.

34

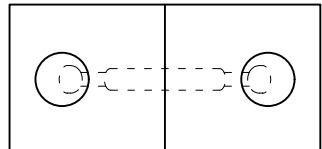
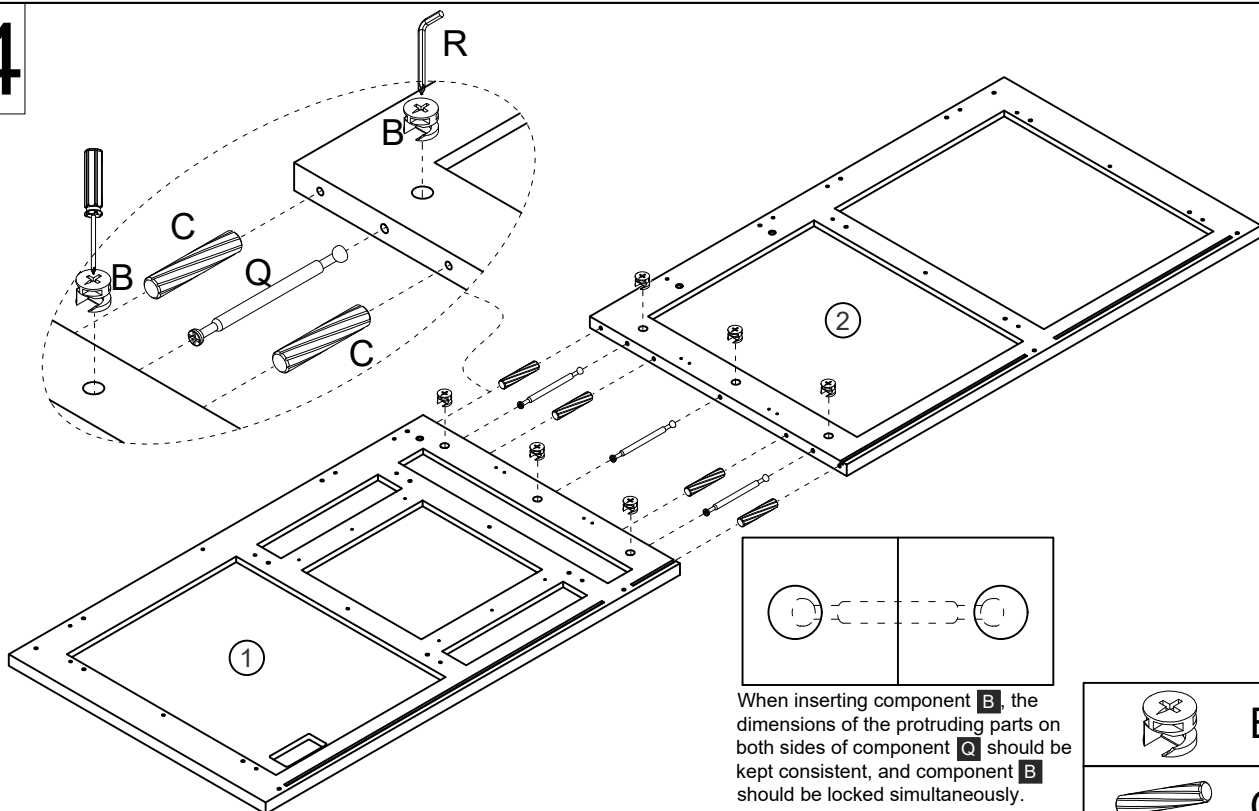

When inserting component **B**, the dimensions of the protruding parts on both sides of component **Q** should be kept consistent, and component **B** should be locked simultaneously.

Connect Part #1 to Part #2 with Q x3, Dowels C x4, and Nuts B x6 as shown. Then tighten the Nuts B on both sides of each Q simultaneously using a screwdriver and tool R as shown.

	Bx6
 Ø6x30mm	Cx4
	Qx3
 4mm	Rx1

35

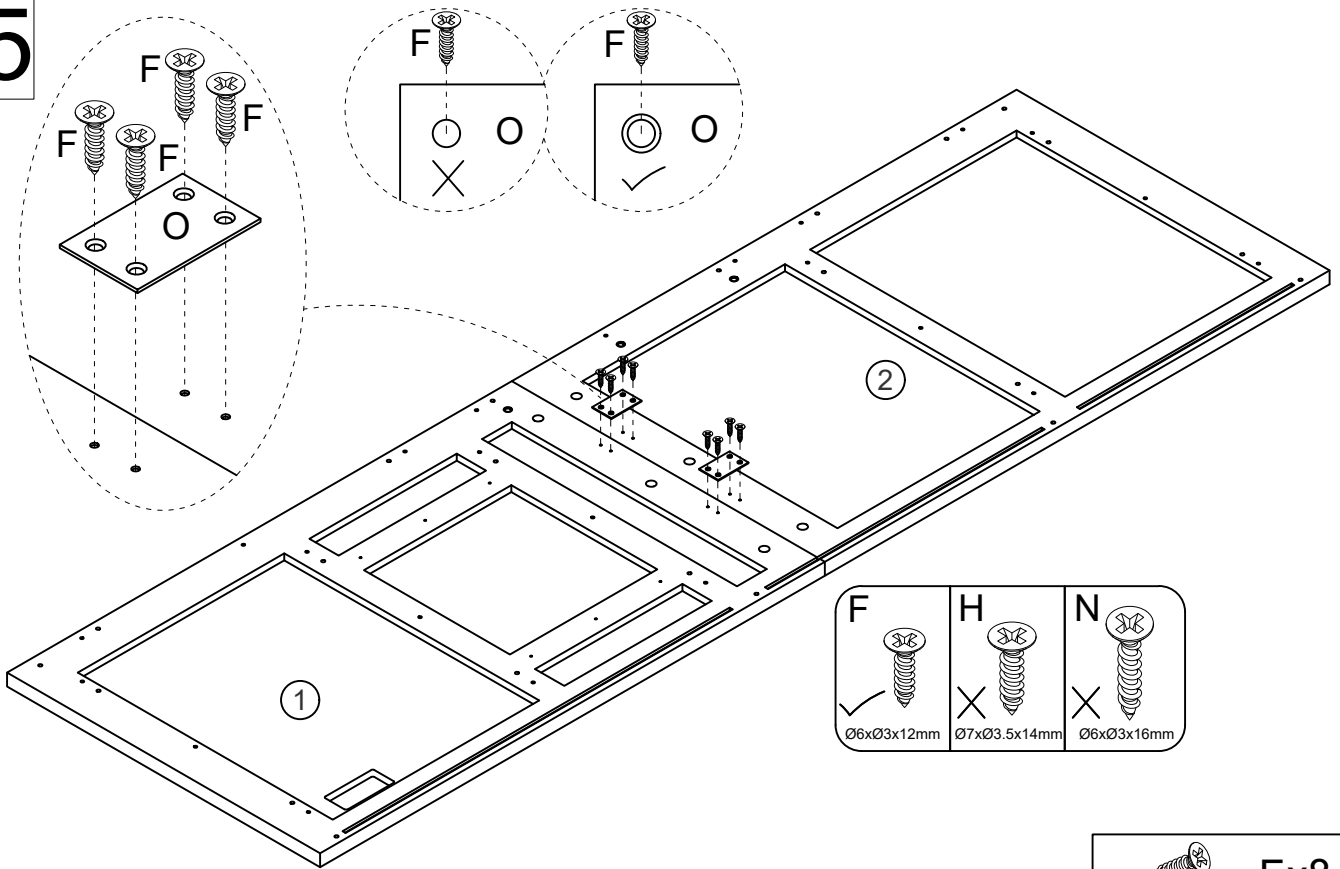

Install O x2 on Part #1 with Screws F x8 as shown.

 Fx8
Ø6xØ3x12mm

 O x2

36

Make sure to install component **J** in the direction shown in the figure.

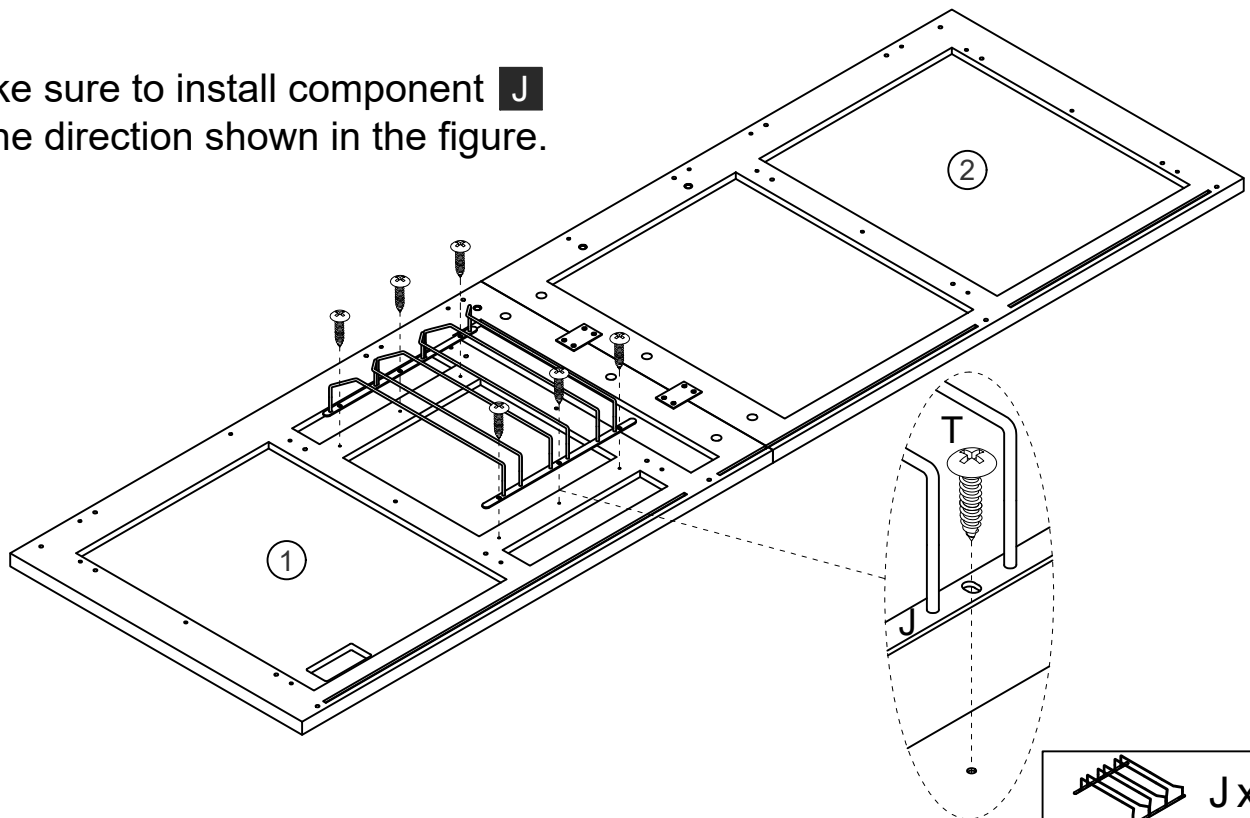

Install J on Part #1 with Screws T x6 as shown.

 J x1

 Tx6
Ø8xØ4x16mm

37

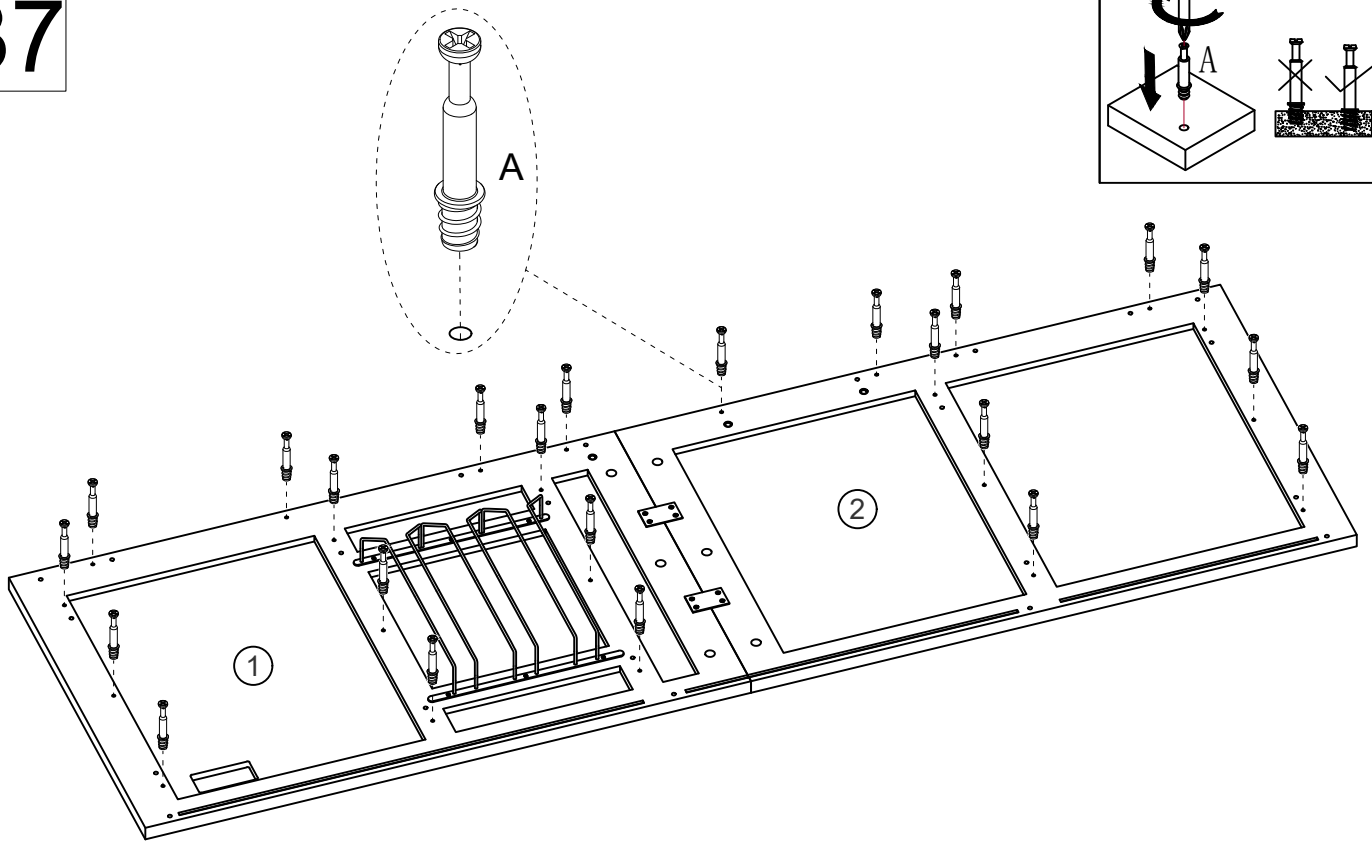

Install Cam Bolt A x23 on Part #1 as shown.



38

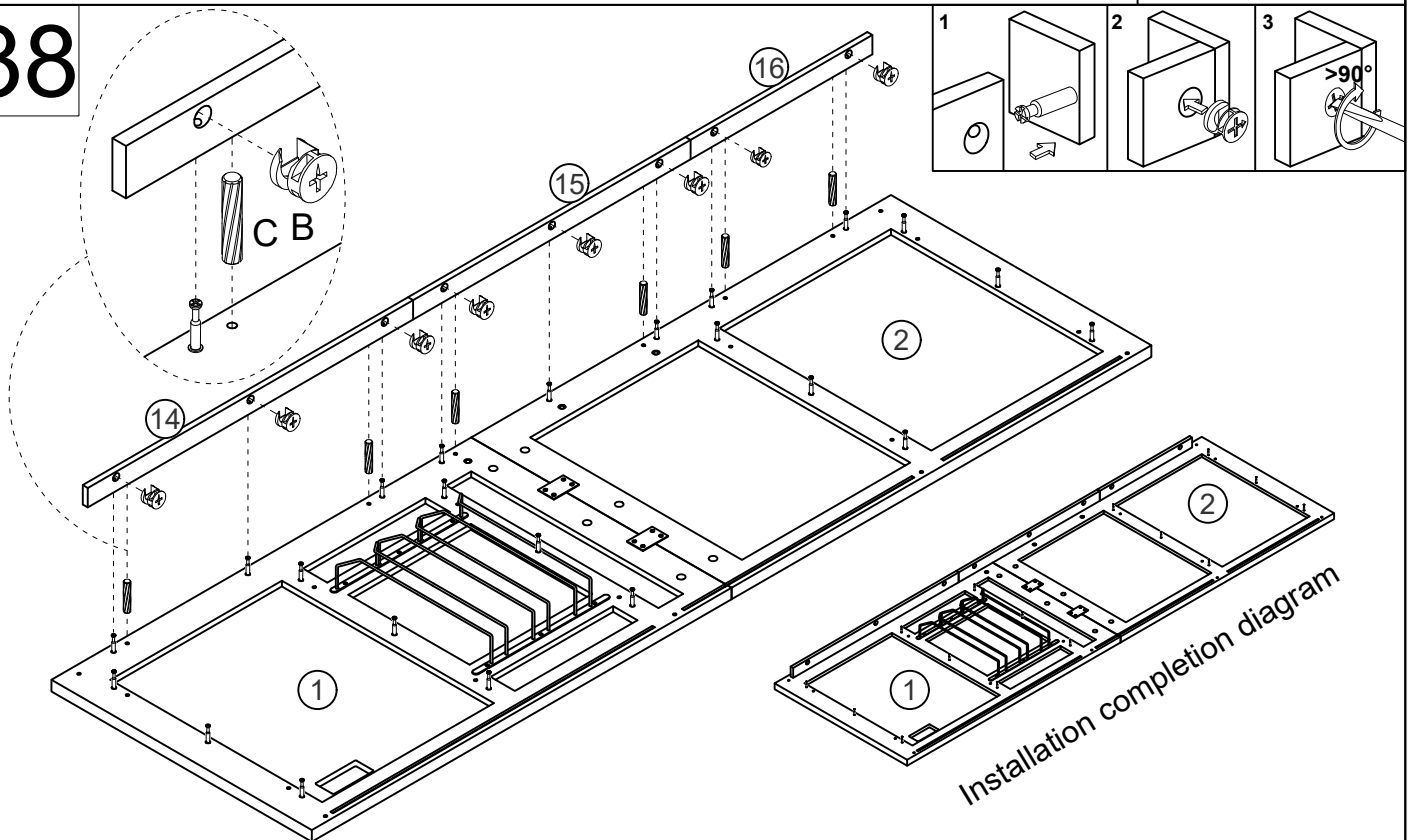

Attach Part #14 , Part #15 and Part #16 to Part #1 with Dowels C x6 and Nuts B x8 as shown. Then turn Nuts B x8 to secure position.



Bx8

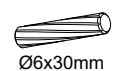

Cx6

39

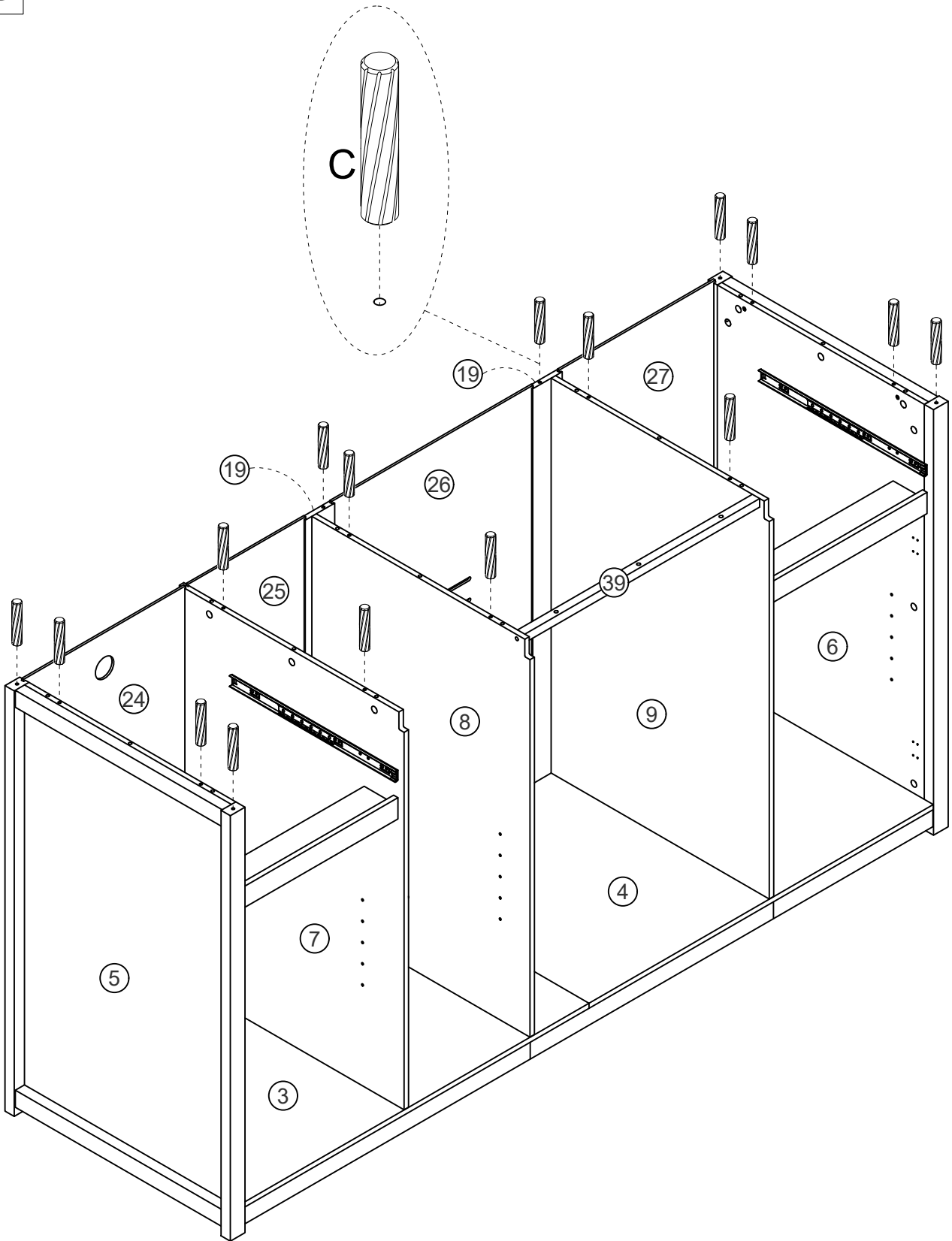

Install Dowels C x16 on the assembled unit as shown.

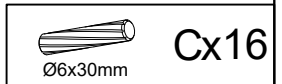

40

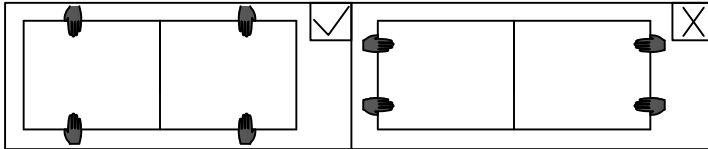

Suggest two people to lift the middle of the tabletop!

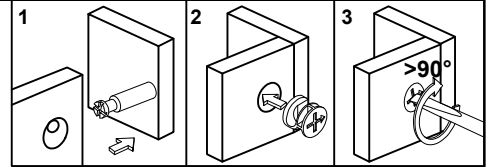

The thin plate needs to be fully inserted into the groove. If the insertion is not smooth, you can try pressing from the front or the back to make adjustments until the thin plate is fully inserted into the groove.

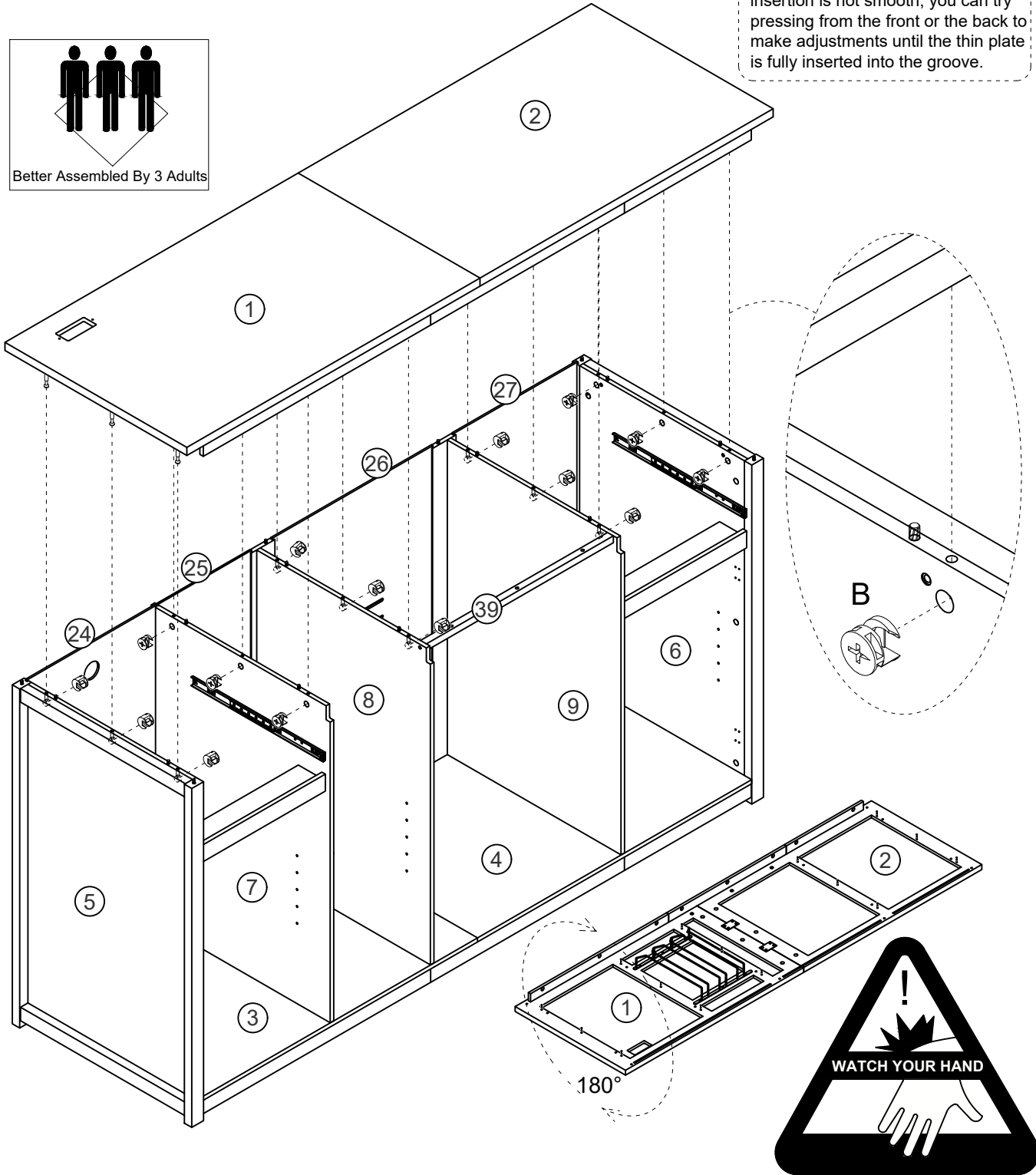
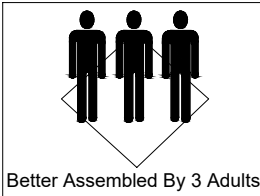

Turn Part #1 180°. Then attach Part #1 to the assembled unit with Nuts B x15 as shown.
Turn Nuts B x15 to secure position.
This step should be carried out by three adults.



41

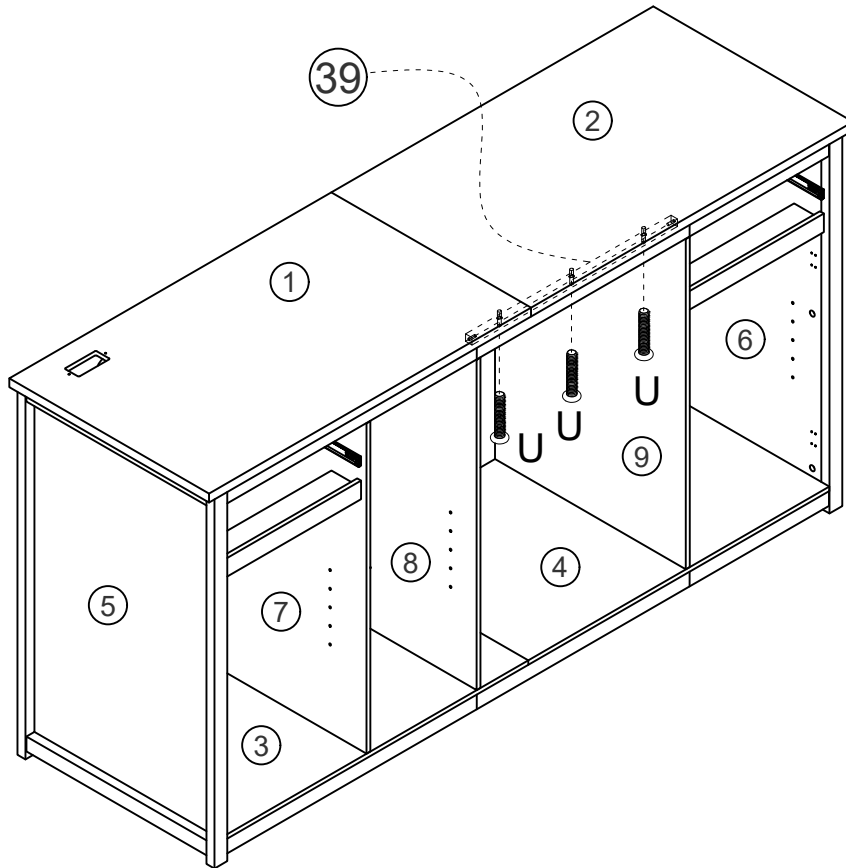

Secure Part #39 to Part #1 with Screws U x3 as shown.



Rx1



Ux3

M6x35mm

42

First, insert the wires of the socket through the holes in the back panel.

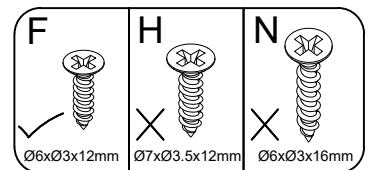
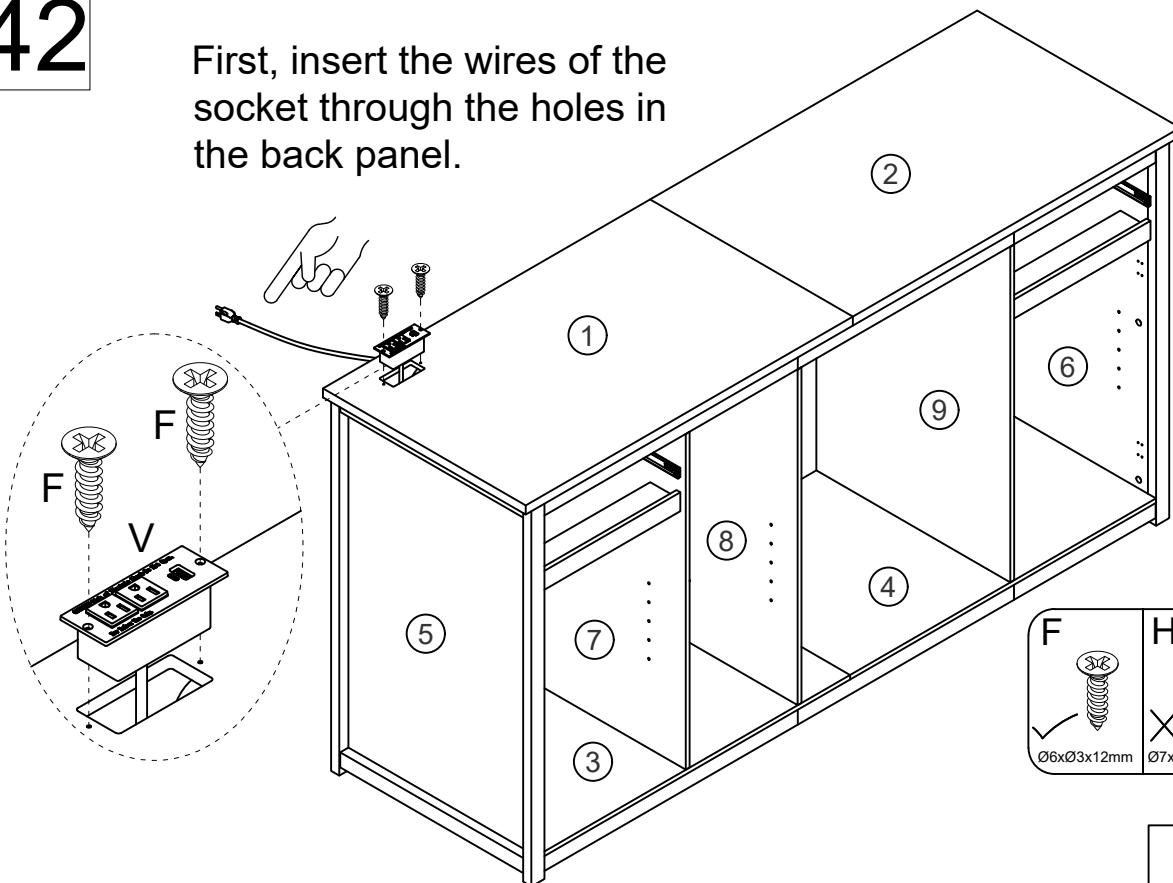

Fx2

Ø6xØ3x12mm



Vx1

Install socket V on Part #1 with Screws F x2 as shown.

43

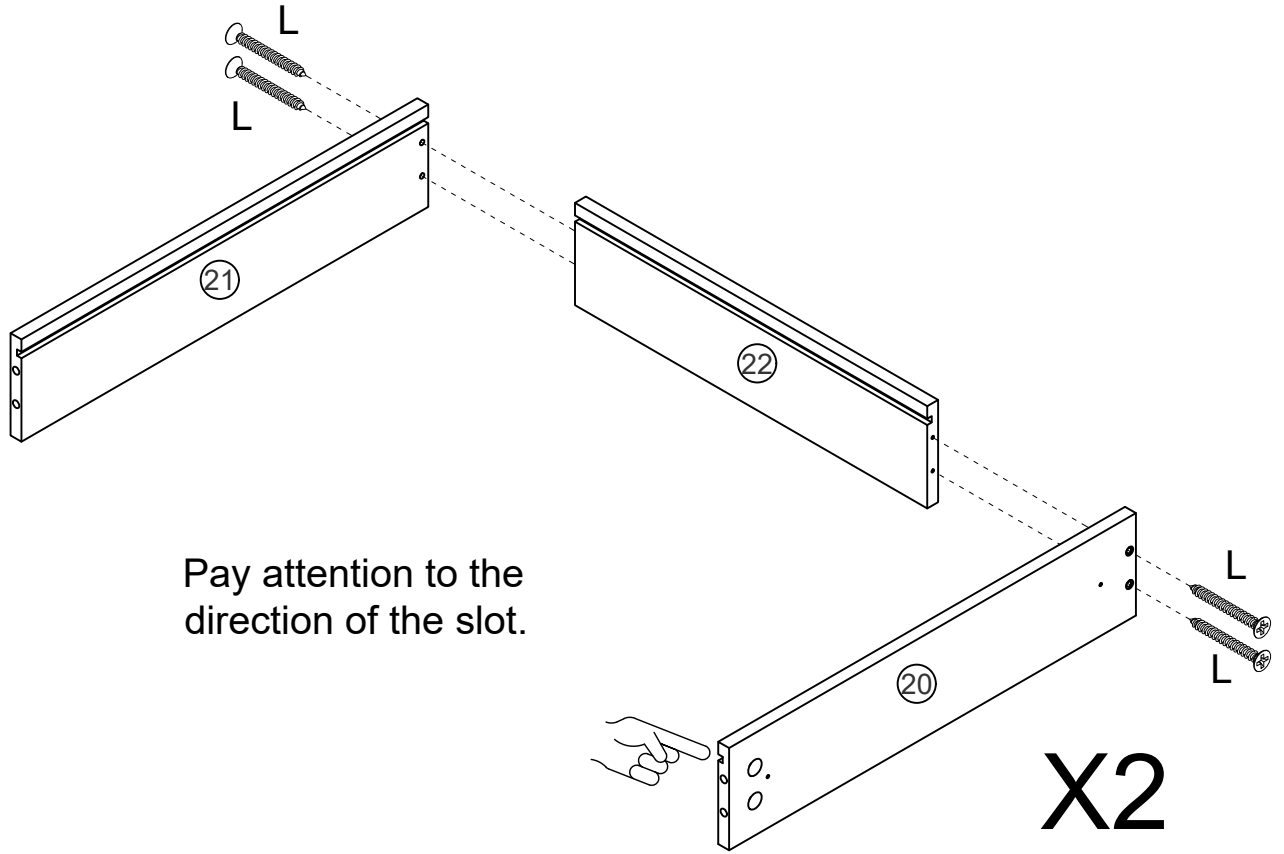

Attach Part #20 x2 and Part #21 x2 to Part #22 x2 with Screws L x8 as shown.



44

The thin plate needs to be fully inserted into the groove. If the insertion is not smooth, you can try pressing from the front or the back to make adjustments until the thin plate is fully inserted into the groove.

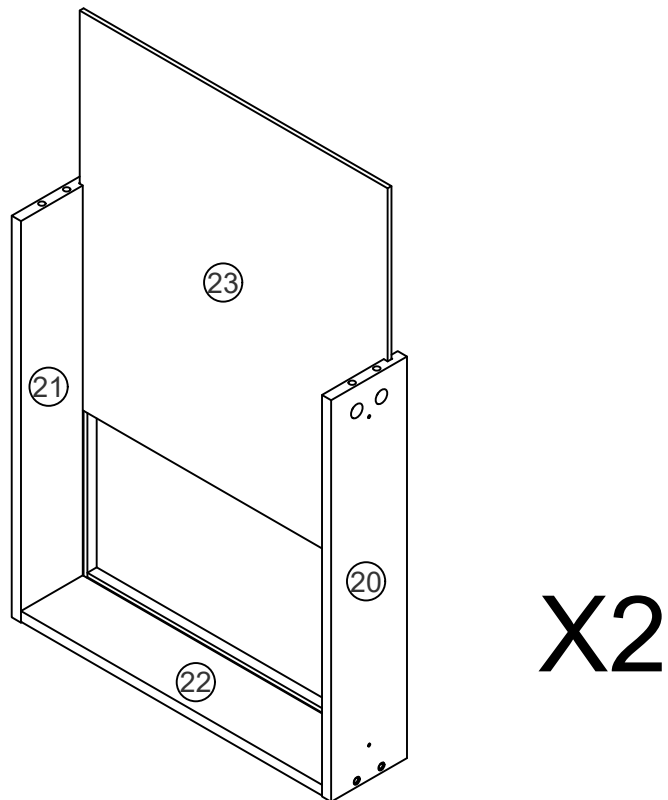

Insert Part #23 x2 into the grooves of the assembled unit x2 as shown.

45

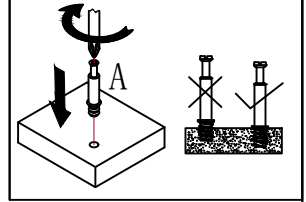
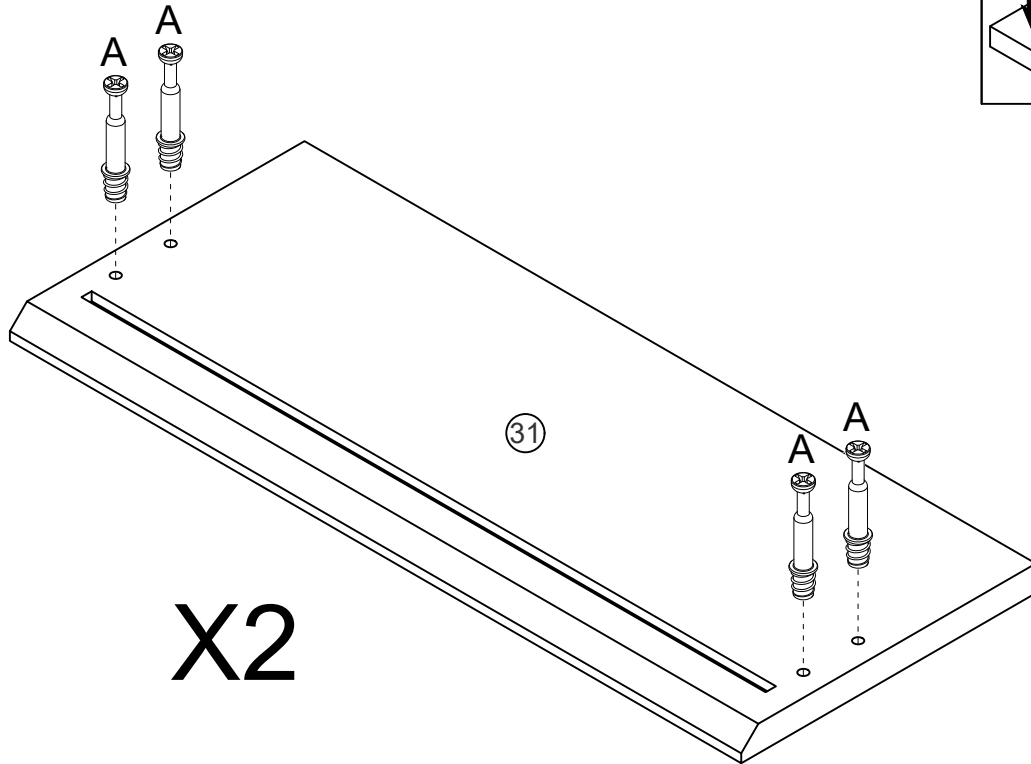

X2

Install Cam Bolt A x8 on Part #31 x2 as shown.

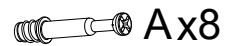

46

X2

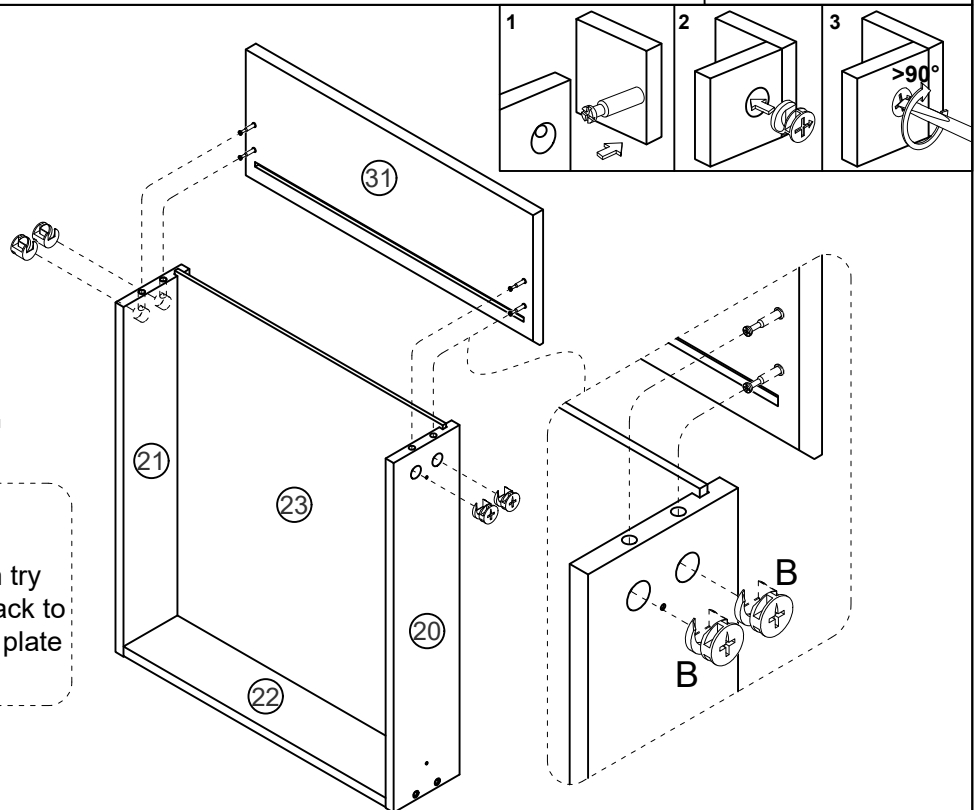

The thin plate needs to be fully inserted into the groove. If the insertion is not smooth, you can try pressing from the front or the back to make adjustments until the thin plate is fully inserted into the groove.

Attach Part #31 x2 to the assembled unit x2 from Step 44 with Nuts B x8 as shown.

Then turn Nuts B x8 to secure position.



47

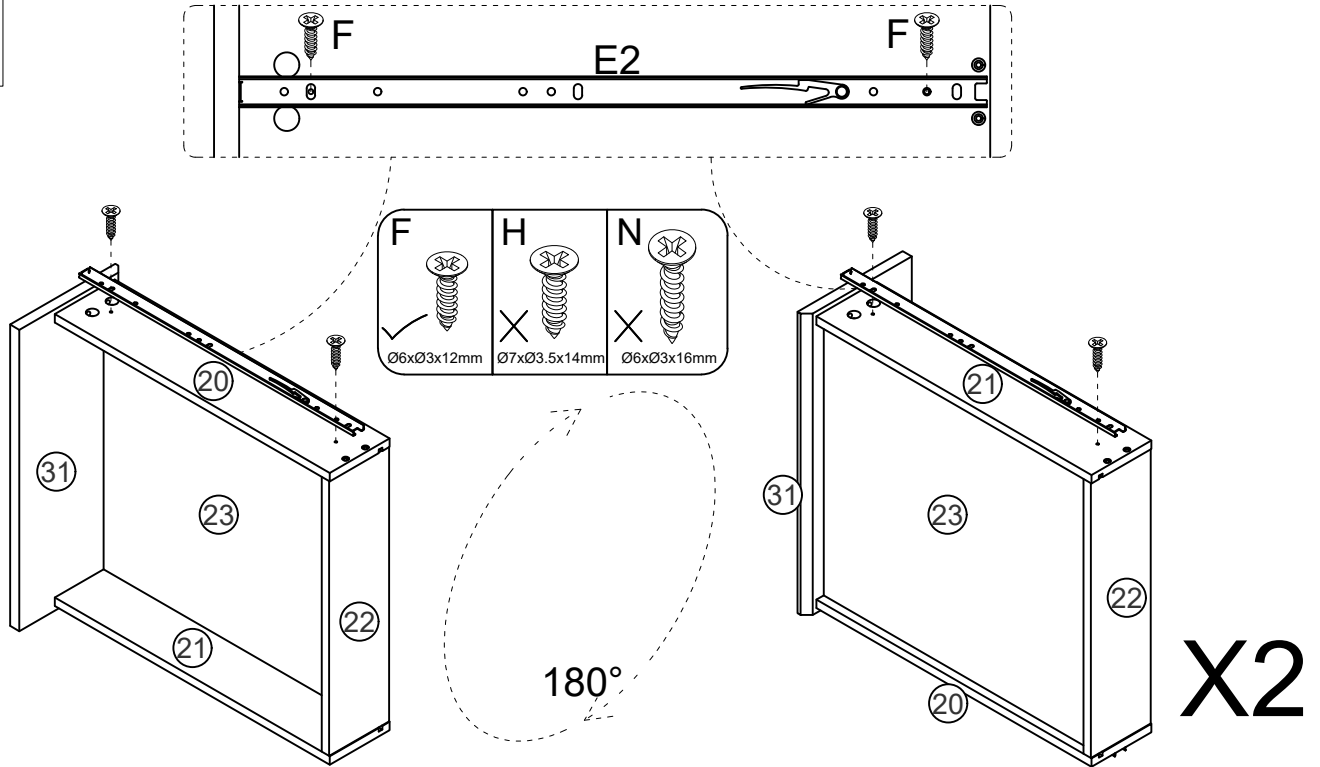

Install inner rail E2 x2 on Part #20 x2 of the drawers with Screws F x4 as shown. Then turn the Drawers x2 180°. Install inner rail E2 x2 on Part #21 x2 of the drawers with Screws F x4 as shown.

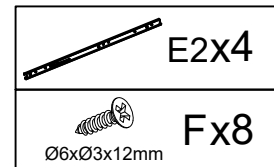

48

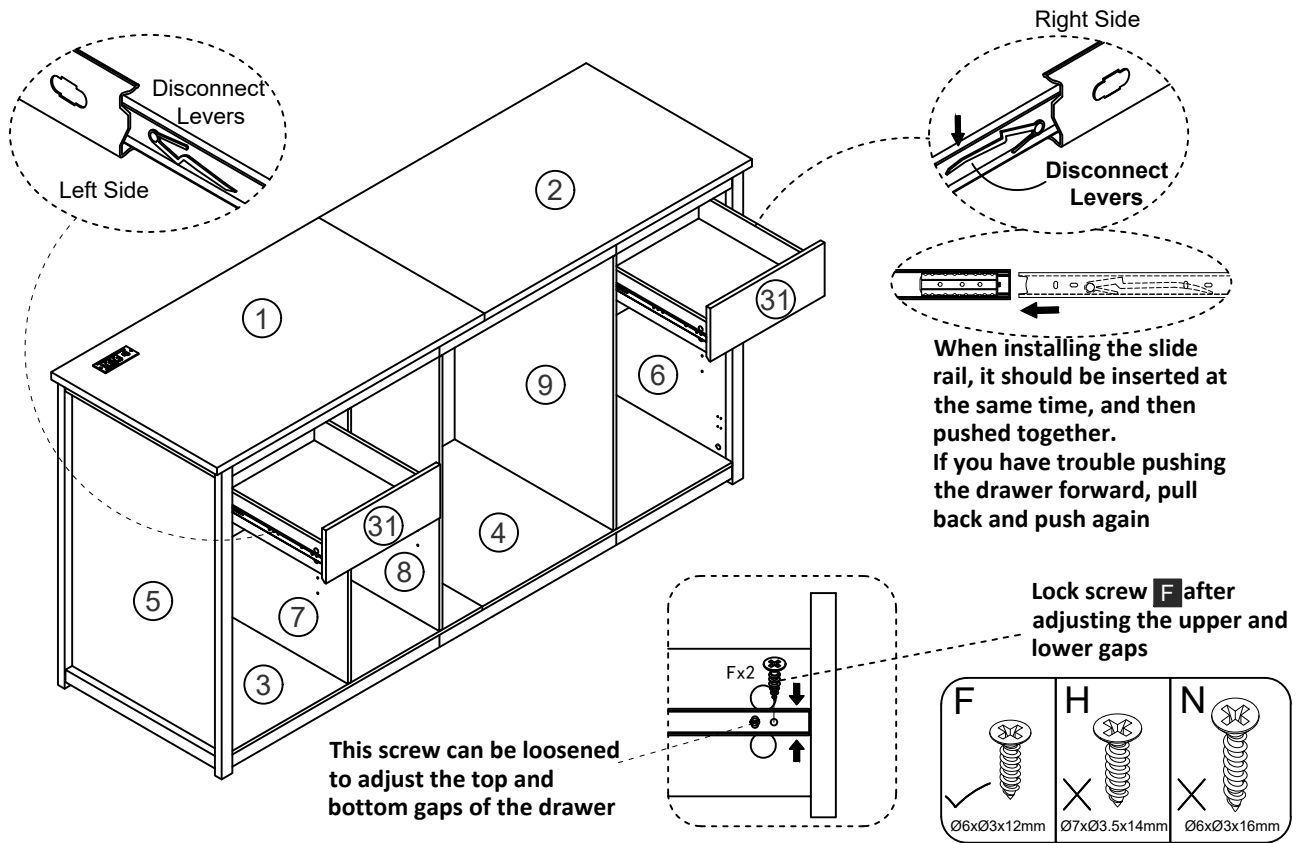

Insert the inner rail E2 x4 into the outer rail E1 x4 as shown. After adjusting the upper and lower gaps, lock screws F x4 onto the inner slides E2 x4 as shown.

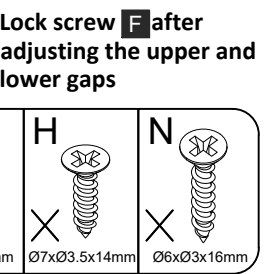

49

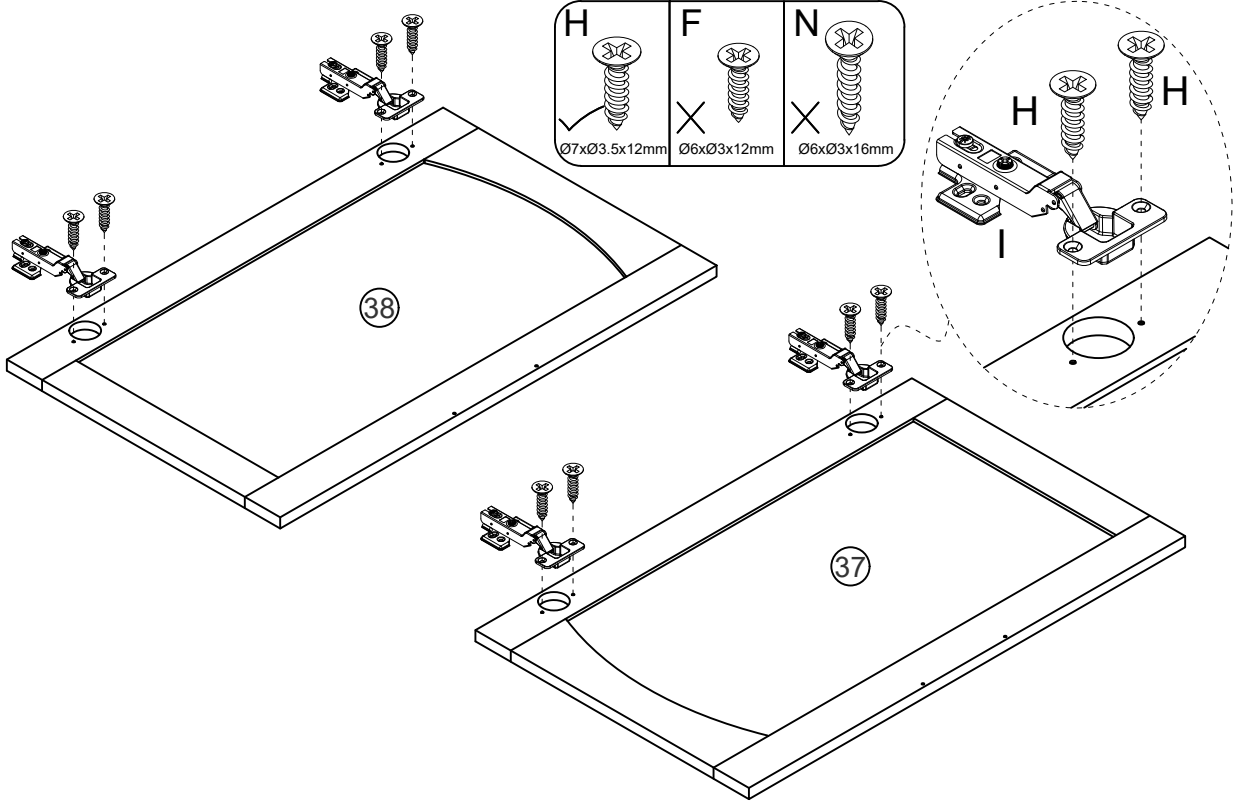

Install hinge I x4 on Part #37 and Part #38 with Screws H x8 as shown.

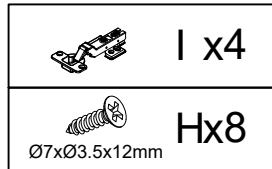

50

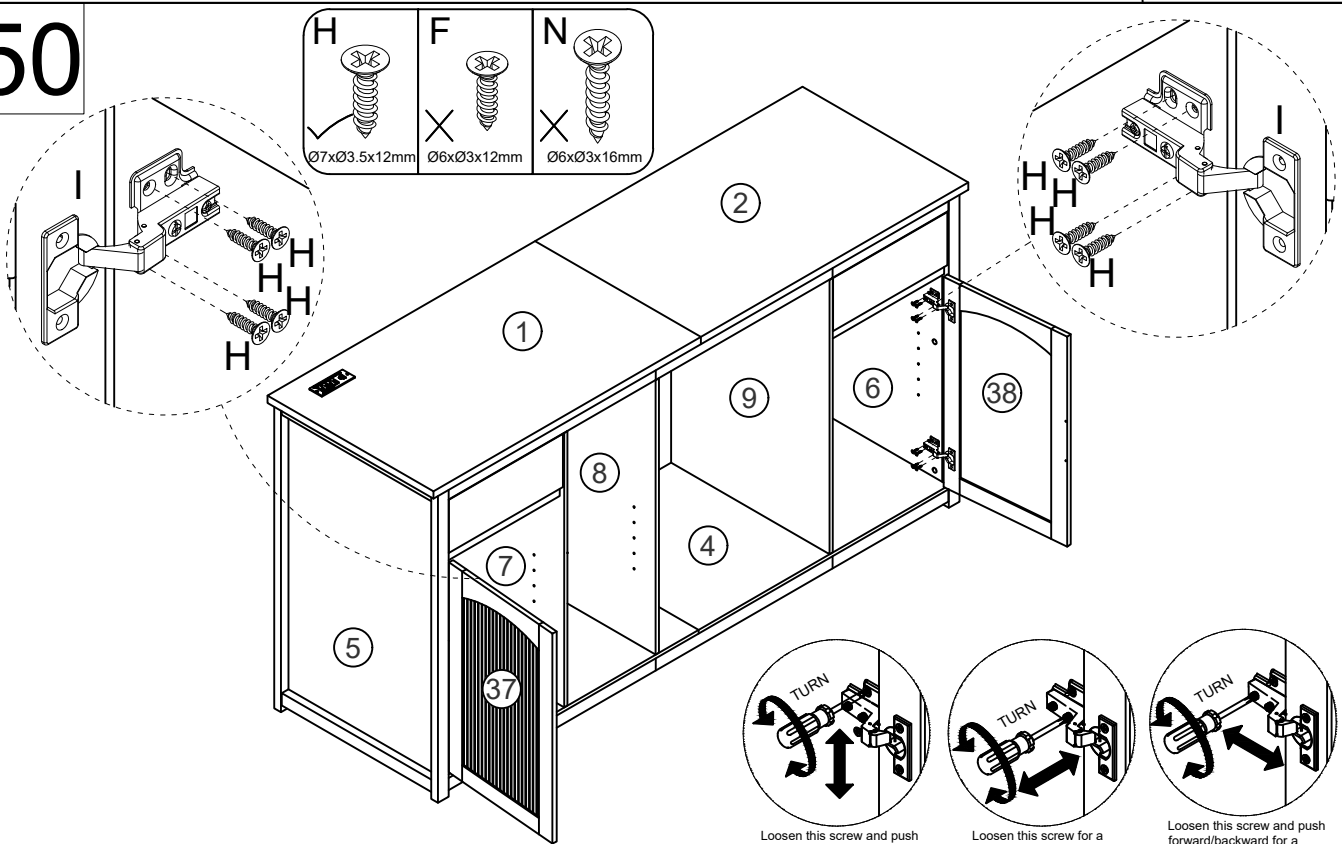

Attach Part #37 and Part #38 to the assembled unit with Screws H x16 as shown.



51

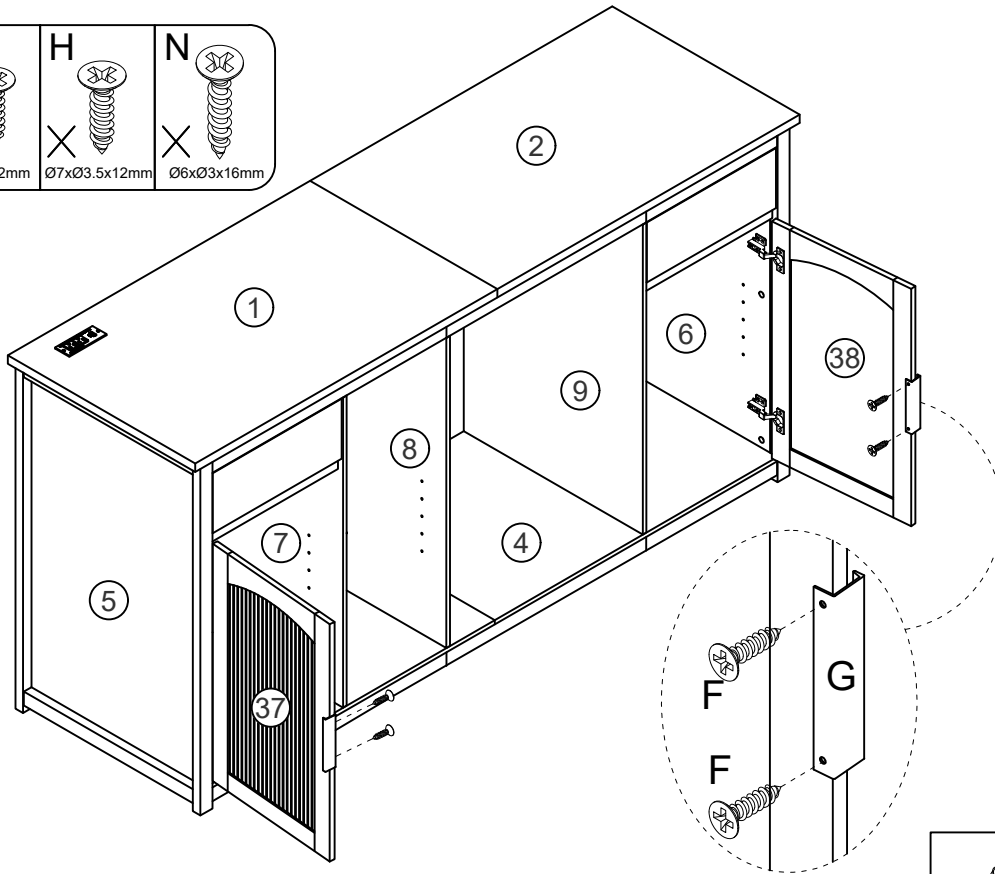
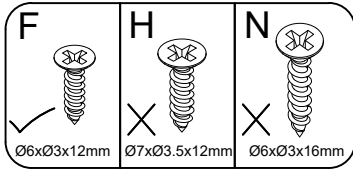

Install handle G x2 on Part #37 and Part #38 with Screws F x4 as shown.



52

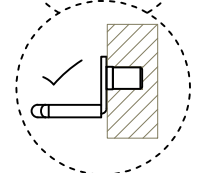
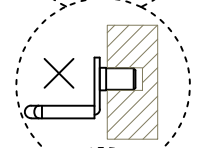
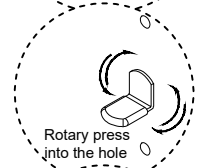
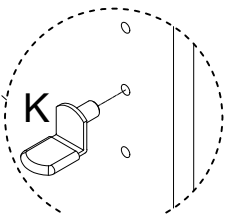
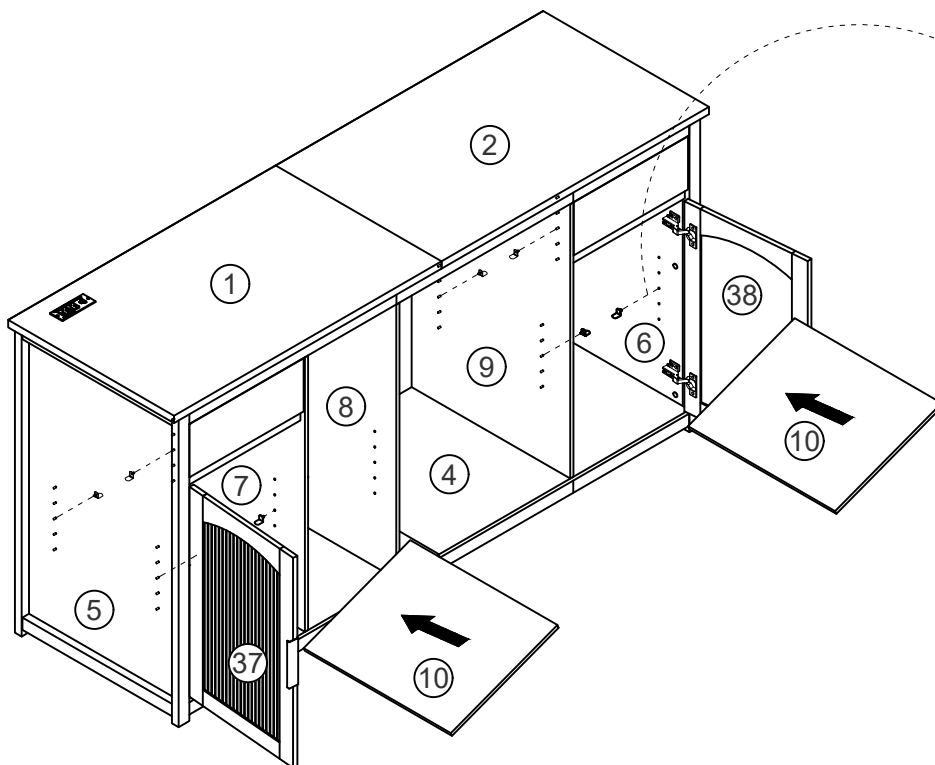

Install adjustable shelf supports K x8 on the assembled unit. Then put Part #10 x2 on K as shown.



53

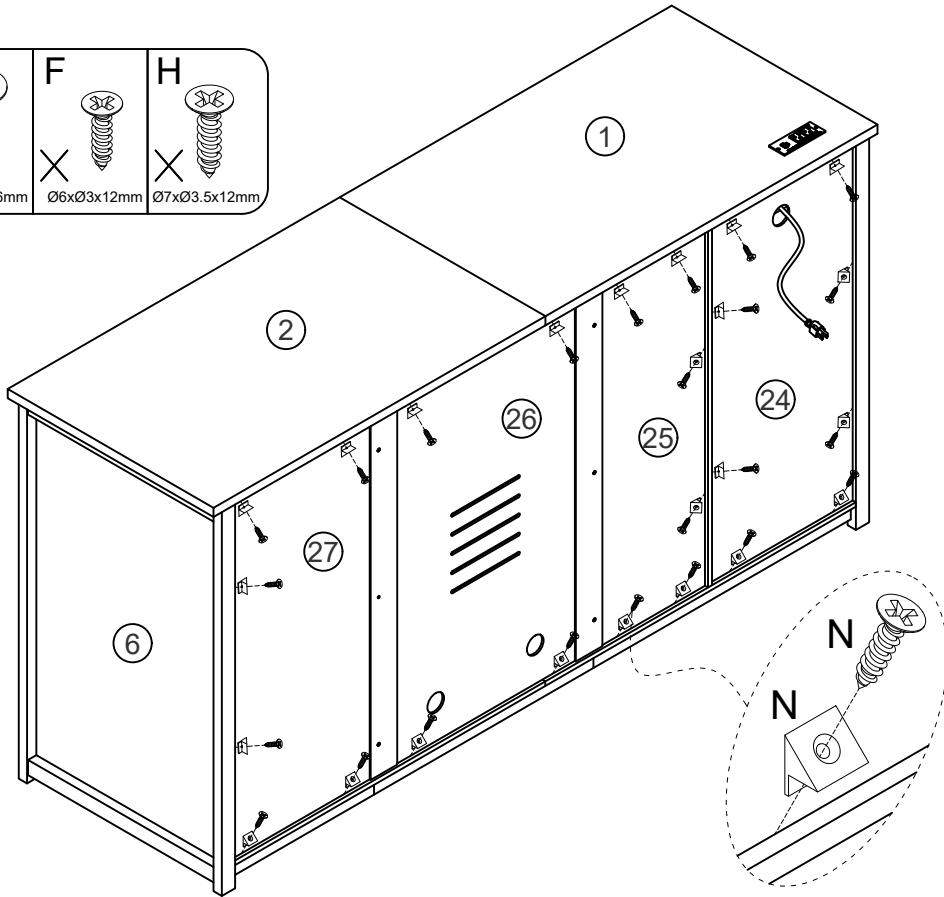
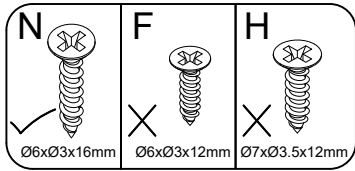

Install N x 24 on the assembled unit as shown.



54

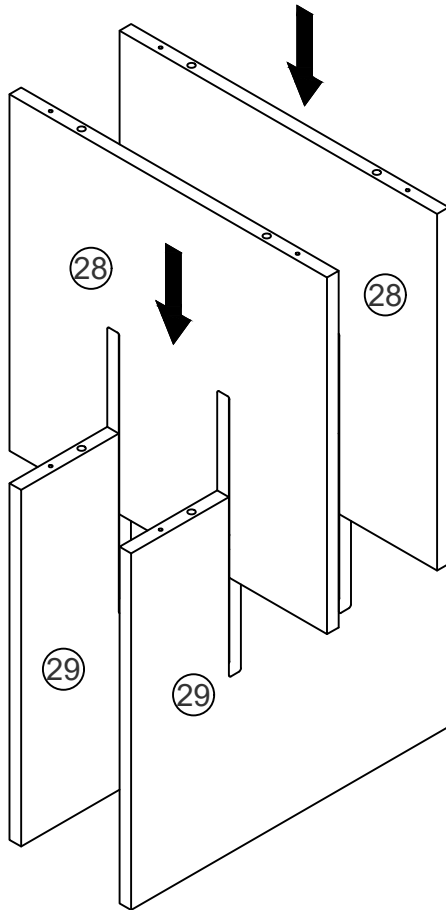

Insert Part #28 x2 into Part #29 x2 as shown.

55

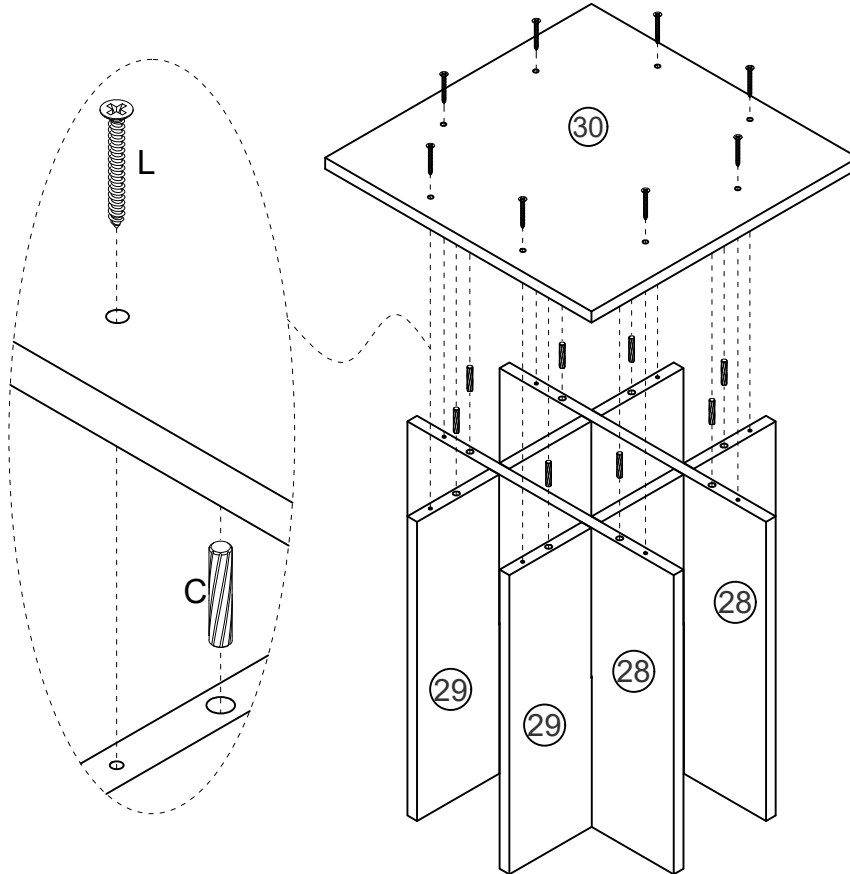

Attach Part #30 to the assembled unit with Dowels C x8 and Screws L x8 as shown.

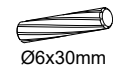

Cx8

Ø6x30mm



Lx8

Ø8xØ4x32mm

56

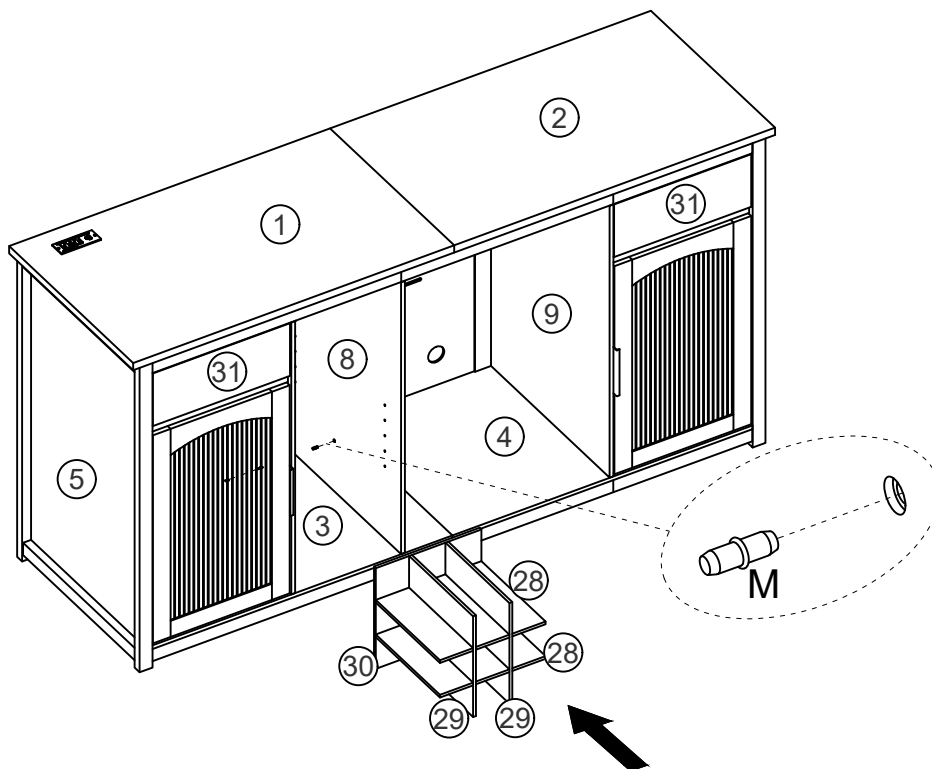

Install stoppers M x2 on Part #7 and Part #8 of the assembled unit. Then slide the assembled unit from Step 55 into the cabinet.



Mx2

57

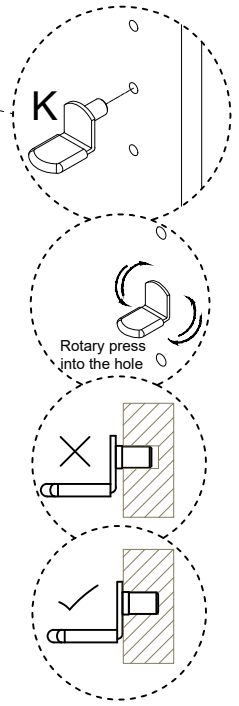
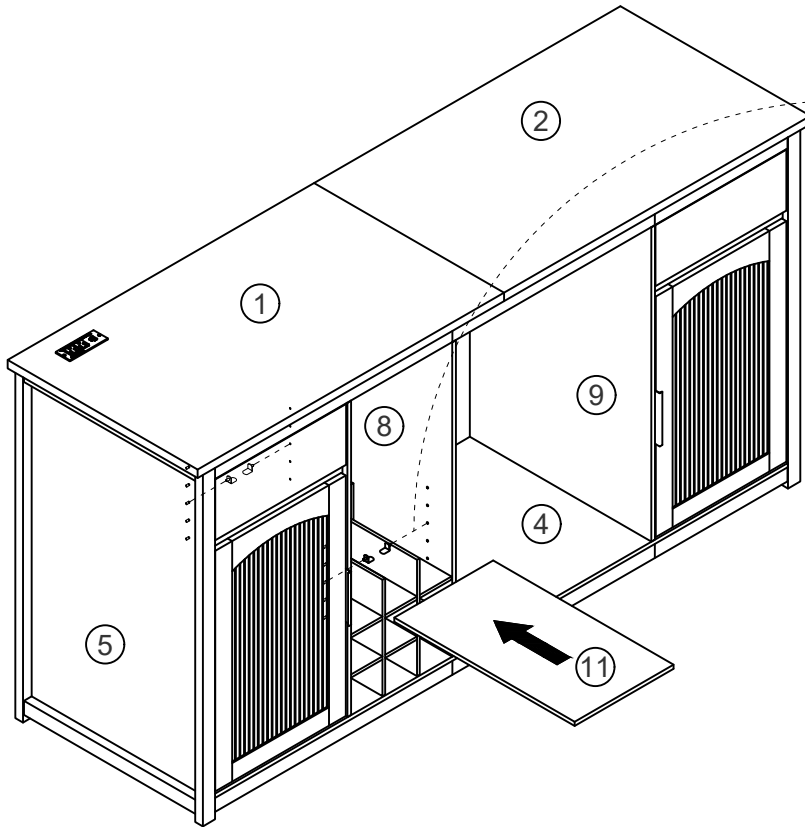

Install adjustable shelf supports K x4 on the assembled unit.
Then put Part #11 on K as shown.



58

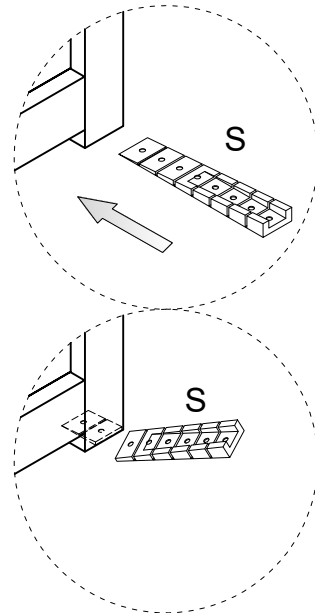
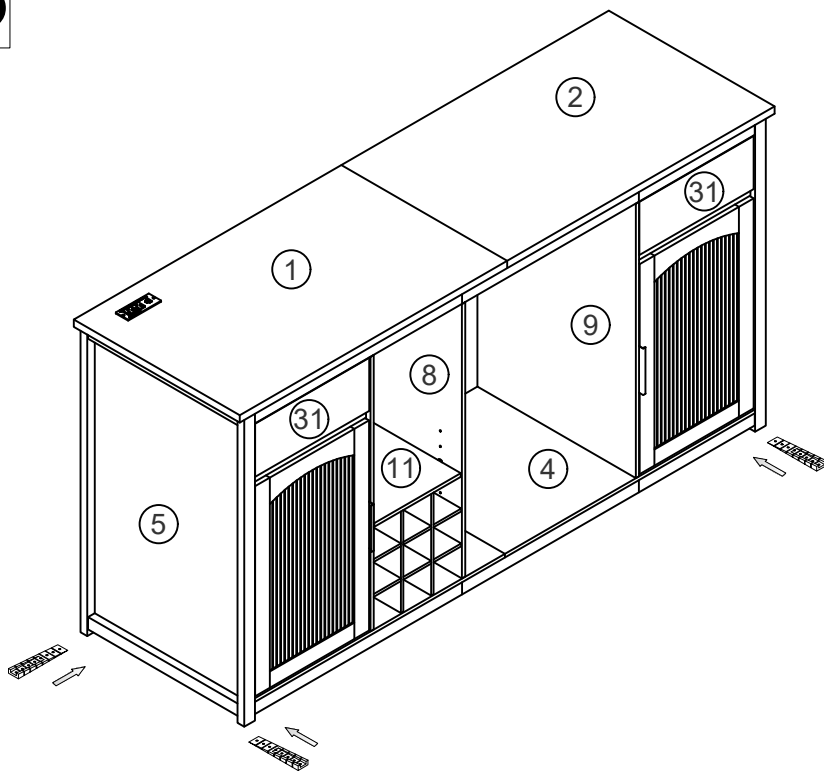

(Optional)

Install spacer S x6 to the assembled unit as shown if needed.

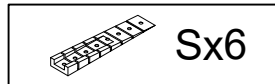

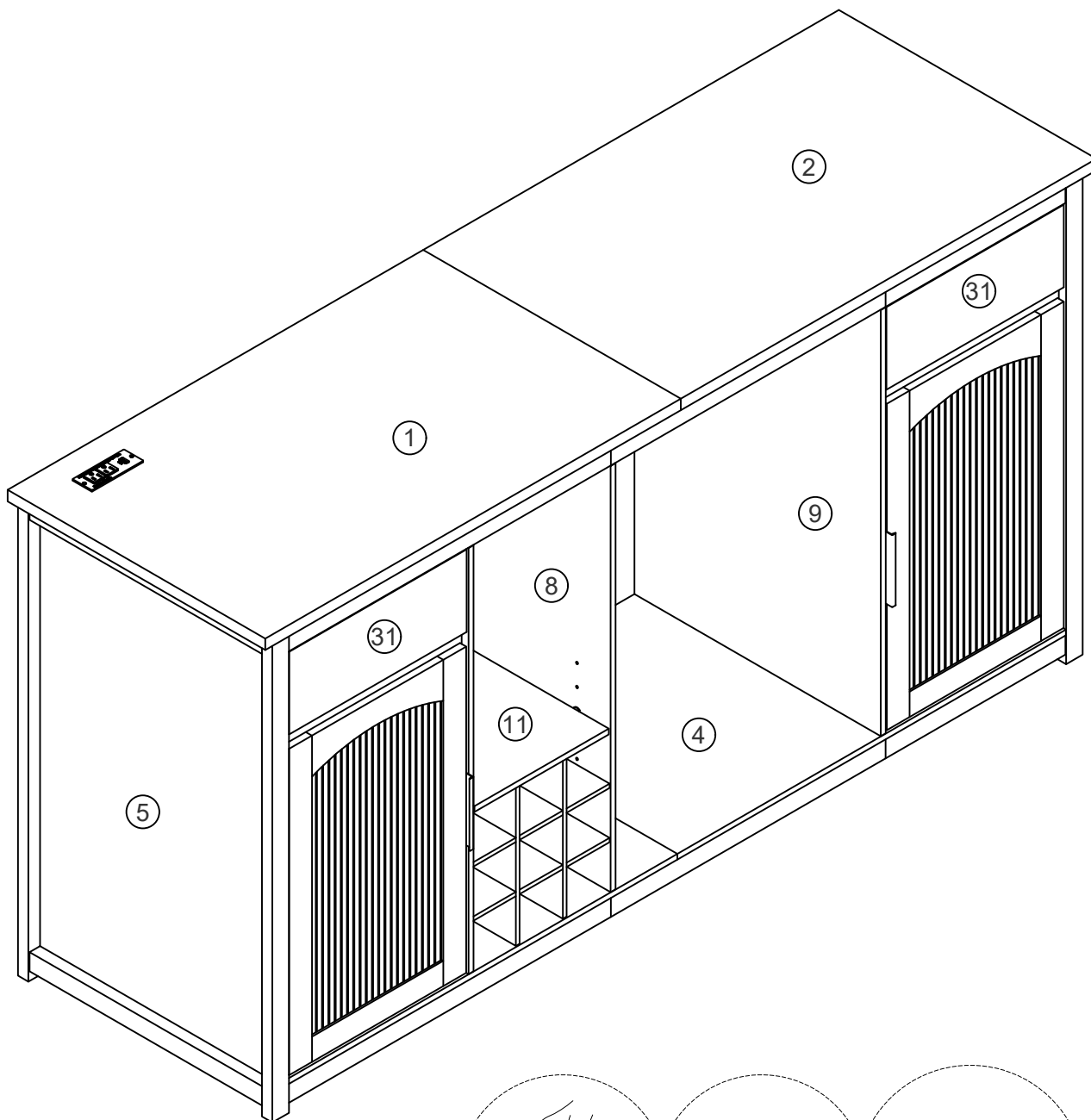

We provide round stickers P x55. You can stick it to cover the exposed nuts or holes so as to look nicer.



Px55