

ASSEMBLY INSTRUCTION

Thank you for purchasing the quality product. Be sure to check all packing material carefully for small parts which may have come loose inside the carton during shipment. Separate, identify and count all parts and metal hardware. Compare with all parts are present. If any part(s) are missing or damaged, please contact your local furniture dealer. For efficient and speedy service, please indicate the model number and code letter of part(s) needed.

*****Do not fully tighten screws until fully assembled.*****

DRESSER



DIMENSIONS

Width - 47.24"
Depth - 16.22"
Height - 30.14"

ASSEMBLY INSTRUCTIONS

PRECAUTIONS

Because our products may be challenging for beginners, we deeply understand that you may encounter some difficulties. To avoid discouragement, we have provided some useful tips, as follows.

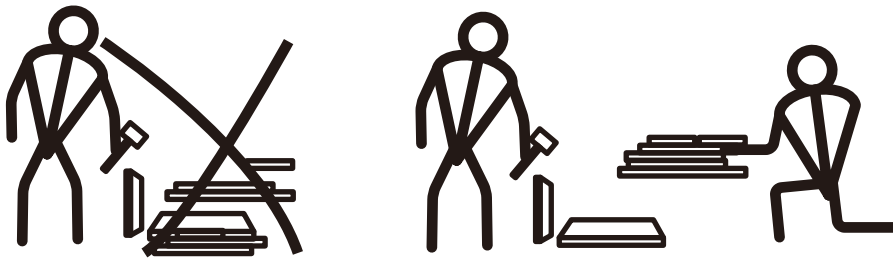

Enough Open Space -

Ensure that there is enough space for movement during assembly.

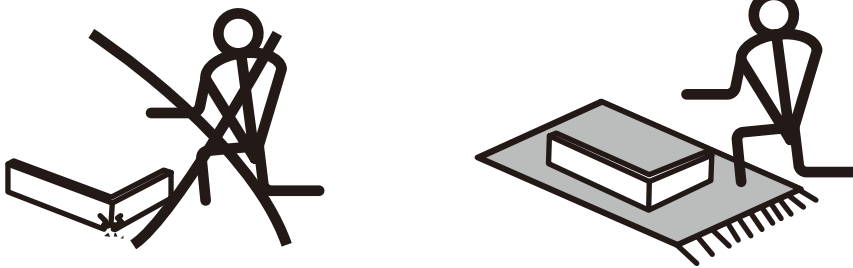

Prevent Scratching -

When assembling furniture, use cardboard, blankets or a carpet areas to prevent scratches.

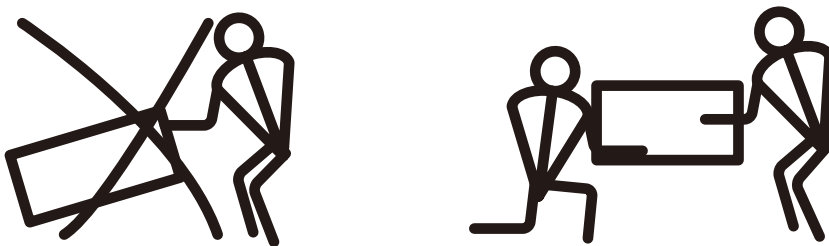

More than two people -

Always have at least two people to help transport and assemble the product to avoid potential injury and/or damage.

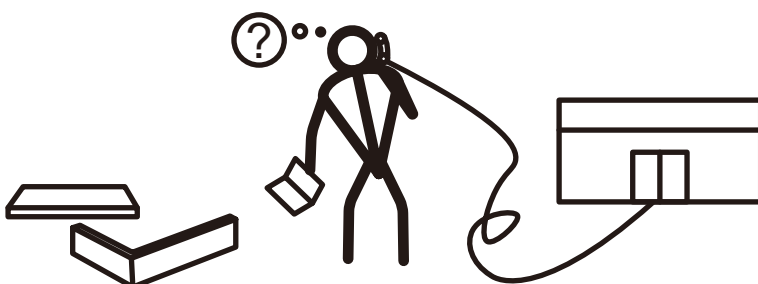

Question -

If there is any problem with the assembly process, you can call us.

ASSEMBLY INSTRUCTIONS

CAM LOCK FASTENER

Every cam bolt must have a cam lock connector to hold the parts together.

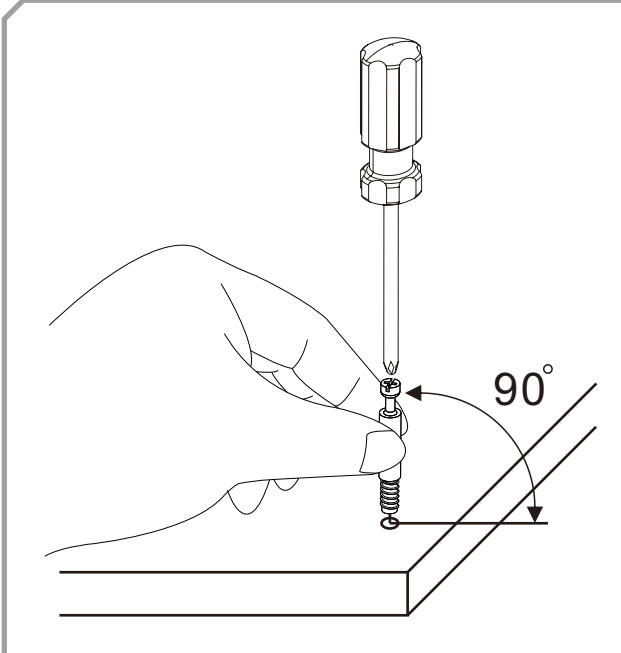

1.
When assembling, the hardware parts and the wooden board must be kept vertical, and the tools must be in full contact with the hardware groove.

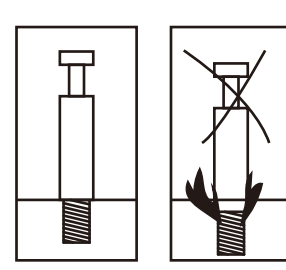

Caution:
Do not use excessive force to avoid overfastening, or even exceed the entire board.

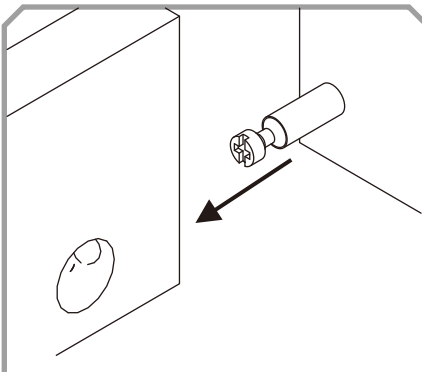

2.
Insert the cam lock pin into the hole of joint panel.

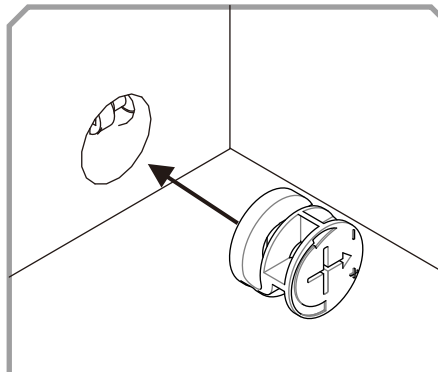

3.
The cam lock nut opening side (or arrow) aligned with the cam lock pin.

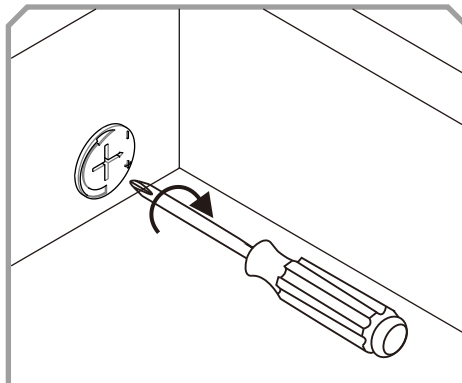

4.
Slowly rotate the cam lock clockwise until it stops rotating.



Caution:
When assembling the cam lock, do not use an electric screwdriver to avoid damage to the board or hardware due to excessive force.

ASSEMBLY INSTRUCTIONS

SLIDE RAIL

The holes of the slide rail are in the same direction as the following page.

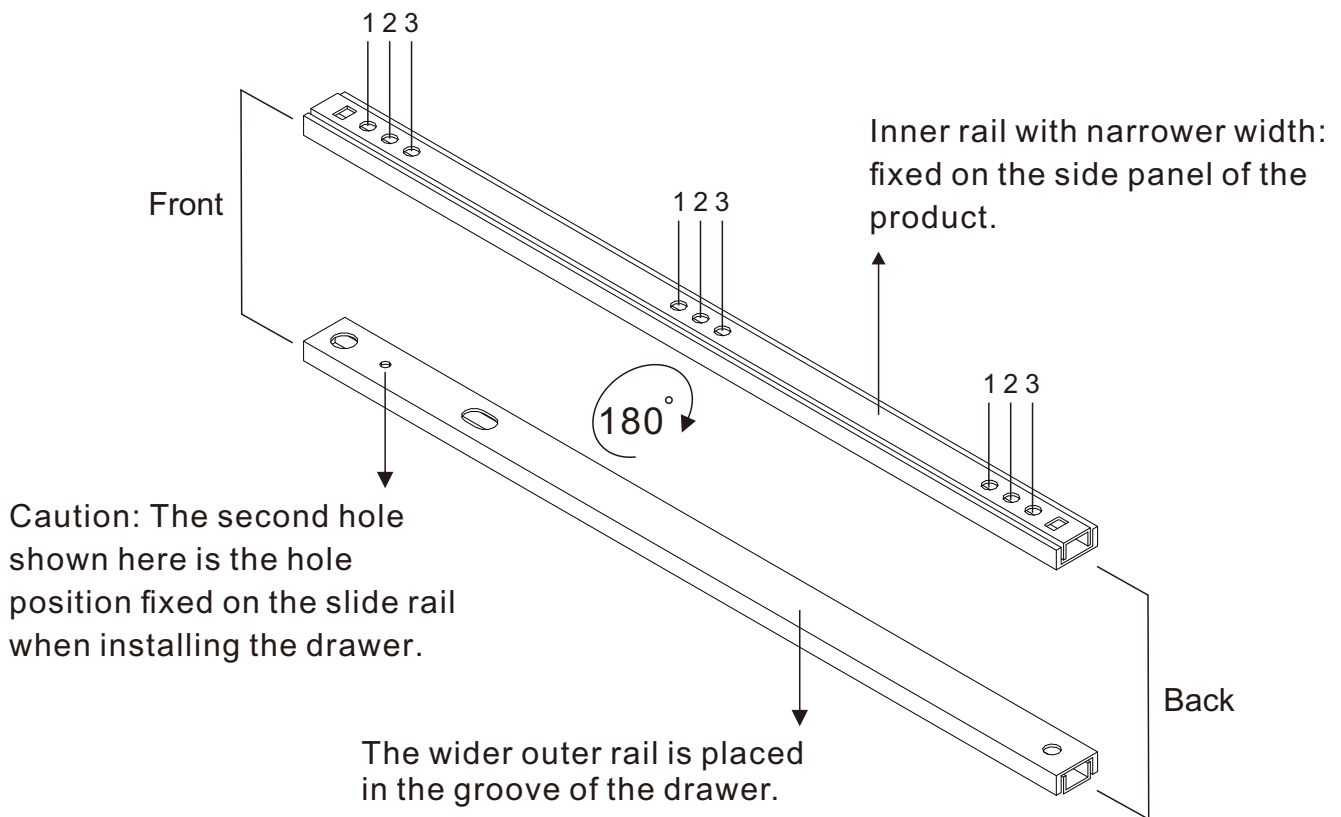

DOWEL

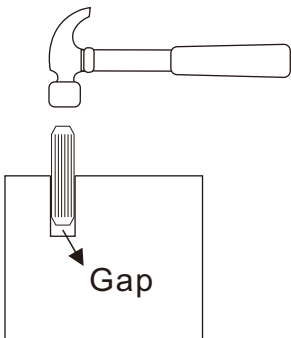

ATTENTION

Inserting wood dowels is likely to be tight, so wood dowels may not easily touch the bottom and damage the side panels during installation. It is recommended to slight hit the wooden pins with a hammer to eliminate the gap between the wood dowel and board.

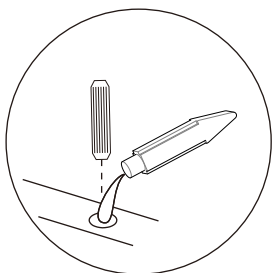

It is recommended to use white glue to increase the safety of the product. If you are worried about assembly errors, you can temporarily not add it, and then add it after confirming.

PARTS LIST

A X1 Top

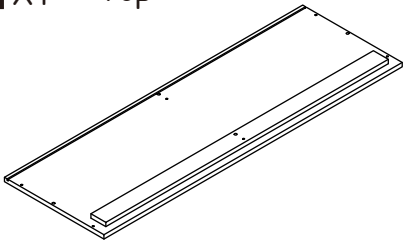

G X2 Top drawer head

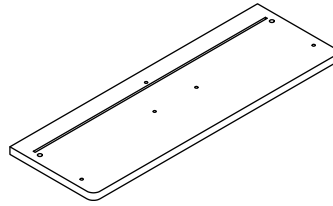

M X6 Drawer support

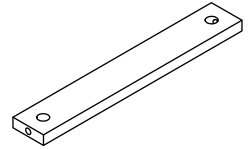

B X1 Bottom

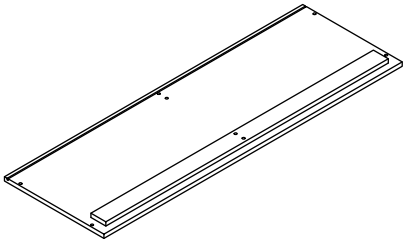

H X2 Middle drawer head

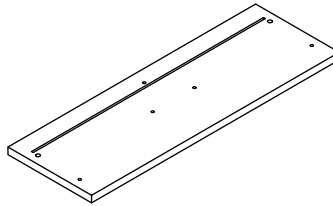

N X6 Drawer bottom

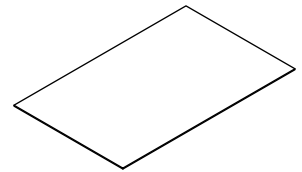

C X1 Left side

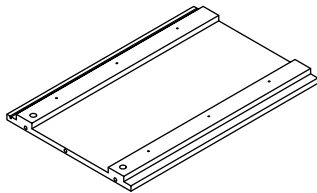

I X2 Bottom drawer head

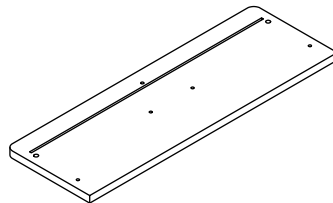

O X2 Back

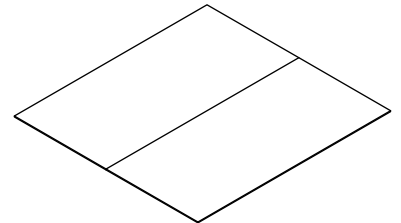

D X1 Right side

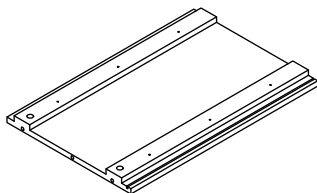

J X6 Drawer left

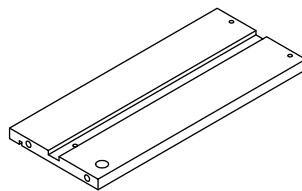

E X1 Front middle

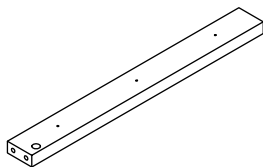

K X6 Drawer right

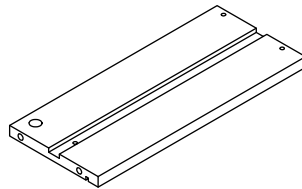

F X1 Back middle

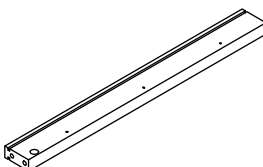

L X6 Drawer back

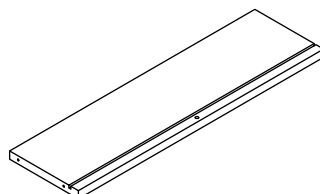

HARDWARE LIST

① X30 Cam bolt 7*35*12.5mm



② X30 Cam lock 15*12mm



③ X18 Dowel 8*30mm



④ X24 Wood screw 8#*1-1/4"



⑤ X6 Coarse screw 7*11*50mm

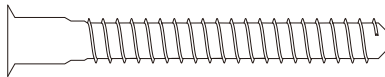

⑥ X12 Slide rail 17*310mm

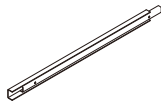

⑦ X24 Wood screw 6#*1/2"

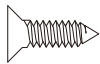

⑧ X12 Fixing screw M4*12mm

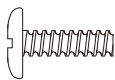

⑨ X6 Handle

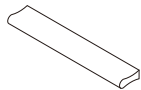

⑩ X12 Handle screw M4*19mm

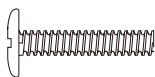

⑪ X5 Foot

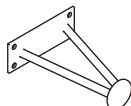

⑫ X5 Foot pad



⑬ X20 T-head screw 4*16mm

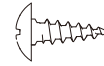

⑭ X8 Fixative plate

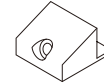

⑮ X8 Wood screw 3*19mm



⑯ X1 Wall mounted strap 25*152mm



⑰ X1 T-head screw 8#*5/8"

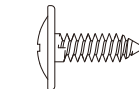

⑱ X1 Wall anchor 1-1/8"

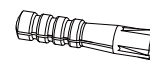

⑲ X1 T-head screw 8#*1"

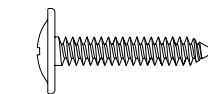

⑳ X1 Allen wrench

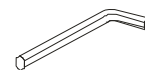

㉑ X1 Glue



Attention

Some number parts listed on the instruction sheet may not be in parts bag as they may already be assembled. Carefully check parts and packing materials prior to ordering replacements.

ASSEMBLY INSTRUCTIONS

Step 1.

1) Front side of slide rail needs to match front shape of the board.

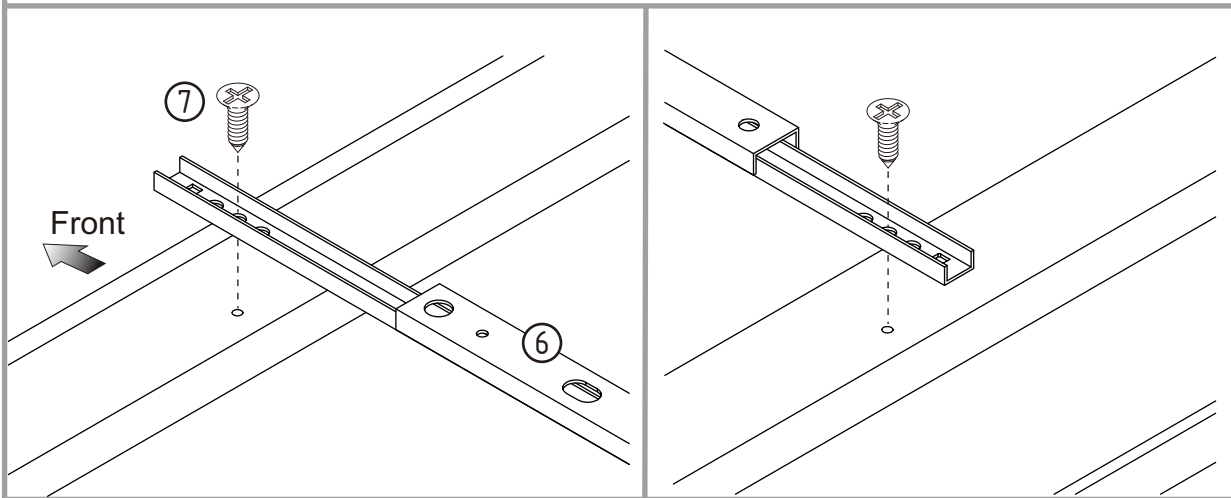

2) Tighten the screws in the second hole in the front and the rear end of the inner rail.

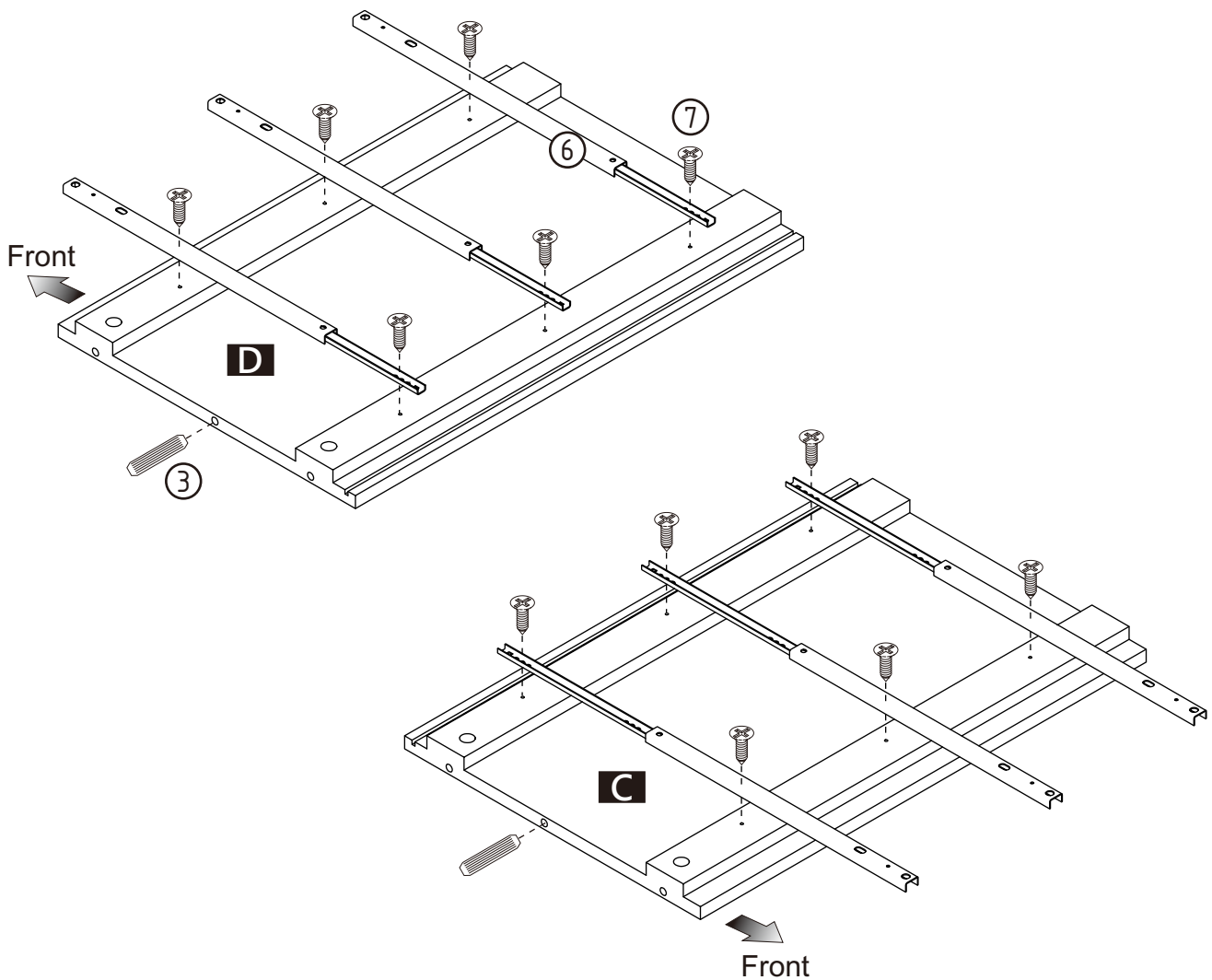

ASSEMBLY INSTRUCTIONS

Step 2.

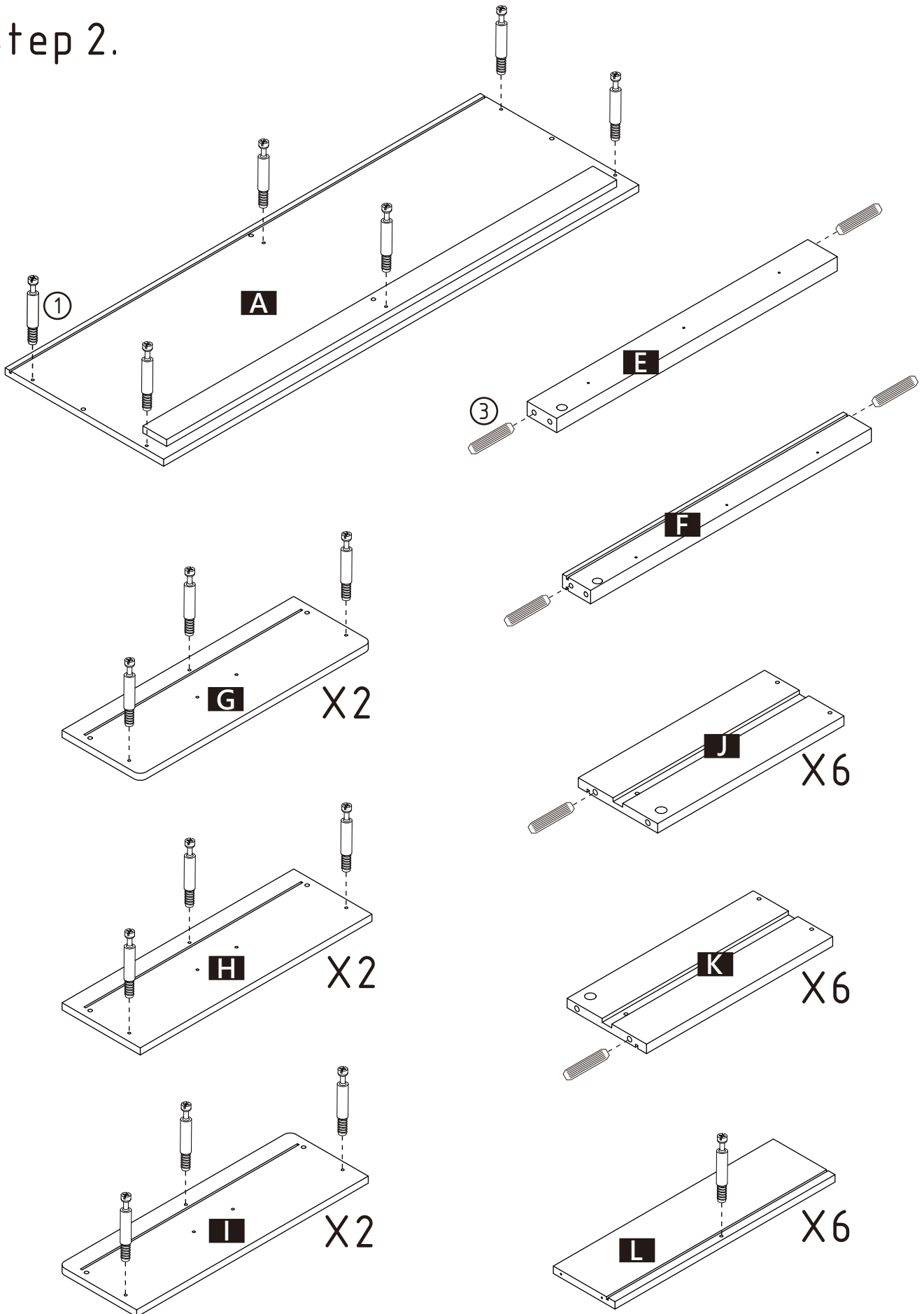

ASSEMBLY INSTRUCTIONS

Step 3.

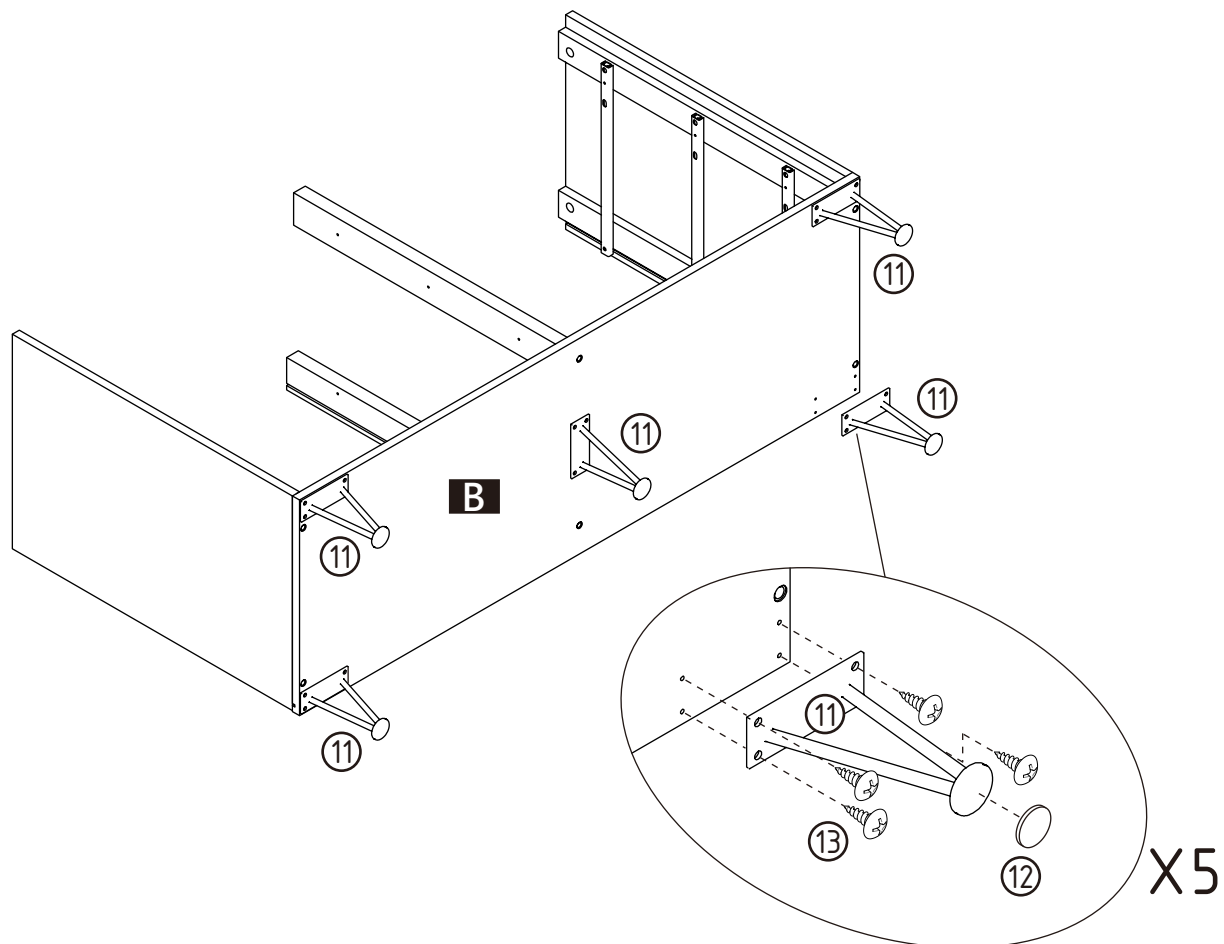
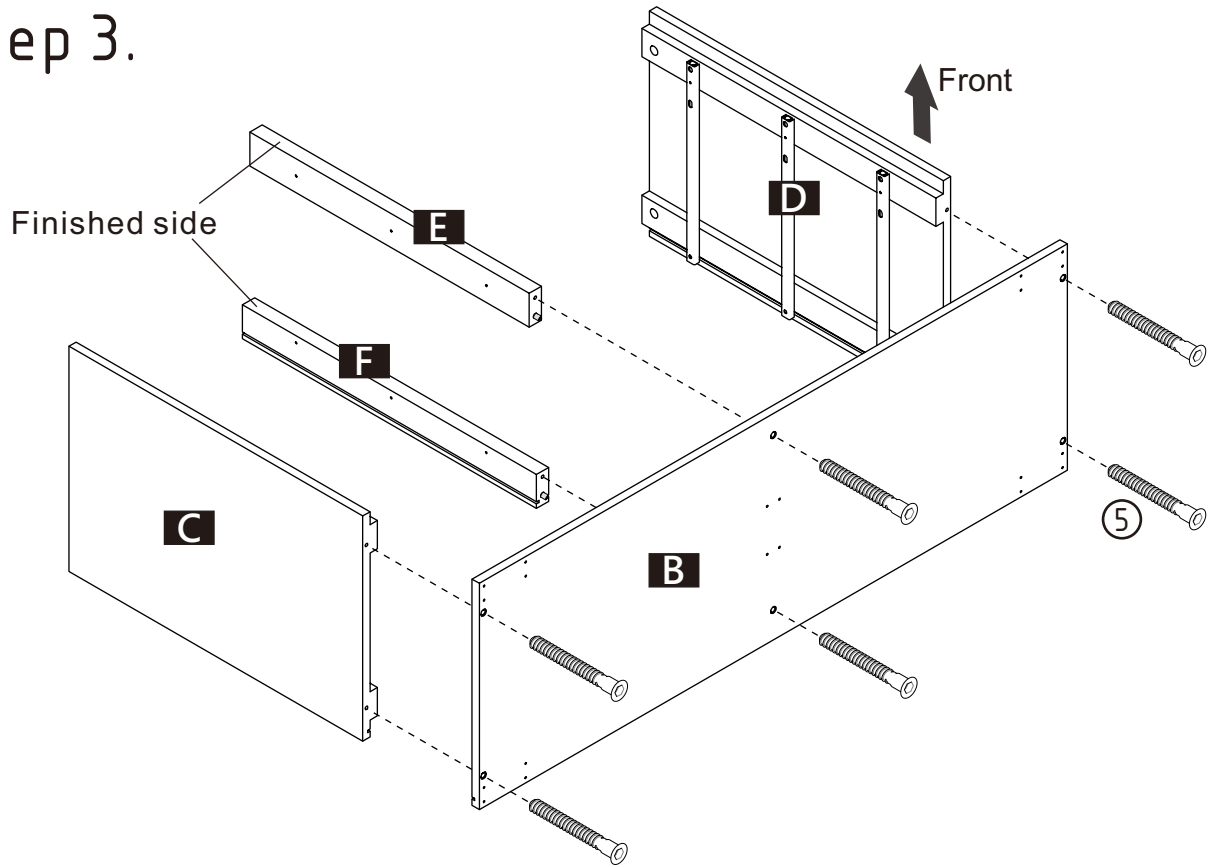

ASSEMBLY INSTRUCTIONS

Step 4.

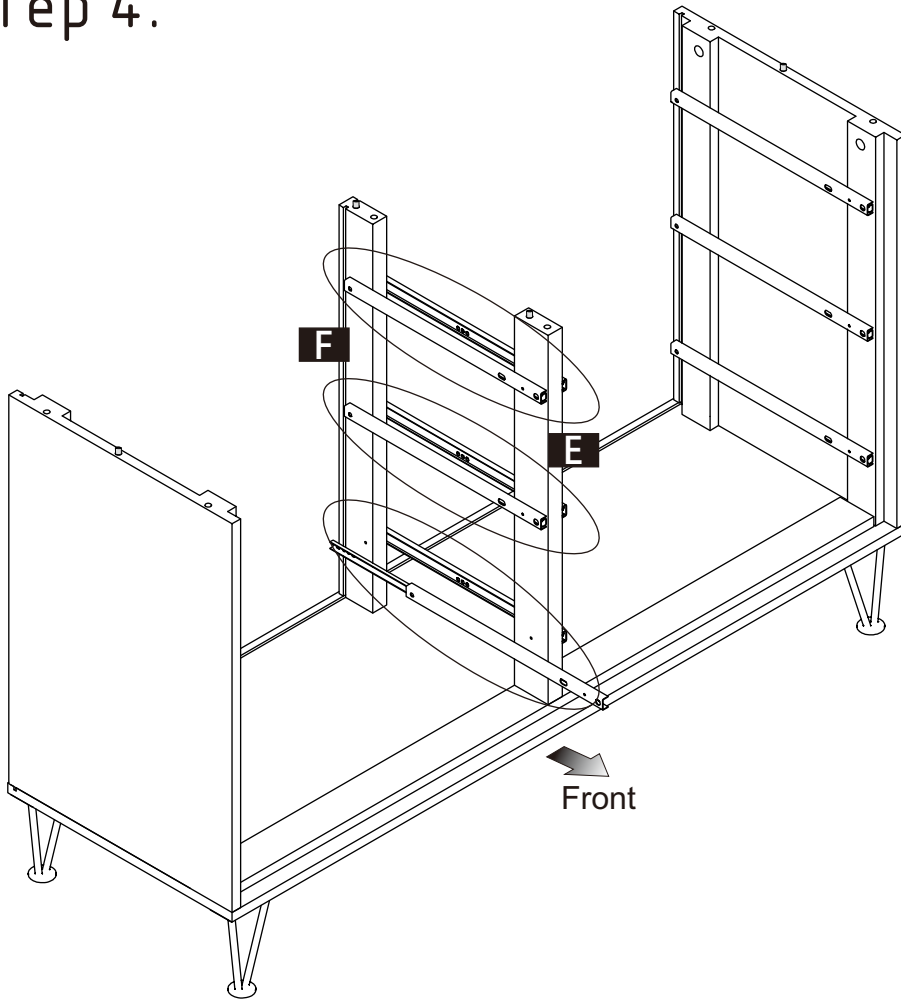

Caution:
Please do not drag or use the corner to lift the product, especially after the cabinet feet are installed. When the product needs to be moved or turned, it must be raised.

1) Front side of slide rail needs to match front shape of the board.

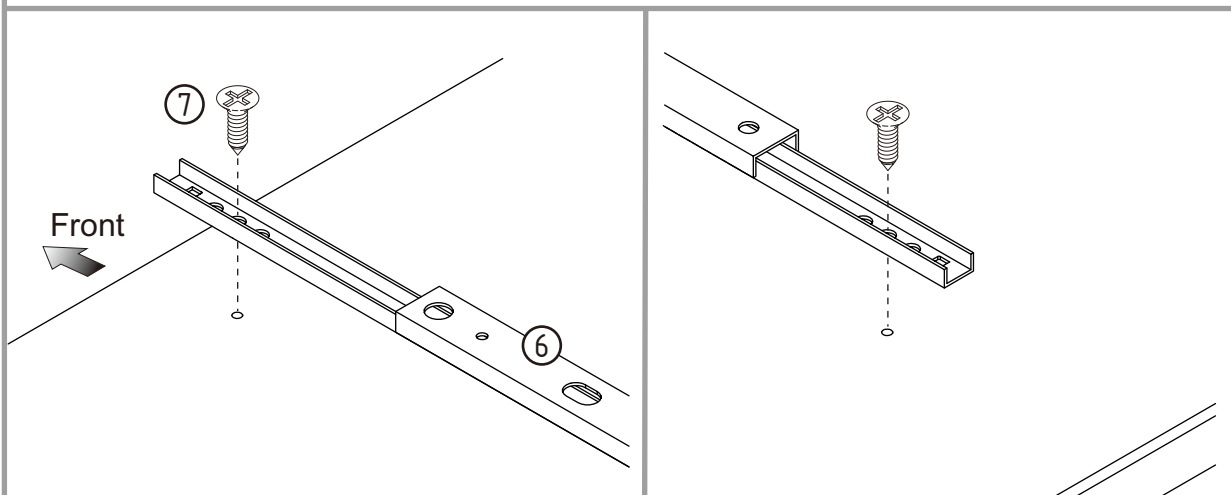

2) Tighten the screws in the second hole in the front and the rear end of the inner rail.

ASSEMBLY INSTRUCTIONS

Step 5.

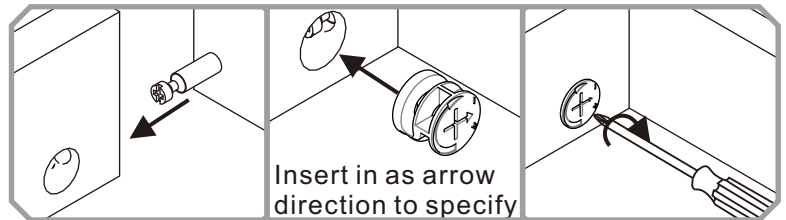
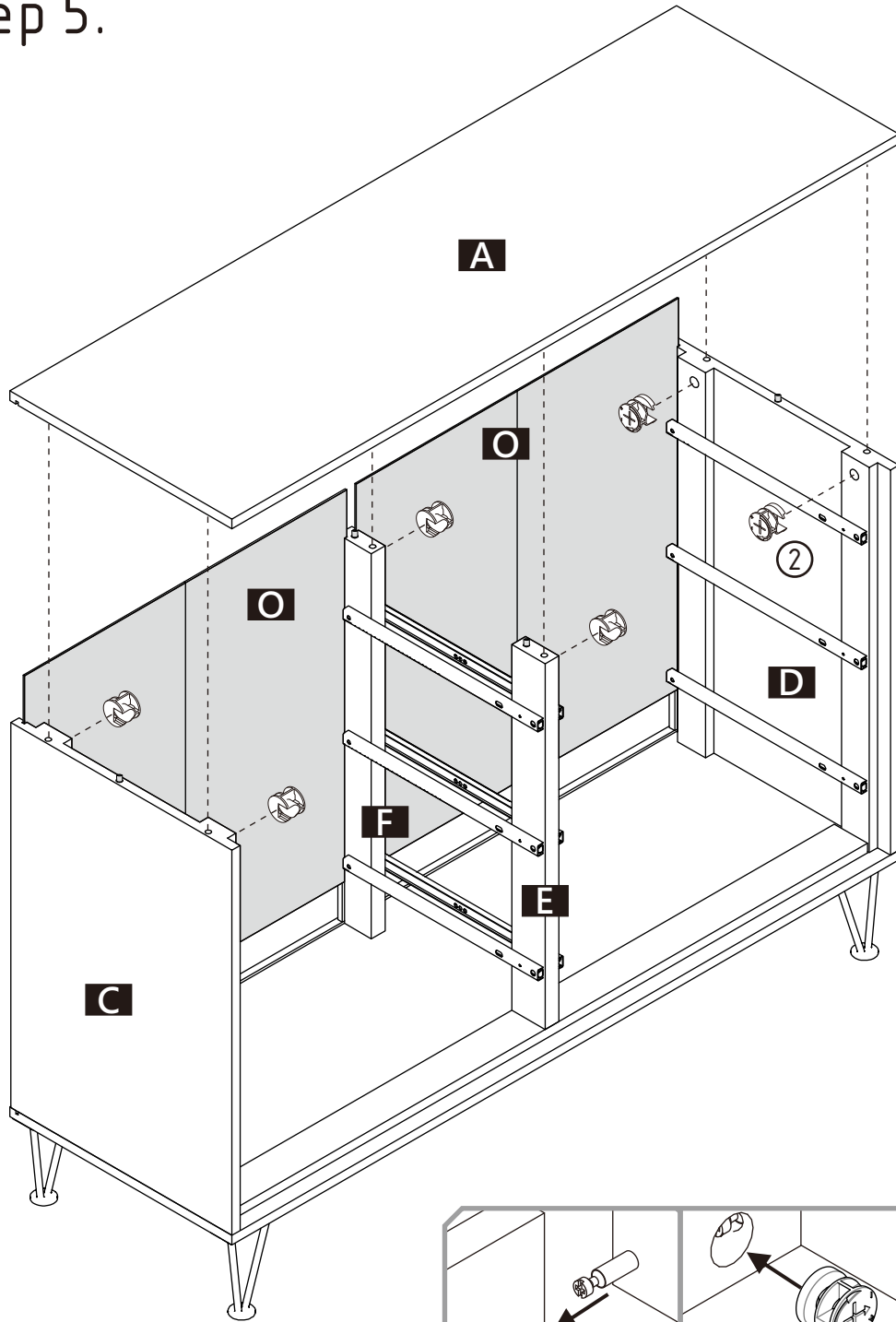

ASSEMBLY INSTRUCTIONS

Step 6.

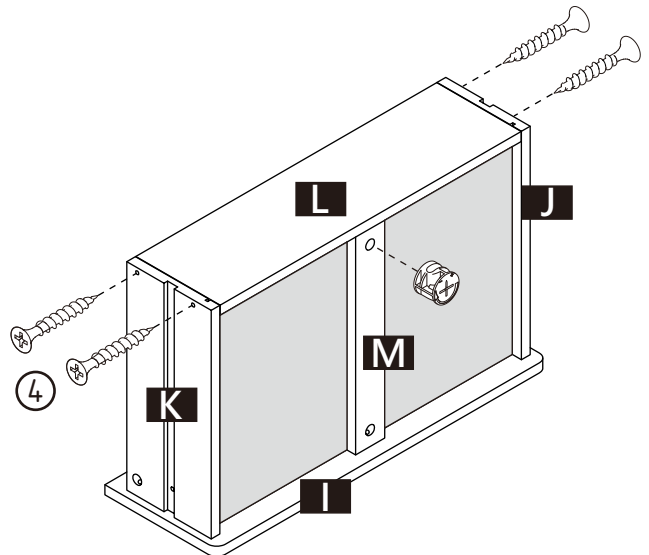
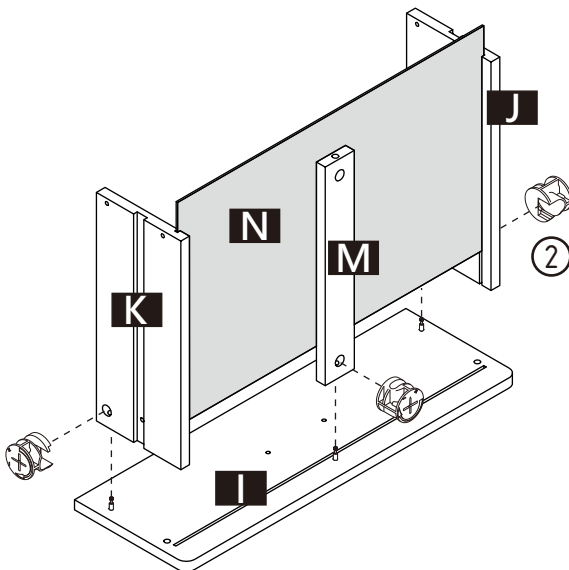
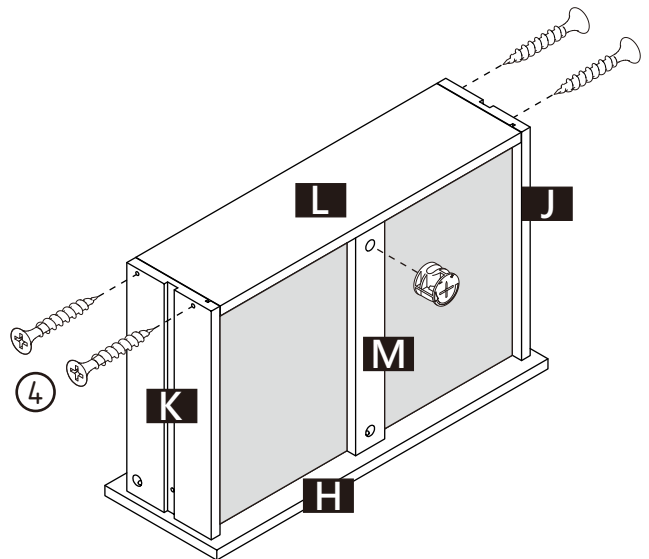
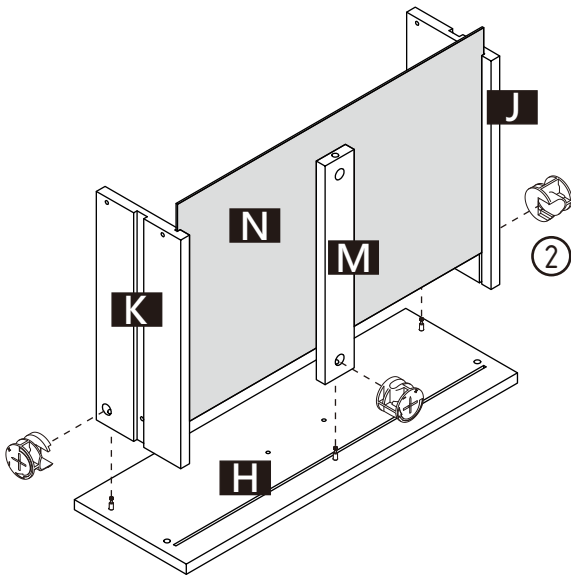
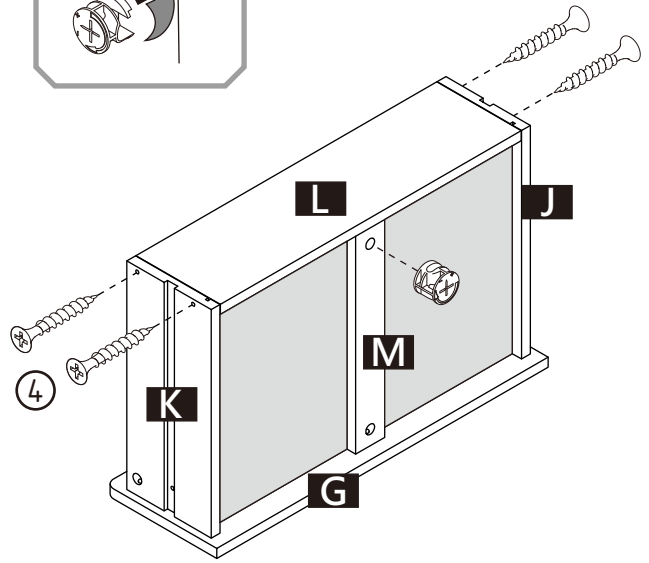
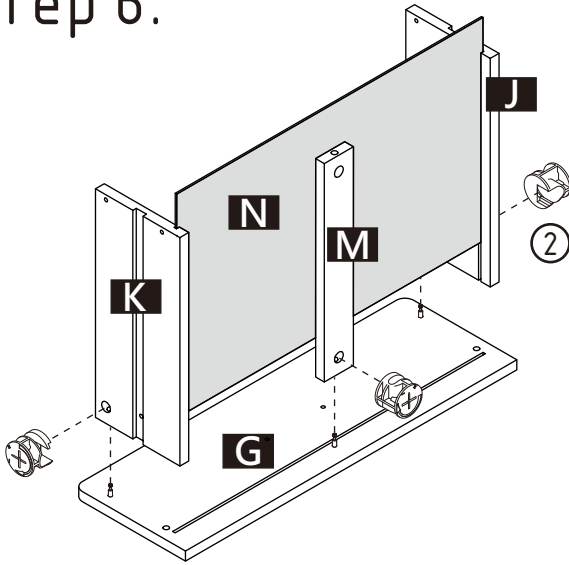
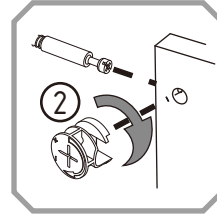

ASSEMBLY INSTRUCTIONS

Step 7.

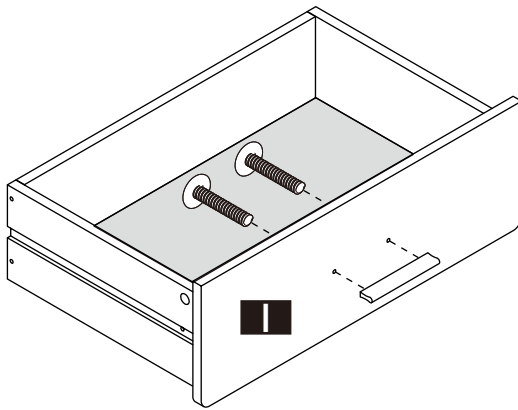
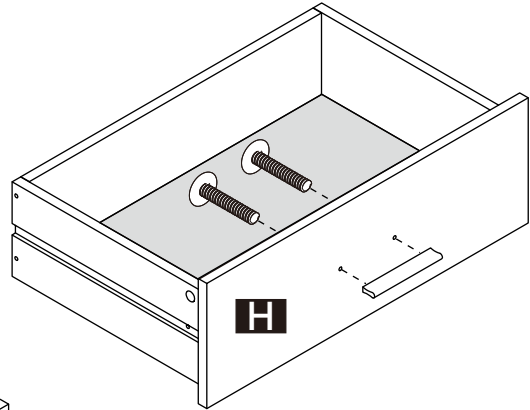
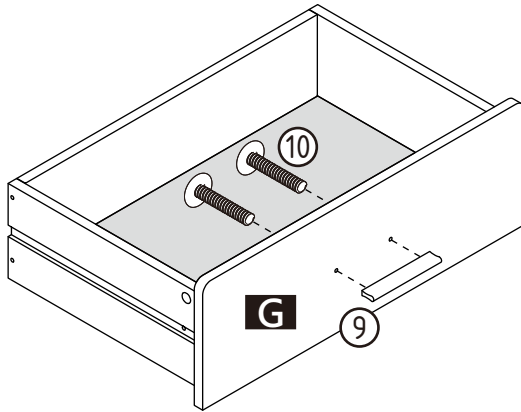

Step 8.

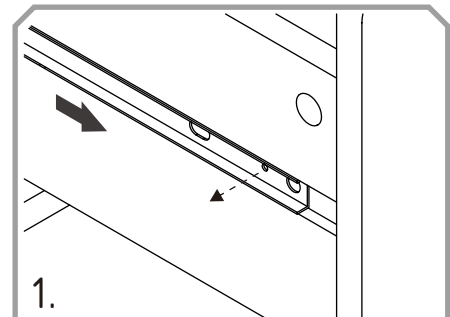
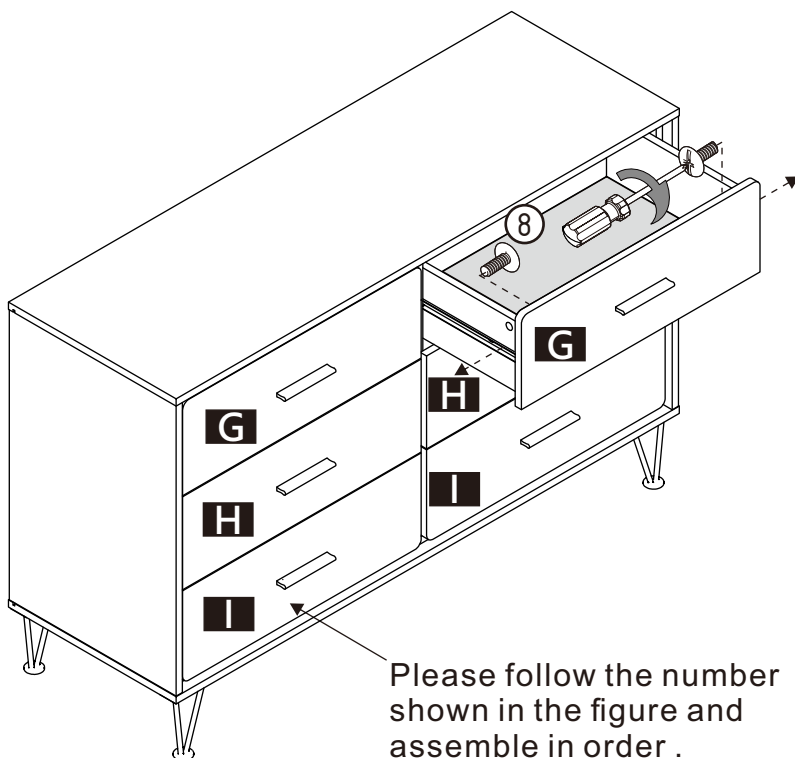

Extend the two outer slides of the runners so that they could align with the sides of the drawer. Make sure the pre-drilled holes from the drawer align with the screw holes of the outer slides.

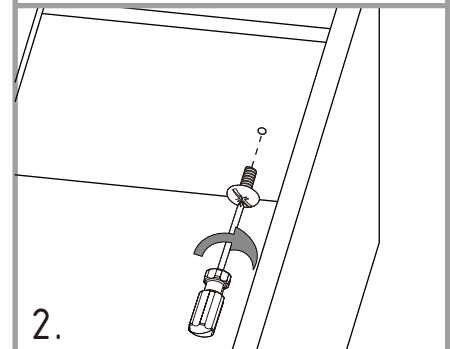

Secure two screws from the inside of the drawer using a Phillips screwdriver to tighten them to the outer slides.

ASSEMBLY INSTRUCTIONS

Step 9.

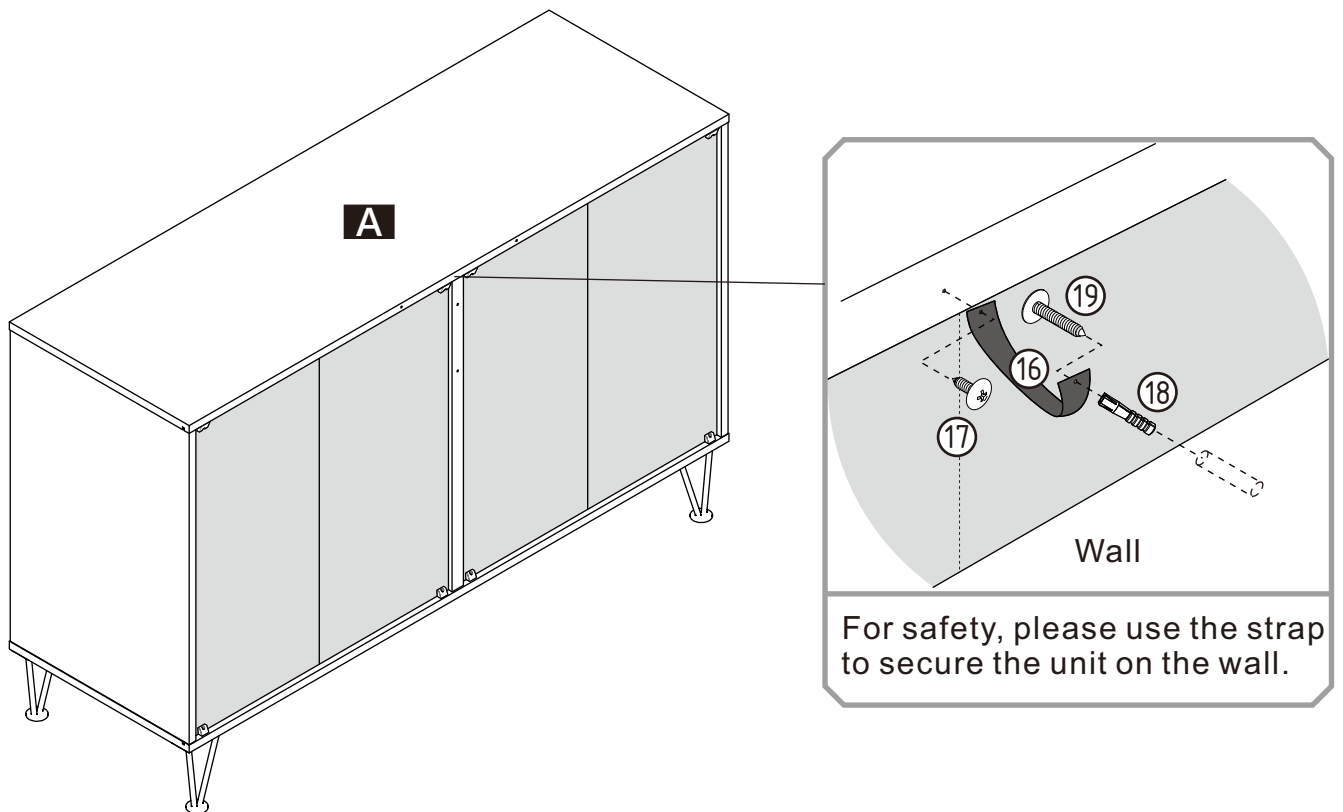
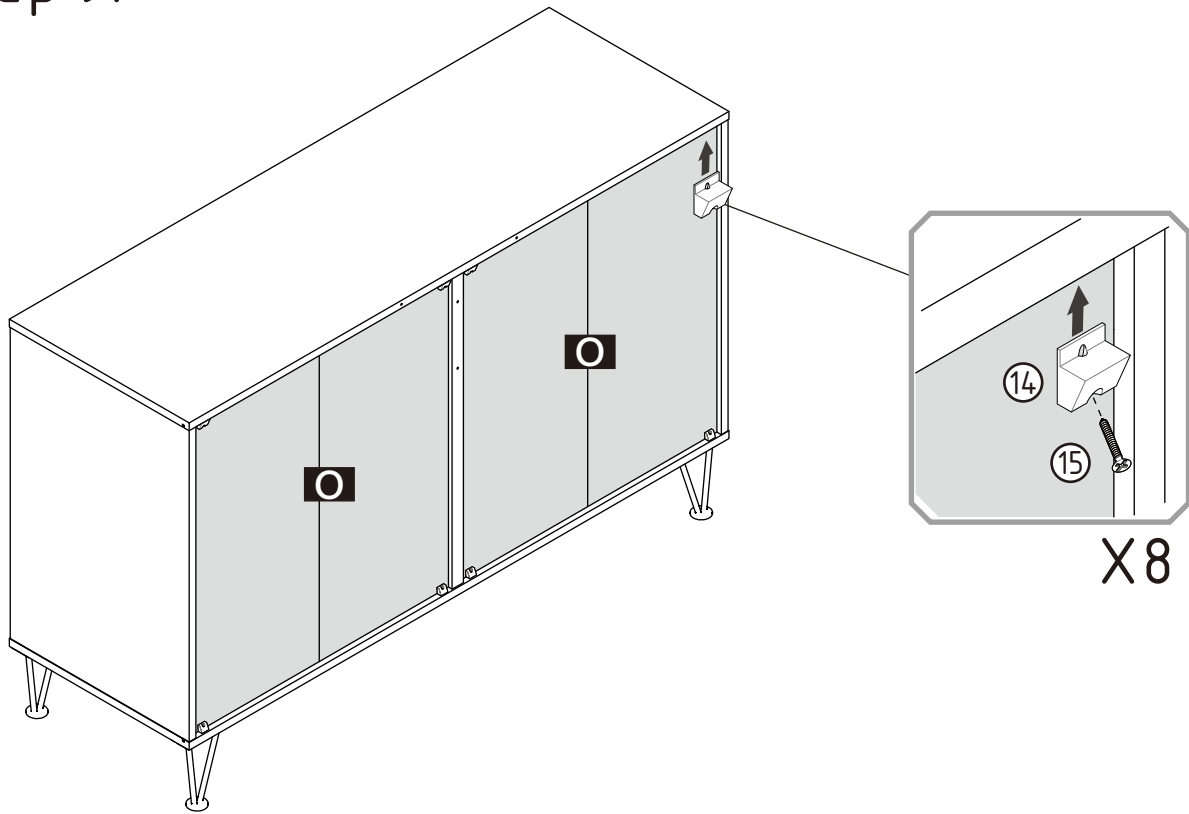

ASSEMBLY IS COMPLETED.

Make sure the product is rested on a flat surface and does not feel loose or wobbly. If it does, double check that the bolts/screws are secured and properly tightened.