

Installation & Assembly

Do not tighten screws until completely assembled

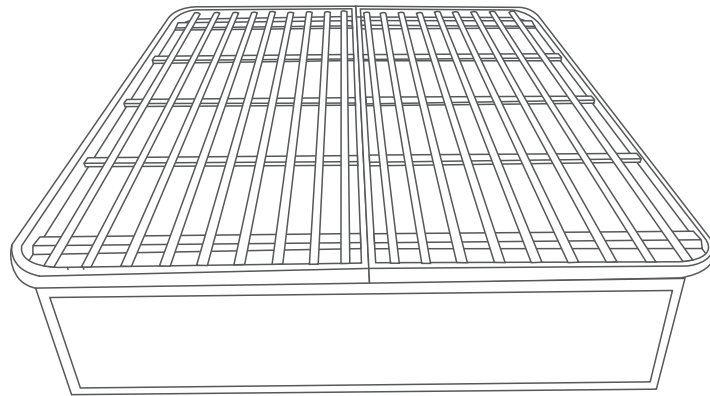

PARTS LIST/

A		2
B		2
C		2
D		9

①		M6X30 BOLT	26
②		M6X55 BOLT	12
③		Flat Washer	26
④		Spring Washer	38
⑤		Curved Washer	12
⑥		M4	1

STEP 1

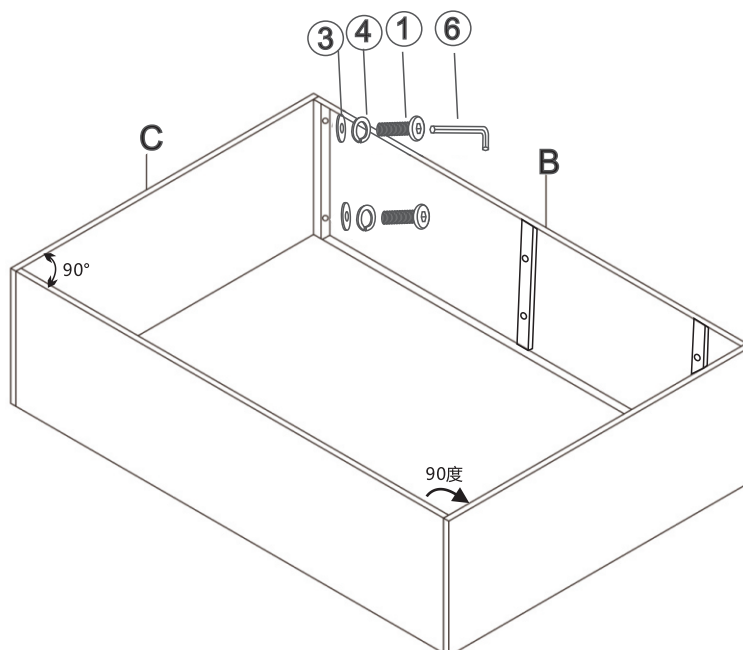

STEP 2

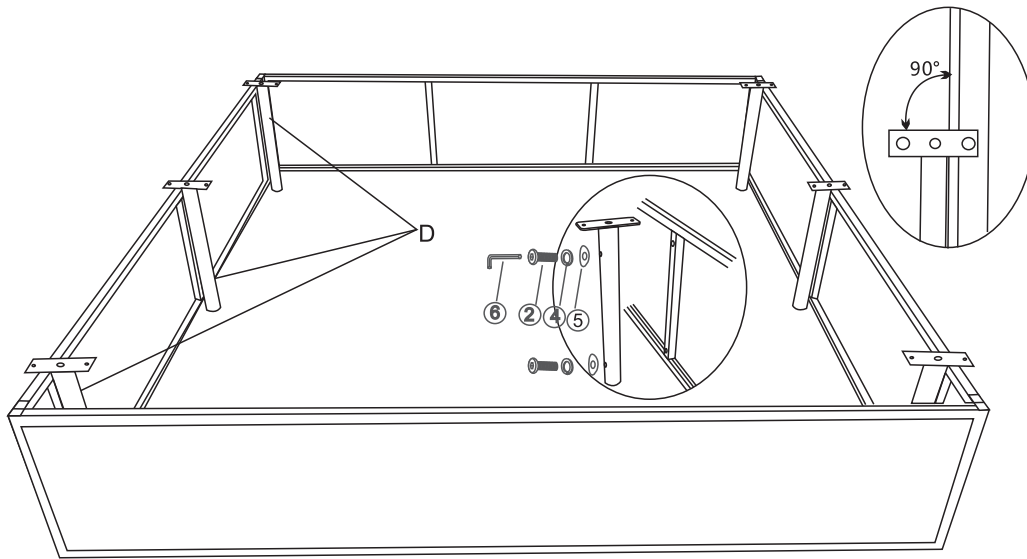

STEP 3

Push left and right bed sides to make sure the screw holes on the parts(D) are aligned with the screw holes on the Slat(A). Screw in all necessary hardware as shown only halfway.

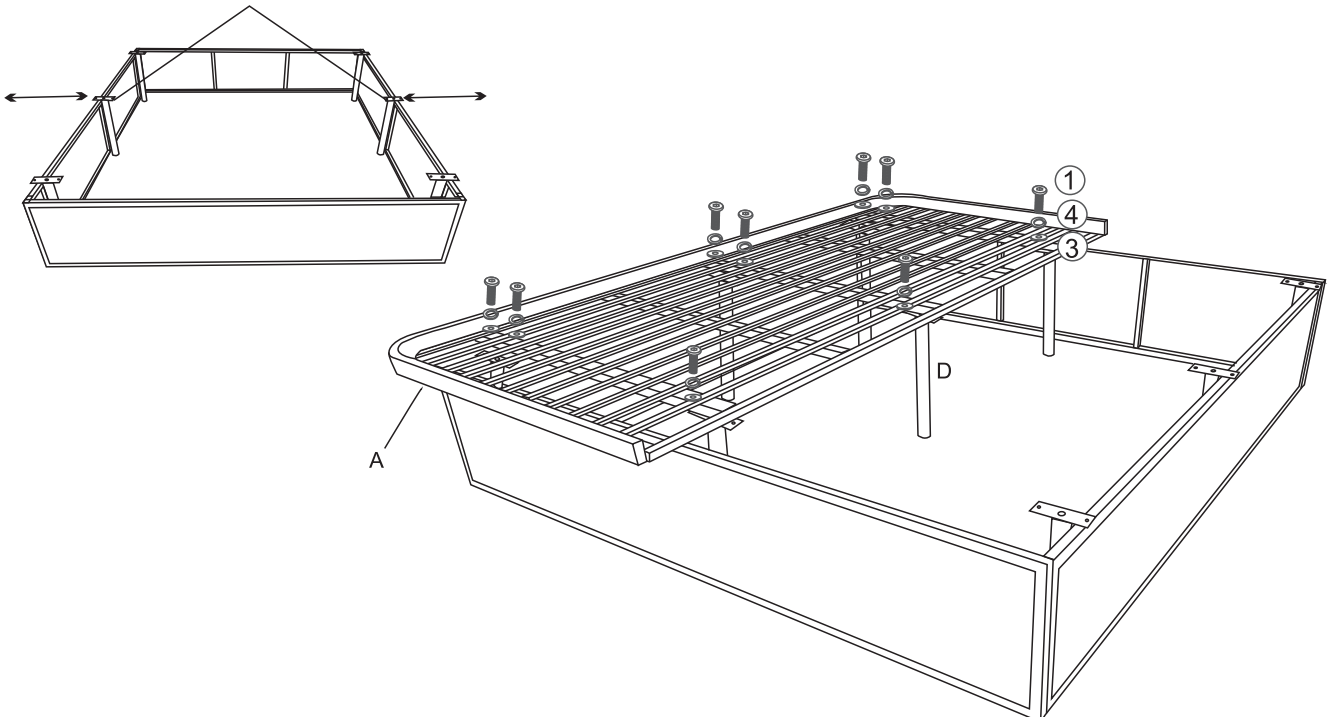

STEP 4

Push left and right bed sides to make sure the screw holes on the parts(D) are aligned with the screw holes on the Slat(A). Screw in all necessary hardware as shown only halfway.

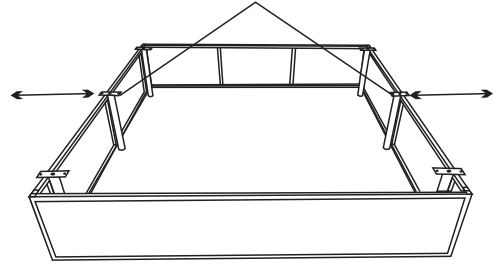
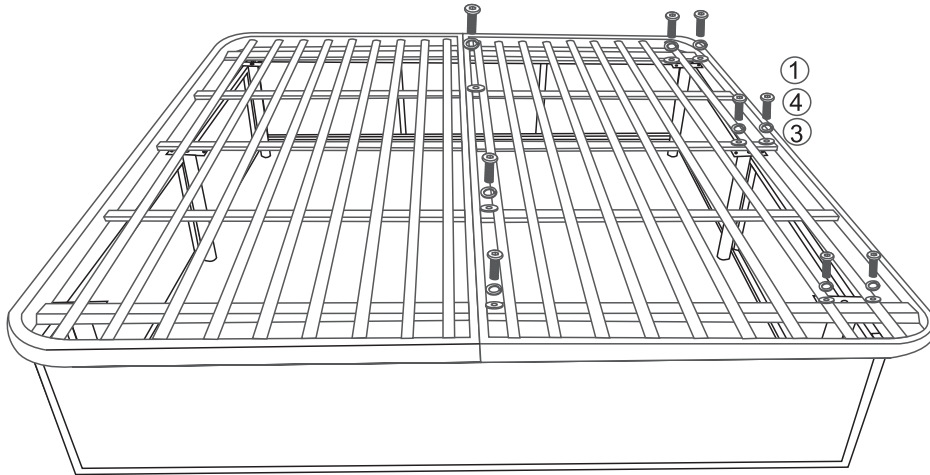

STEP 5

