

ASSEMBLY INSTRUCTIONS
COASTER FINE FURNITURE

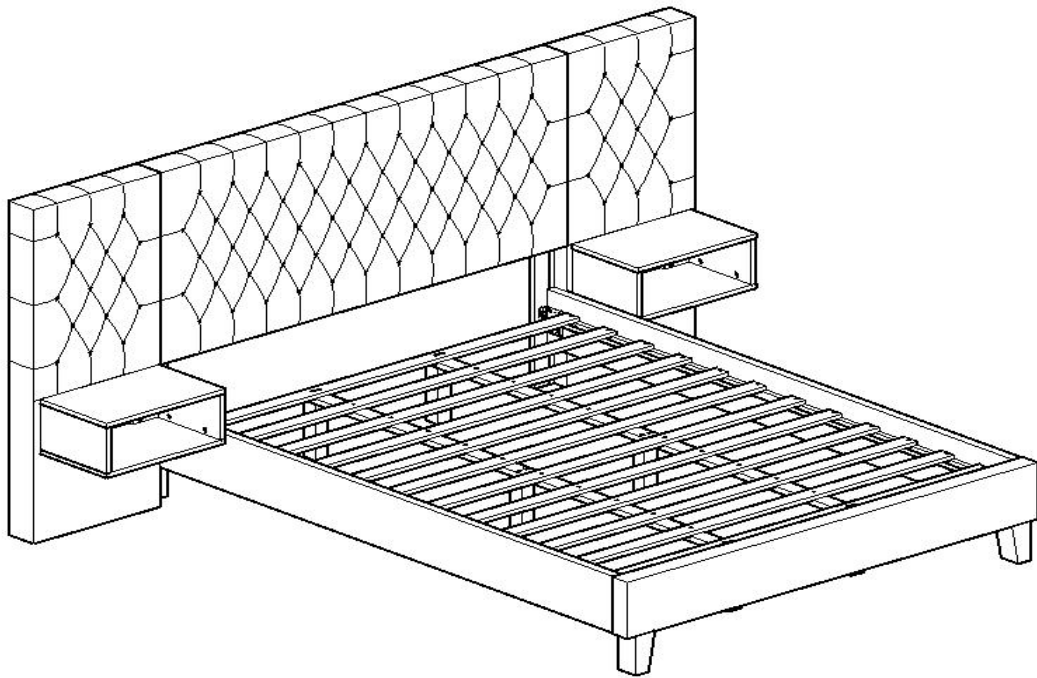

Fine Furniture for every stage of life

300833KE(B1-B3)
Eastern King Bed

ITEM: 300833KE(B1-B3)



ASSEMBLY INSTRUCTIONS

ASSEMBLY TIPS:

1. Remove hardware from box and sort by size.
2. Please check to see that all hardware and parts are present prior to start of assembly.
3. Please follow attached instructions in the same sequence as numbered to assure fast & easy assembly.



WARNING!

1. Don't attempt to repair or modify parts that are broken or defective. Please contact the store immediately.
2. This product is for home use only and not intended for commercial establishments.



ASSEMBLY TIME

35 MINUTES

PARTS IDENTIFICATION

B1 (BOX 1)

A	HEADBOARD PANEL		1PC
B	LEFT HEADBOARD LEG		1PC
C	RIGHT HEADBOARD LEG		1PC

D	CENTER RAIL SUPPORT WITH LEVELER		6PCS
E	FOOTBOARD LEG		2PCS

B2 (BOX 2)

F	LEFT PANEL		1PC
G	RIGHT PANEL		1PC
H	NIGHTSTAND TOP & BOTTOM PANEL		4PCS

I	NIGHTSTAND SIDE PANEL		4PCS
J	NIGHTSTAND BACK PANEL		4PCS

B3 (BOX 3)

K	BED RAIL		2PCS
L	FOOTBOARD PANEL		1PC
M	CENTER RAIL		2PCS
N	ROLL SLAT (6PCS)		2SETS

ITEM:300833KE(B1-B3)



ASSEMBLY INSTRUCTIONS

ASSEMBLY TIPS:

1. Remove hardware from box and sort by size.
2. Please check to see that all hardware and parts are present prior to start of assembly.
3. Please follow attached instructions in the same sequence as numbered to assure fast & easy assembly.

















WARNING!

1. Don't attempt to repair or modify parts that are broken or defective. Please contact the store immediately.
2. This product is for home use only and not intended for commercial establishments.

HARDWARE IDENTIFICATION

Z-B1 (BOX 1) - HARDWARE PACK IS LOCATED IN 300833KE (B1)

1	SMALL ALLEN WRENCH (M4 x 55mm - BLK)		1PC	9	FLAT WASHER (M6 - RBW)		18PCS
2	BIG ALLEN WRENCH (M5 x 100mm - BLK)		1PC	10	FLAT HEAD SCREW (M4 x 25mm - RBW)		44PCS
3	BOLT 1 (M8 x 80mm - RBW)		2PCS	11	WOOD DOWEL (M8 x 25mm - NATURAL)		32PCS
4	BOLT 2 (M6 x 35mm - RBW)		12PCS	12	CAM NUT		28PCS
5	BOLT 3 (M6 x 40mm - RBW)		10PCS	13	CAM BOLT		28PCS
6	BOLT 4 (M6 x 60mm - RBW)		8PCS	14	DECORATIVE STICKER		36PCS
7	BOLT 5 (M6 x 50mm - RBW)		8PCS				
8	LOCK WASHER (M6 - RBW)		18PCS				

NOTE:

Phillips head screw driver is required in the assembly process; however, manufacturer does not provide this item.

ASSEMBLY INSTRUCTIONS

STEP 1

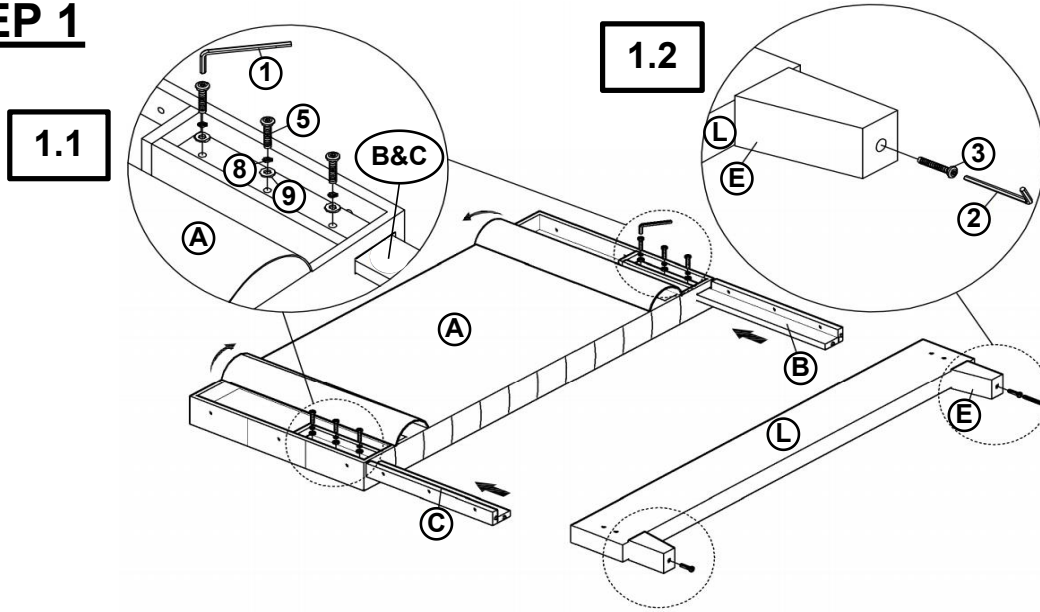

STEP 2

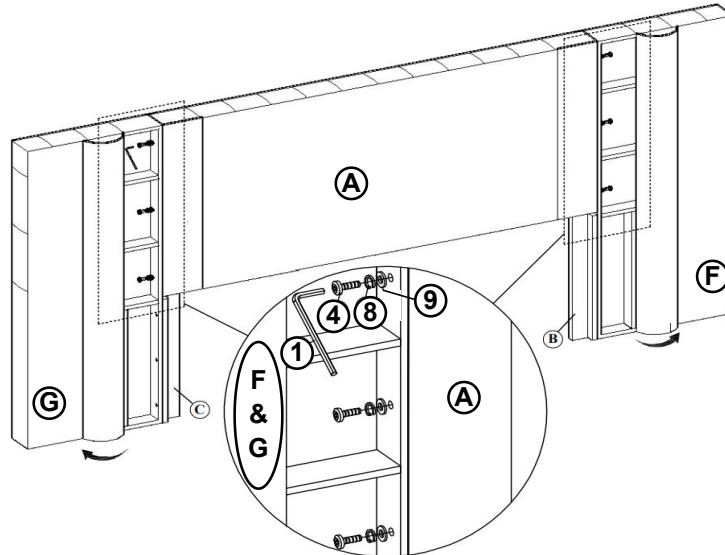

STEP 3

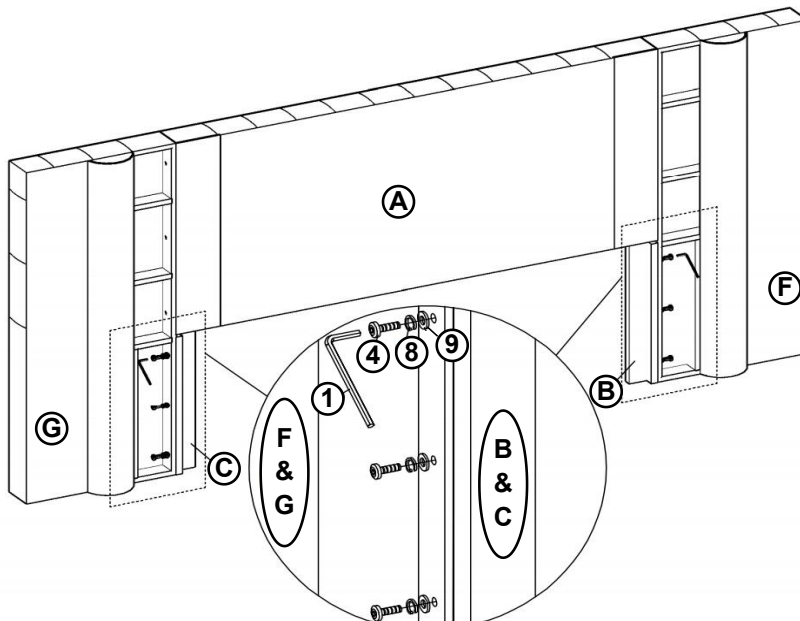

ITEM: **300833KE(B1-B3)**



ASSEMBLY INSTRUCTIONS

STEP 4

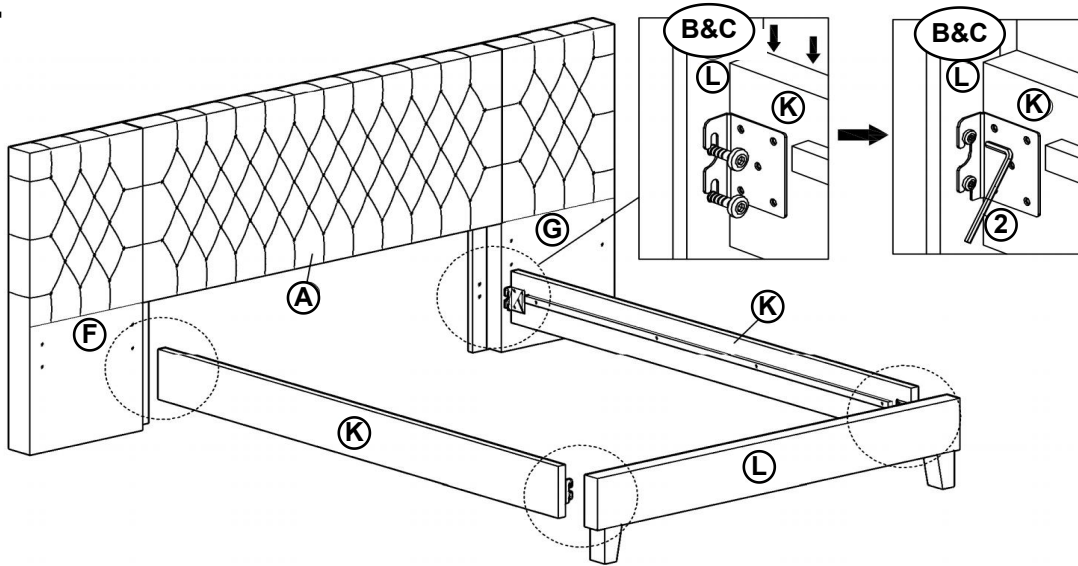

STEP 5

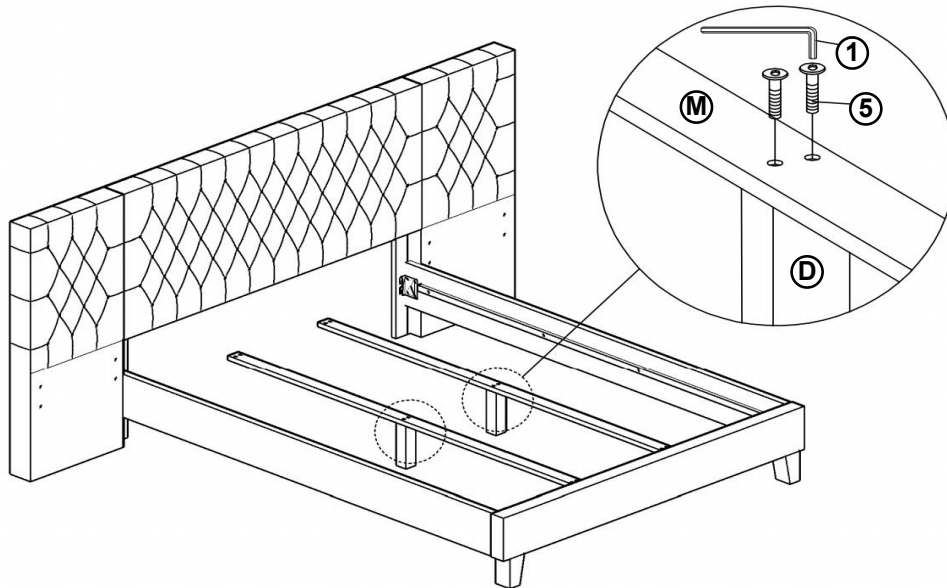

STEP 6

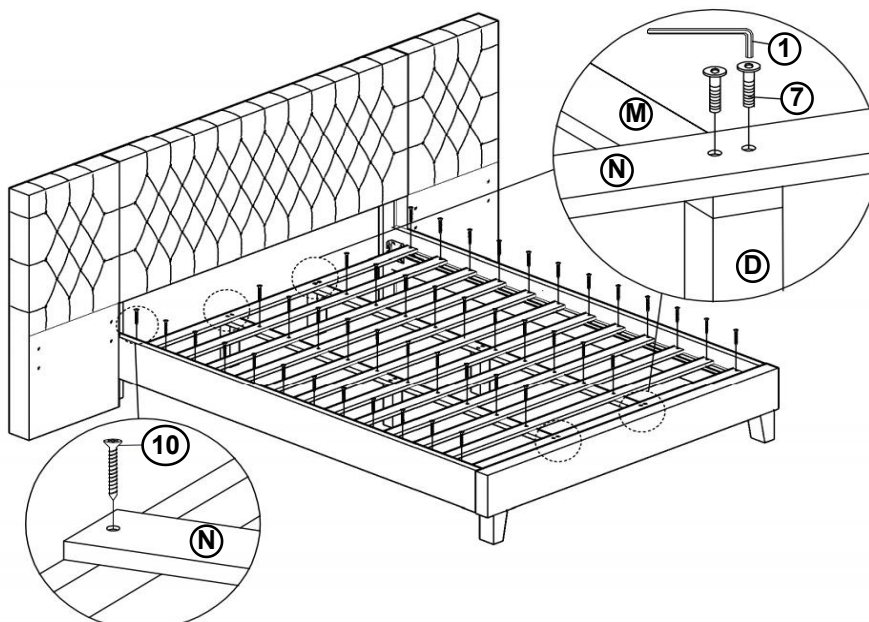

ASSEMBLY INSTRUCTIONS

STEP 7

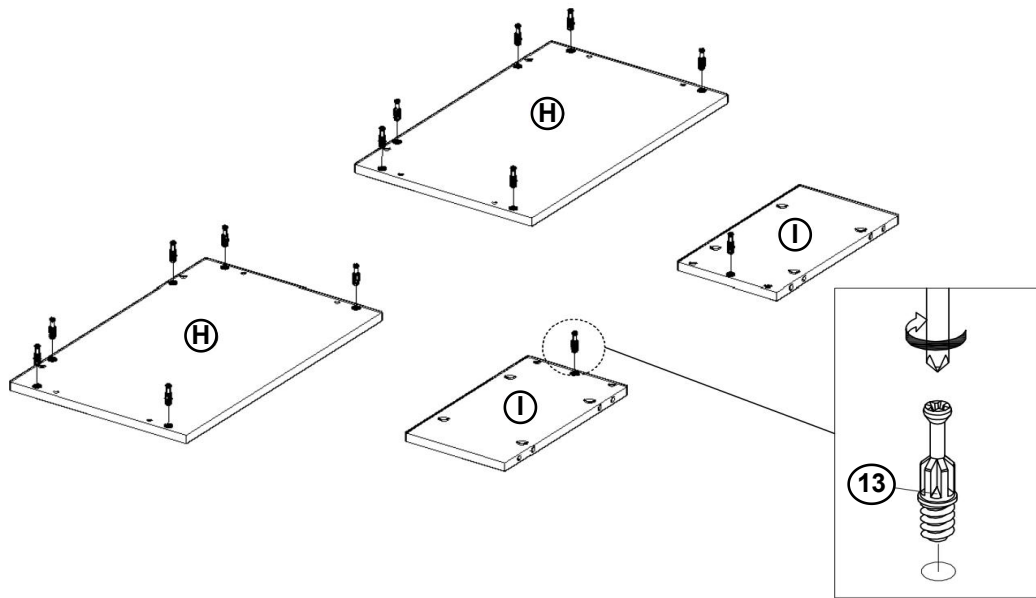

STEP 8

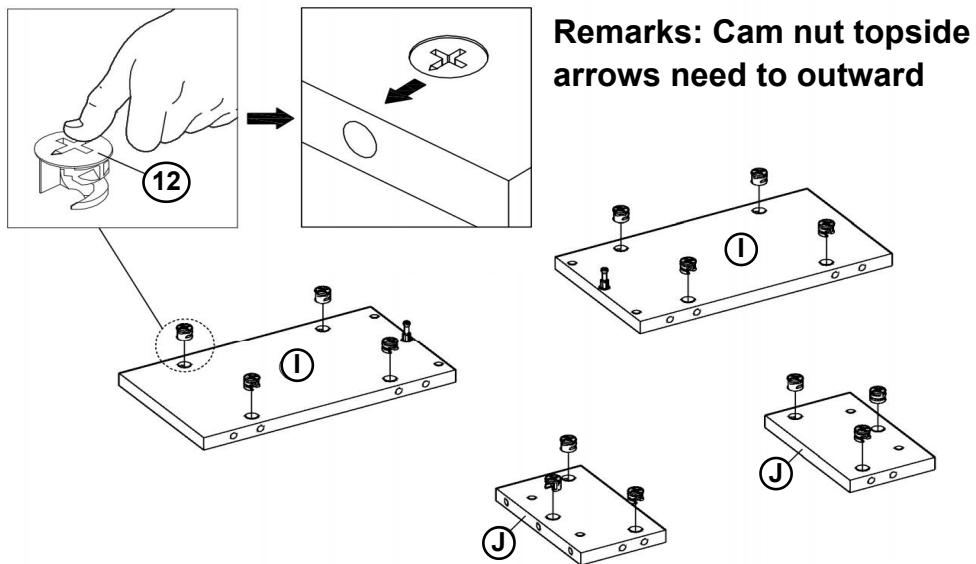

STEP 9

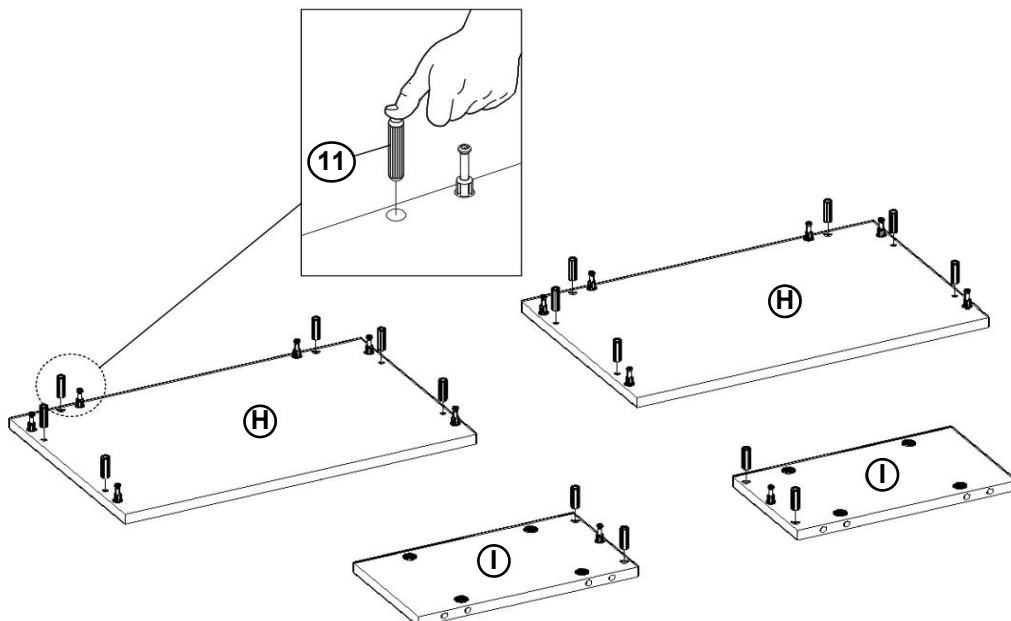

ASSEMBLY INSTRUCTIONS

STEP 10

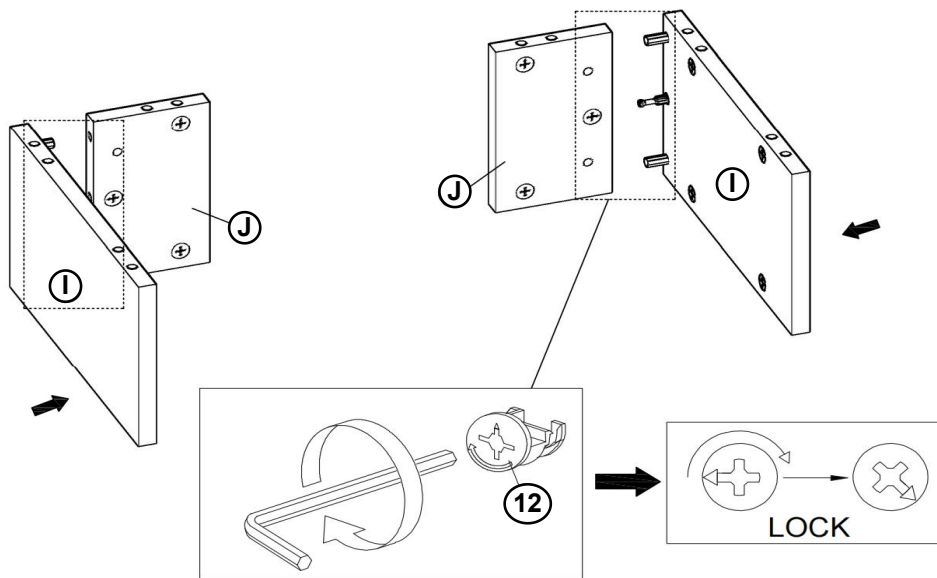

STEP 11

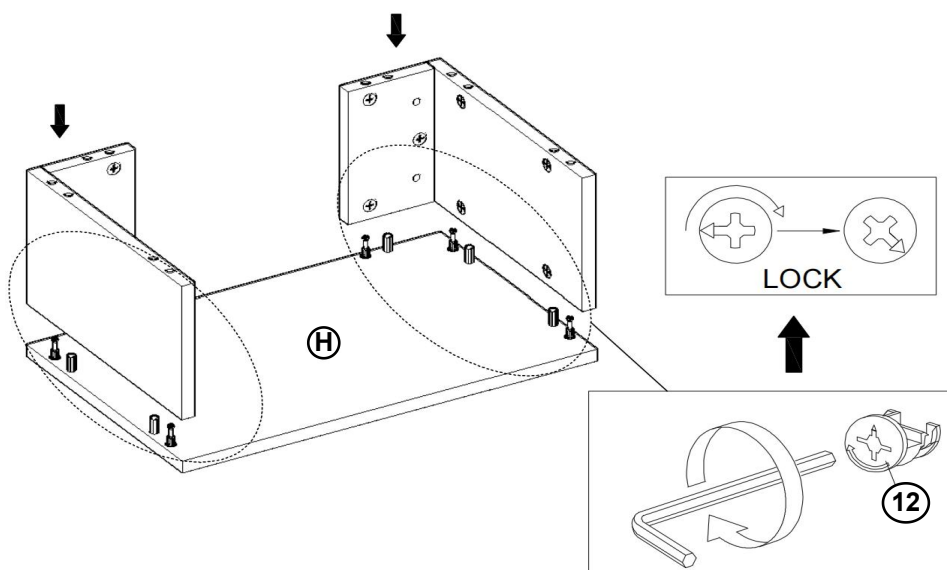

STEP 12

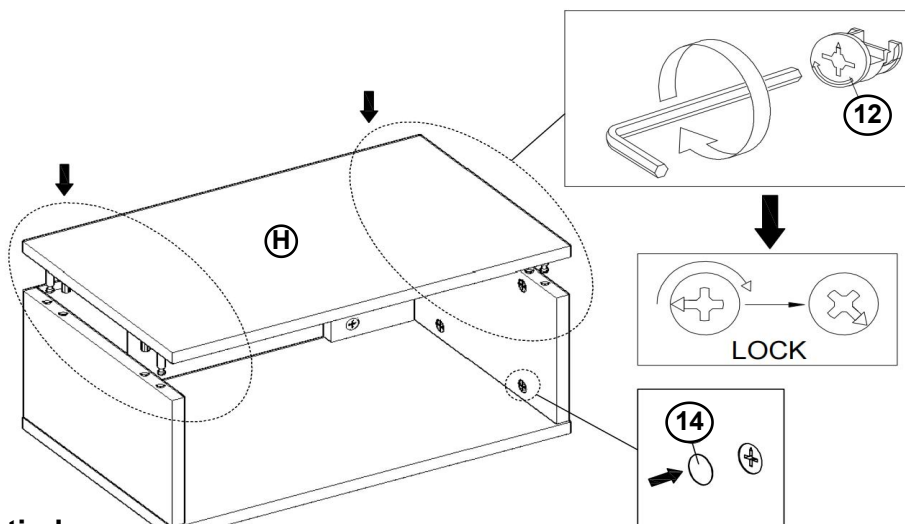

Remarks: After tied up the cam bolt need to paste the sticker

ITEM: **300833KE(B1-B3)**



ASSEMBLY INSTRUCTIONS

STEP 13

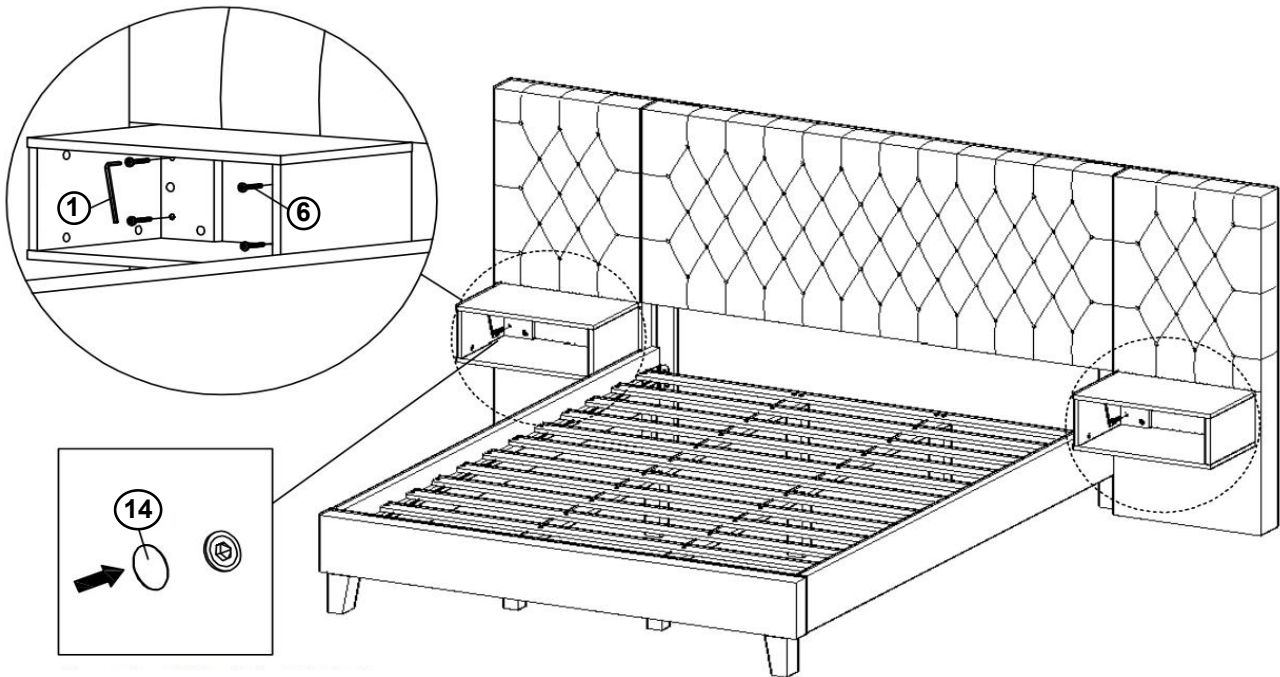

Remarks: After tied up the bolts need to paste the sticker

STEP 14
COMPLETE

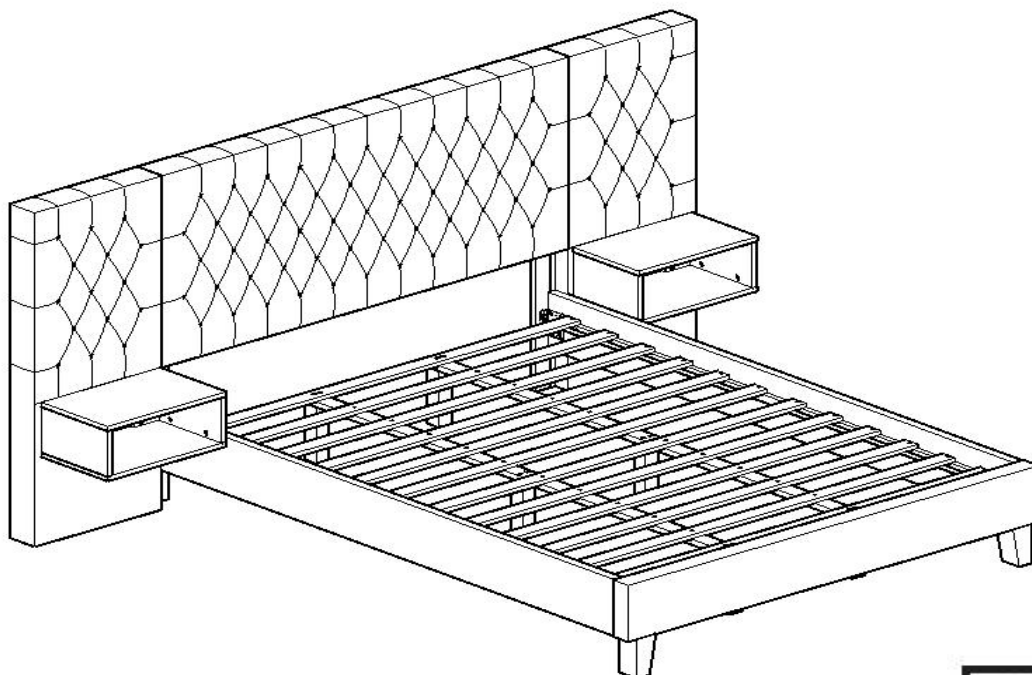

ITEM:300833KE(B1-B3)



Inner Size : 76.75"W X 81.25"D

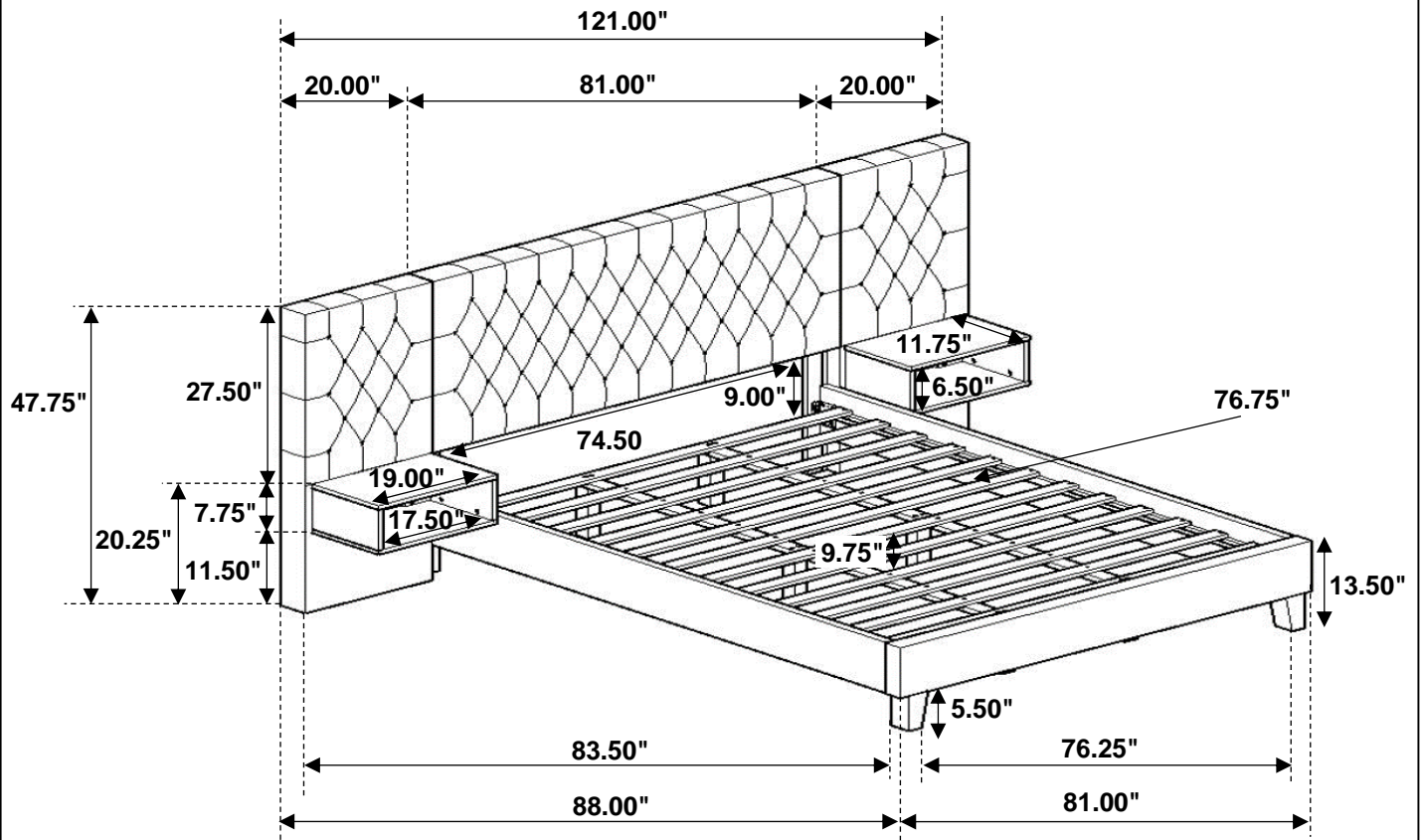

Note : Dimension tolerance $\pm 5\%$