

Installation Instruction

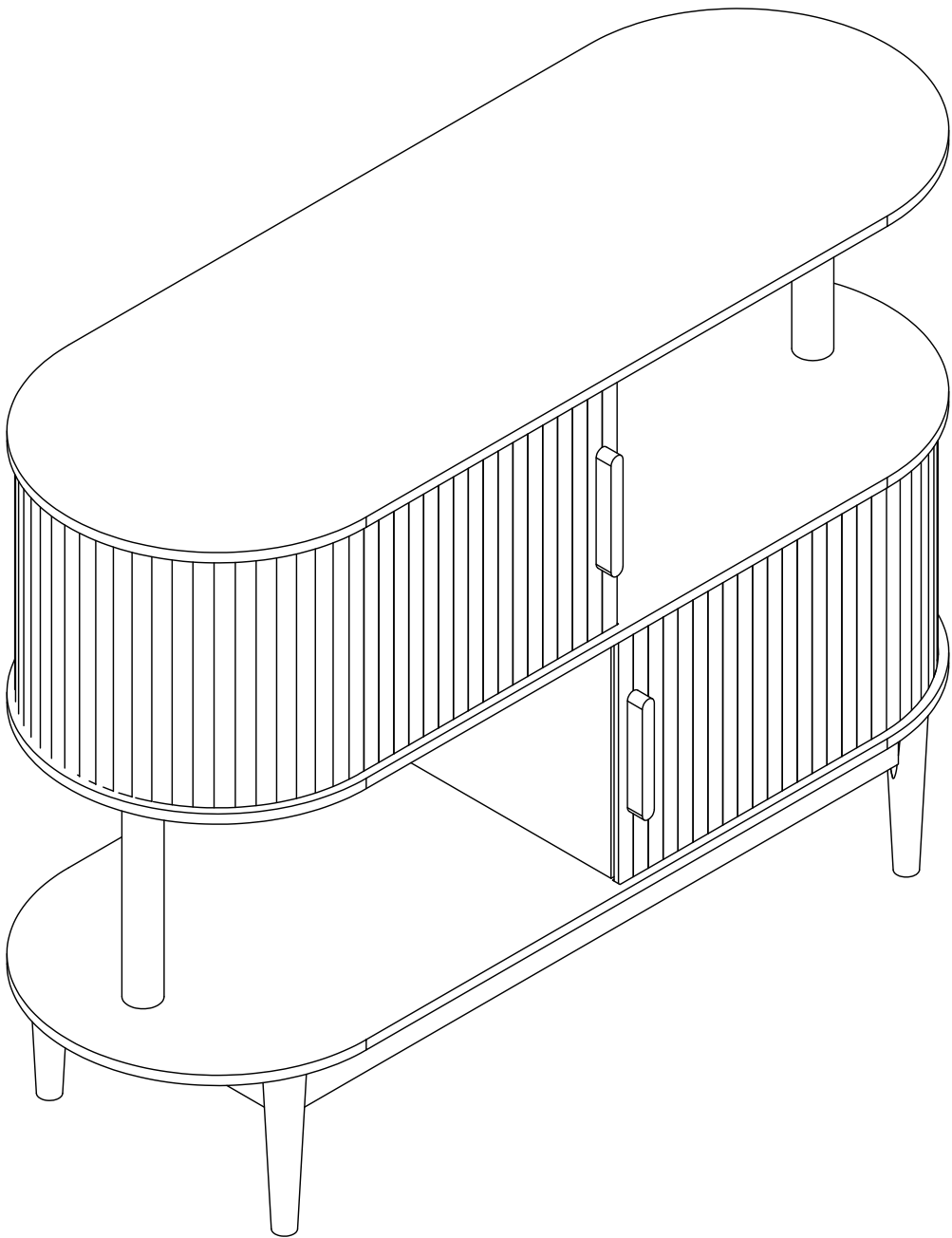

Assembling

What you need

- Use the packaging carton as a working surface to prevent product damage during assembly
- Phillips head screwdriver

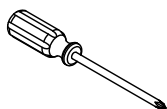

Weight Limitation

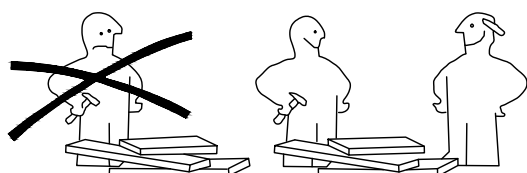

What' included

Code	Description	Qty
A	Cam Bolt M6X35MM	34
B	Cam Lock 15X10MM	34
C	Wooden Dowel M8X30MM	20
D	Screw M4X40MM	6
E	Screw M3.5X12MM	2
F	Slub screw	2
G	L-shaped metal sheet	2
H	Screw M3.5X14MM	24
I	Metal sheet	4
J	Screw M6X25MM	2
K	Screw M6X35MM	8
L	Foot nail	4
M	Hole position sticker	34
N	Solid wood handle	2
O	Cam Bolt M4X8MM	4
P	Anchor	2
Q	Wrench M4X55MM	1

The Hardwares

A

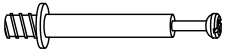

B



C

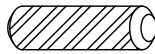

D

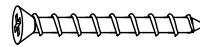

E



F

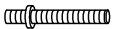

G



H



I



J



K



L



M



N



O



P

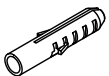

Q



IMPORTANT:

1. Do not tighten bolts / screws completely until all bolts / screws are lined up and inserted into holes.
2. Do not over tighten screws and bolts to avoid stripping
3. Please use hand tools to assemble this product, you can also use power tools (please use power tools carefully).

Included Accessories

Code	Description	Qty
1	Cabinet Top	1
2	Bottom Panel	1
3	Layer plate	1
4	Partition board	2
5	Back panel	2
6	Coaming panel	2
7	Support plate	2
8	Long strip board	2
9	short strip board	2
10	Wooden feet	4
11	Solid wood	2

The Accessoriess

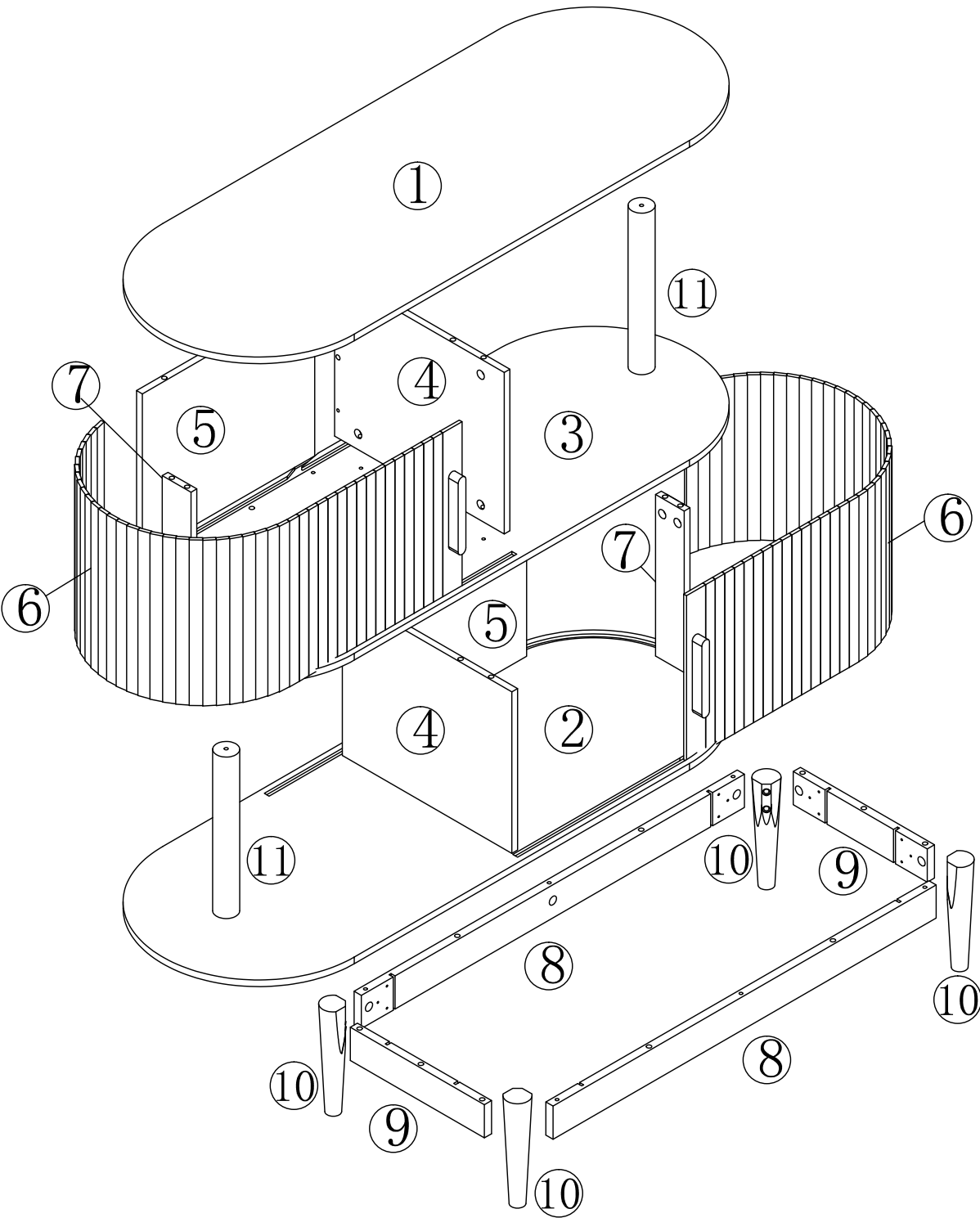

Step 1

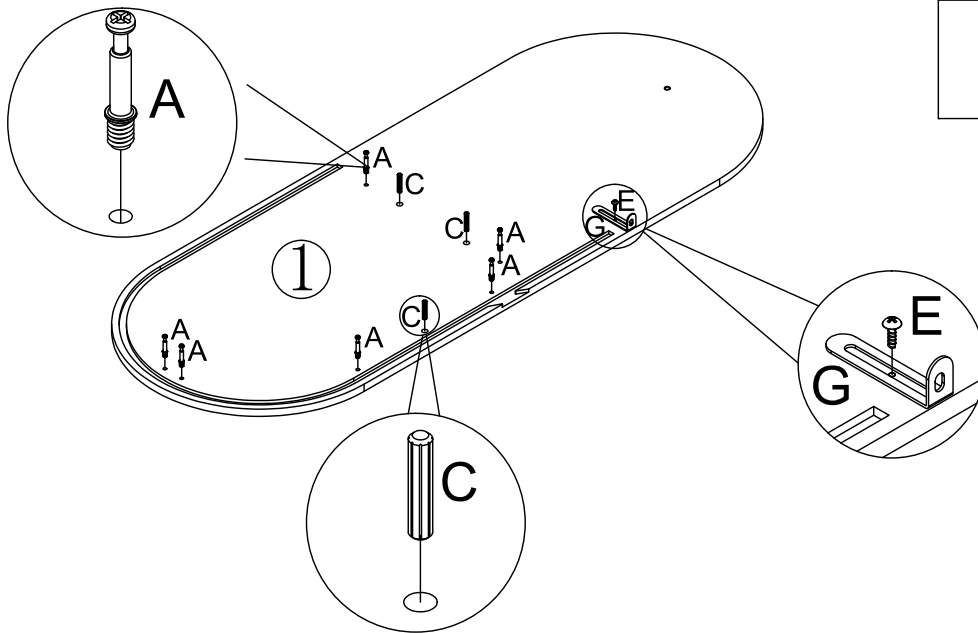
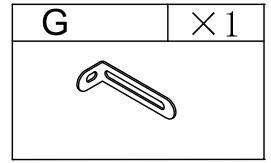
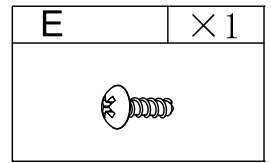
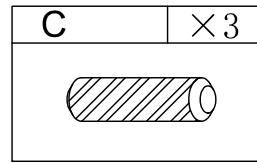
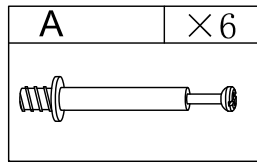

Step 2

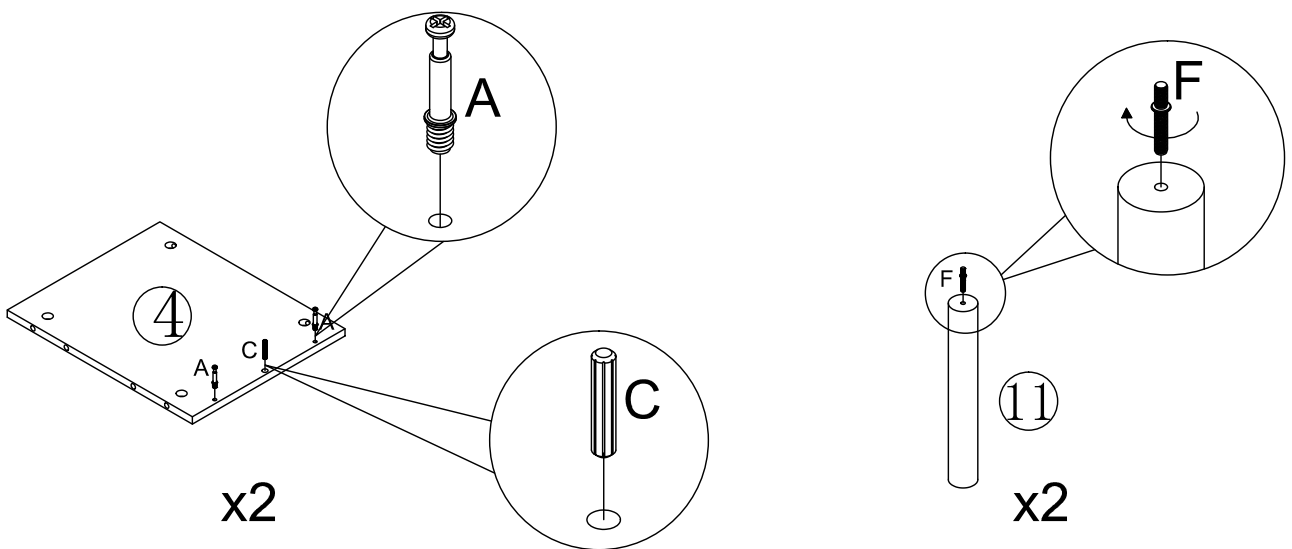
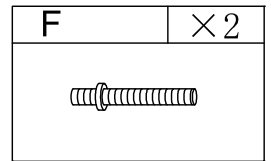
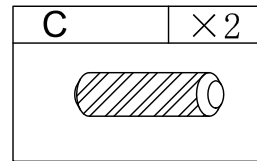
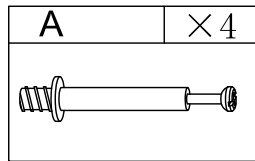

Step 3

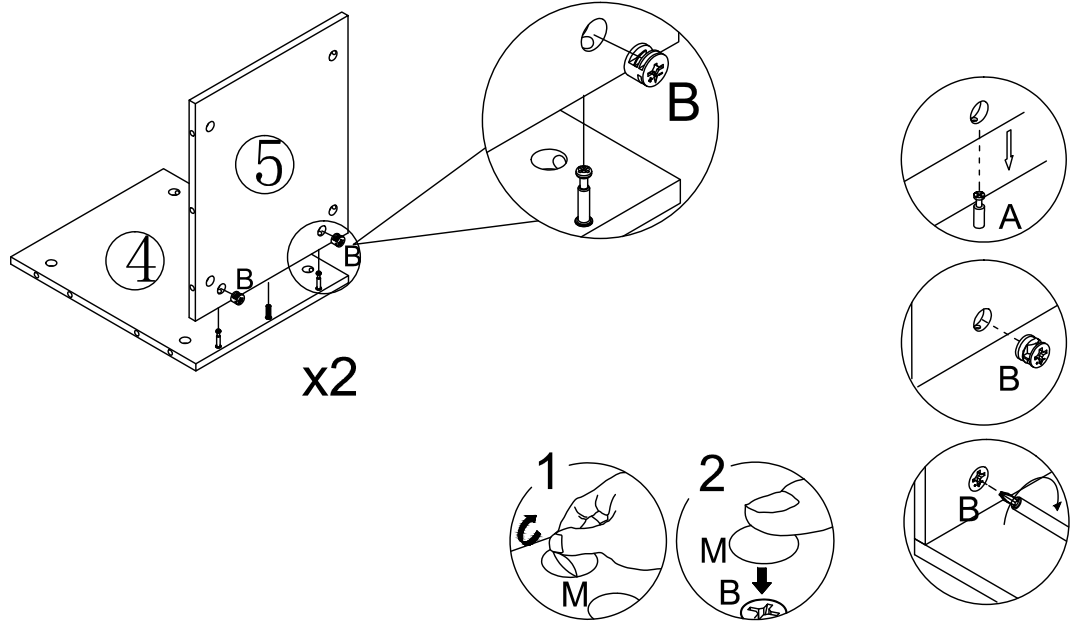
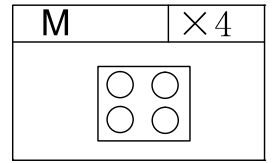
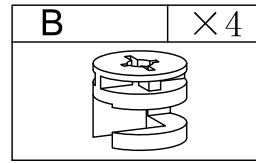

Step 4

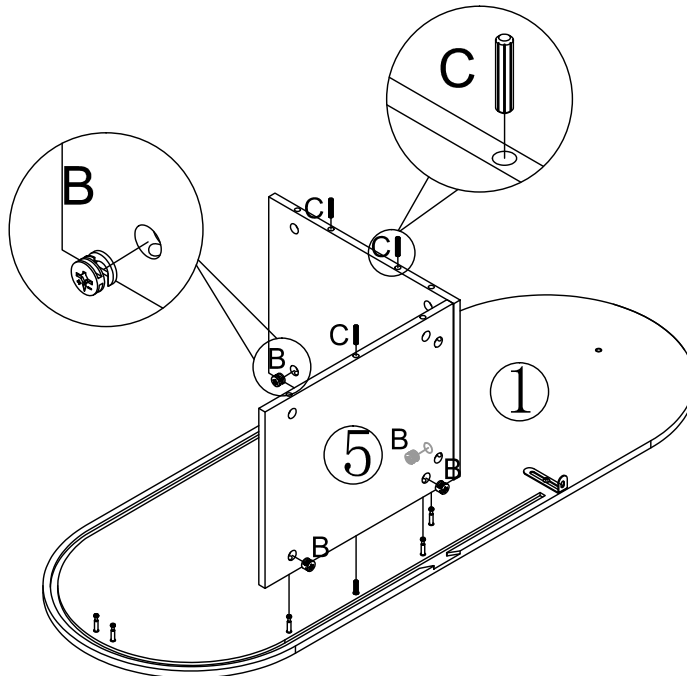
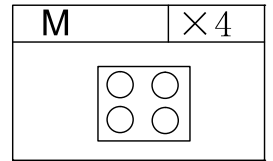
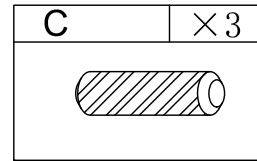
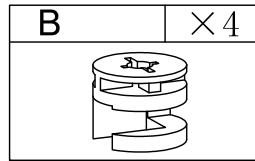

Step 5

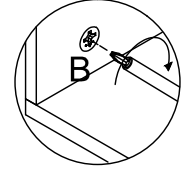
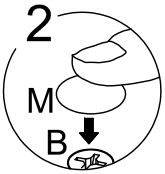
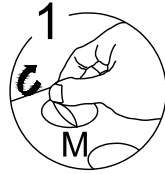
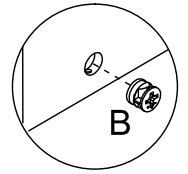
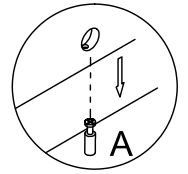
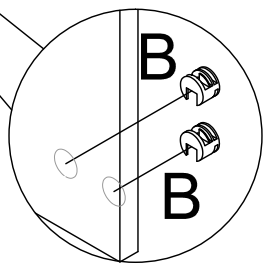
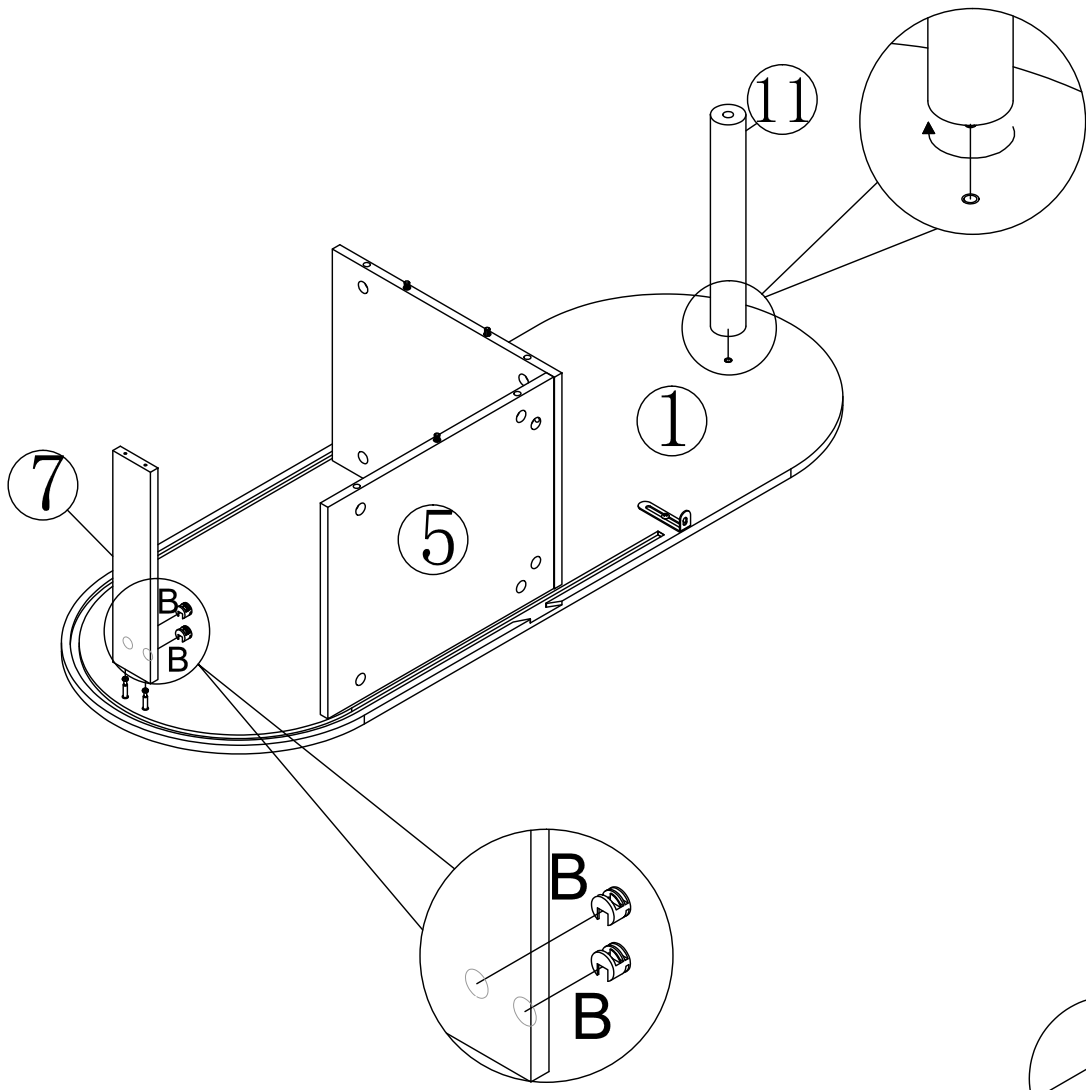
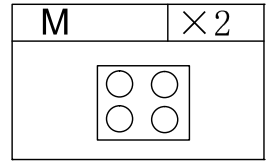
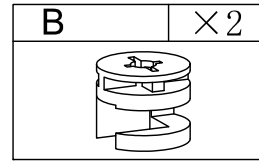

Step 6

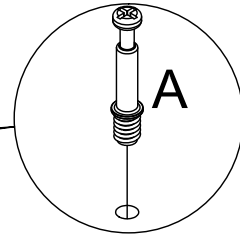
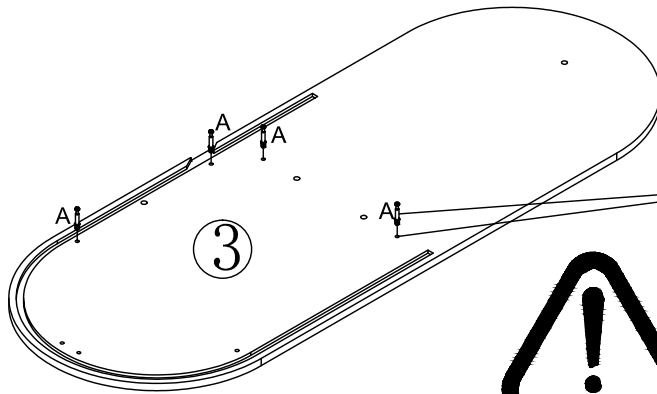
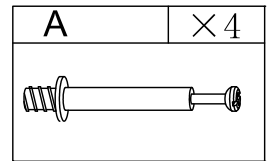

Please pay attention to the orientation of Board 3

Step 7

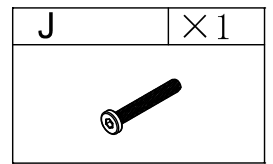
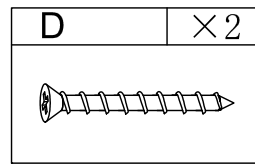
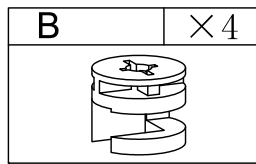

Note that the side marked with the arrow should face up

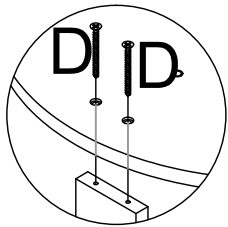
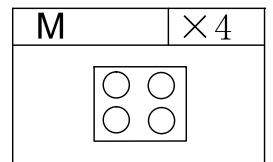
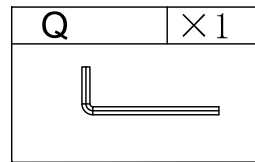

When tightening the D screw, please ensure it aligns with the hole position and lock it in carefully

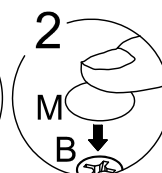
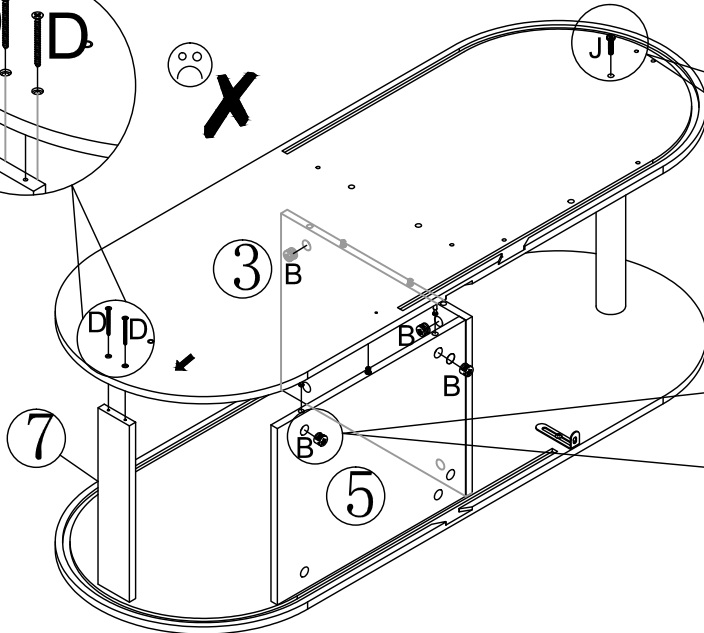
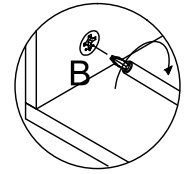
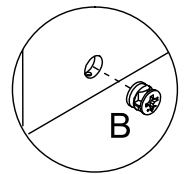
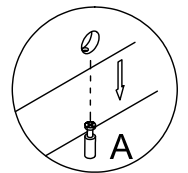
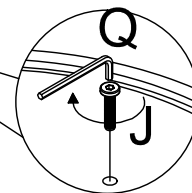
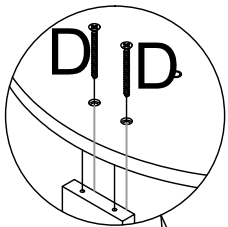

Step 8

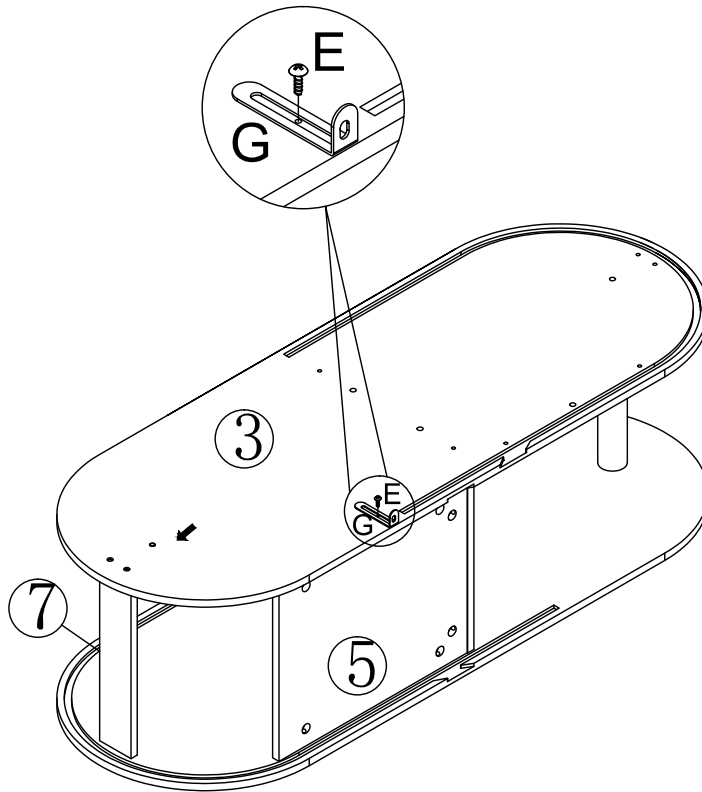
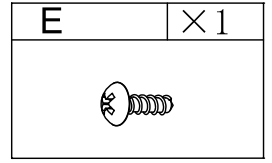
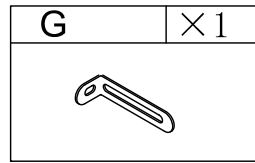

Step 9

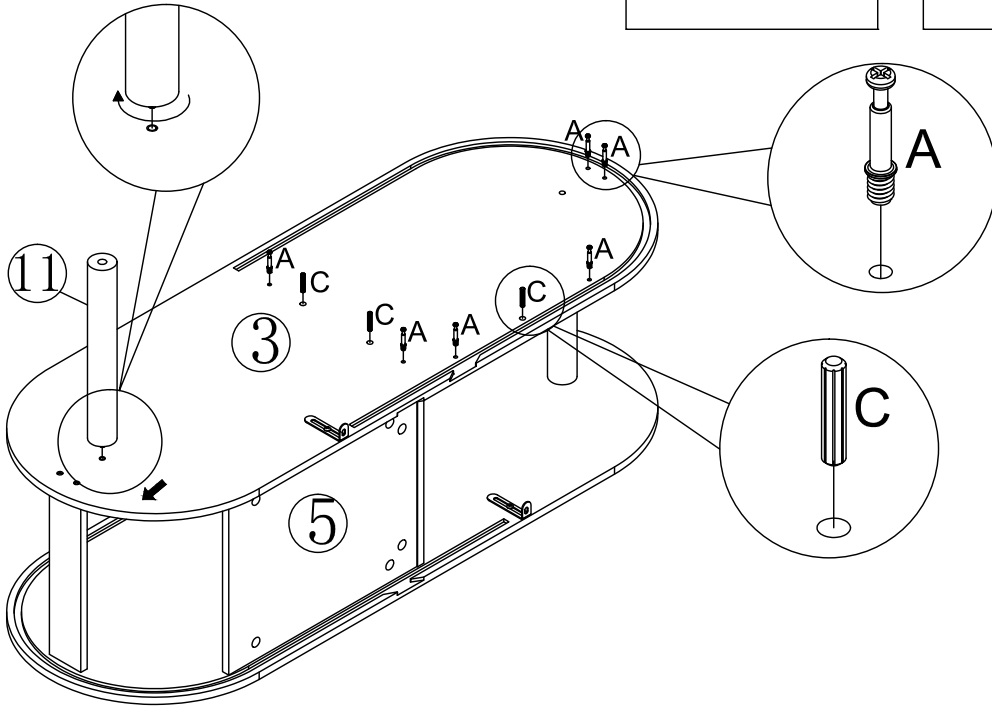
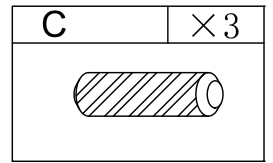
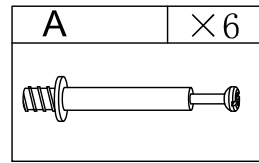

Step 10

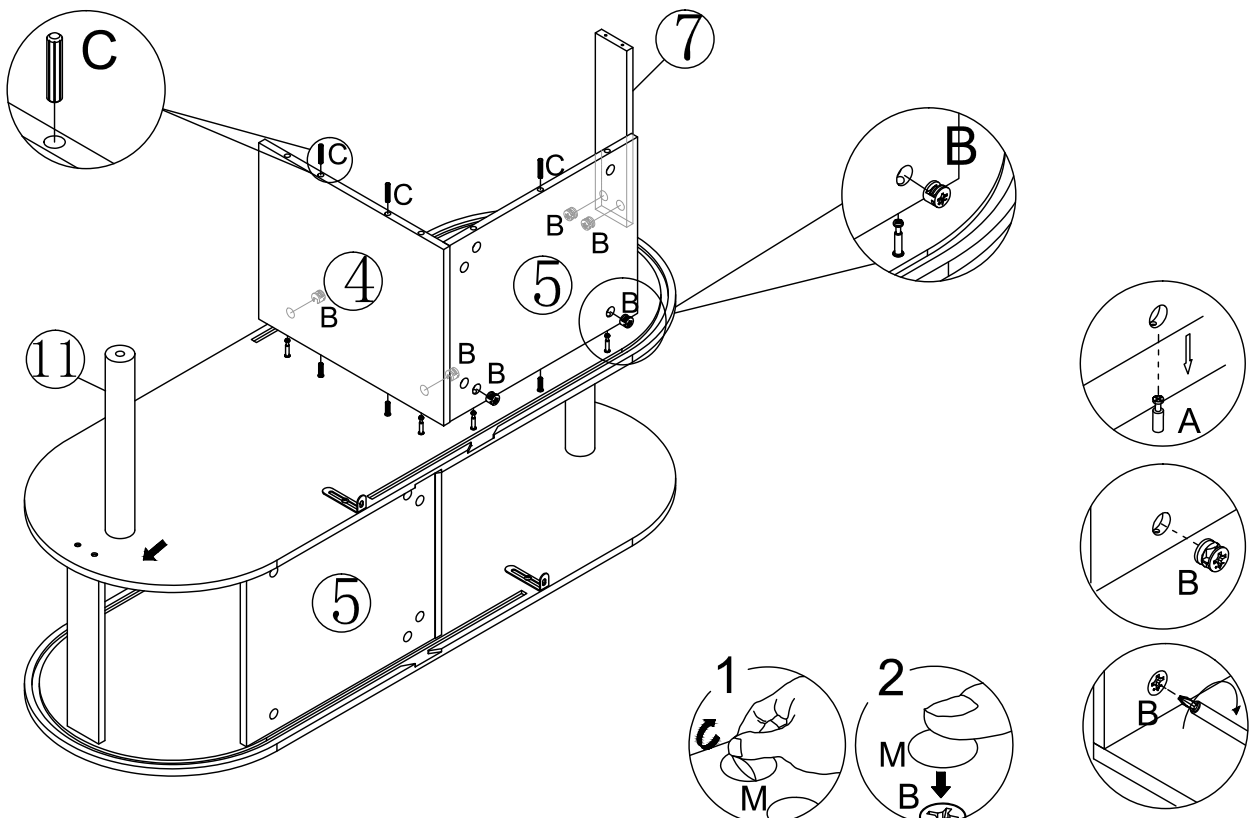
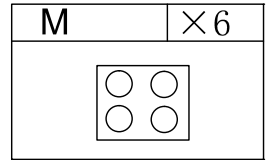
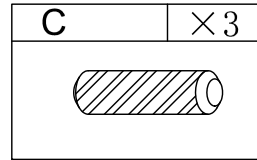
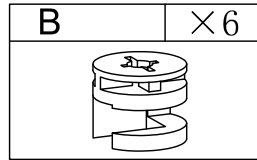

Step 11

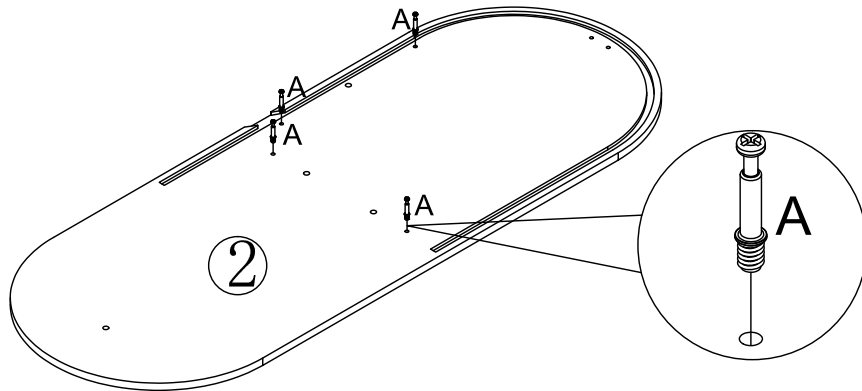
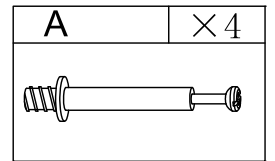

Step 12

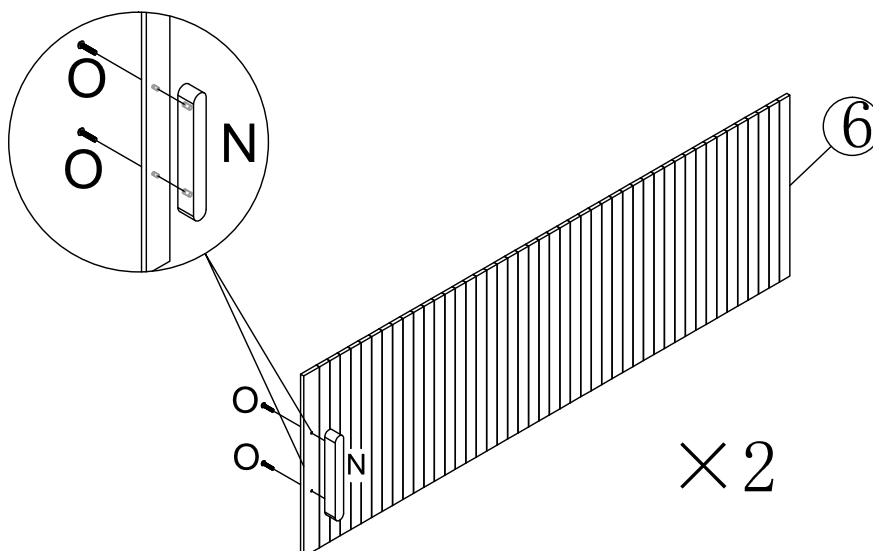
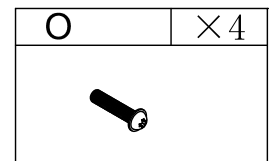
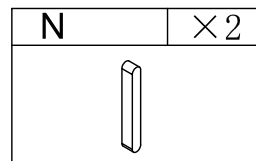

Step 13

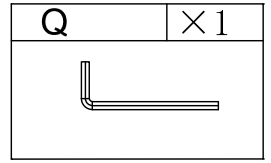
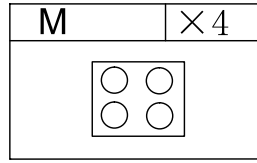
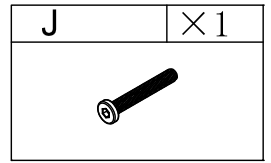
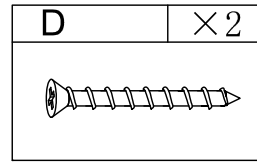
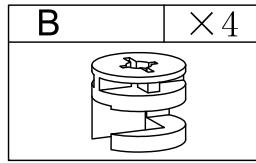

When tightening the D screw, please ensure it aligns with the hole position and lock it in carefully

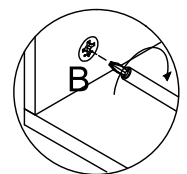
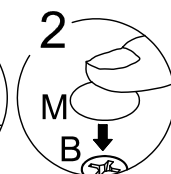
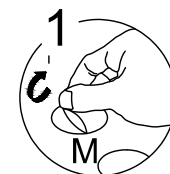
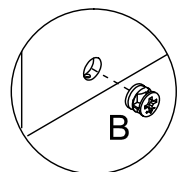
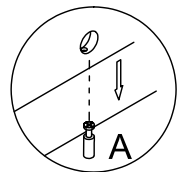
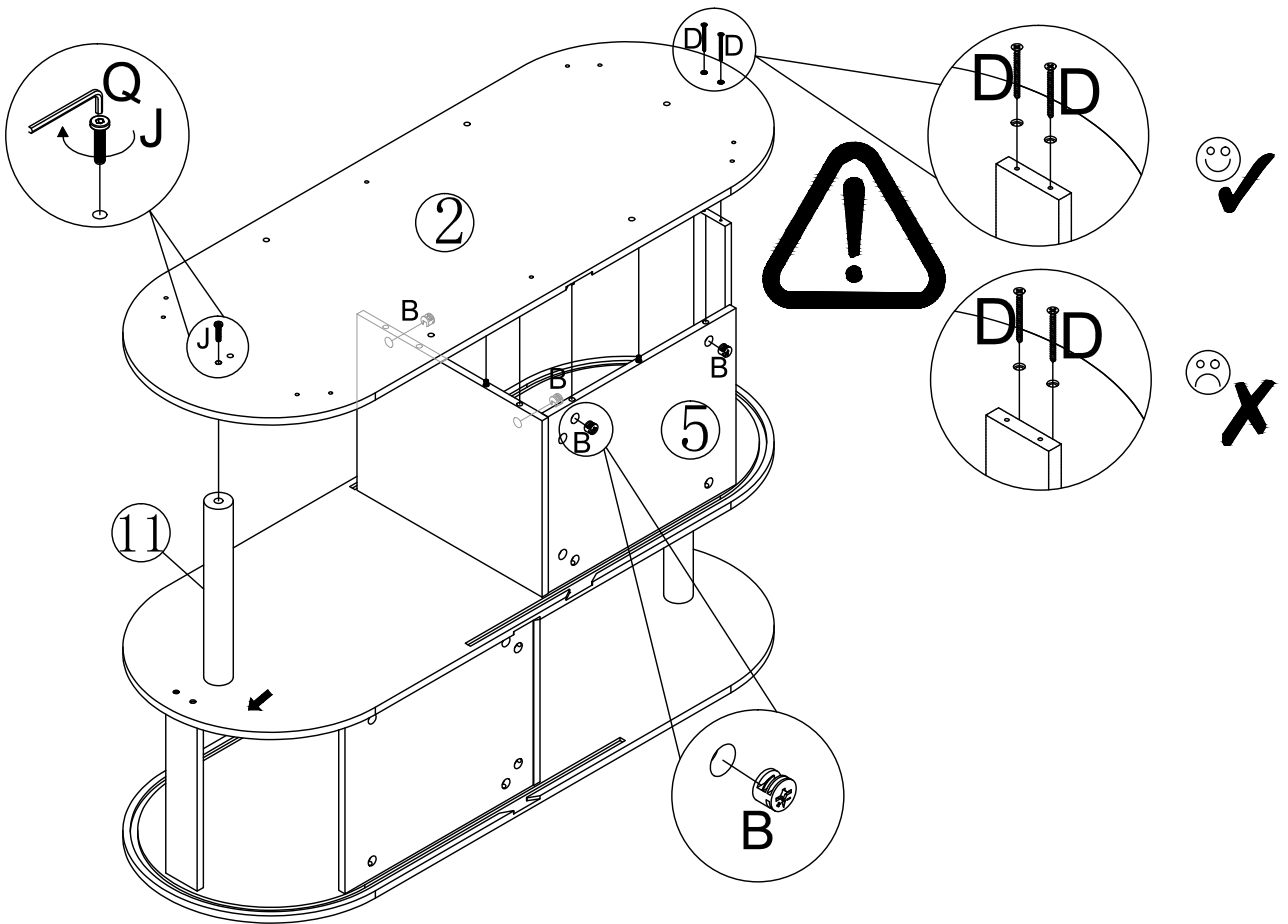

Step 14

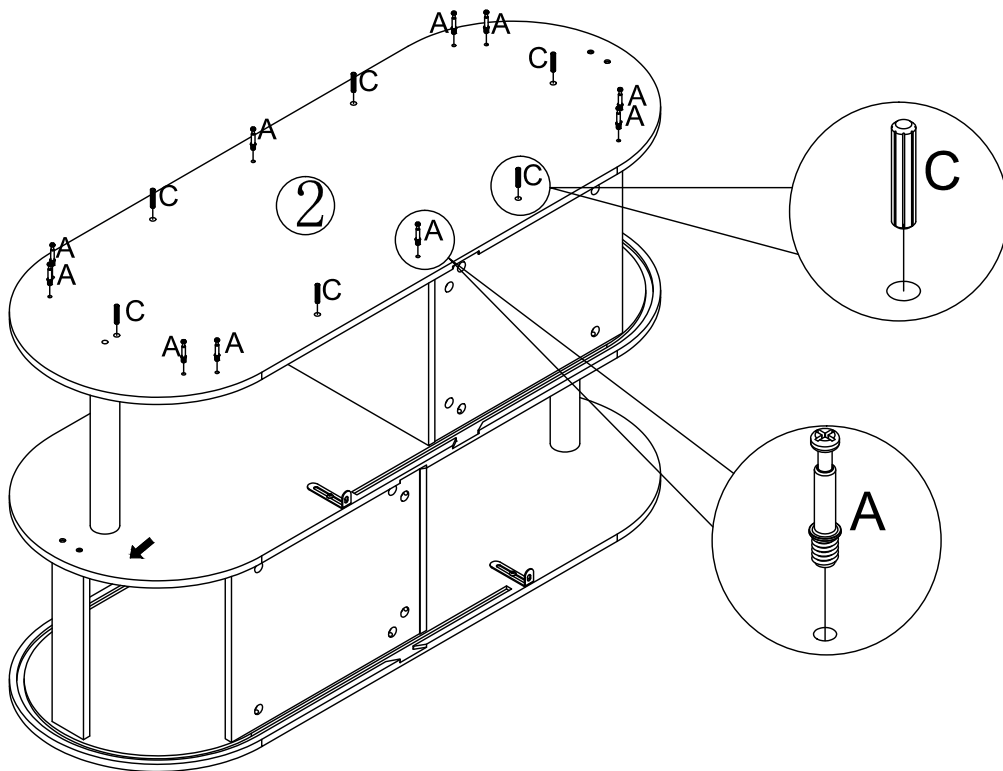
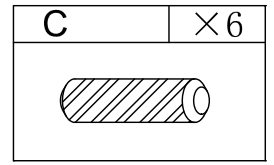
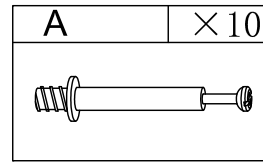

Step 15

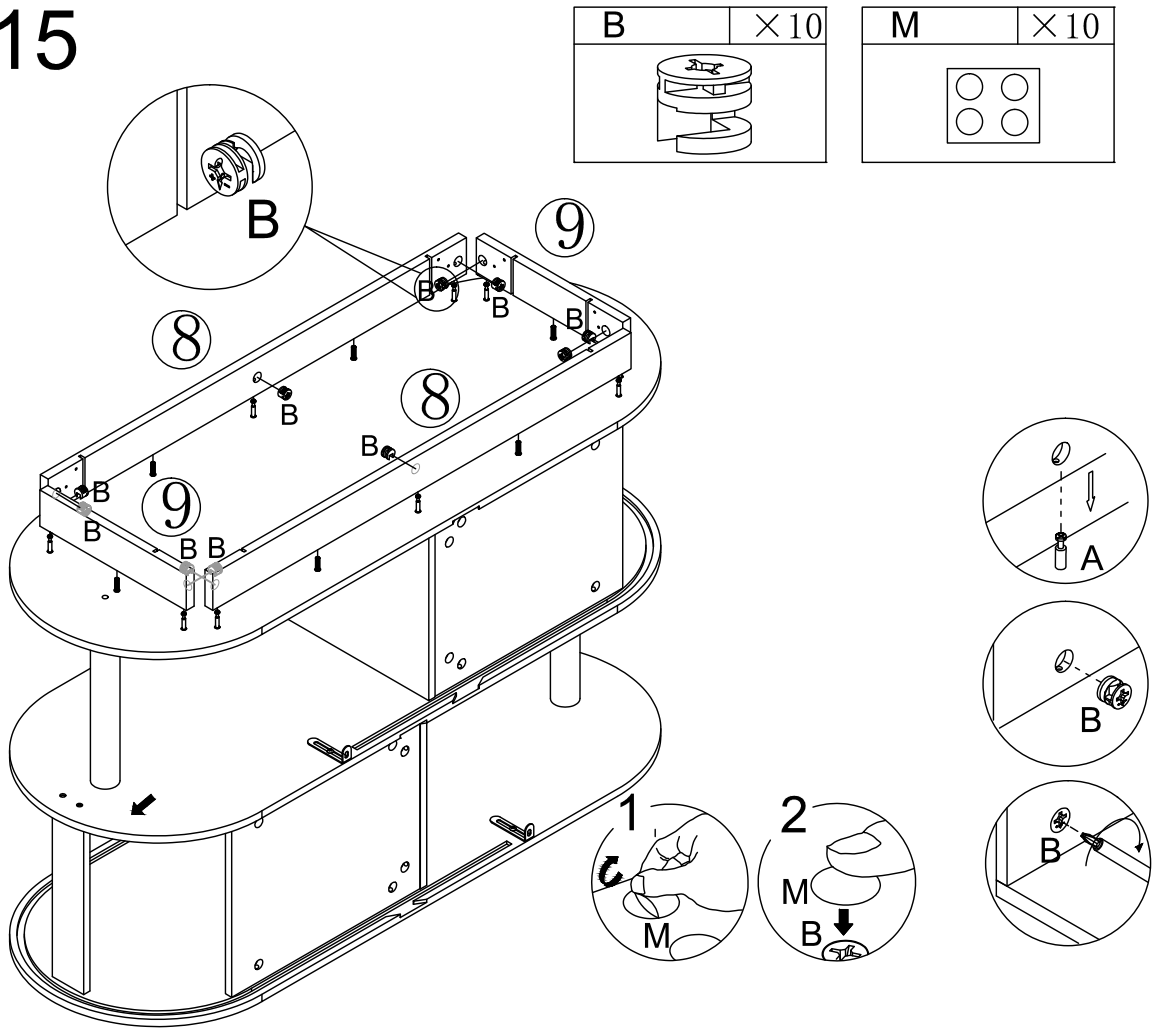

Step 16

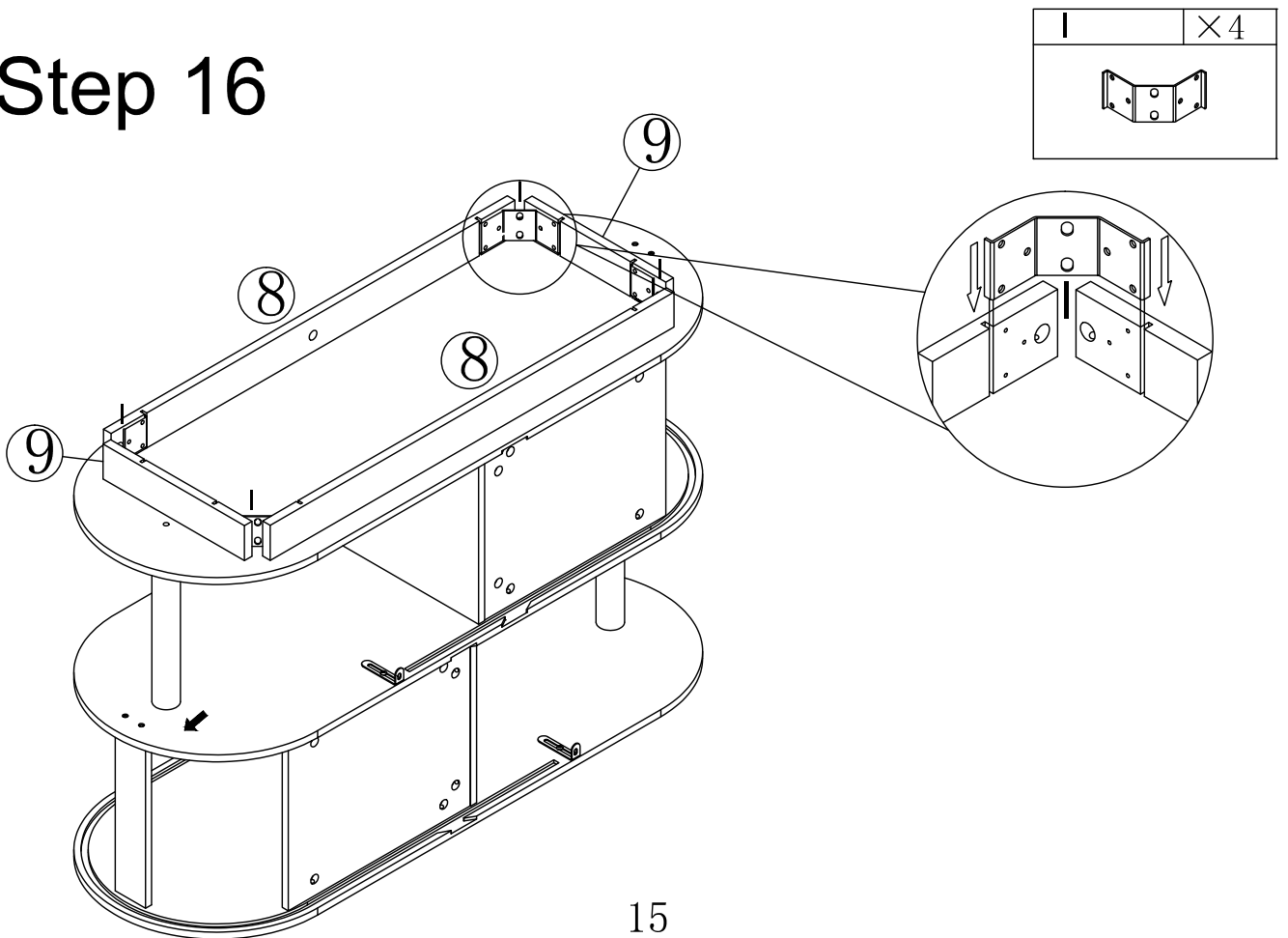

Step 17

H	×24
	

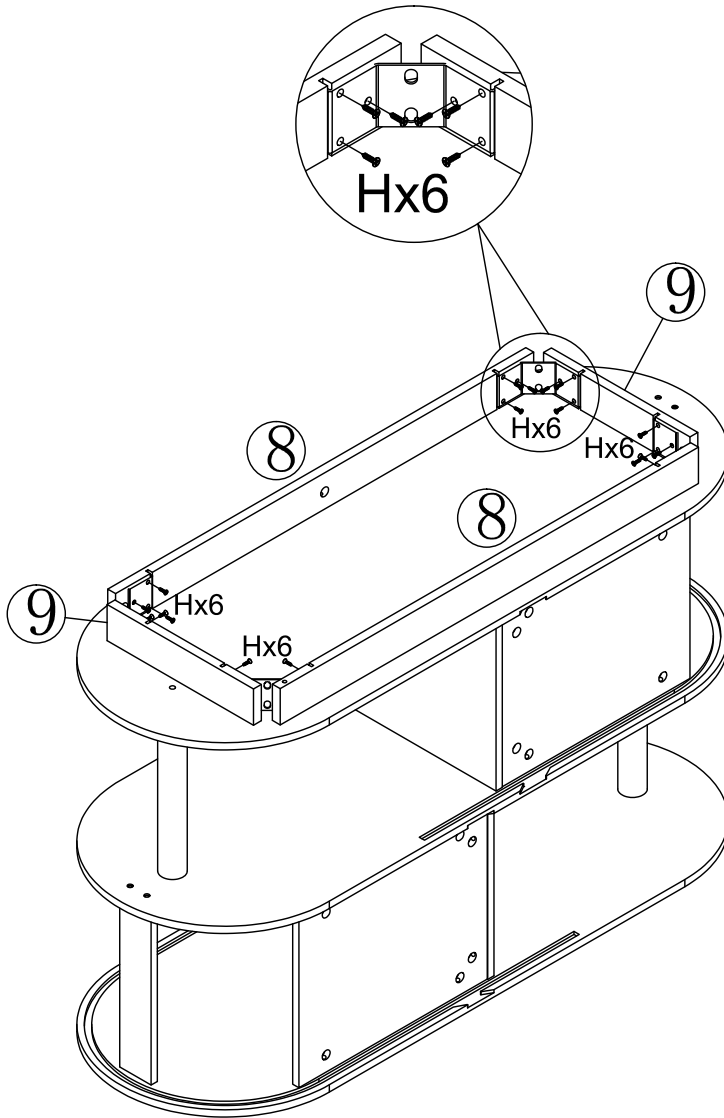

Step 18

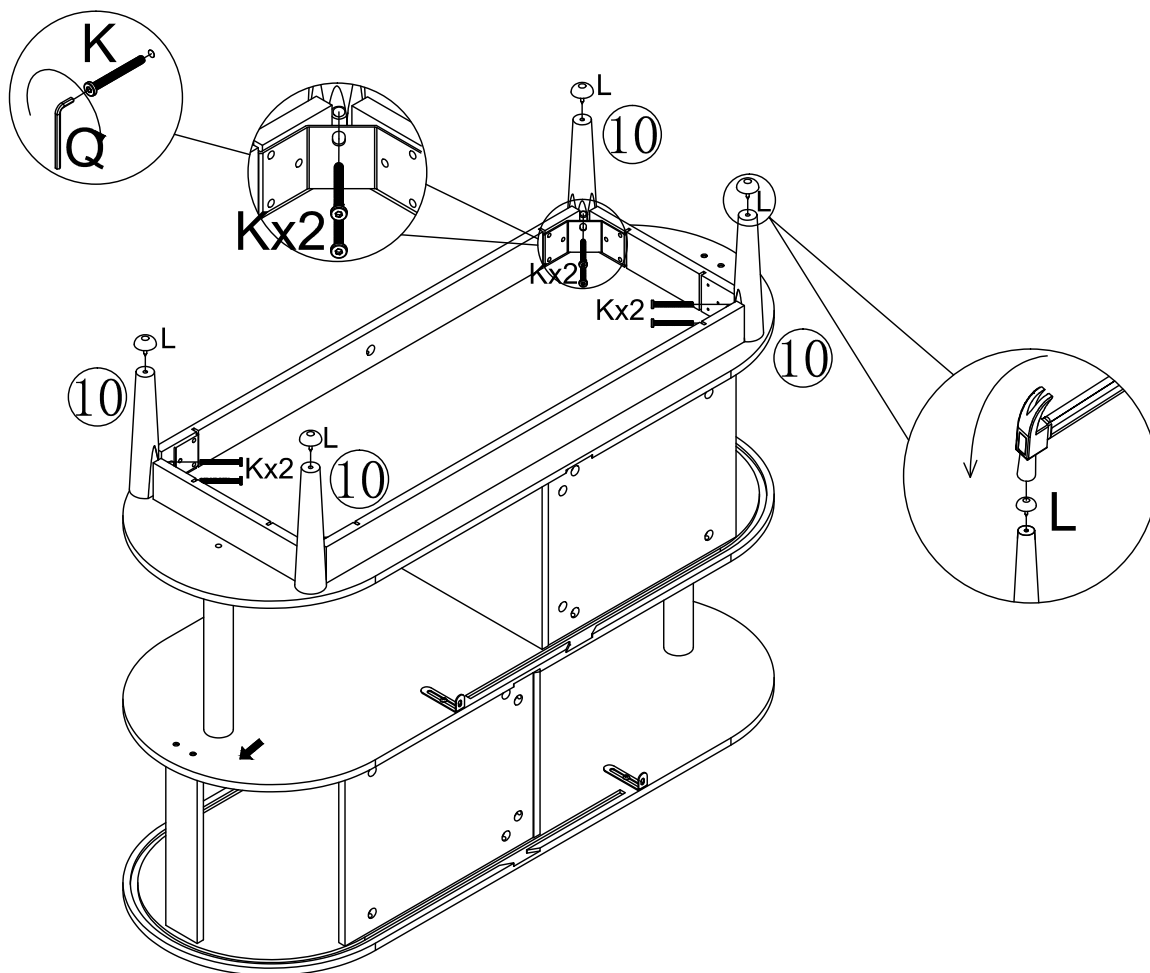
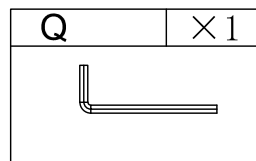
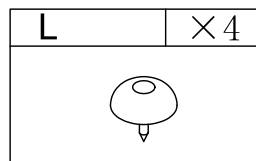
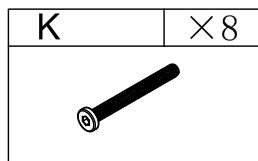

Step 19

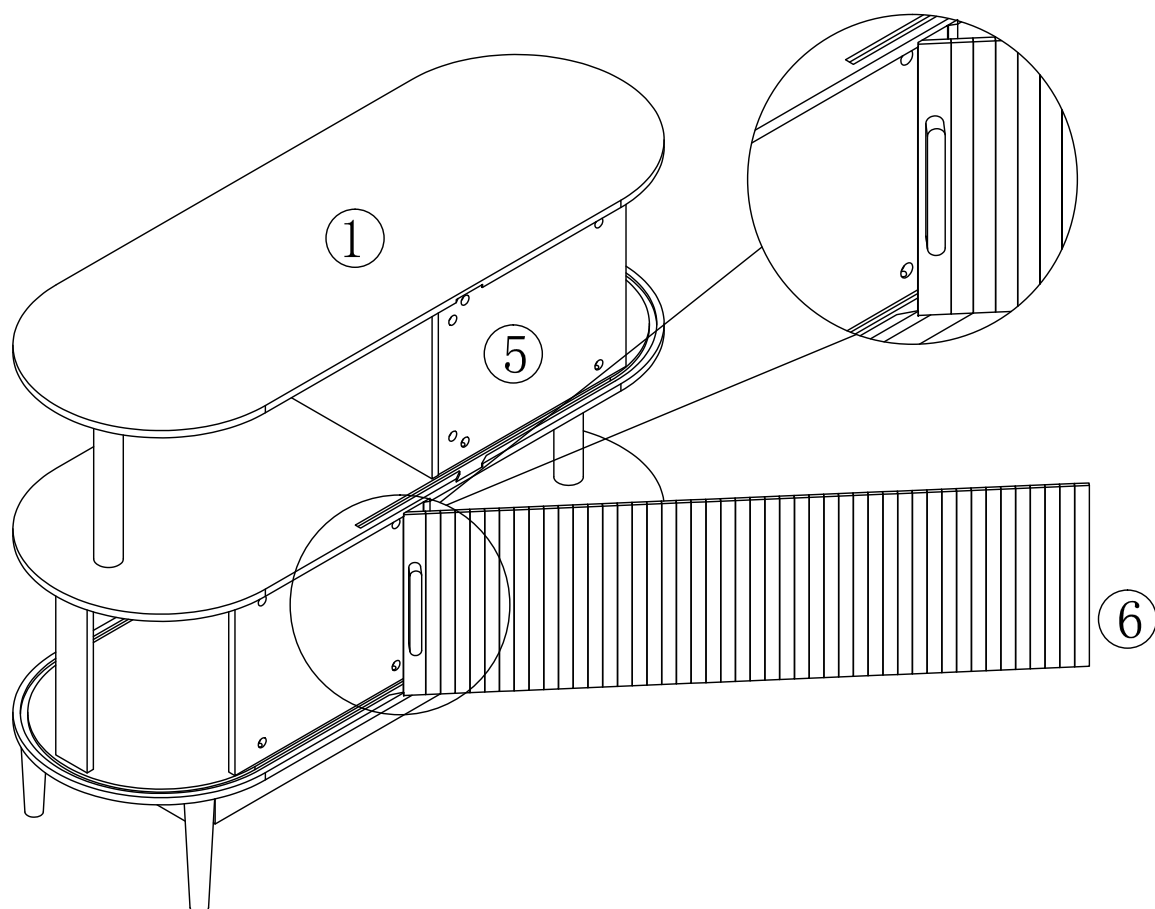

When the No. 6 plate is pushed into, it should be aligned with the upper and lower slots, with the drawing surface facing outward and the smooth surface facing inward

Step 20

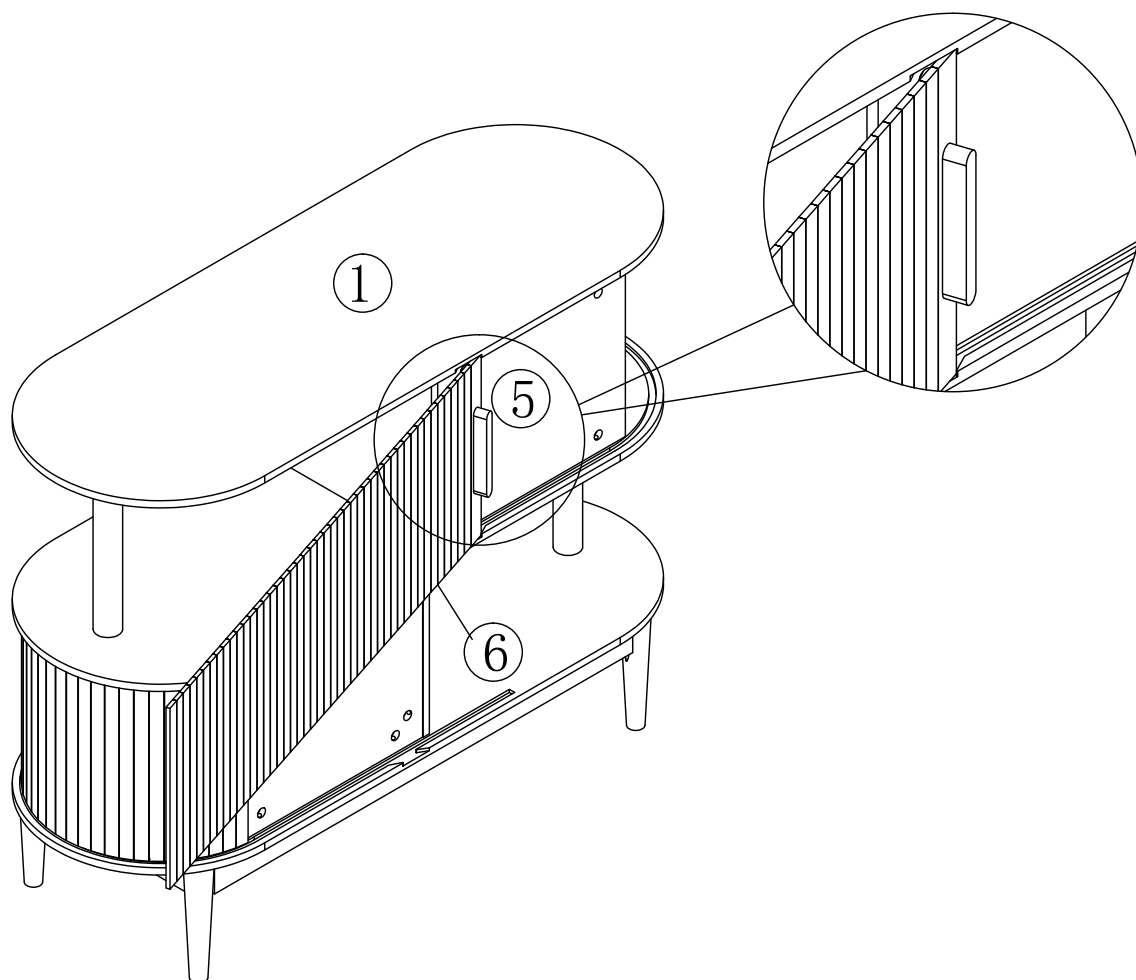

When the No. 6 plate is pushed into, it should be aligned with the upper and lower slots, with the drawing surface facing outward and the smooth surface facing inward

Step 21

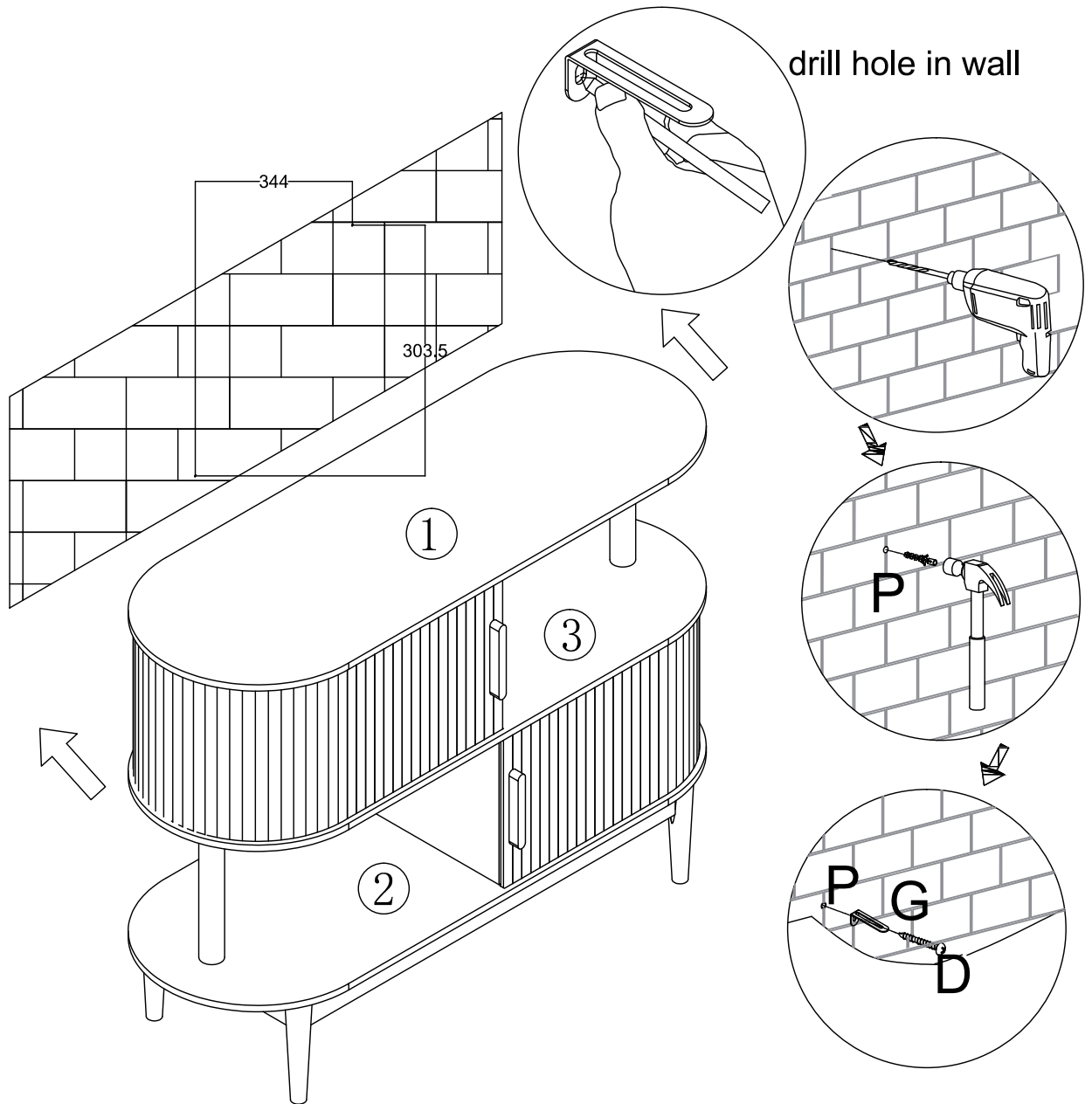
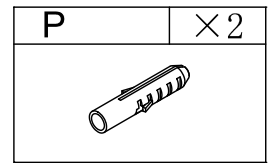
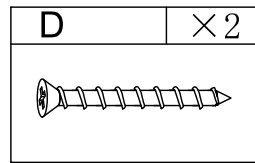

Please install the anti-tipping device correctly according to the dimensions shown in the diagram

Step 22

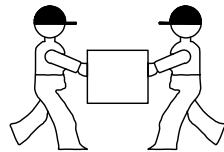
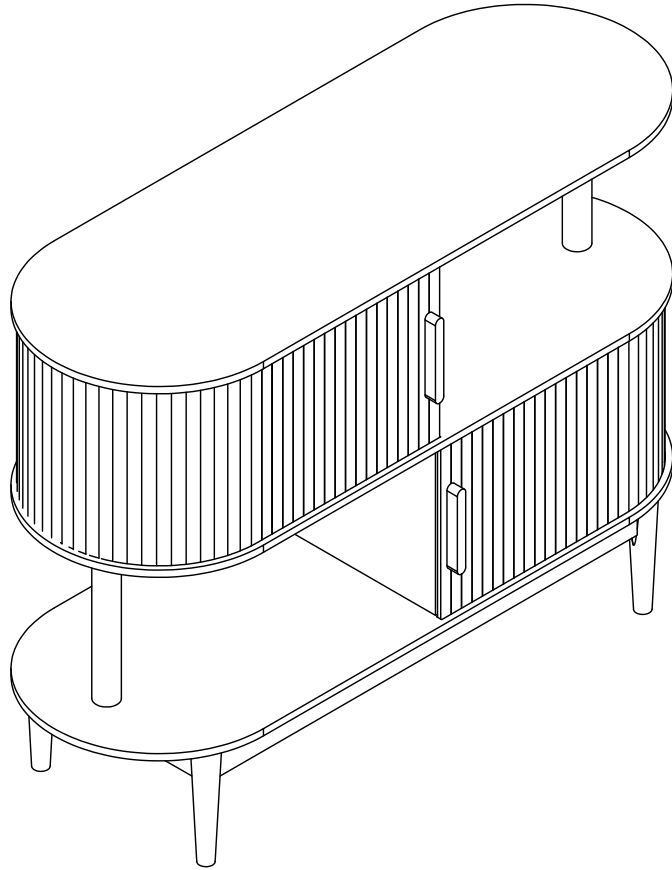

Two people work together to move the table.
Make sure you lift it off the ground.
Don't push and pull.