

Stuckliste /Liste bloquée

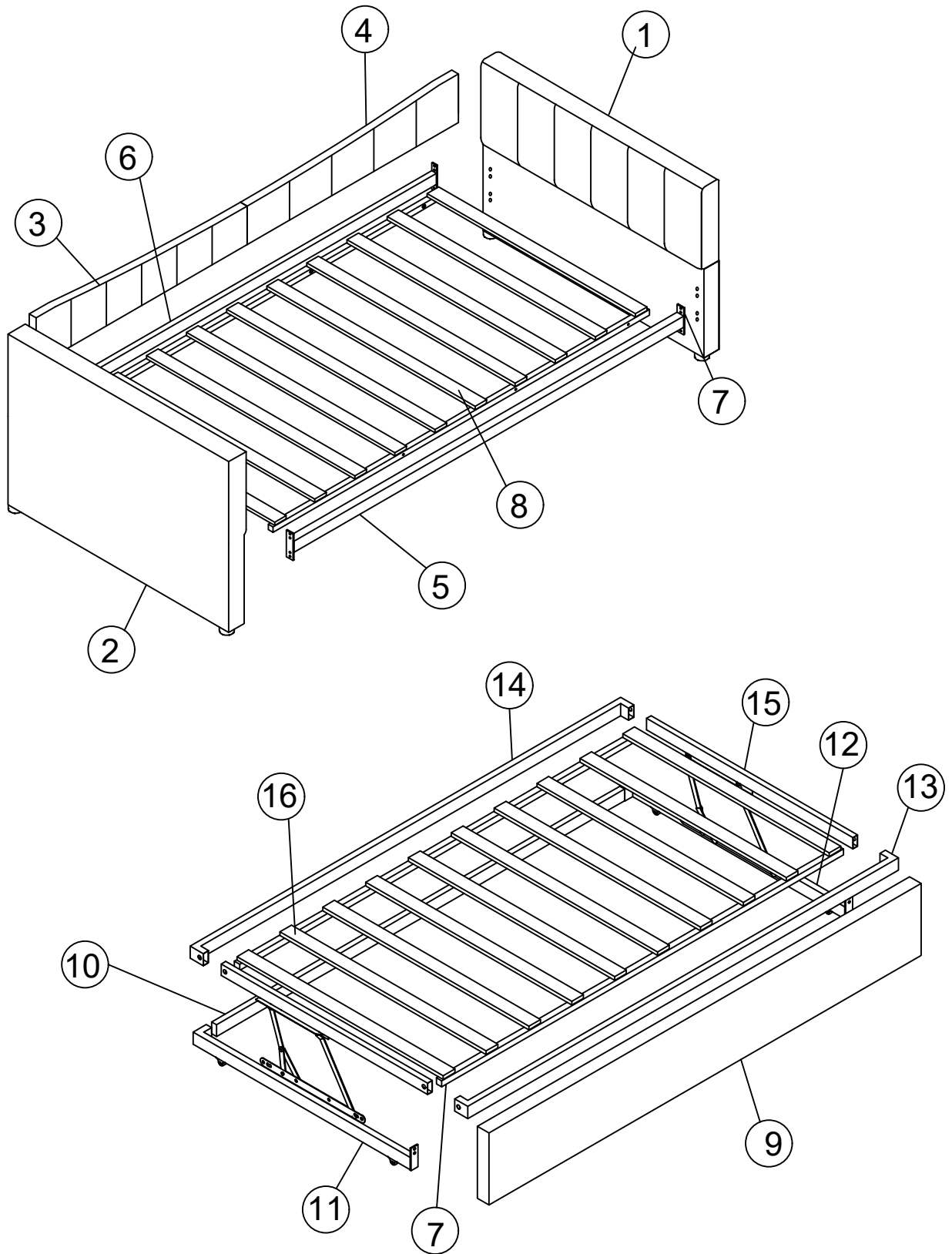

3

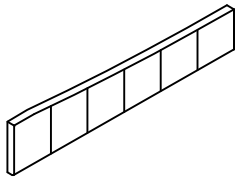

Seitenschienen-1Stück

4

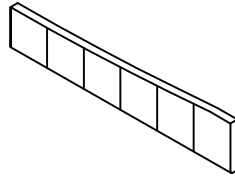

Seitenschienen-1Stück

5

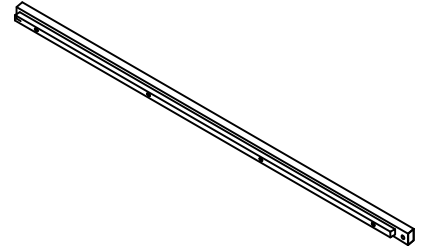

Untere Schiene -1Stück

6

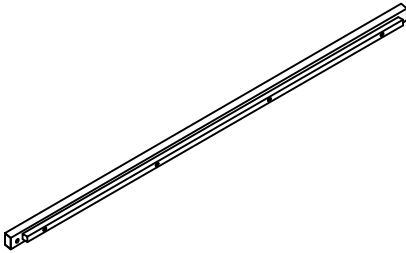

Untere Schiene -1Stück

9

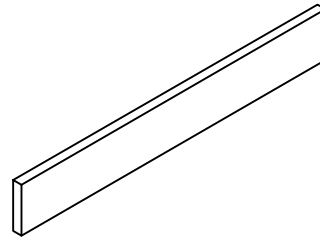

Seitenschienen-1Stück

10

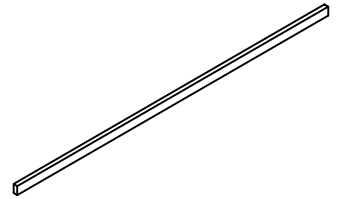

Untere Schiene -1Stück

11

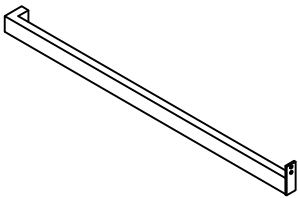

Untere Schiene -1Stück

12

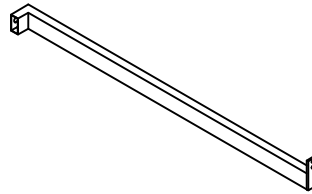

Untere Schiene -1Stück

13

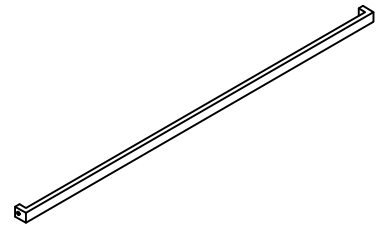

Untere Schiene -1Stück

14

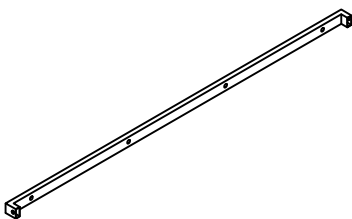

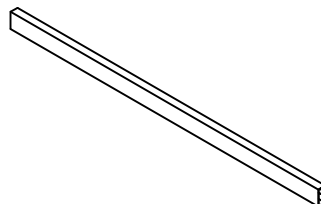

Untere Schiene -1Stück

15

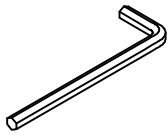
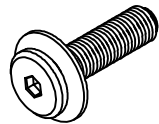

Untere Schiene -2Stück

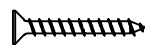
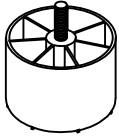
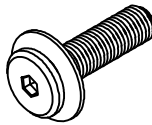
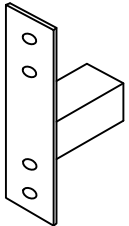
<p>A</p>  <p>25*75mm=1PC</p>	<p>B</p>  <p>1/4*20mm = 44 pcs</p>	<p>D</p>  <p>100*25*2mm =2pcs</p>
<p>E</p>  <p>3.5*30mm =40 pcs</p>	<p>F</p>  <p>4 pcs</p>	<p>G</p>  <p>1/4*40mm = 4 pcs</p>
<p>7</p>  <p>Untere Schiene -4Stück</p>		

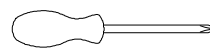

Assembly Tools Required (Not Included)

Wichtiger Hinweis:

Bestatigen Sie bitte alle Komponenten und Schrauben vor der Montage. Bitte wenden Sie sich an uns, falls einige Teile oder Schrauben im Paket fehlt sind.

Outils d'assemblage requis (non inclus)

Signification du Wichtiger :

Bestatigen Sie bitte alle Komponenten und Schrauben vor der Montage. Bitte wenden Sie sich an uns, Falls einige Teile ou Schrauben im paket fehlt sind.

C

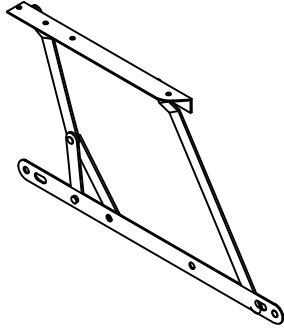

2pcs

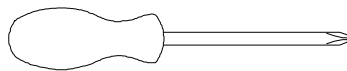

Assembly Tools Required (Not Included)

Wichtiger Hinweis:

Bestatigen Sie bitte alle Komponenten und Schrauben vor der Montage. Bitte wenden Sie sich an uns, falls einige Teile oder Schrauben im Paket fehlt sind.

Outils d'assemblage requis (non inclus)

Signification du Wichtiger :

Bestatigen Sie bitte alle Komponenten and Schrauben vor der Montage. Bitte wenden Sie sich an us, Falls einige Teile ou Schrauben im paket fehlt sind.

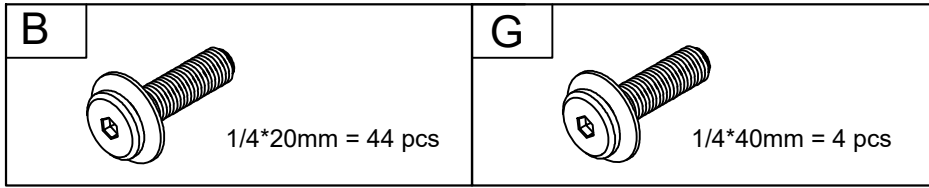

DK: Bitte beachten Sie, dass die Formen der Schrauben **B** und **G** ähnlich sind. Bitte installieren Sie entsprechend der Anleitung und unterscheiden Sie sie!



UK: Please note that the shapes of screw **B** and **G** are similar. Please install according to the instructions and distinguish them!

FK: Notez que les vis **B** et **G** ont des formes similaires. Veuillez installer en suivant les instructions pour les séparer!

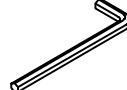
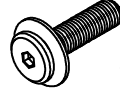

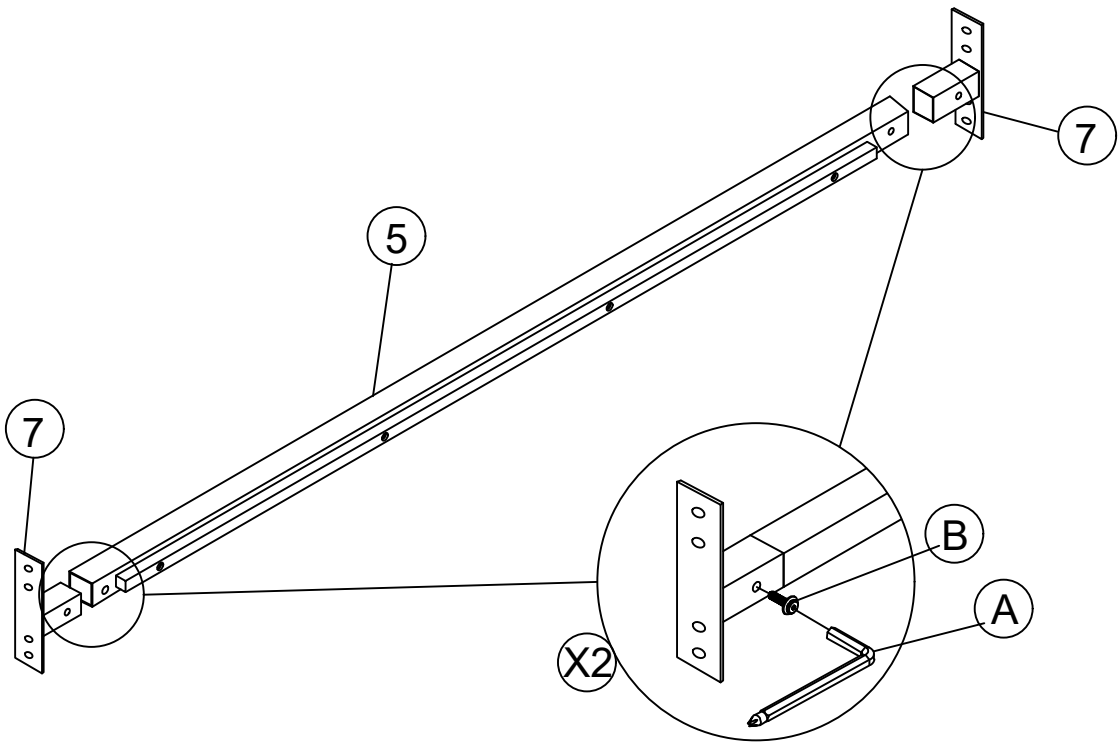
STEP 1
Schritt 1

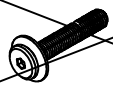
A	 25*75mm	1 PCS
B	 1/4*20mm	2 PCS



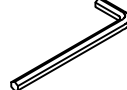

 1/4*40mm
 1/4*20mm

STEP 2
Schritt 2

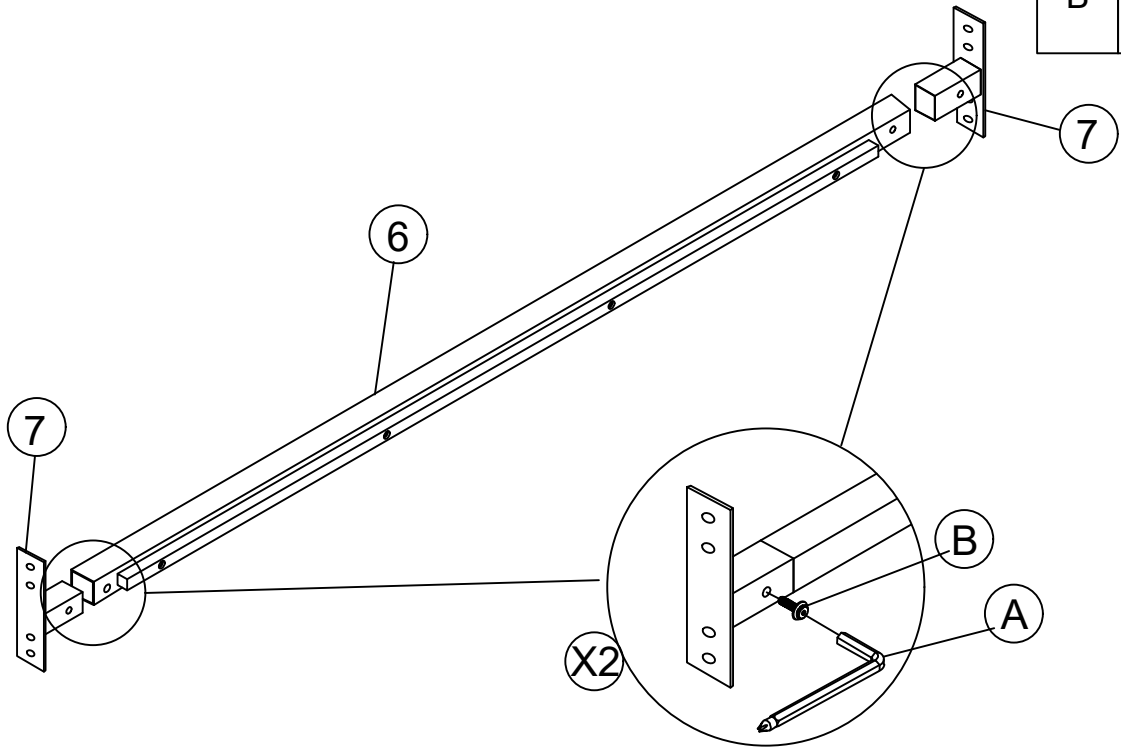
A	 25*75mm	1 PCS
B	 1/4*20mm	2 PCS

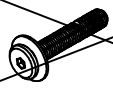

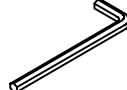
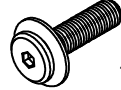

 1/4*40mm
 1/4*20mm

STEP 3
Schritt 3

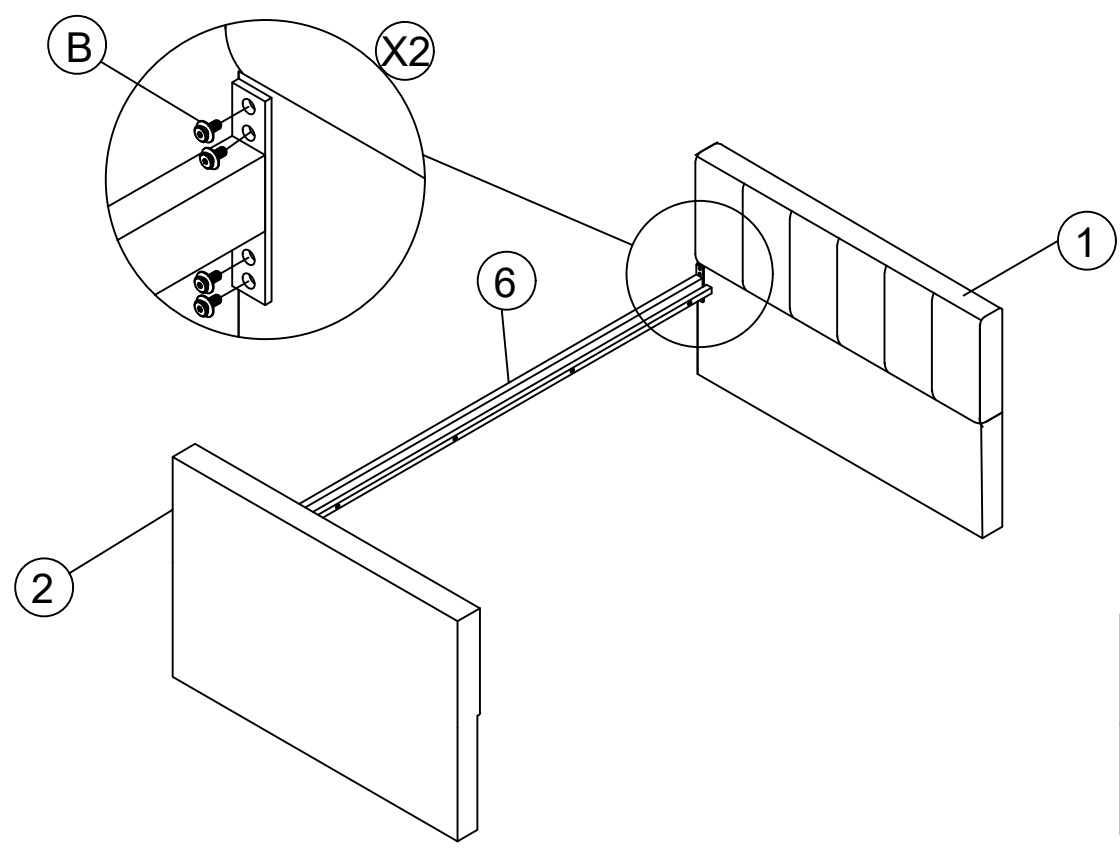
A	 25*75mm	1 PCS
B	 1/4*20mm	8 PCS

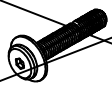

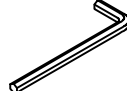
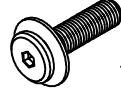

	1/4*40mm
	1/4*20mm

STEP 4
Schritt 4

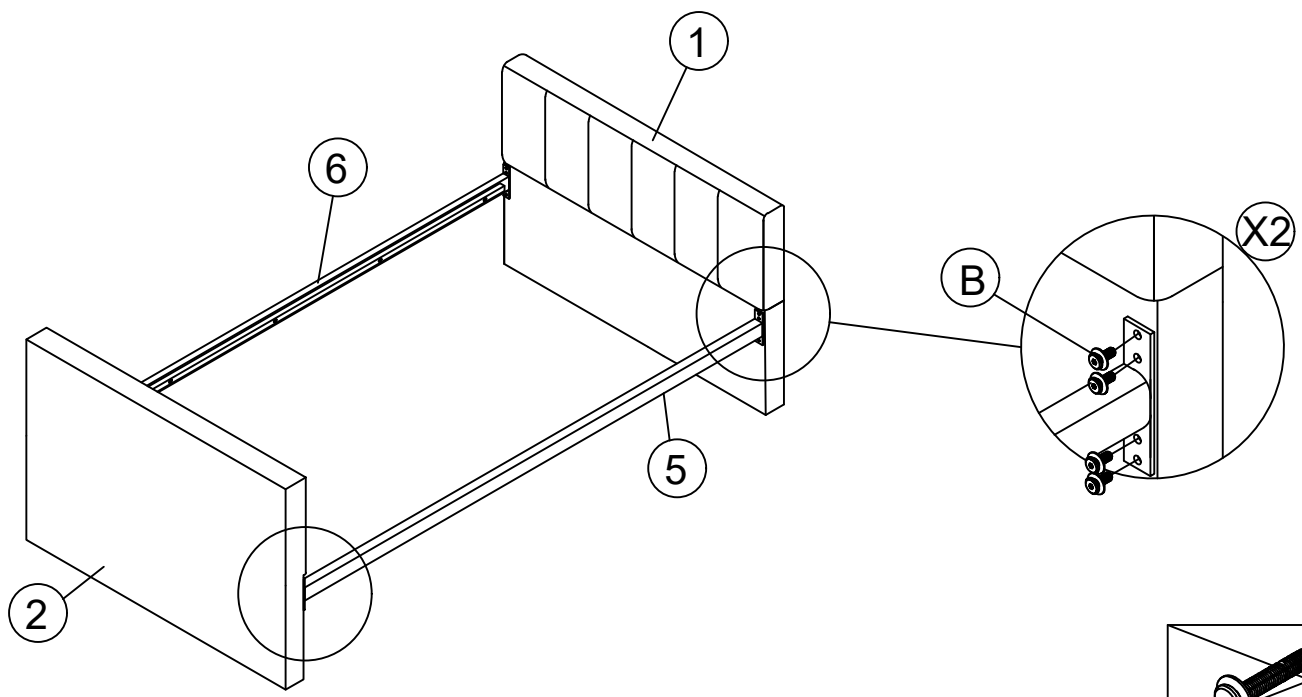
A	 25*75mm	1 PCS
B	 1/4*20mm	8 PCS

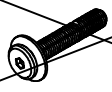

	1/4*40mm
	1/4*20mm

STEP 5
Schritt 5

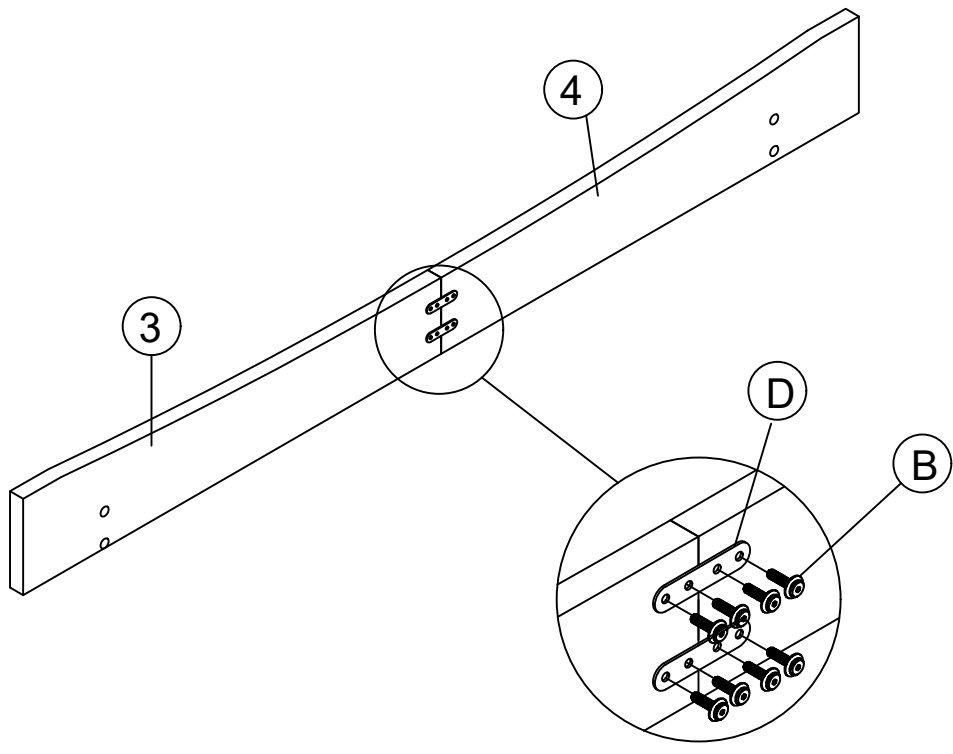

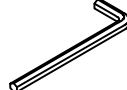
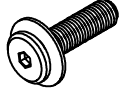
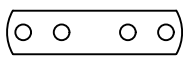
A	 25*75mm	1 PCS
B	 1/4*20mm	8 PCS
D	 100*25*2mm	2 PCS

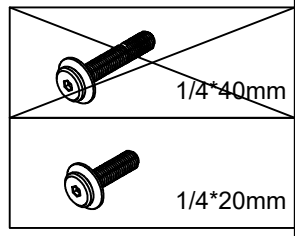

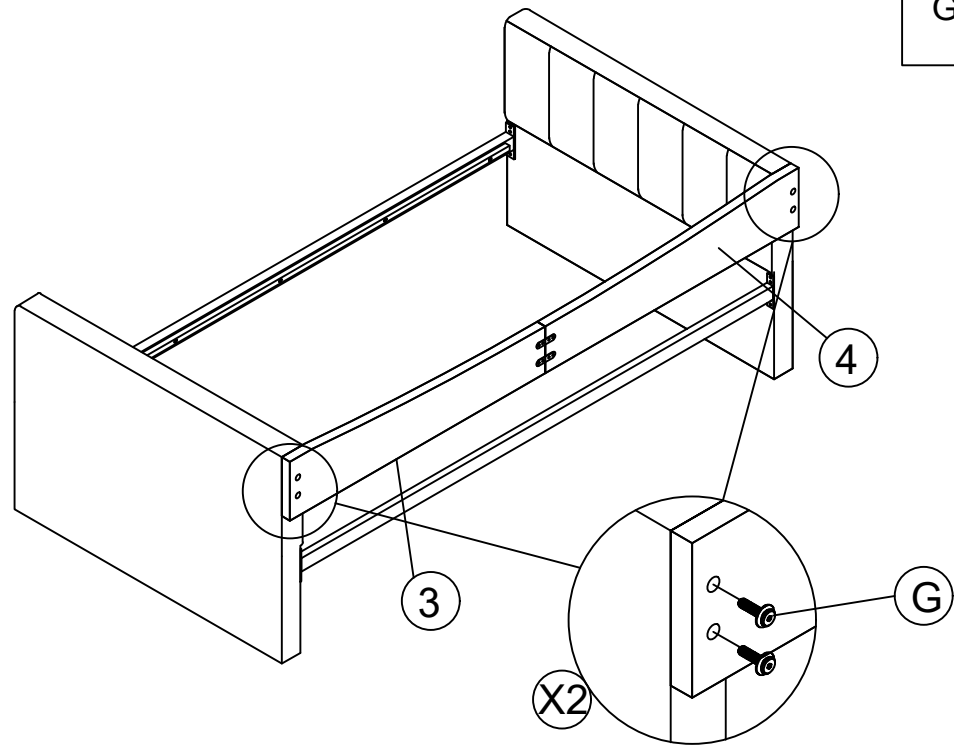

STEP 6X2
Schritt 6X2

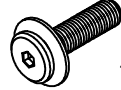

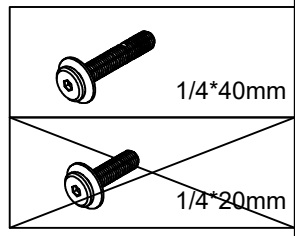
A	 25*75mm	1 PCS
G	 1/4*40mm	4 PCS

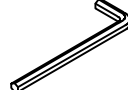

STEP 7
Schritt 7

A	 25*75mm	1 PCS
F		4 PCS

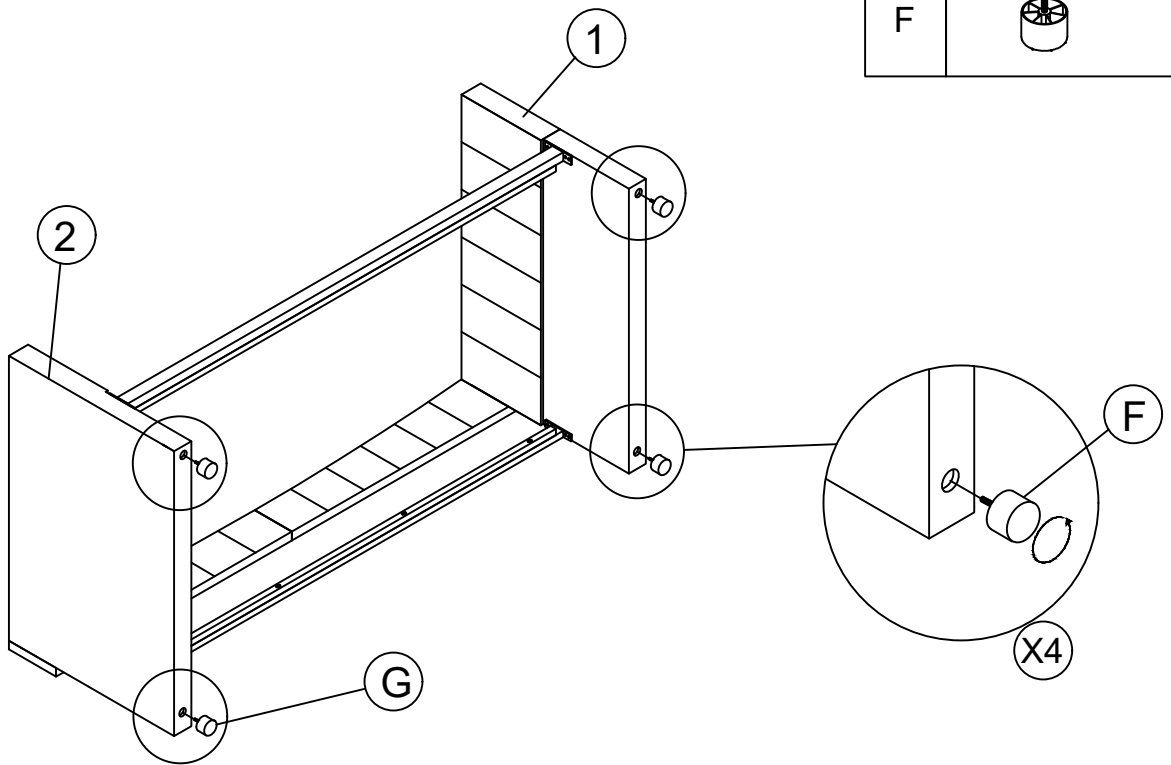

STEP 8
Schritt 8

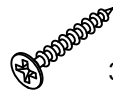

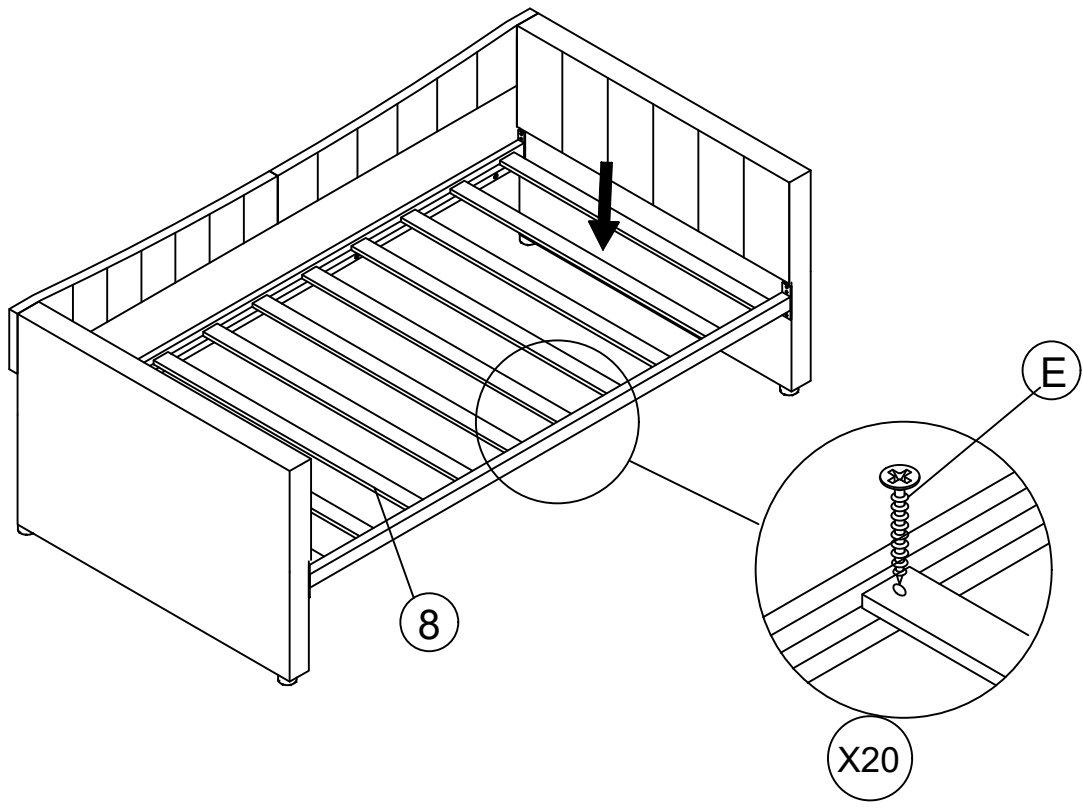
E	 3.5*30mm	20 PCS
---	--	--------



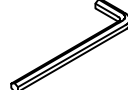
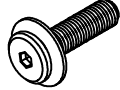

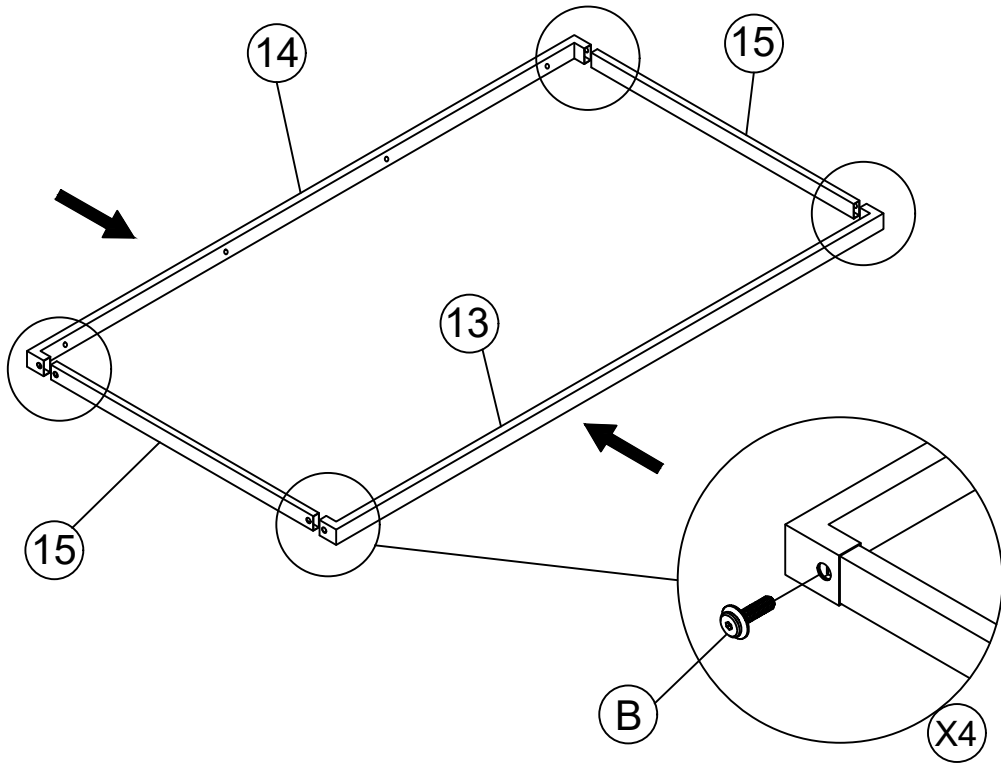
STEP 9
Schritt 9

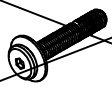
A	 25*75mm	1 PCS
B	 1/4*20mm	4 PCS





	1/4*40mm
	1/4*20mm

STEP 10
Schritt 10

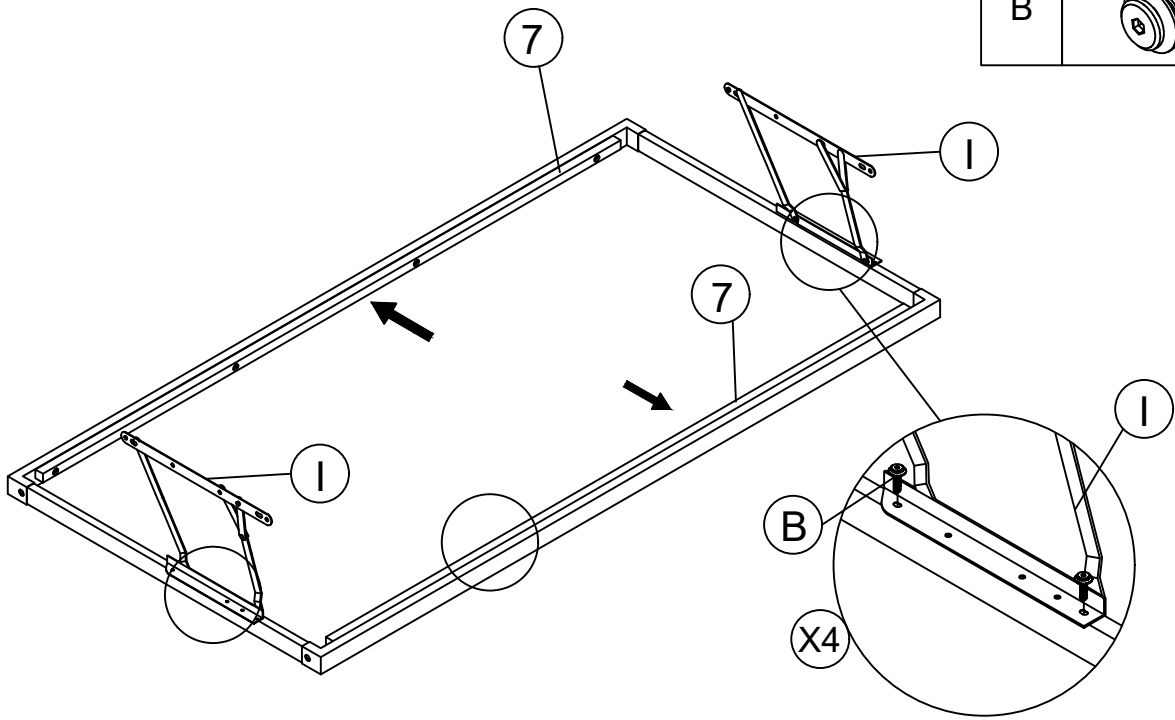
A	 25*75mm	1 PCS
B	 1/4*20mm	4 PCS

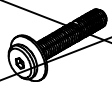

	1/4*40mm
	1/4*20mm

STEP 11
Schritt 11

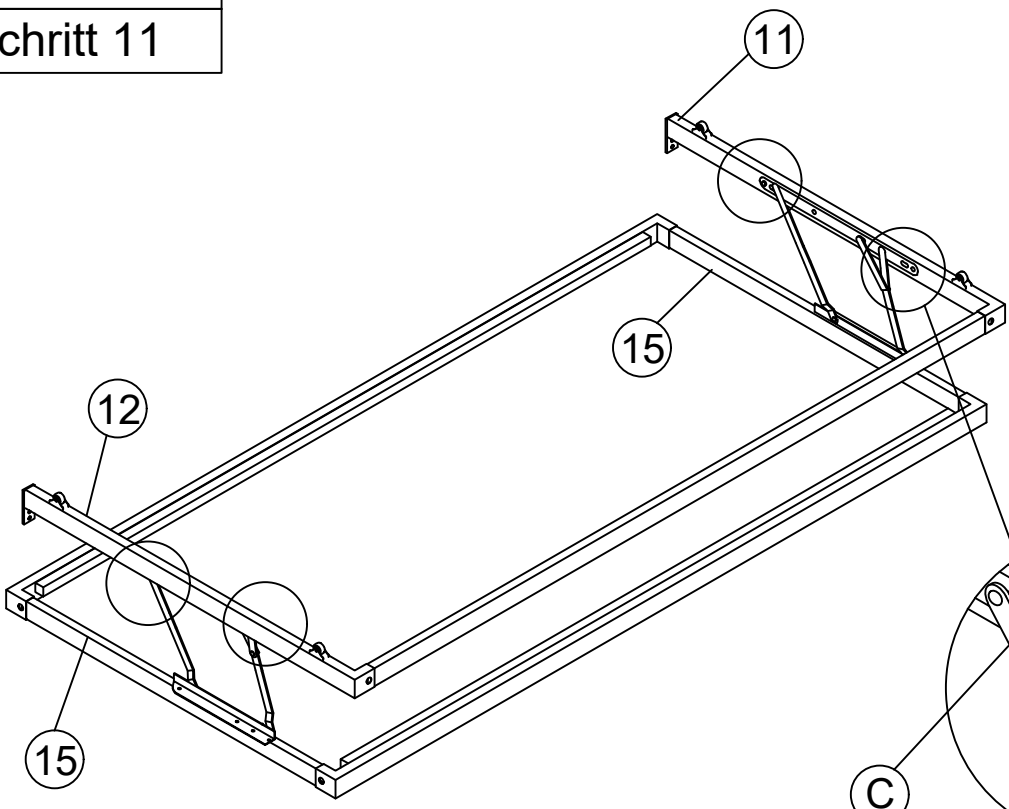

A	25*75mm	1 PCS
B	1/4*20mm	4 PCS

1/4*40mm
1/4*20mm

STEP 12
Schritt 12

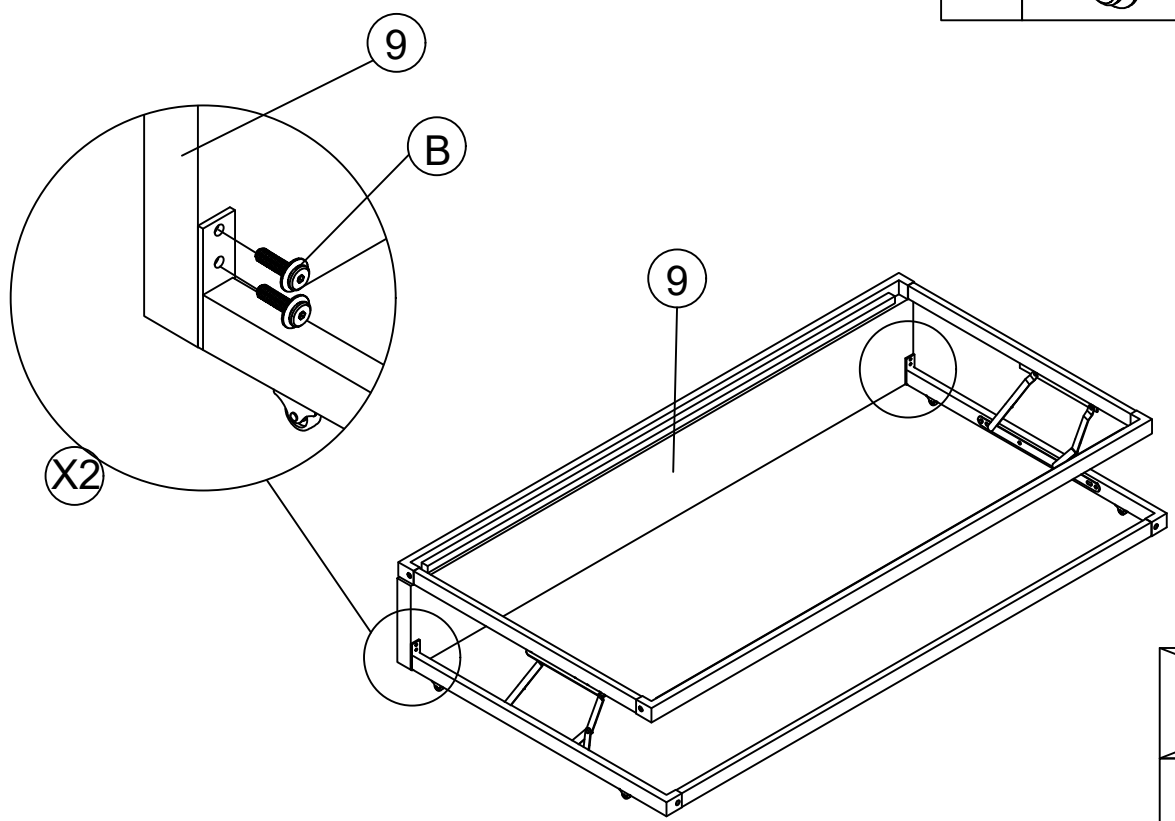

A	25*75mm	1 PCS
B	1/4*20mm	4 PCS

1/4*40mm
1/4*20mm

STEP 13
Schritt 13

E		3.5*30mm	20 PCS
---	--	----------	--------

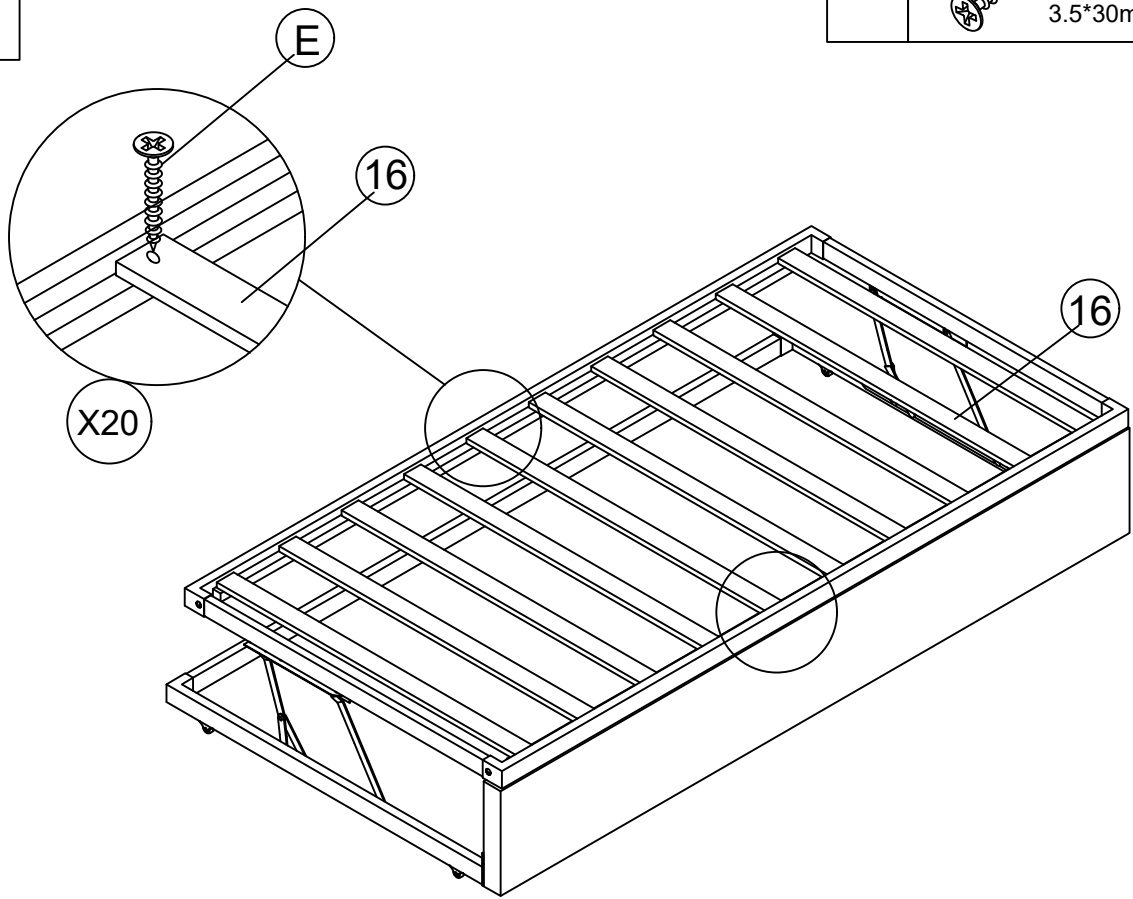

FINAL
FINALE

