

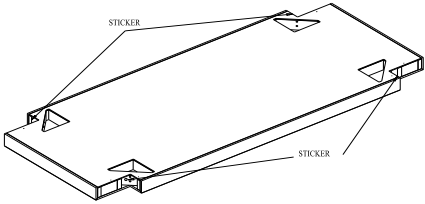
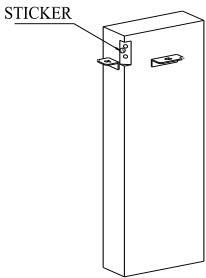
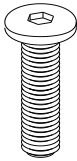
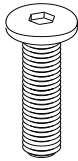
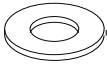

# ASSEMBLY INSTRUCTIONS

SKU# 51031716

## PARTS LIST

A	TABLE TOP X 1		<p><b>Before beginning</b></p> <ol style="list-style-type: none"> <li>Carefully unpack and position the item on a clean, non-marring surface to assemble.</li> <li>Read this Assembly Instructions from beginning to end before starting to assemble.</li> <li>Take an inventory of the required parts to ensure all are available.</li> <li>To prevent accidental choking hazards, keep all packing materials away from small children.</li> <li>Only tighten hardware until ALL hardware are fully engaged on their locations. Overtighten bolts will damage the bolt threads.</li> <li>Use only factory provided hardware to assemble. Unapproved hardware can damage product or jeopardize the structural integrity of the product.</li> <li>The use of power tool to assemble is not recommended due to high risk of over-torque, which can damage the product.</li> </ol>						
B	LEG X 4								

Z	HARDWARE	<p><b>Z1</b></p>  <p>8X80MM X 8</p>	<p><b>Z2</b></p>  <p>8X30MM X 8</p>	<p><b>Z3</b></p>  <p>8X19X1.6MM X 16</p>	<p><b>Z4</b></p>  <p>8X12X2MM X 16</p>	<p><b>Z5</b></p>  <p>Allen key X 1</p>			
---	----------	--	--	---	---	--	--	--	--

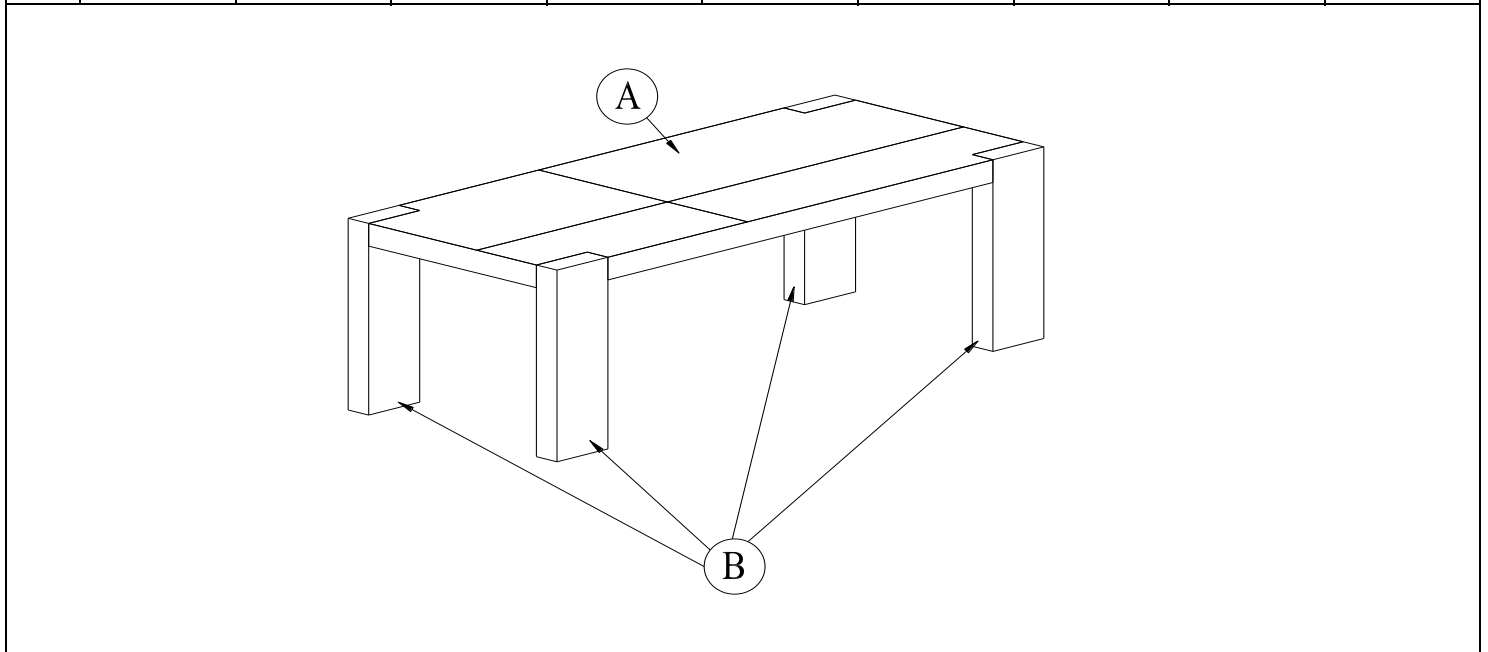

ASSEMBLY REQUIRES  
TWO PEOPLE



30-MINUTE  
ASSEMBLY TIME



KEEP INSTRUCTIONS  
FOR FUTURE USE



# ASSEMBLY INSTRUCTIONS

## SKU# 51031716

1

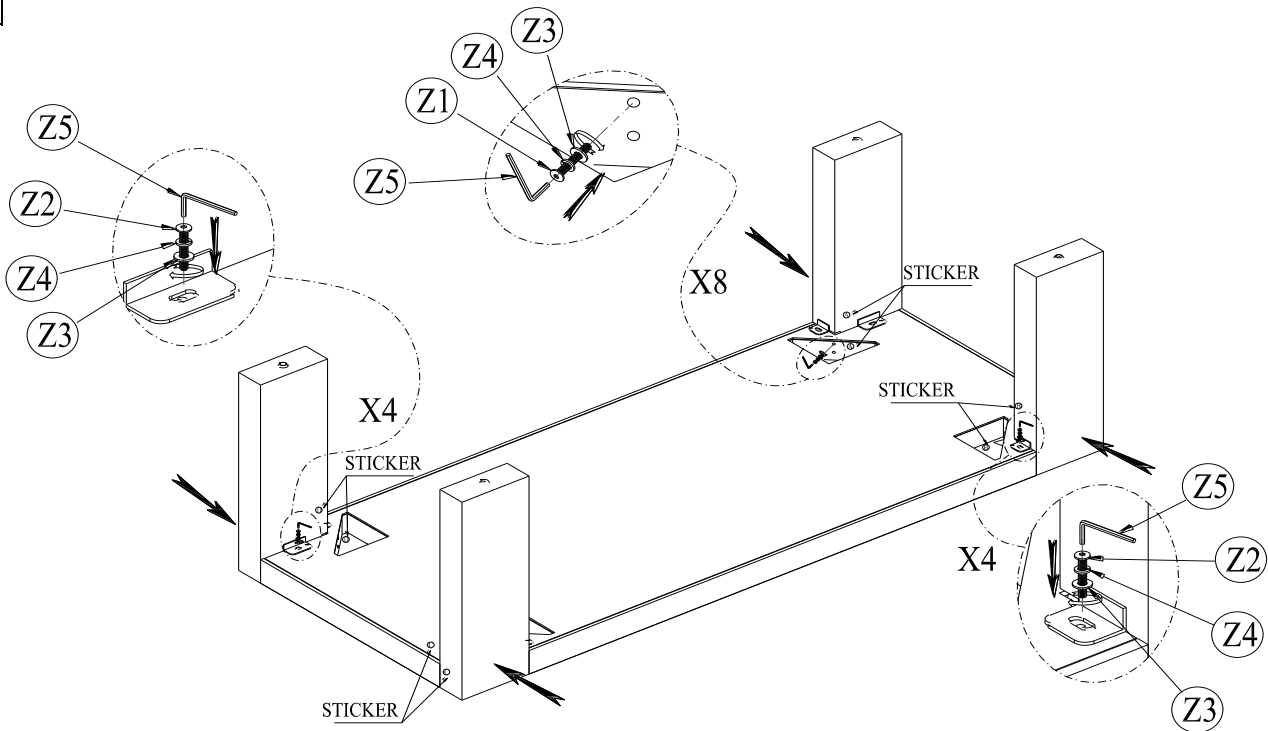

- Assemble the Legs (B) into the Table Top (A) as pictured. Tighten all Allen Bolts (Z1) and Allen Bolts (Z2), Spring Washers (Z4) and Washers (Z3) by using Allen Key (Z5).

2

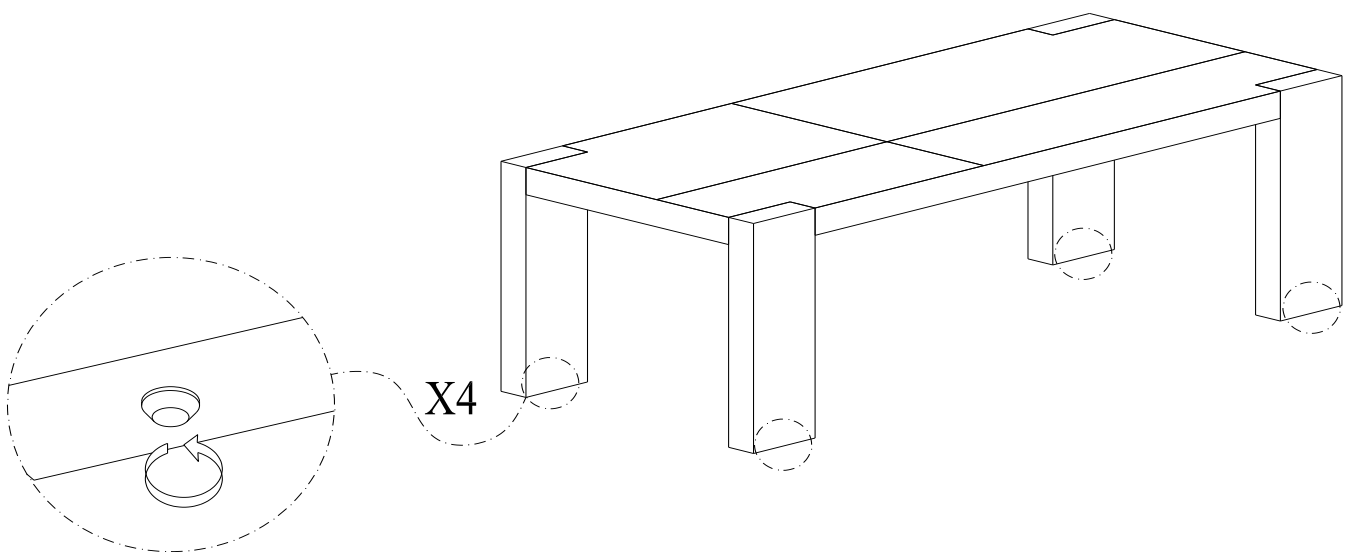

- With the assistance of two people, carefully flip the table over and position it on its legs.  
- If the table is not level, make adjustments by using the adjustable floor glides beneath the legs.  
- Assembly Completed