

WARNING

**** WE RECOMMEND INSTALLATION OF THIS LIGHTING FIXTURE BE DONE BY A LICENSED ELECTRICIAN ****

- * Switch off the main electrical supply from the main fuse box / circuit breaker before installation.
- * Inspect item carefully before attempting to install.
- * If there is any damages or obvious defects, do not install.
- * Item may not be returned once it has been installed.

CARE AND MAINTENANCE























- * To clean the outside of the fixture, use a dry or slightly dampened clean cloth (use clean water, never a solvent) to wipe the surface of the fixture.
- * To clean the inside of the fixture, first disconnect power to the fixture by turning off the circuit breaker or by removing the fuse at the fuse box. Next, use a dry or slightly dampened clean cloth (use clean water, never a solvent) to wipe the interior surface of the fixture.
- * Do not use any cleaners with chemical, solvents or harsh abrasives. Use only a dry soft cloth to dust or wipe carefully.

NOTICE& IMPORTANT SAFETY INSTRUCTIONS

- * Please make sure that you have all parts indicated before you begin assembly of this item
- * This item should be assembled on a soft surface to prevent scratching the finish during assembly
- * To reduce the risk of fire, electrical shock or injury to persons or property, please follow the guideline below for safe use and installation
- *The external flexible cable or cord of this lamp cannot be replaced
If the cord is damaged, the lamp shall be destroyed

Product Dimensions: 26"L X 26"W X 18"- 48"H

Part List and Hardware List

PIECE	DESCRIPTION	PICTURE	QUANTITY	PIECE	DESCRIPTION	PICTURE	QUANTITY
A	Hex nut		3X	N	Canopy		1X
B	Metal washer		1X	O	6"Rod		2X
C	Threaded rod		1X	P	12"Rod		2X
D	Teeth washer		1X	R	Fixture body		1X
E	Wire Nut		3X				
F	Mounting bracket		1X	S	Light bulb		6X
G	Plain washer		2X	T	Crystal glass		12X
H	Outlet box screw		2X	U	Large spanner		1X
I	Small spanner		1X	V	Set screw		12X
J	Swivel		1X	W	Banding metal Plate		12X
L	Cluster		1X	X	spare EVA pad		5X
M	Buckle		2X				

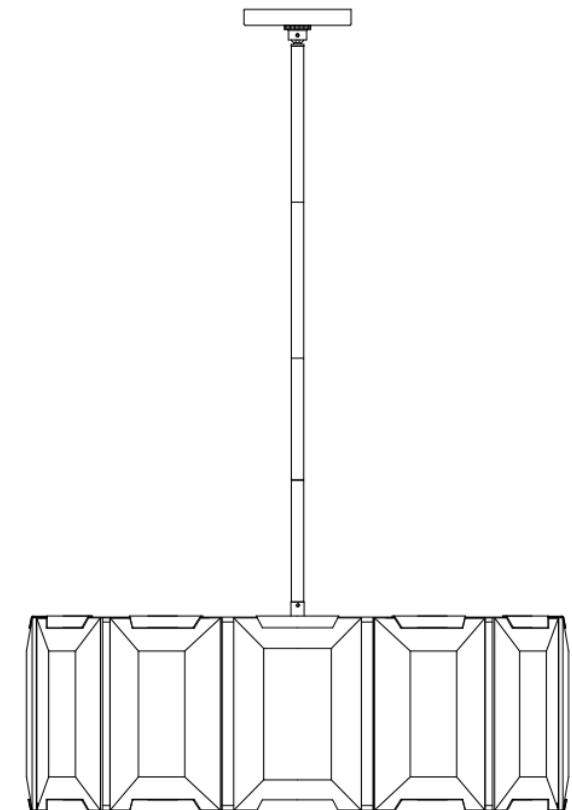

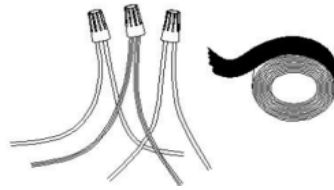
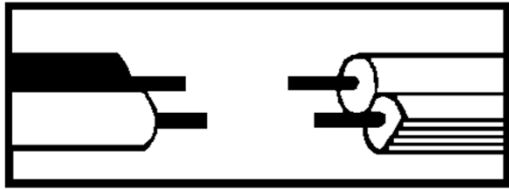

Step 3: Wire connection

Connect fixture neutral wire (ribbed) to the outlet box neutral wire (usually white) using a wire nut. Connect fixture hot wire (smooth with markings) to the outlet box hot wire (usually black) using a wire nut.

CAUTION: Do not reverse the hot and neutral connections

Grounding Instructions:

Wrap ground wire from outlet box around green ground screw(B) on mounting bracket, no less than 2" from wire end. Tighten ground screw. If fixture is supplied with a ground wire, connect to outlet ground wire with a wire connector.

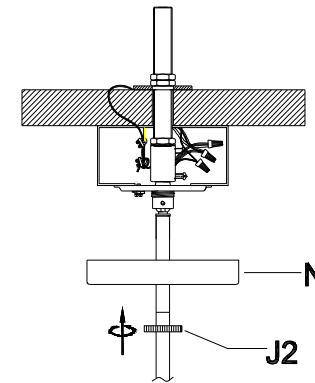

Step 4: Attach the canopy (N) to the ceiling with canopy ring (J2).

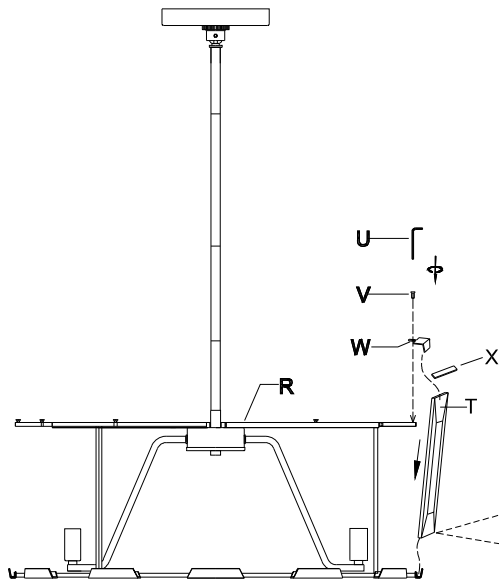

X — 
 TIPS: When assembling the crystal glass, you can attach the EVA pad (W) to the clips on the top and bottom to make the crystal glass more firm

Step 5: Install the crystal glass (T) to the groove or fixture body (R), fix with banding metal plate (W), finally secure with set screw (V) by using the large spanner (U).

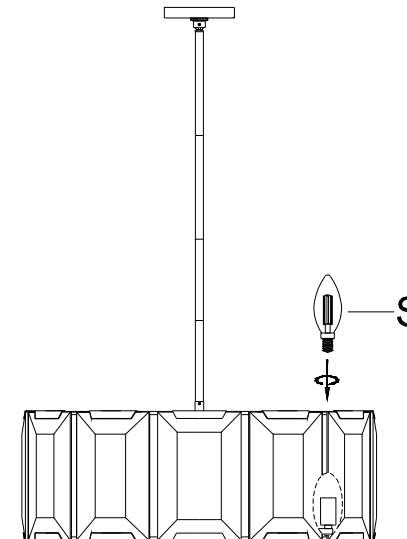

Step 6: Install the light bulb (S) to the socket.