

NOTICE

- *Please make sure that you have all parts indicated and they are in good condition before you begin assembly of this item. Refer to part list and hardware list below for guidance.
- *This item should be assembled on a soft surface to prevent scratching the finish during assembly.
- * This item may require periodic tightening.
- *If you are having difficulty , our friendly Customer Care team is always here to help.

Product Dimensions:

25.5" W x 24" D x 30" H









PREPARATION

- *Before beginning assembly of product , make sure all parts are present . Compare parts with part contents list and hardware contents list.
- *If any part is missing or damaged , do not attempt to assemble the product.
- *Estimated Assembly Time: 10 minutes.
- *Tolls Required for Assembly (included) : Allen Key

CARE AND MAINTENANCE

- *Spot clean using a mild water-free solvent.
- * Only a professional cleaner should undertake a complete overall cleaning.
- *The use of steam or water-based cleaners may cause excessive shrinking or staining.

Part List and Hardware List

PIECE	DESCRIPTION	PICTURE	QUANTITY
A	Backrest		1X
B	Seat Body		1X
C	Seat Cushion		1X
D	Left Arm		1X
E	Right Arm		1X
HW1	Allen Bolt: M8 x1.25 x 50 mm		7X
HW2	Spring Washer : M8		7X
HW3	Flat Washer : M8x22mm		7X
HW4	Allen Key		1X

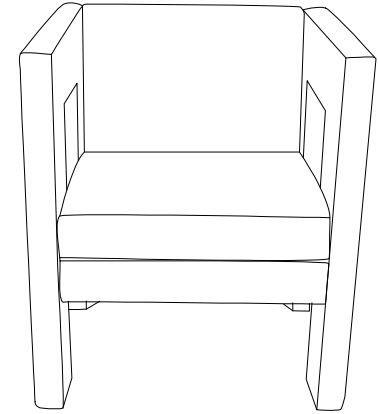

Weight Capacity: 275 lbs

WARNING: DO NOT STAND ON CHAIR

WARNING: DO NOT OVER TORQUE BOLTS/SCREWS

PREPARATION

*Before beginning assembly of product , make sure all parts are present . Compare parts with part contents list and hardware contents list.

*If any part is missing or damaged , do not attempt to assemble the product.

*Estimated Assembly Time:10 minutes.

*Tolls Required for Assembly (included) : Allen Key

*If you are having difficulty , our friendly Customer Care team is always here to help.

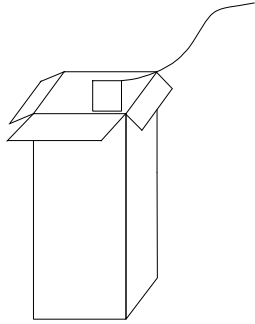

STEP1: TAKE OUT HARDWARE FROM THE SMALL BOX .

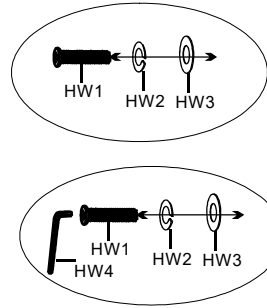

STEP 2: PUT THE WASHERS ON THE BOLT IN THE ORDER SHOWN AS THE PICTURE.

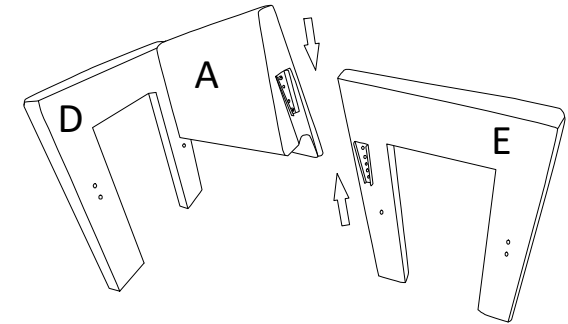

STEP 3: INSERT LEFT ARM (D) AND RIGHT ARM (E) ONTO BACK (A) AS PICTURE SHOWN.

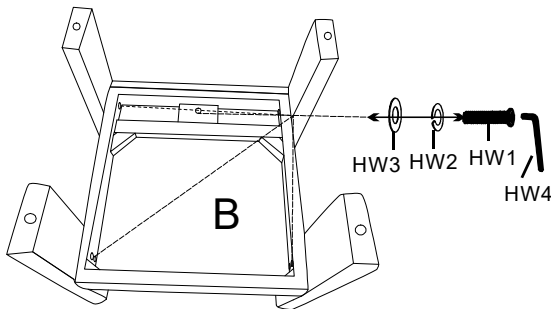

STEP 4: PALCE THE CHAIR UPSIDE DOWN, PUT SEAT BODY (B) ONTO THE CHAIR AND SCREW IN THE BOLTS . BUT DON'T TIGHTEN COMPLETELY.

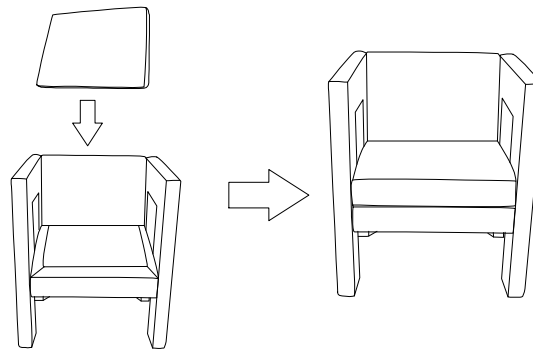

STEP 5 : PUT THE CHAIR UPRIGHT AND MAKE SURE ALL LEGS ARE LEVEL, THEN FIRMLY TIGHTEN BOLTS WITH ALLEN KEY WHILE THE CHAIR IS UPRIGHT AS PICTURED ABOVE. THEN PUT THE SEAT CUSHION (C) ON SEAT.

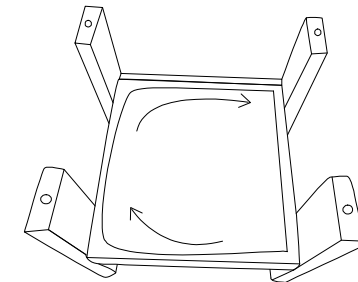

STEP 6 : ZIP THE COVER ON BOTTOM OF SEAT. THIS ITEM MAY REQUIRE PERIODIC TIGHTENING.