

General Assembly Guidelines

1. Ensure that all parts and hardware are available before beginning assembly.
2. Follow each step carefully to ensure the proper assembly of this product.
3. Two people are recommended for ease in the assembly of this product.
4. The three main types of hardware used to assemble this product are: wood dowels, screws and bolts.
5. A Philips head screwdriver is required for the assembly of this product.

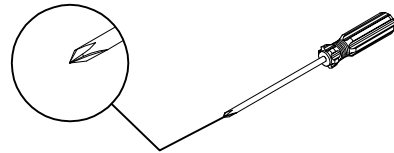

6. Power tools should not be used to assemble this product.

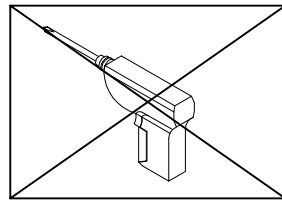

7. Drill may be needed for securing product to wall.

Parts List

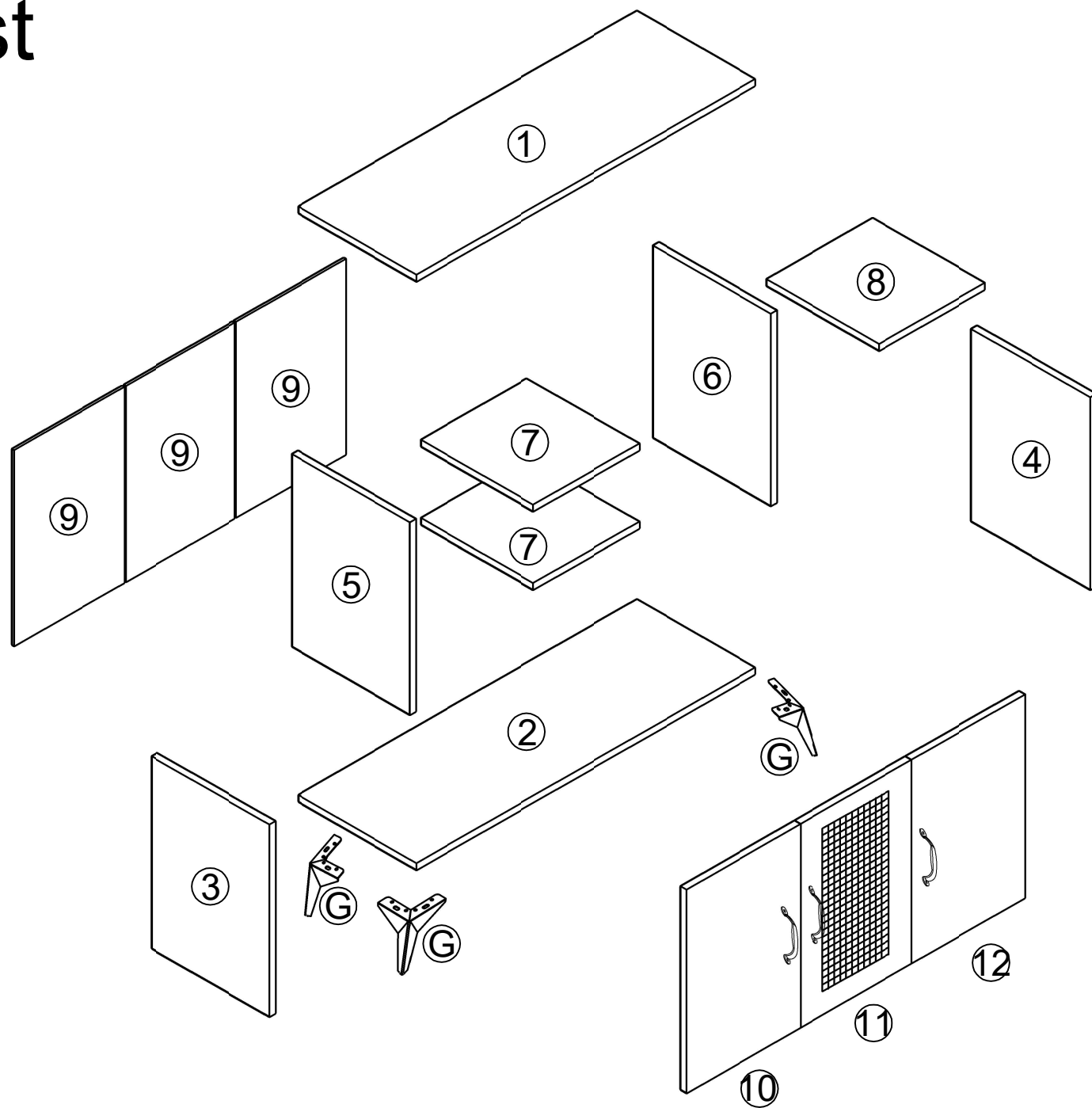

Hardware List

A.		Φ6X32mm	Cam bolt	28	PCS
B.		Φ15X11mm	Cam lock	28	PCS
C.		Φ8X30mm	Wooden dowel	28	PCS
D.		Φ3X15mm	Screw	56	PCS
E.			Hinge	2	PCS
F.			Hinge	4	PCS
G.		120mm	Legs	4	PCS
H.		120mm	Legs	1	PCS
I.		96mm	Handle	3	PCS
K.		Φ4X22mm		6	PCS

1

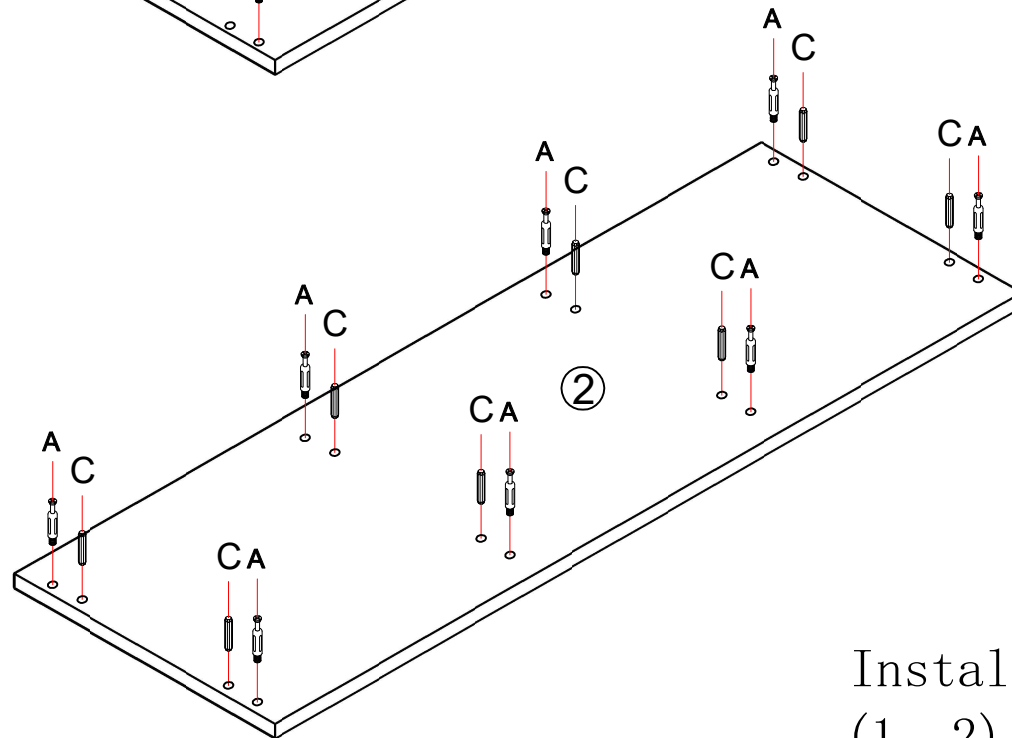
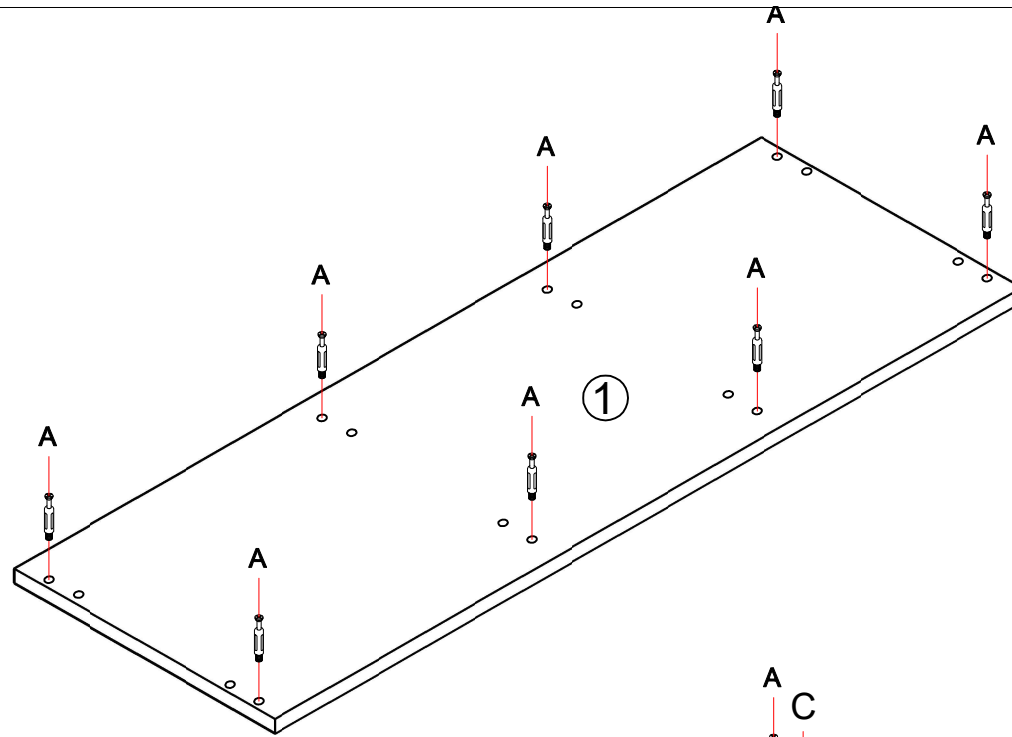

Install (A, C) onto plates (1, 2).

2

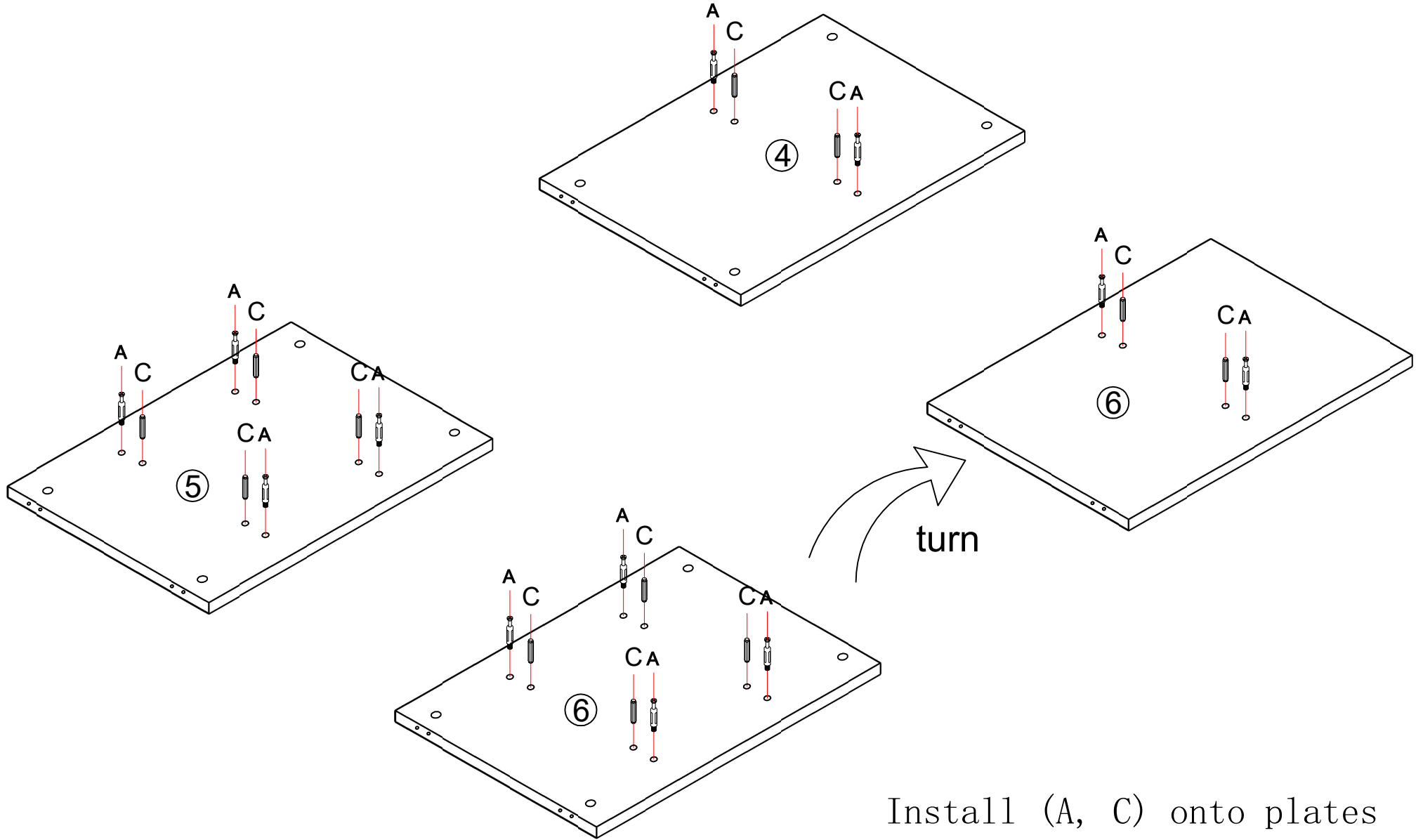

Install (A, C) onto plates
(4, 5, 6).

3

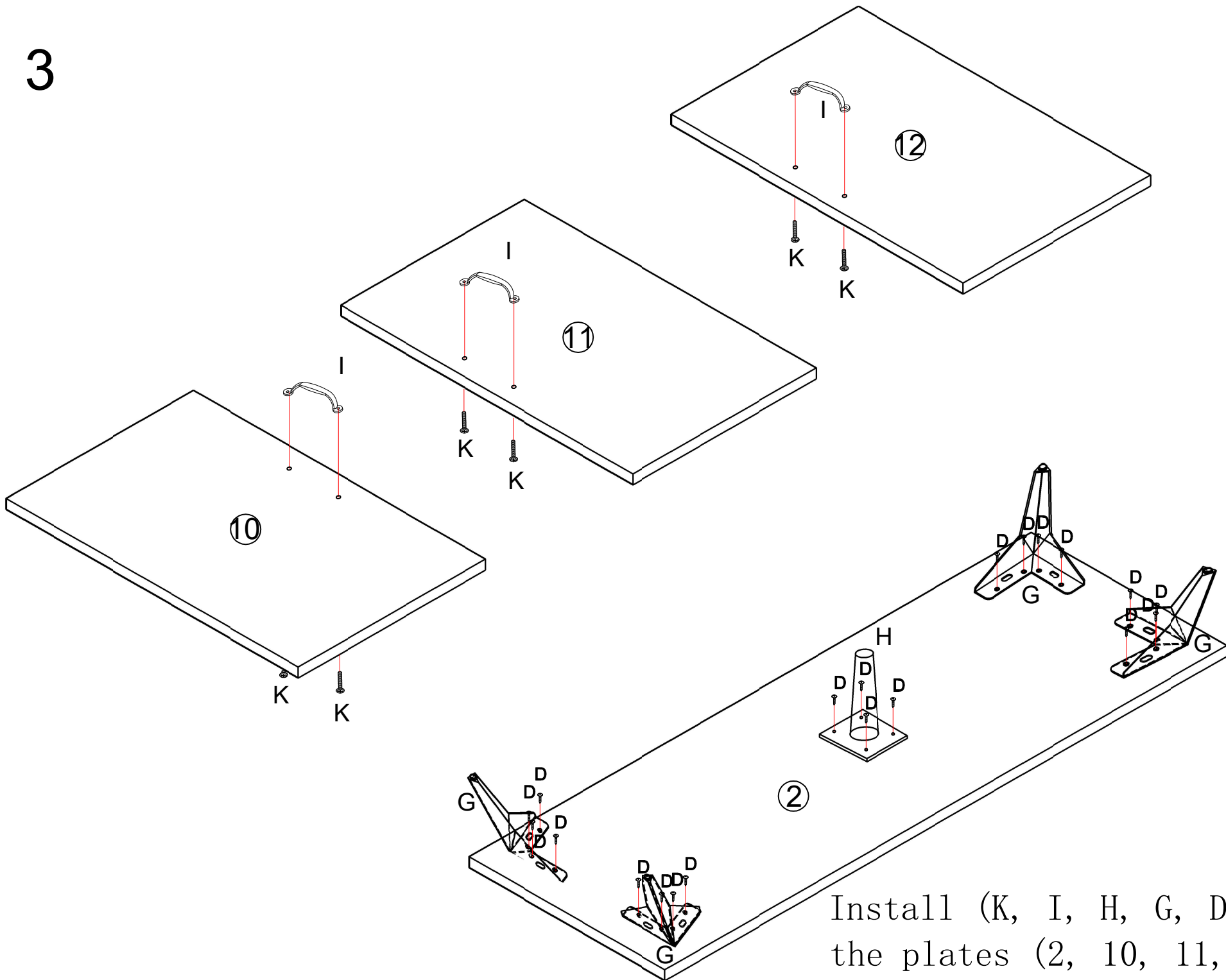

Install (K, I, H, G, D) onto the plates (2, 10, 11, 12).

4

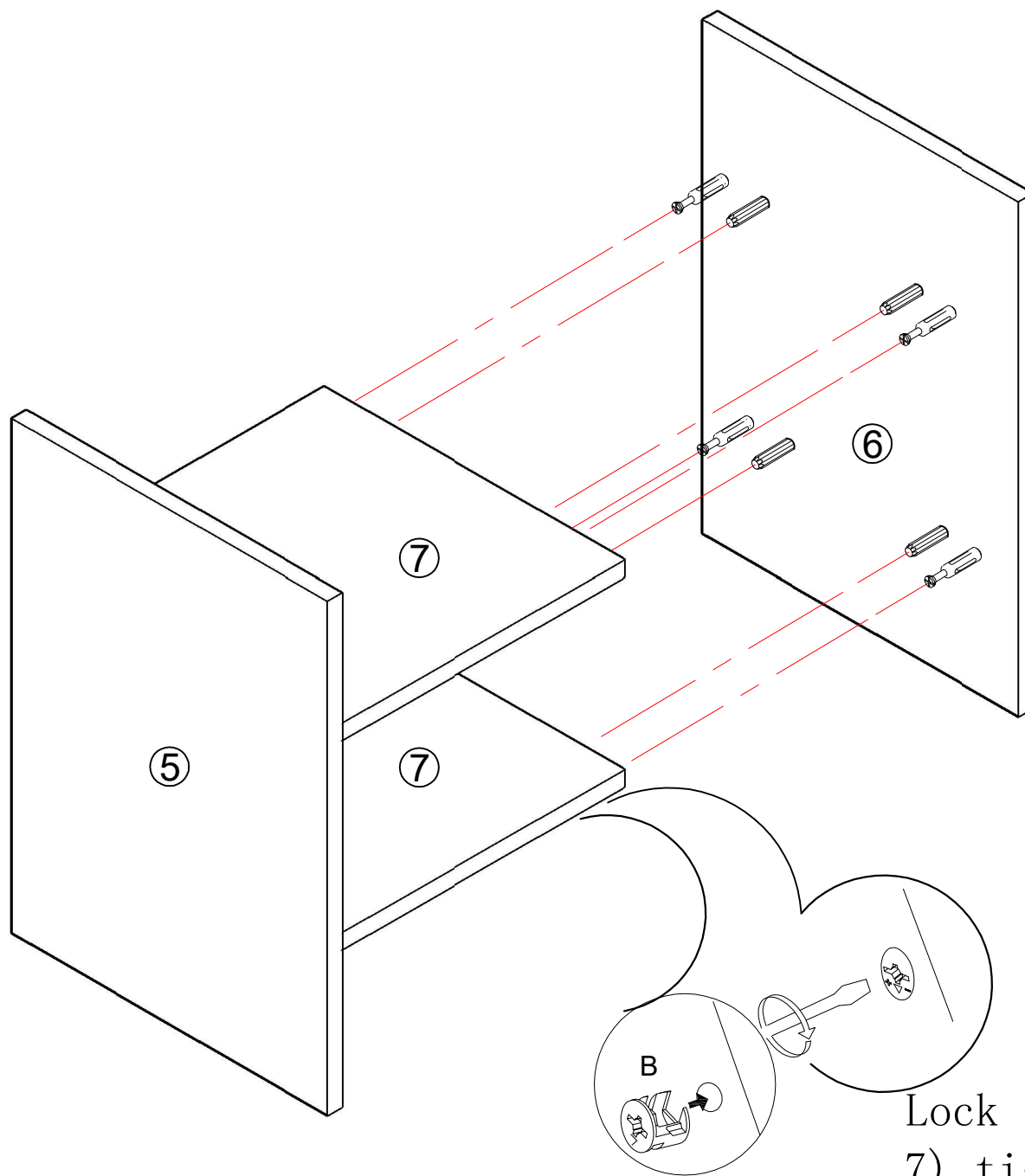

Lock the plate (5, 6, 7) tightly with (B).

5

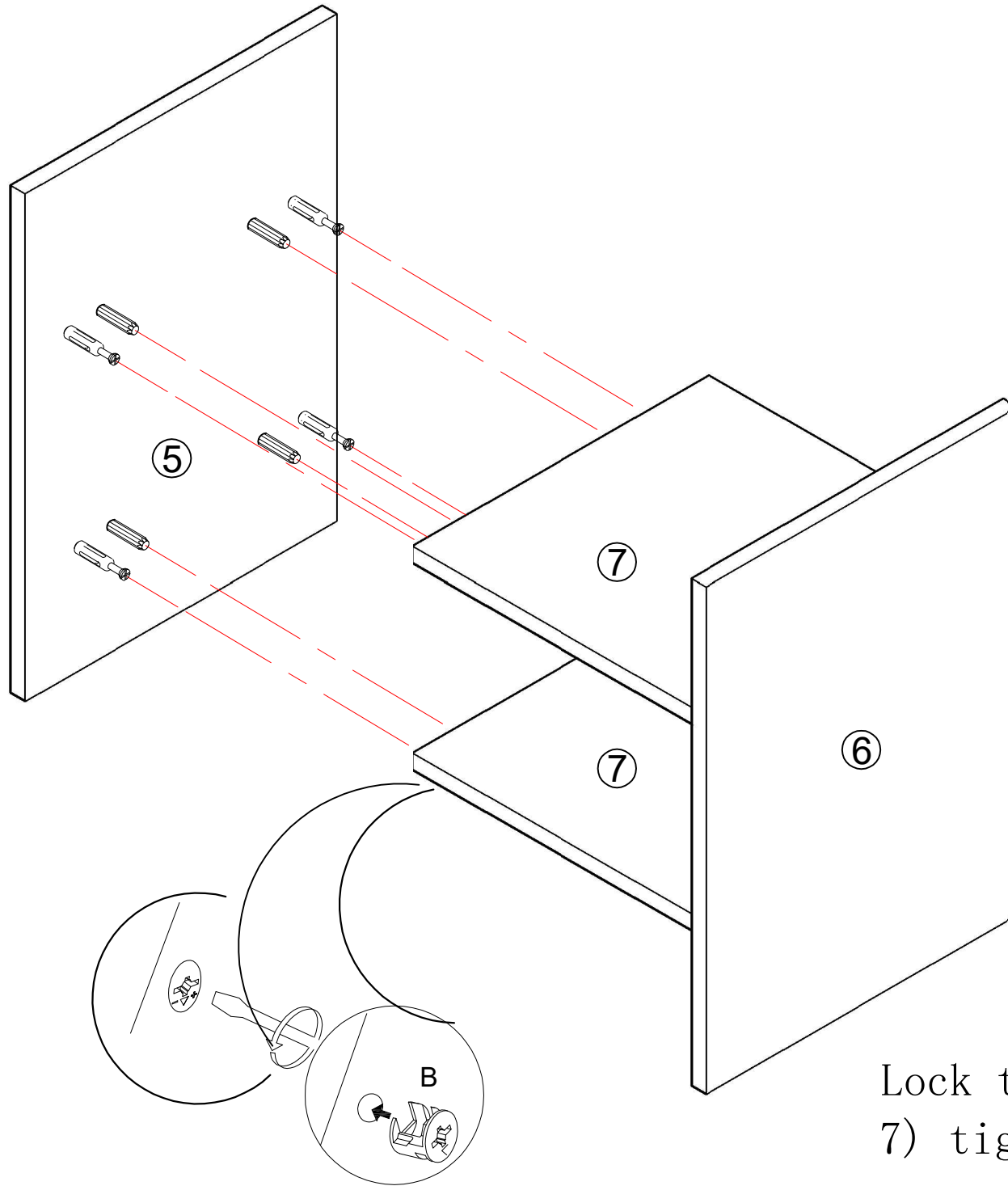

Lock the plate (5, 6, 7) tightly with (B).

6

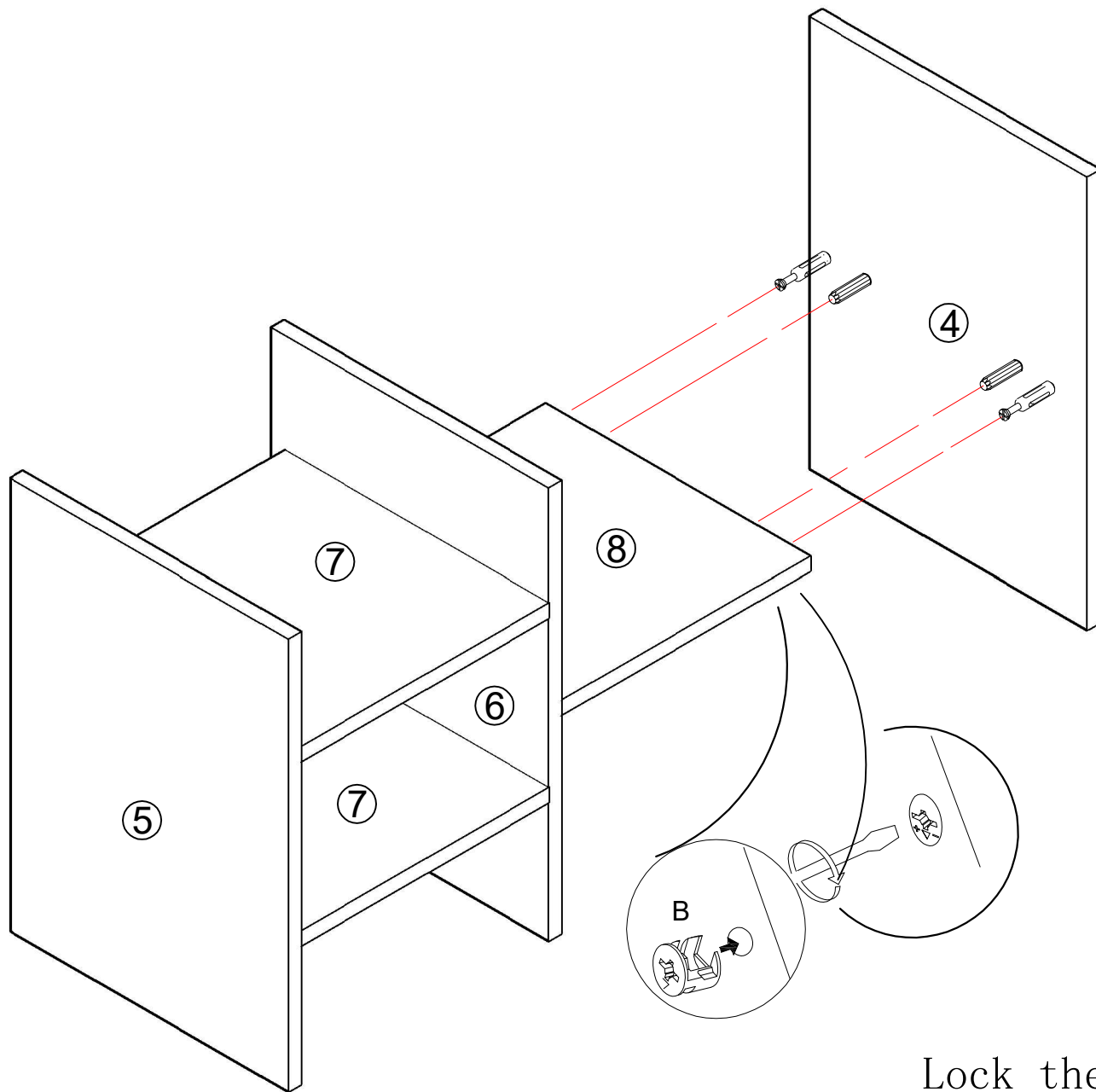

Lock the plate (4, 6, 8) tightly with (B).

7

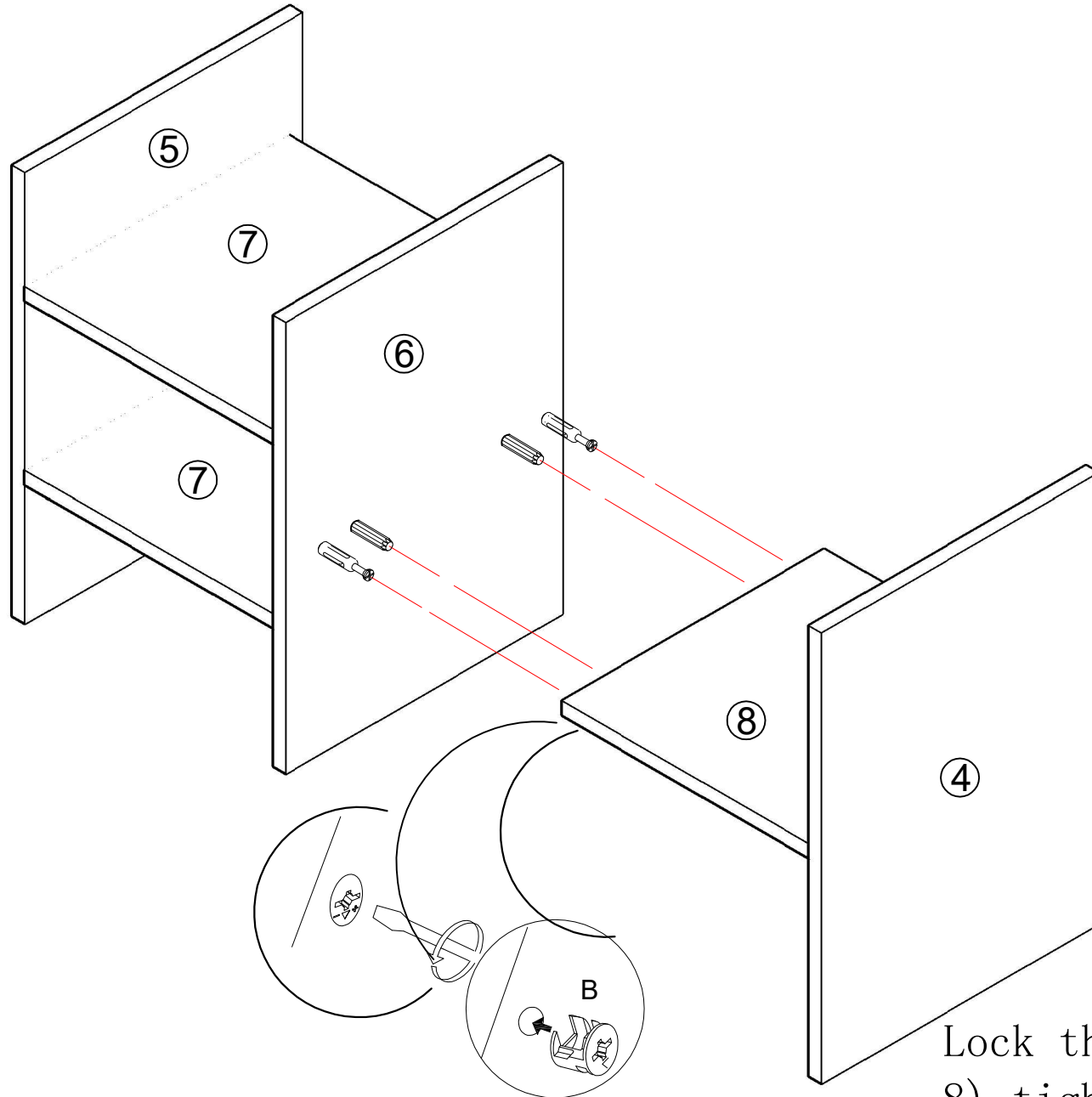

Lock the plate (4, 6, 8) tightly with (B).

8

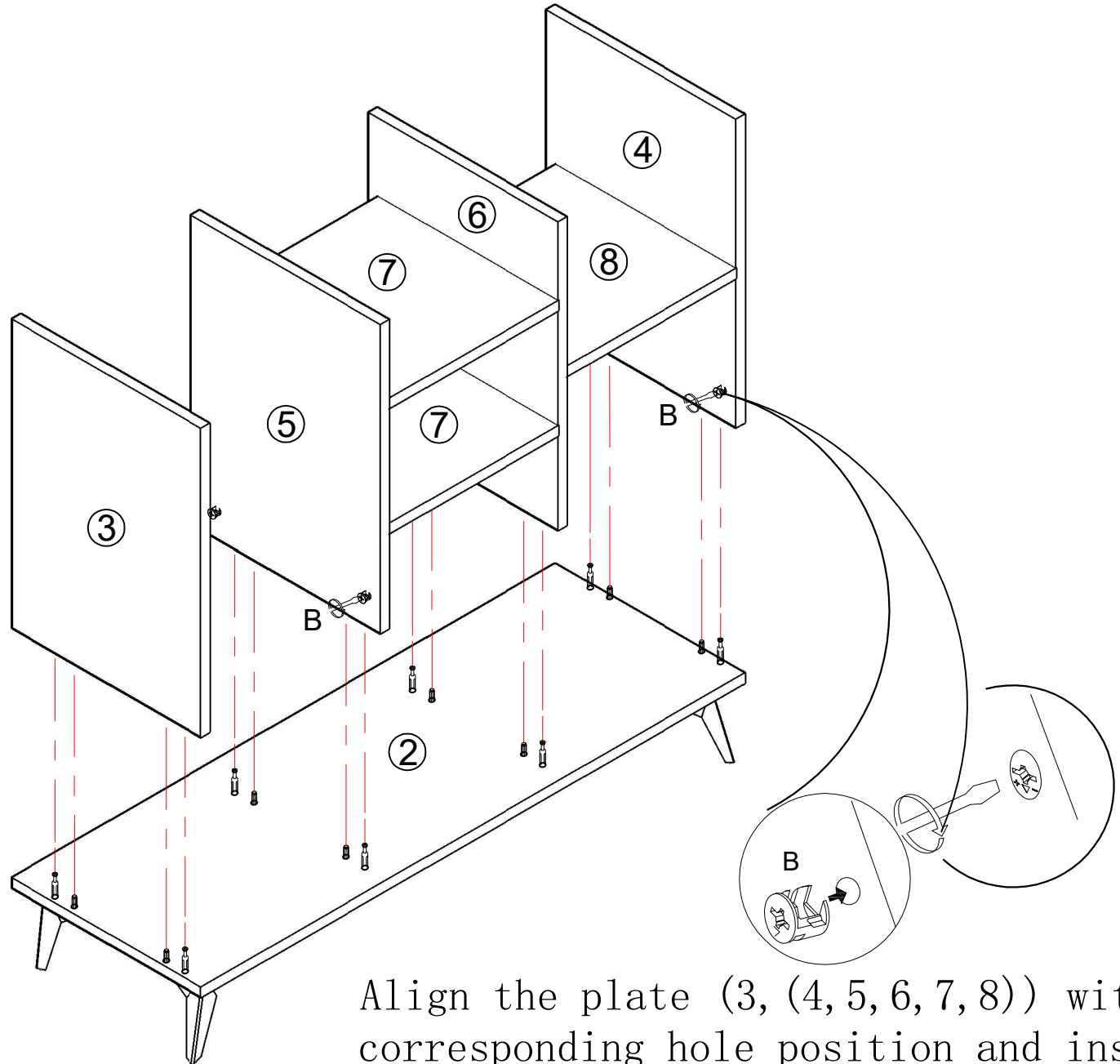

Align the plate (3, (4, 5, 6, 7, 8)) with the corresponding hole position and insert it into the plate (2).

9

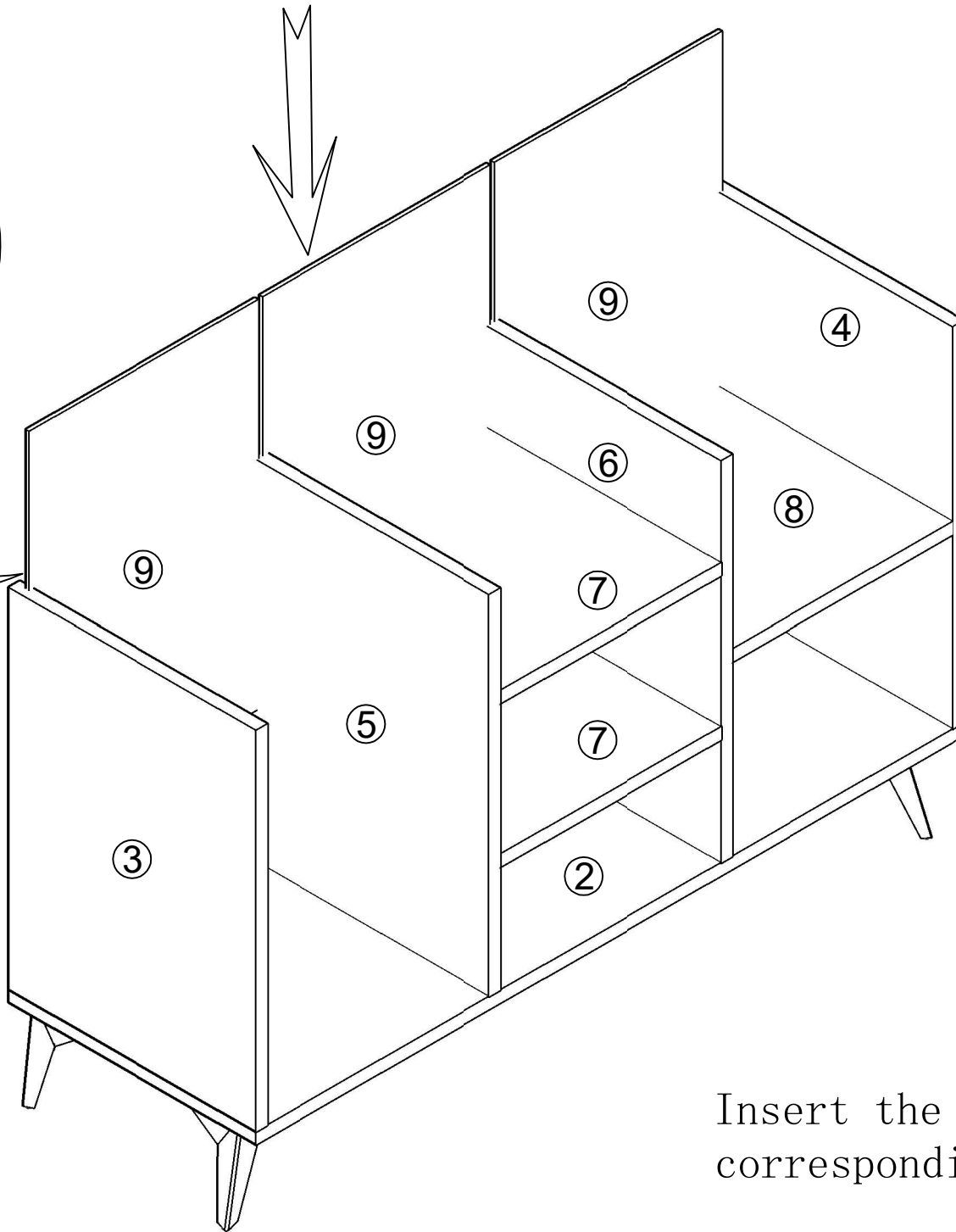
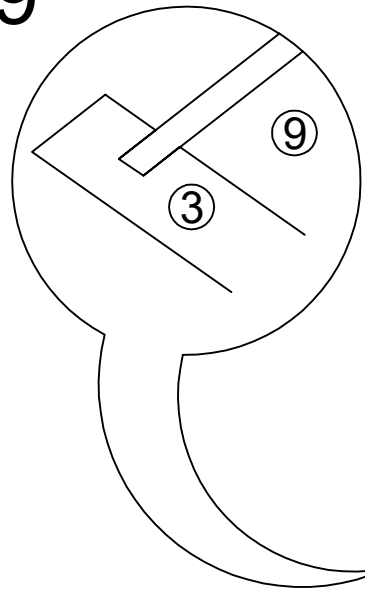

Insert the plate (9) into the corresponding slot

10

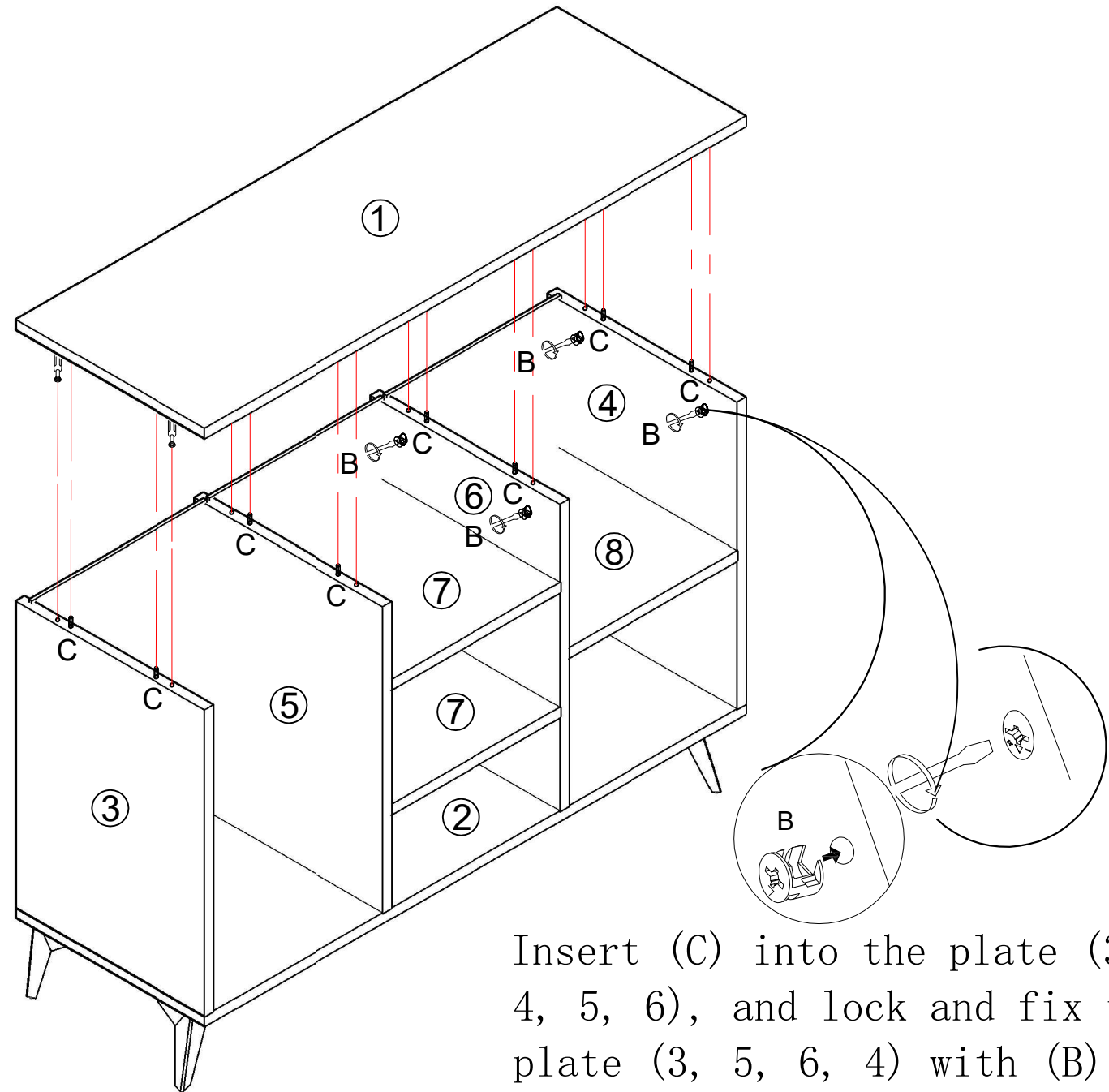

Insert (C) into the plate (3, 4, 5, 6), and lock and fix the plate (3, 5, 6, 4) with (B) and the plate (1).

11

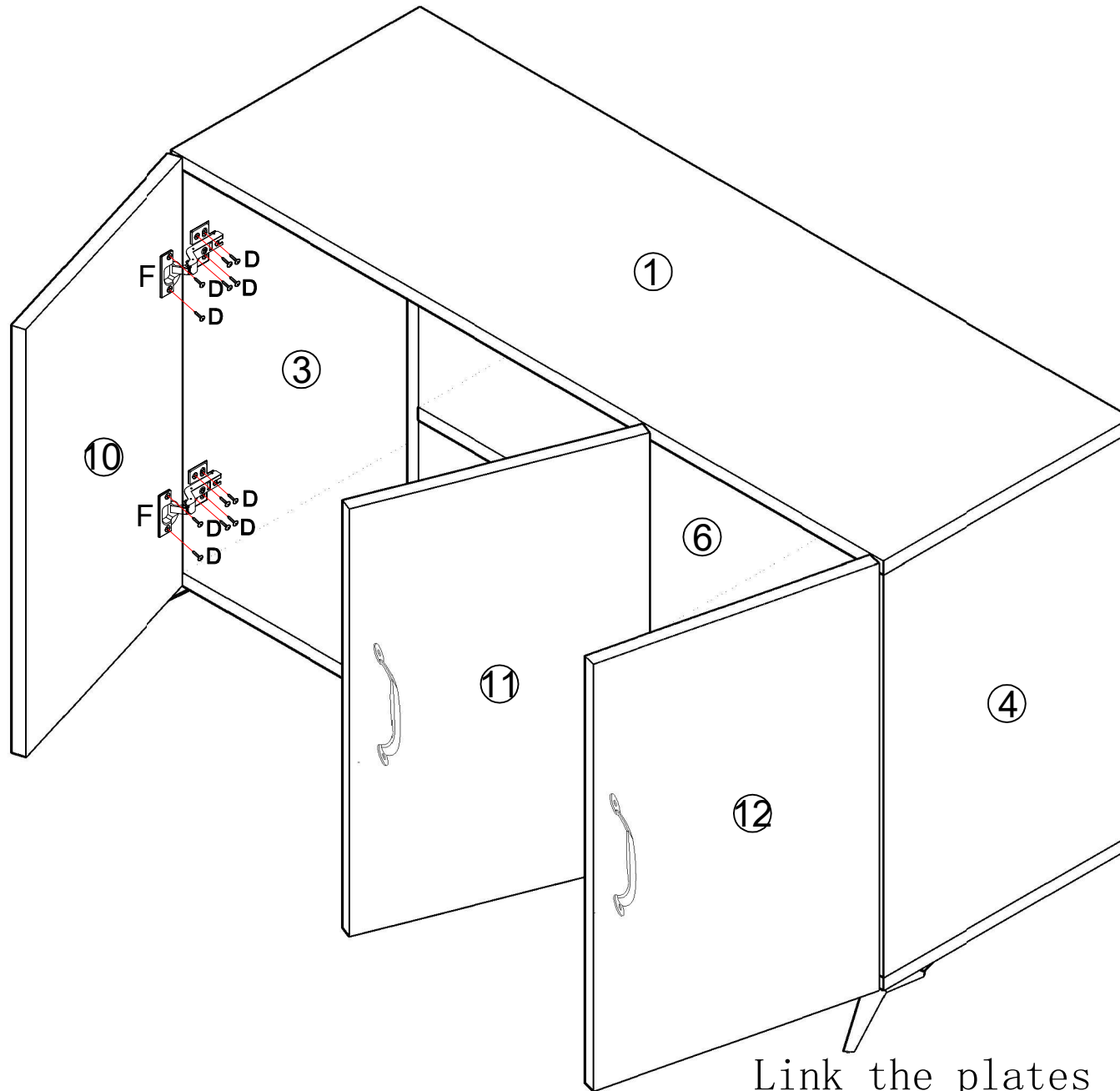

Link the plates (3, 10) with (F, D).

12

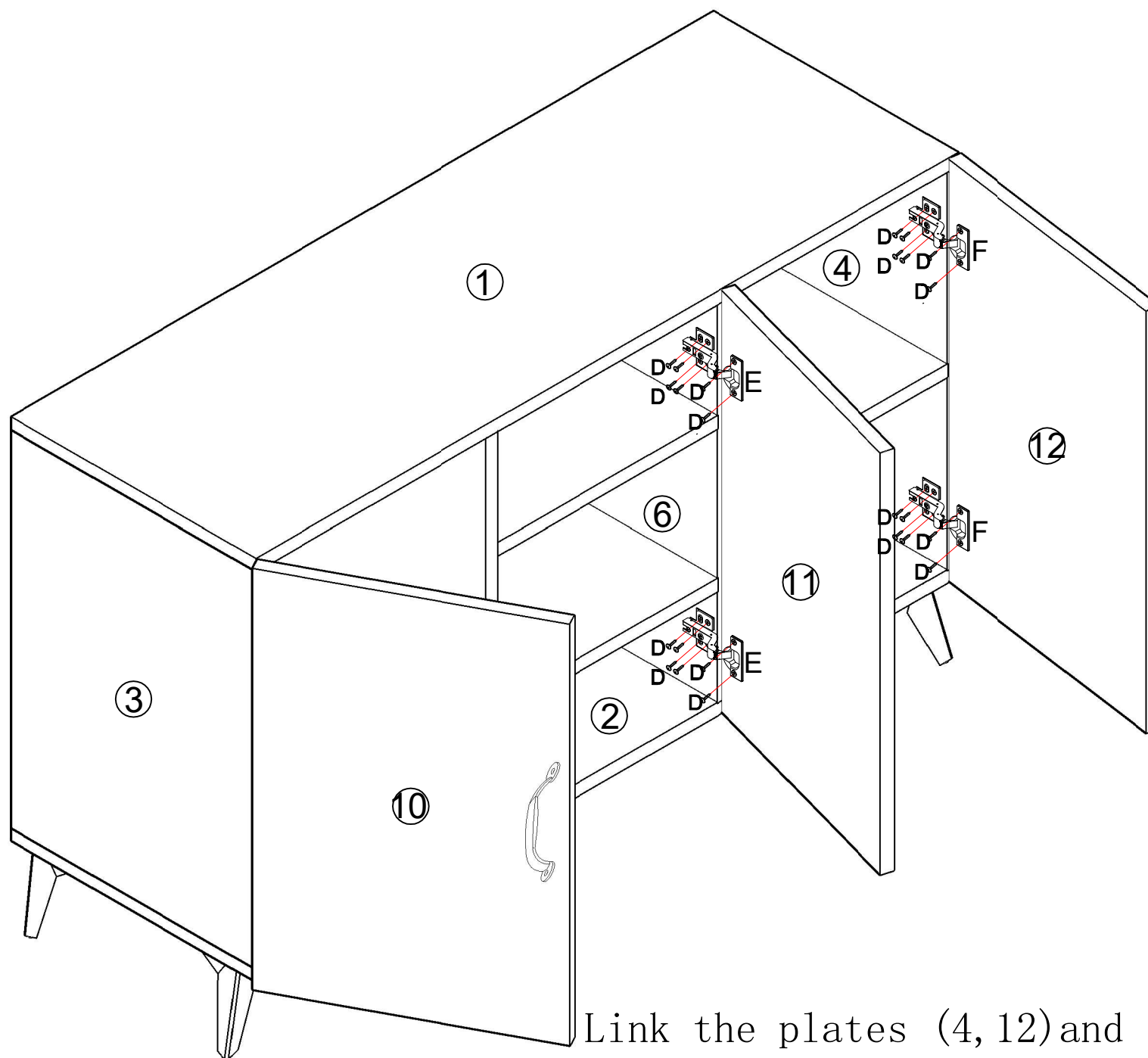

Link the plates (4, 12) and (6, 11) with (F, D) and (E, D).

13

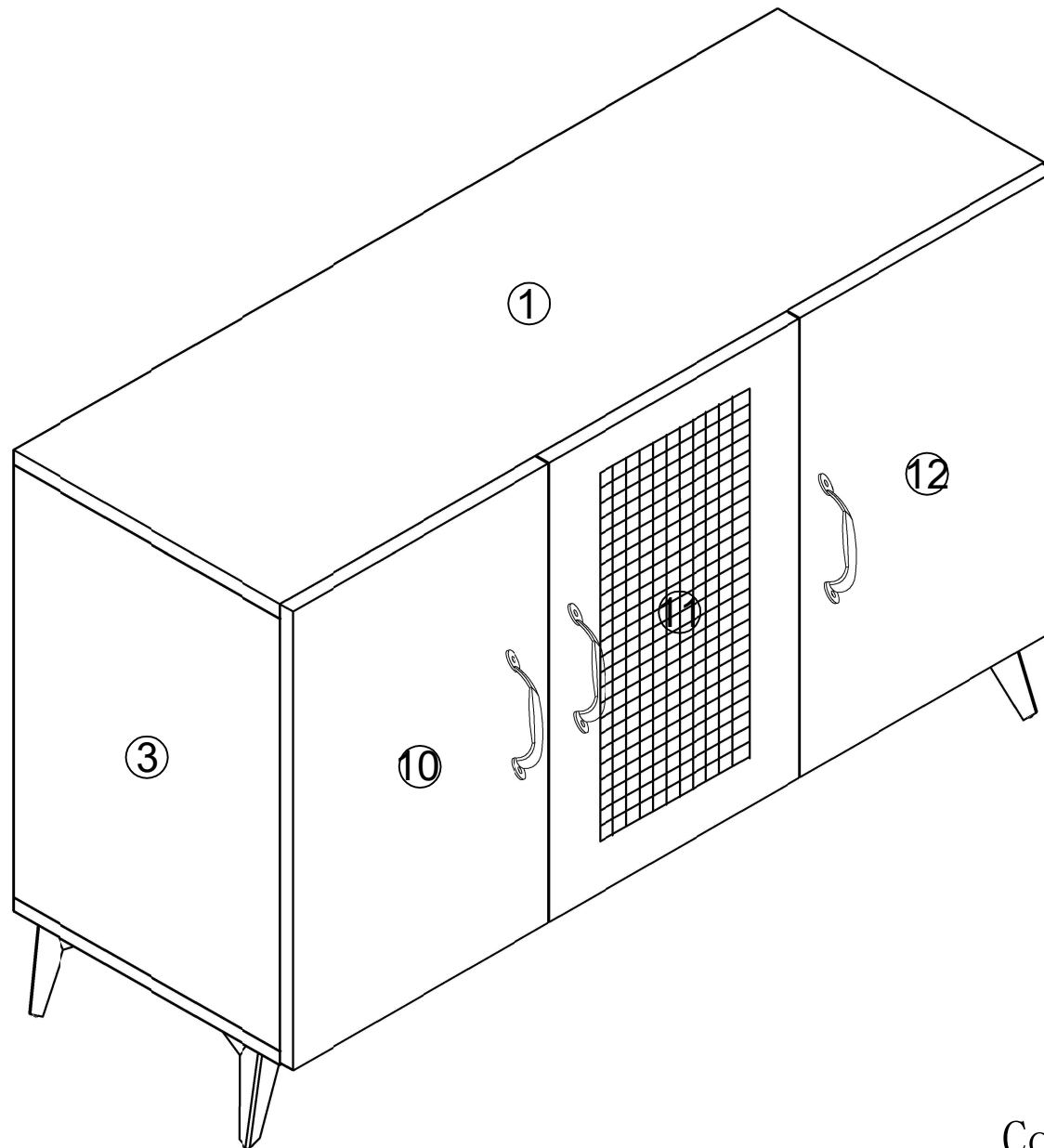

Complete the assembly