

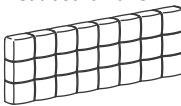





UPHOLSTERY HEADBOARD

Full/Queen Size

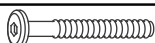
Examine all packaging material for small parts that may have come loose during shipment. Periodic checks are recommended to insure that all components are in proper position, tight and free from damage. Keep this assembly instruction for future reference. Adult assembly is required.

CODE	QTY	COMPONENTS	CODE	QTY	COMPONENTS
A	1	Headboard Panel 	B	2	Leg Extension 

CODE	QTY	HARDWARE
C	6	M6 x 40 Allen Bolts 
D	4	M6 x 50 Allen Bolts 
E	10	Spring Washers 
F	14	Flat Washers 
G	4	Hex Nuts 
H	1	Allen Wrench 

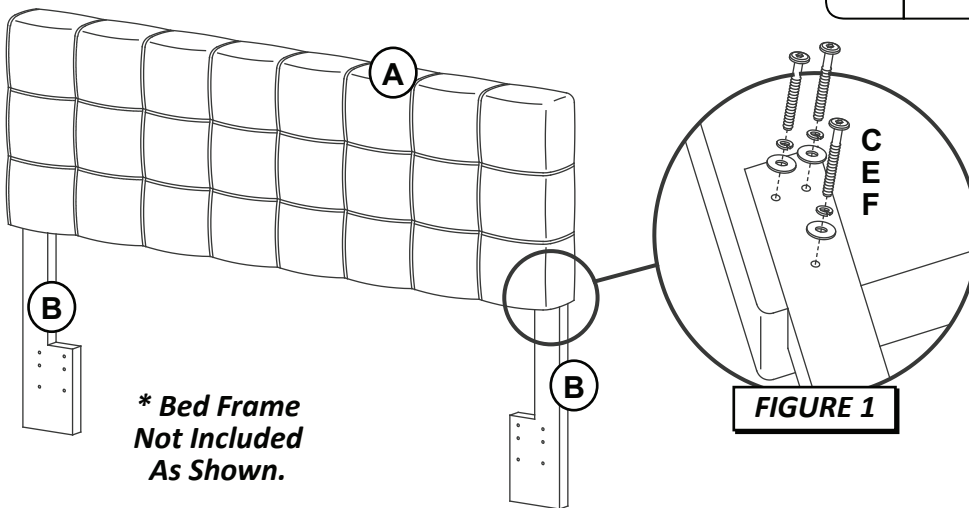

STEP 1 - Figure 1

Begin by assembly each Leg Extension (B) to the back of the Headboard Panel (A) using 3 Allen Bolts (C), 3 Spring Washers (E) & 3 Flat Washers (F) per each side. Tighten all bolts using the Allen Wrench (H) that has been provided.

** Bed Frame Not Included As Shown.*

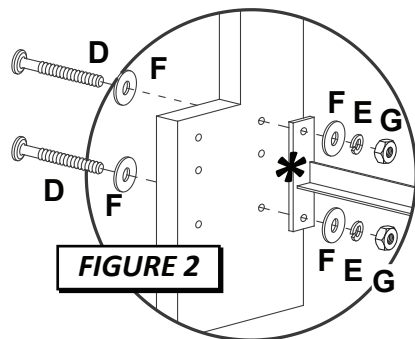

STEP 2 - Figure 2 (For Queen Size Assembly)

Next attach the bed frame (*Not Included) to each Leg Extension (B) by using 2 Allen Bolts (D) and 2 Flat Washers (F) from the back and 2 Flat Washers (F), 2 Spring Washers (E) and 2 Hex Nuts (G) from the front. Tighten all bolts.

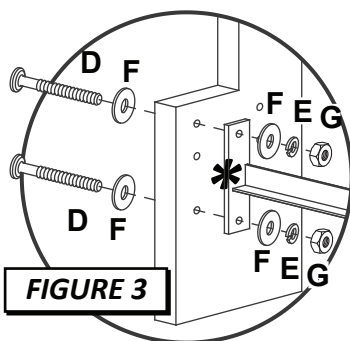

STEP 2 - Figure 3 (For Full Size Assembly)

Next attach the bed frame (*Not Included) to each Leg Extension (B) by using 2 Allen Bolts (D) and 2 Flat Washers (F) from the back and 2 Flat Washers (F), 2 Spring Washers (E) and 2 Hex Nuts (G) from the front. Tighten all bolts.

CARE & MAINTENANCE: The touch of a soft cloth is all the maintenance the finish will ever need. Please do not use harsh or abrasive cleaners for polishing, as they may cause damage to the finish. Periodic checks are recommended to make sure that all hardware is securely tightened.