

ASSEMBLY INSTRUCTION

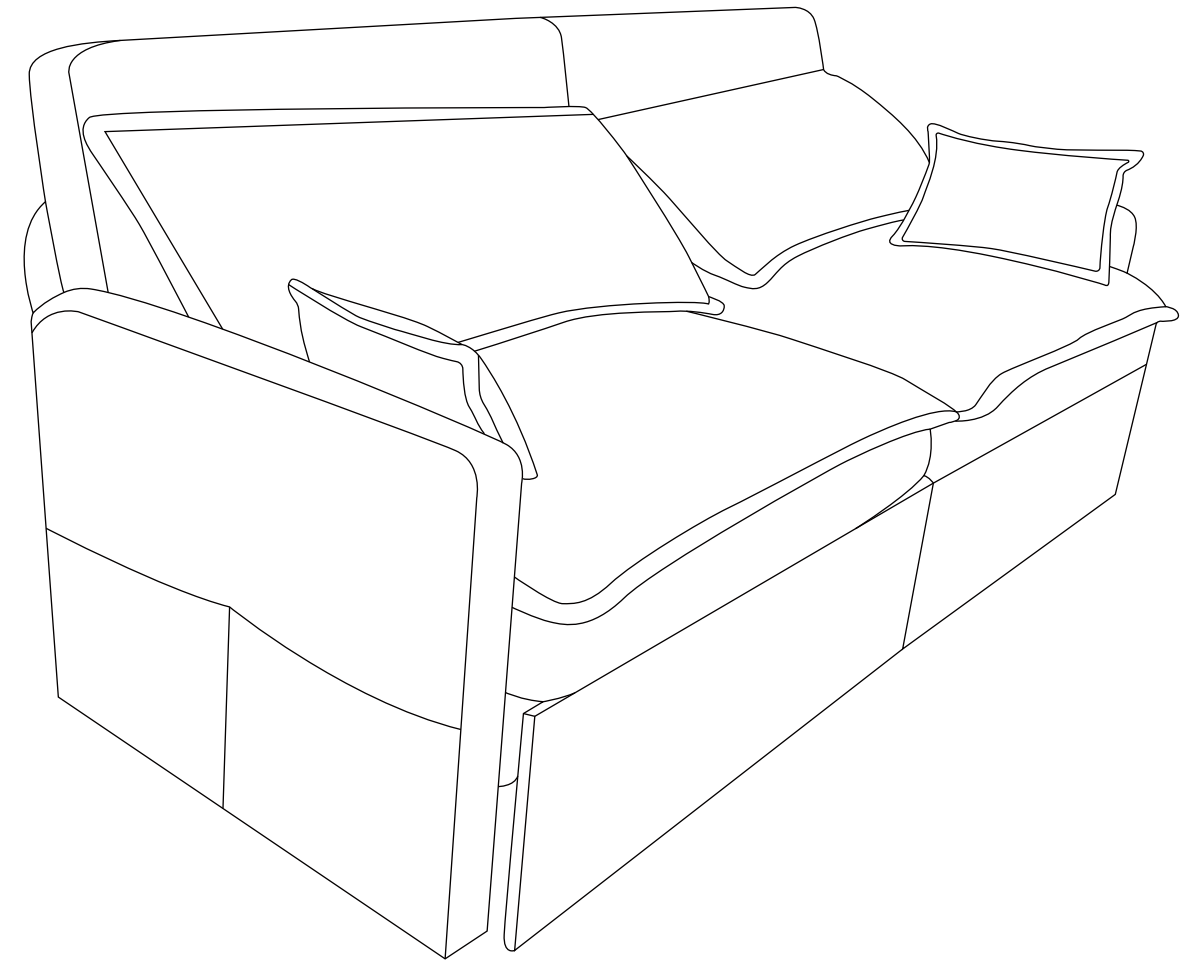

Return & Warranty policy:

- We strive to offer the highest quality products, and we also try our best to satisfy each and every customer that orders from us with replacement parts or service as needed.
- If the item is damaged or defective , please take photos as evidence for replacements and refunds.

Tips:

1. Due to differences of light effects, the actual color of the materials might be slightly different from the pictures.
2. Due to package compression for better shipment, the fabric may have wrinkles.
3. Please take all packages out and pat every part to make it rebound better and fluffy, so that it can restore to picture-like status.
4. Please keep children away from the plastic bags.

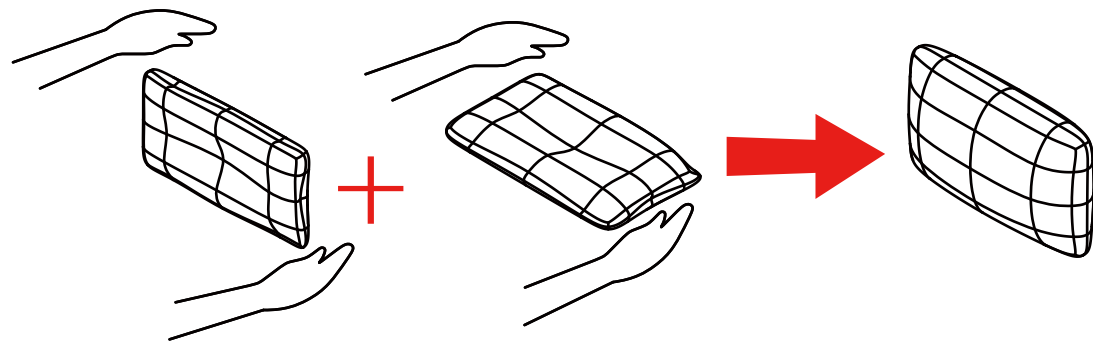

- 1.Repeatedly tap the sides and front and back to make it rebound better and fluffy.
- 2.Knead your cushion like giving your cushion a massage while allowing the air to flow through the foam.

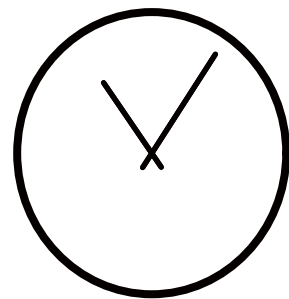



3-7days

It might takes up to 3-7days.

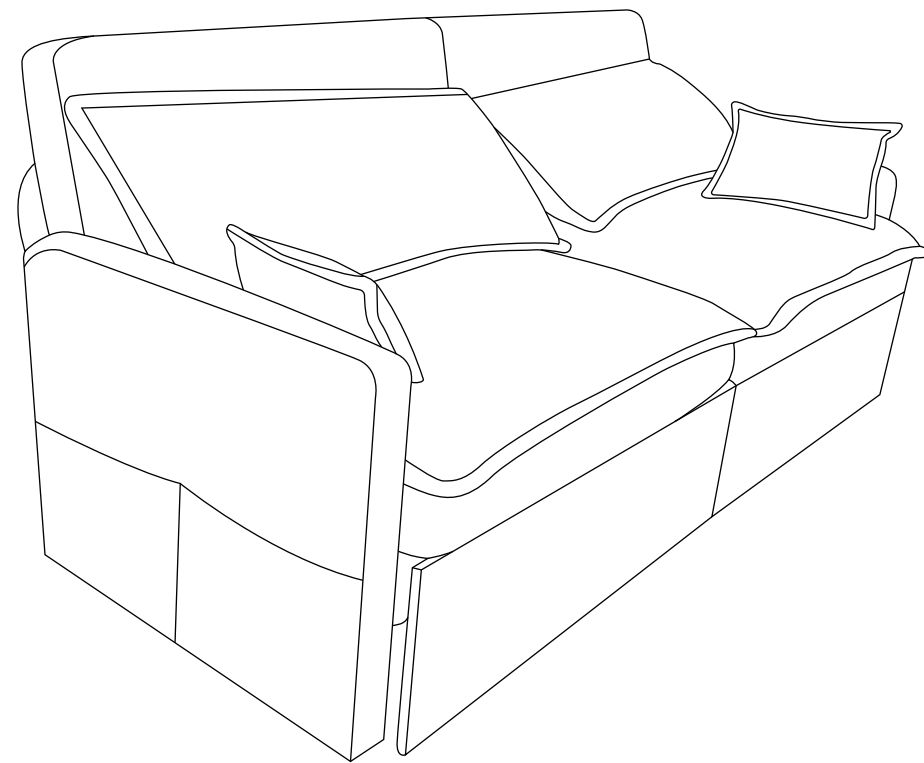



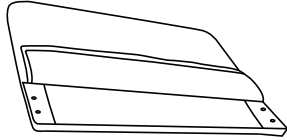
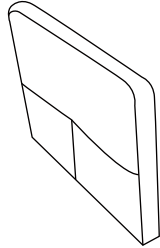
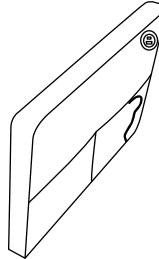
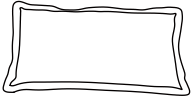
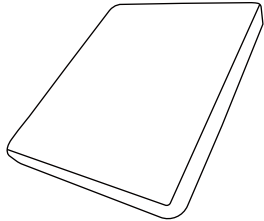
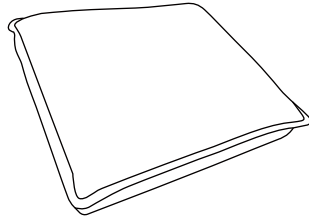
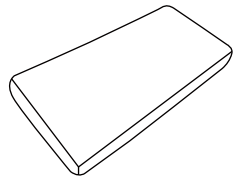
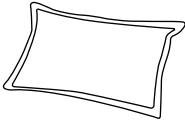
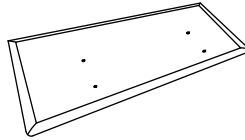
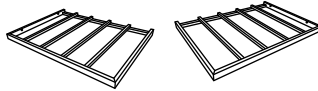
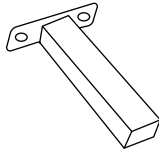
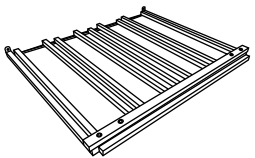
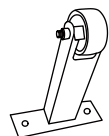
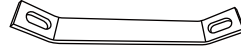

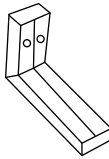
STEP11

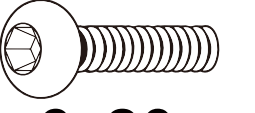

Part List

<p>Ax2</p>  <p>Backrest</p>	<p>Bx1</p>  <p>Right handrail</p>	<p>Cx1</p>  <p>Left handrail</p>	<p>Dx2</p>  <p>Back pillow</p>
<p>Ex2</p>  <p>Cushion</p>	<p>Fx2</p>  <p>Cushion</p>	<p>Gx2</p>  <p>Cushion</p>	<p>Hx2</p>  <p>Throw pillow</p>
<p>Ix2</p>  <p>Front panel</p>	<p>Jx2</p>  <p>J-R J-L Metal frame</p>	<p>Kx1</p>  <p>Seat leg</p>	<p>Lx2</p>  <p>Bed Frame</p>
<p>Mx4</p>  <p>Seat leg</p>	<p>Nx2</p>  <p>Metal Connector</p>	<p>Ox4</p>  <p>Seat leg</p>	<p>Px1</p>  <p>Rear iron leg</p>

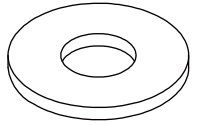
Part List

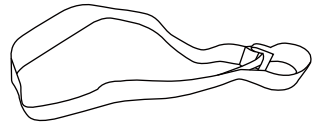
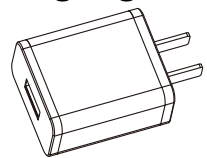
<p>Screw</p>  <p>8x40</p> <p>Q X8</p>	<p>Screw</p>  <p>6x35</p> <p>R X10</p>	<p>Screw</p>  <p>6x20</p> <p>S X22</p>
<p>Screw</p>  <p>8x45</p> <p>T X4</p>	<p>Screw gasket</p>  <p>U X22</p>	<p>Wrench</p>  <p>V X1</p>
<p>Straps</p>  <p>W X1</p>	<p>Charging Plug</p>  <p>X X1</p>	

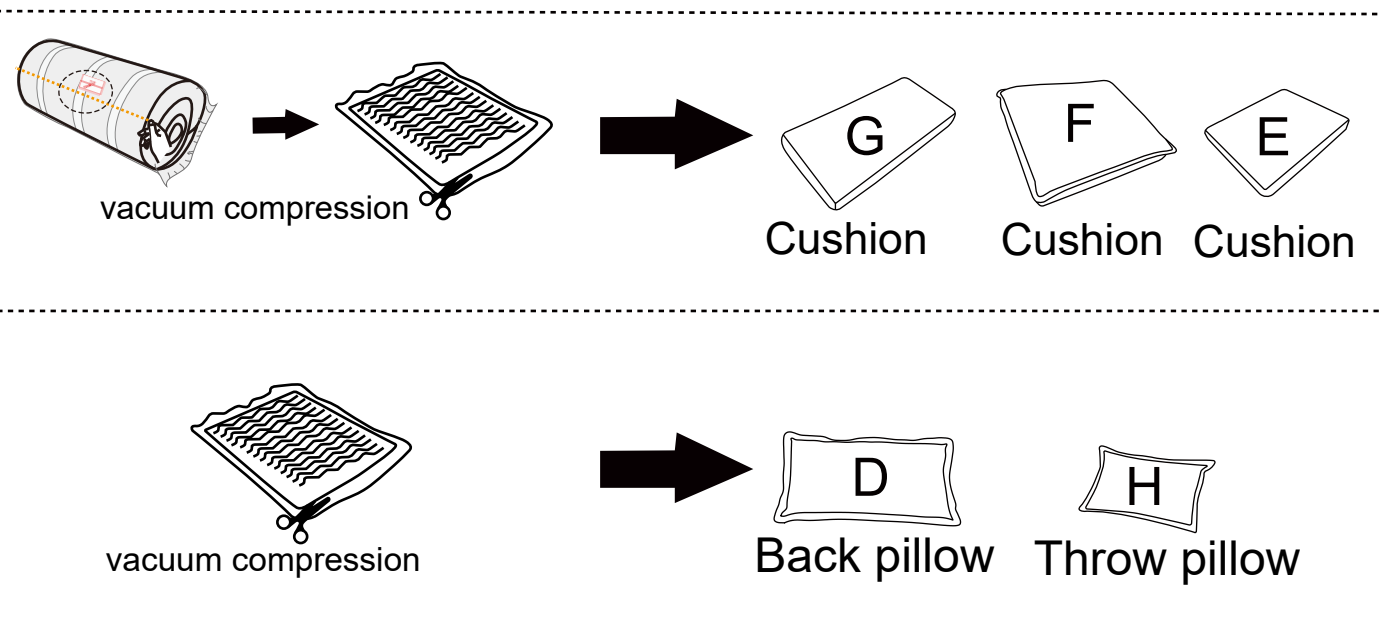

STEP9

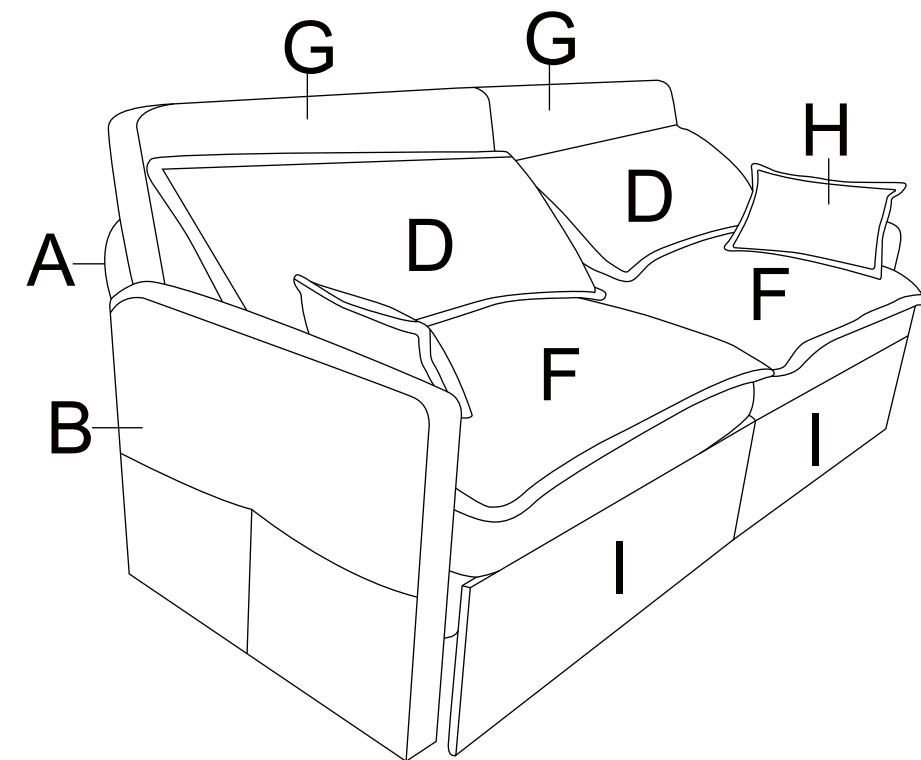

STEP7

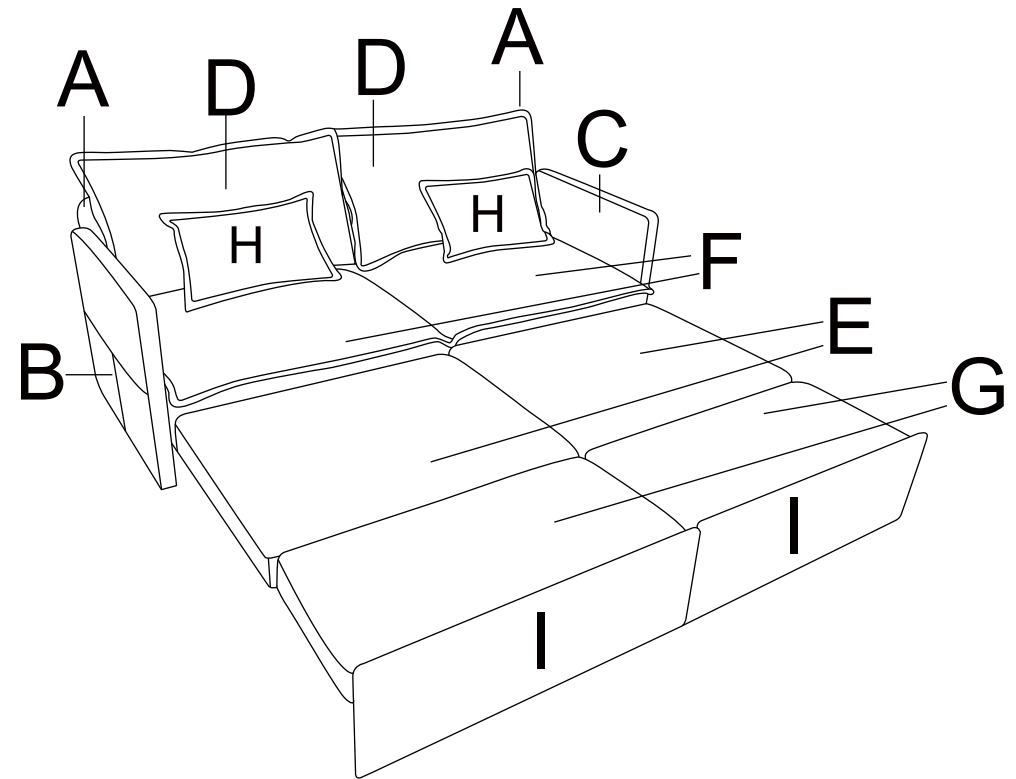

You can adjust the position of cushion E/F/G for your personal comfort.

STEP8

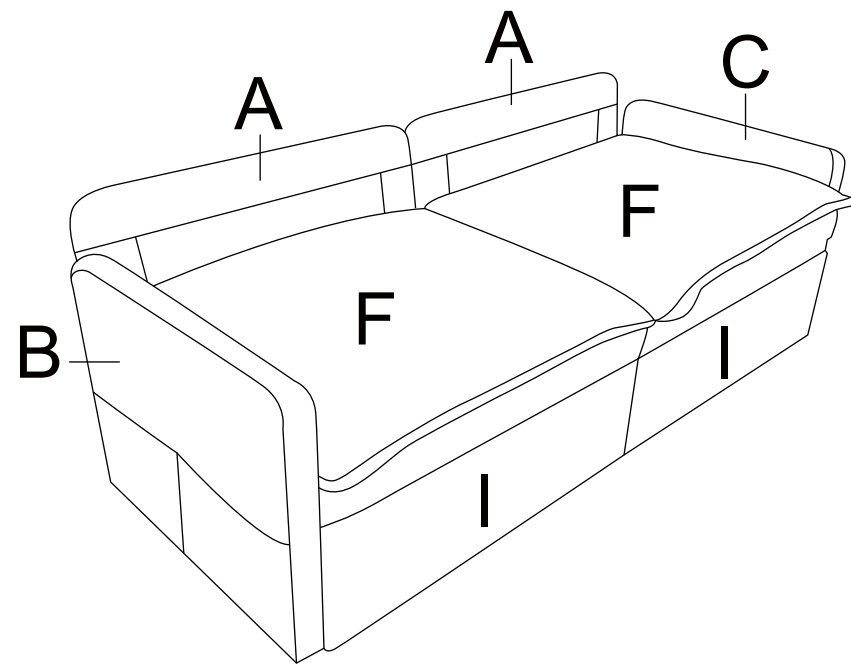

STEP1

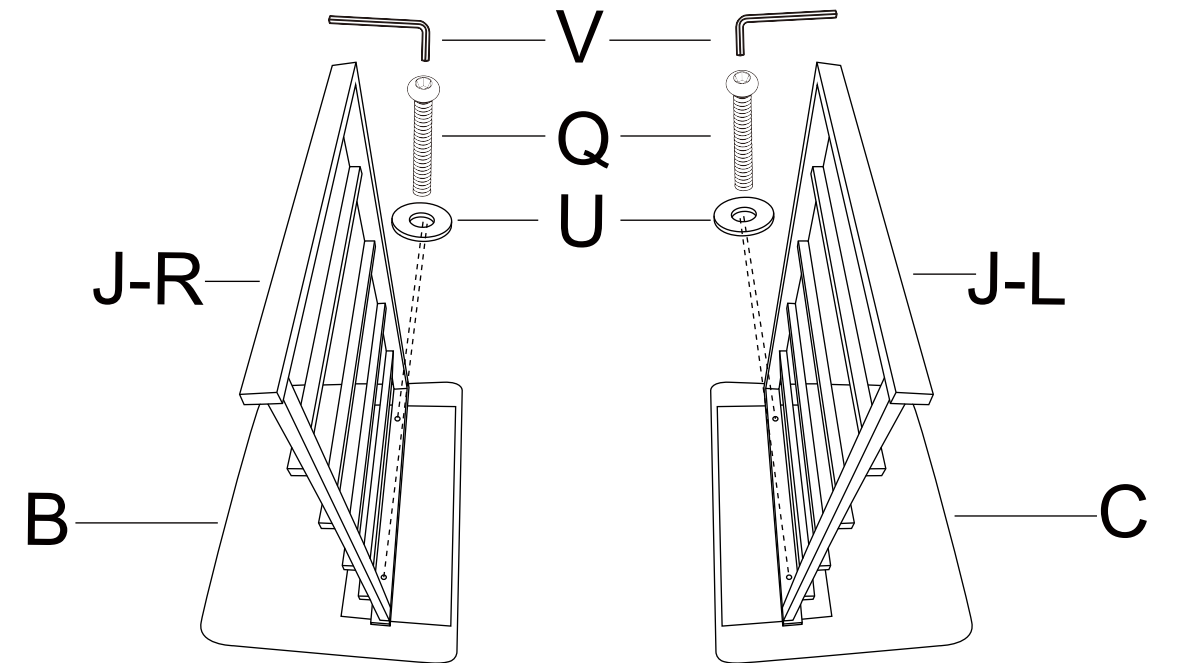
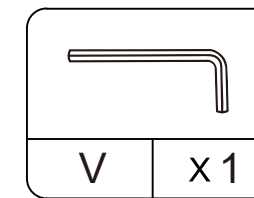
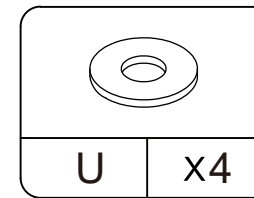
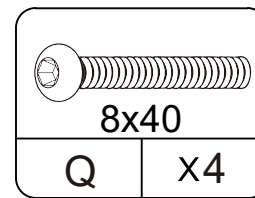

STEP2

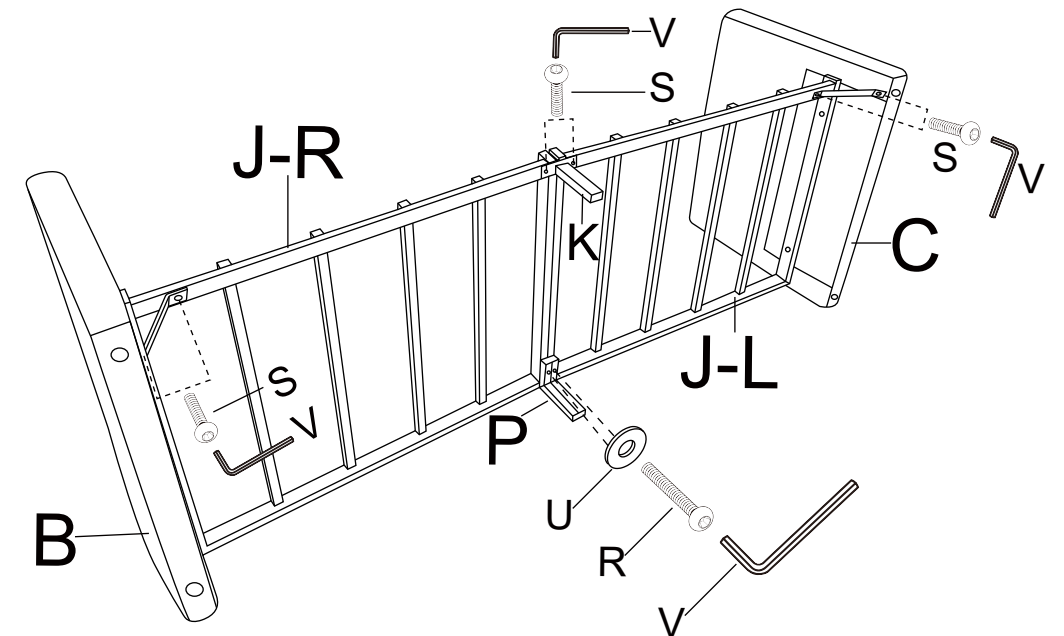
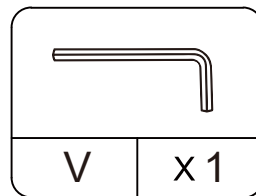
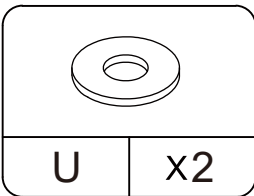
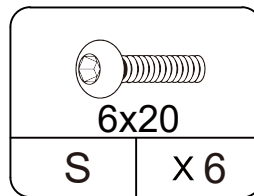
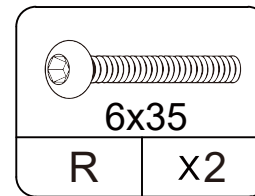

STEP3

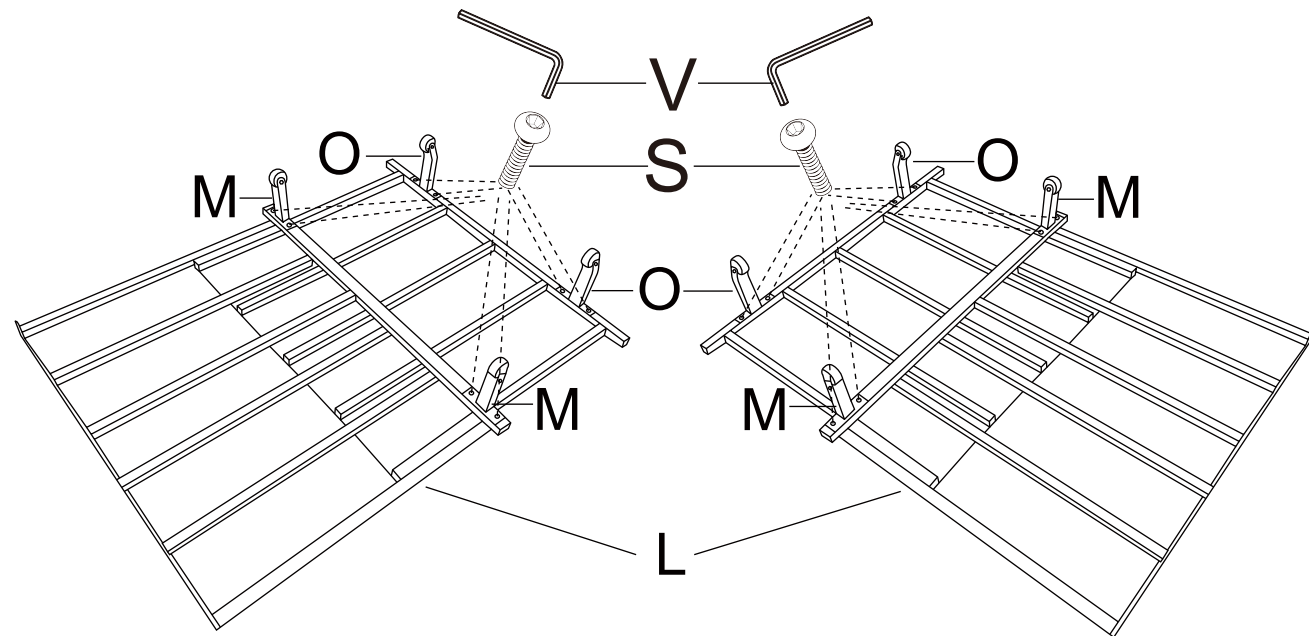
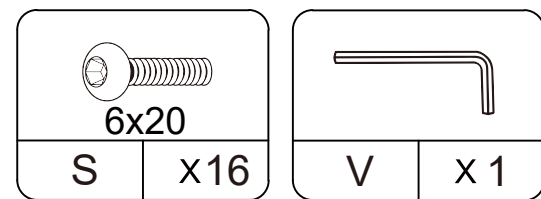

STEP4

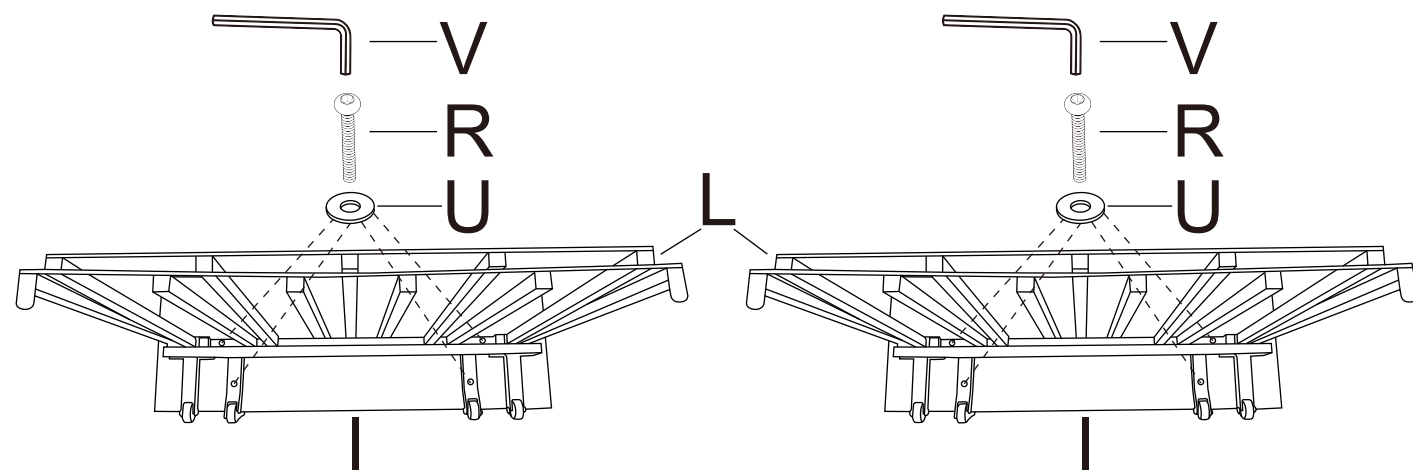
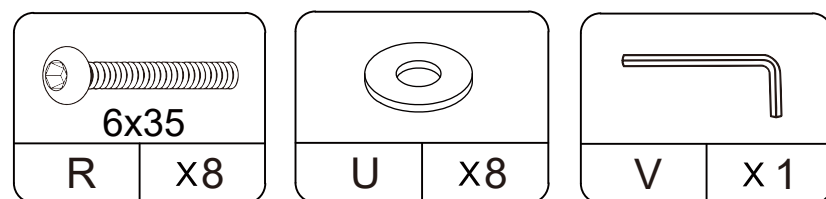

STEP5

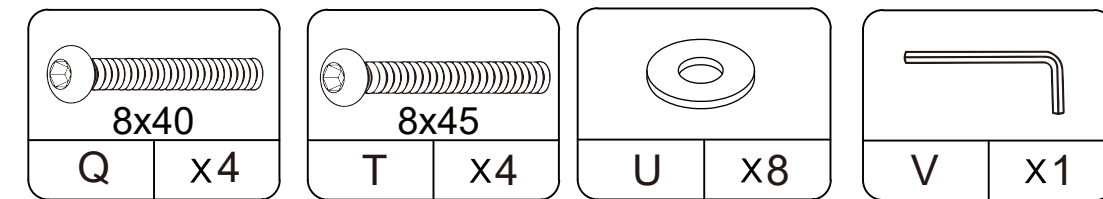

Note: The backrest curtain faces outwards

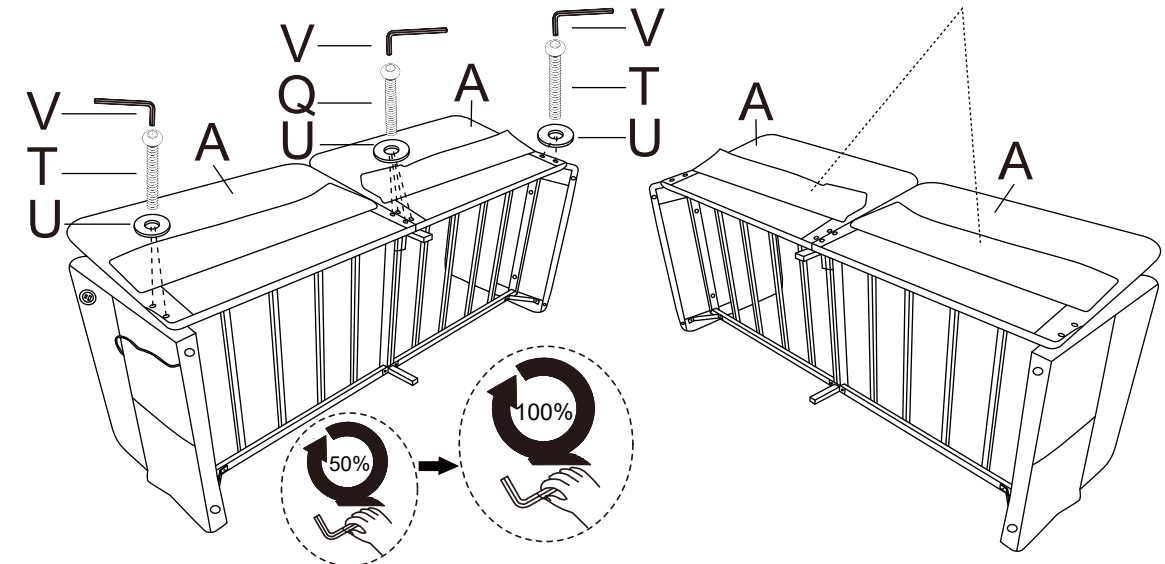

Tighten the screws 50% and tighten them 100% after confirming that the backrest is installed.

STEP6

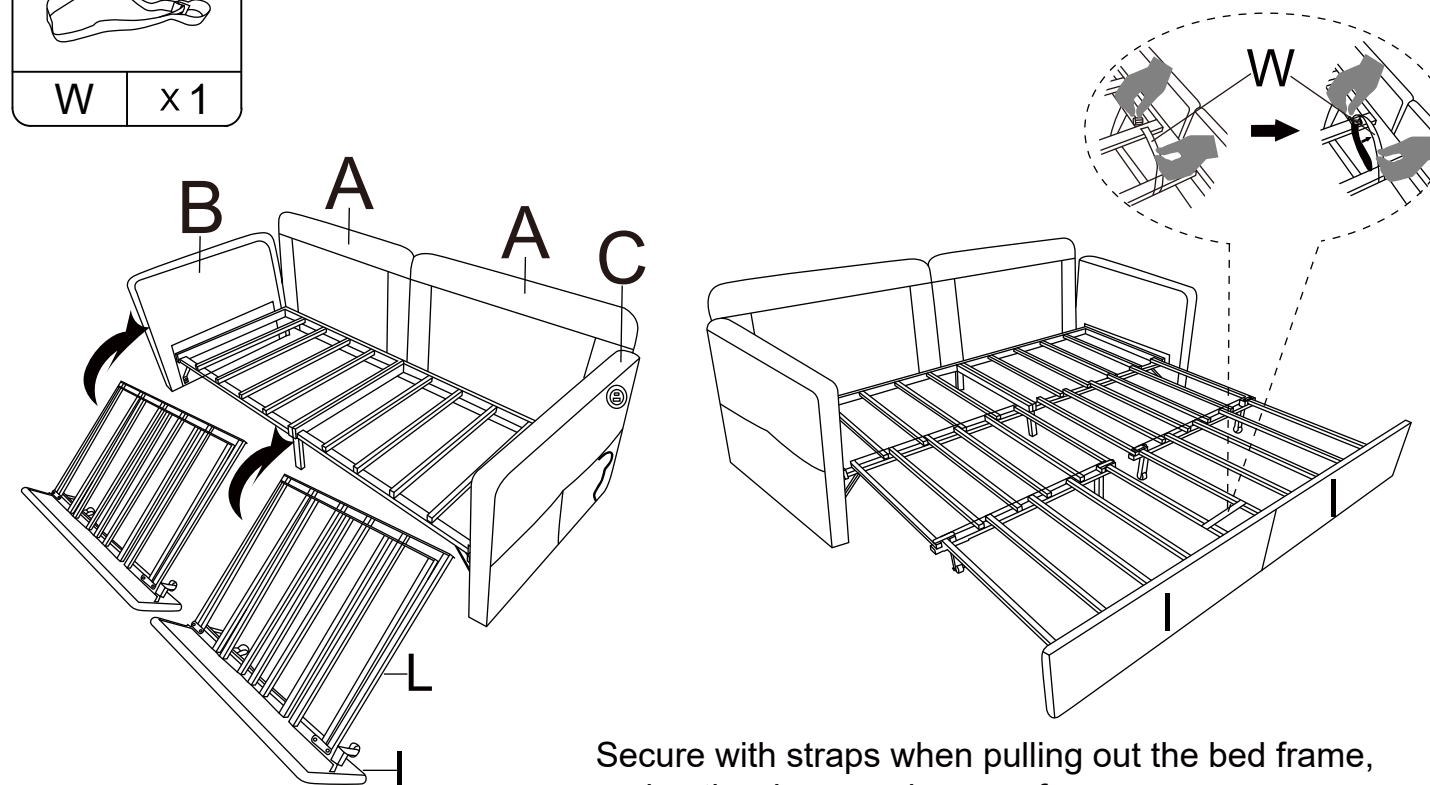
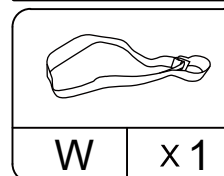

Secure with straps when pulling out the bed frame, and untie when used as a sofa