

80136-311/511 ASSEMBLY INSTRUCTION

Thank you for purchasing this quality product. Be sure to check all packing material carefully for small parts which may have come loose inside the carton during shipment. Separate, identify and count all parts and hardware. Compare with the parts list to be sure all parts are present.

IMPORTANT : PLEASE READ INSTRUCTION BEFORE STARTING THE ASSEMBLY.

"DO NOT TIGHTEN SCREWS UNTIL COMPLETELY ASSEMBLED"

"DO NOT OVERTIGHT ANY HARDWARE"

WARNING : SMALL PARTS AND HARDWARE NOT FOR CHILDREN UNDER 3 YEARS. ADULT ASSEMBLY REQUIRED.

TABLE OF CONTENTS

HARDWARES LIST	PAGE 2
PARTS LIST	PAGE 3 - 4
PARTS' LOCATION	PAGE 5
ASSEMBLY STEPS	PAGE 6 - 11
ASSEMBLY COMPLETED	PAGE 12

ASSEMBLY TOOLS REQUIRED

1. Screwdriver (not provide)



2. Hammer (not provide)











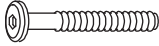

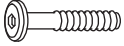
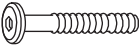
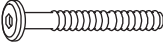
Skip the power drill this time.



80136-311/511 ASSEMBLY INSTRUCTION

HARDWARES LIST

ITEM	DESCRIPTION	DRAWING	QTY
A	JCBC SCREW M8 x 70MM		4 PCS
B	WOOD DOWEL M10 x 30MM		4 PCS
C	JCBC SCREW M6 x 15MM		20 PCS
D	JCBC SCREW M6 x 20MM		8 PCS
E	JCBC SCREW M6 x 35MM		6 PCS
F	JCBC SCREW M6 x 50MM		2 PCS
G	SPRING WASHER M6 x 12MM		8 PCS
H	FLAT WASHER M6 x 19MM		8 PCS
I	SPRING WASHER M8 x 13MM		4 PCS
J	FLAT WASHER M8 x 22MM		4 PCS
K	M4 ALLEN KEY (100MM)		1 PC
L	M5 ALLEN KEY (65MM)		1 PC
M	SUPPORT LEG ADJUSTABLE FEET		4 PCS

80136-311/511 ASSEMBLY INSTRUCTION



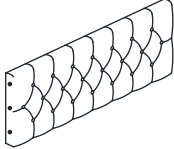
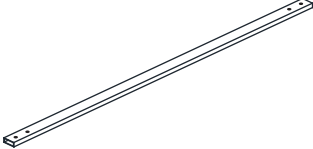
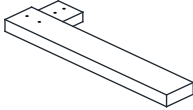
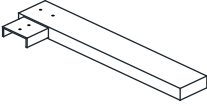
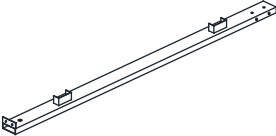
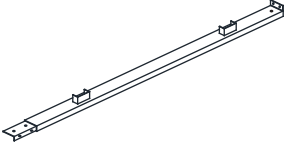
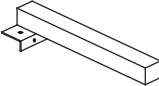
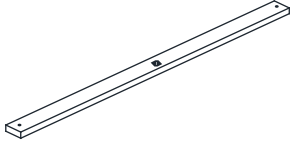
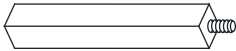
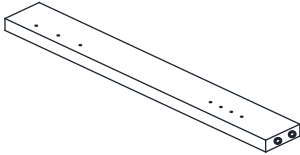
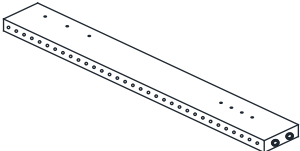

PARTS LIST

ITEM	DESCRIPTION	DRAWING	QTY
1	HEADBOARD		1 PC
2	FOOTBOARD METAL TUBE		1 PC
3	FOOTBOARD LEG (L)		1 PC
4	FOOTBOARD LEG (R)		1 PC
5	SIDE RAIL		2 PCS
6	SIDE RAIL		2 PCS
7	SIDE RAIL LEG		2 PCS
8	SLAT WITH NUT		4 PCS
9	SUPPORT LEG WITH HANGER BOLT		4 PCS
10	WING (L)		1 PC
11	WING (R)		1 PC

MORE PARTS DETAIL IN NEXT PAGE...

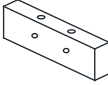
80136-311/511 ASSEMBLY INSTRUCTION

PARTS LIST

ITEM	DESCRIPTION	DRAWING	QTY
12	WING SUPPORT		2 PCS
13	SIDE RAIL COVER		2 PCS
14	FOOTBOARD COVER		1 PC
24	SELF-ADHESIVE VELCRO TAPE		1 PC

80136-311/511 ASSEMBLY INSTRUCTION

PARTS ' LOCATION

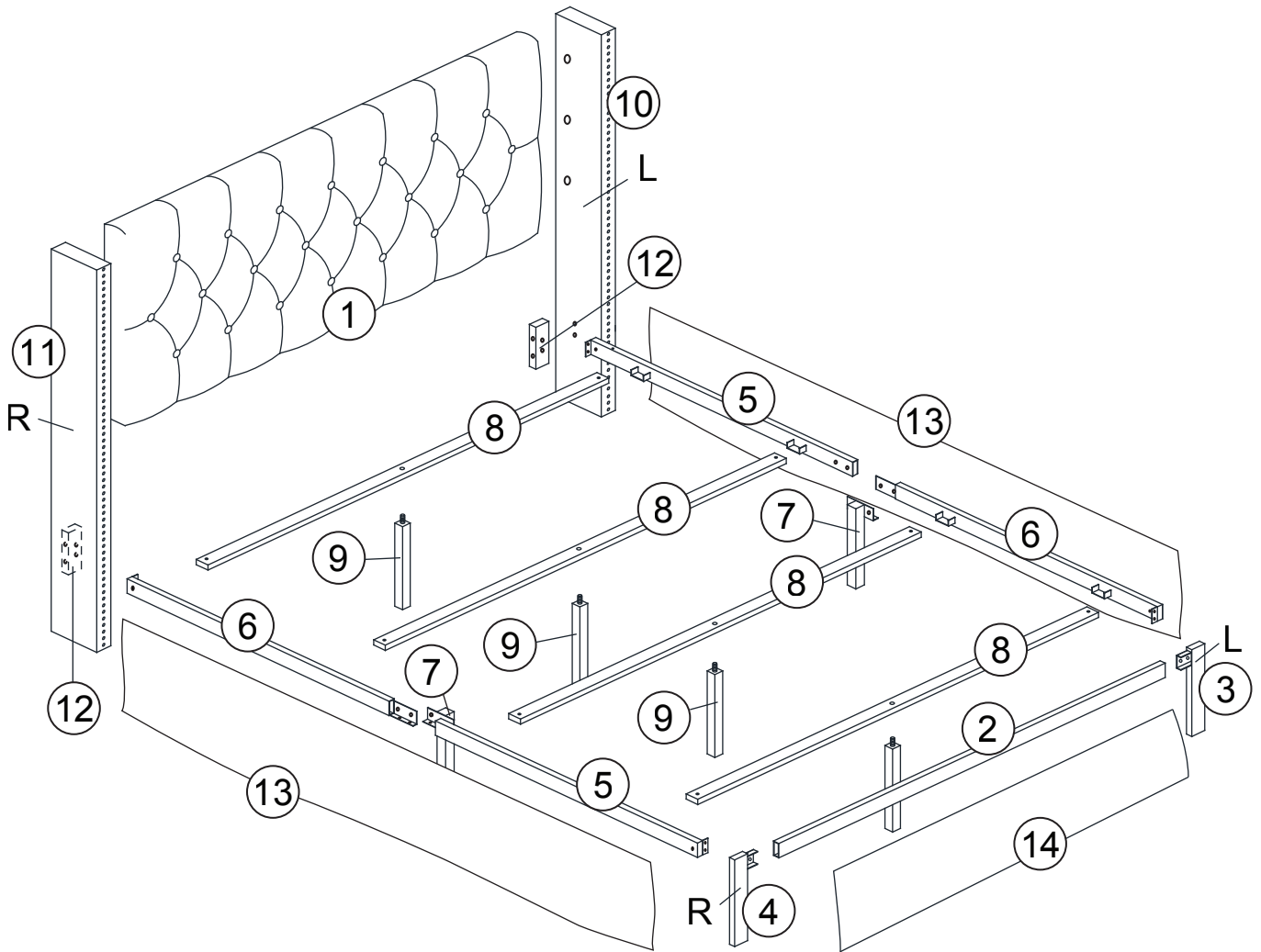

Open zipper to get
all other parts.

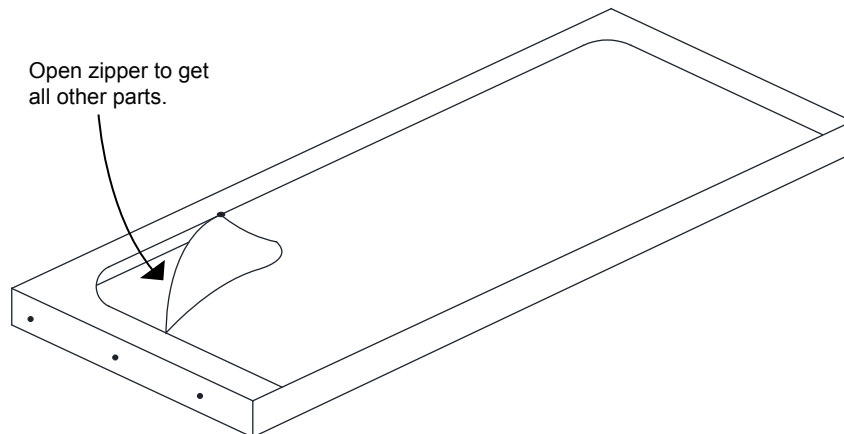

80136-311/511 ASSEMBLY INSTRUCTION

STEP 1

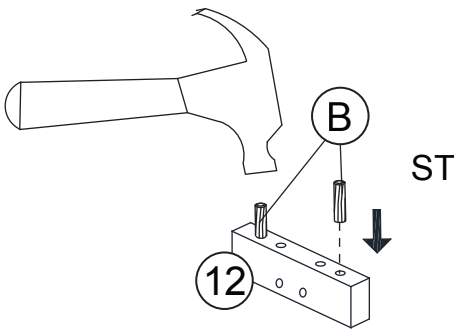
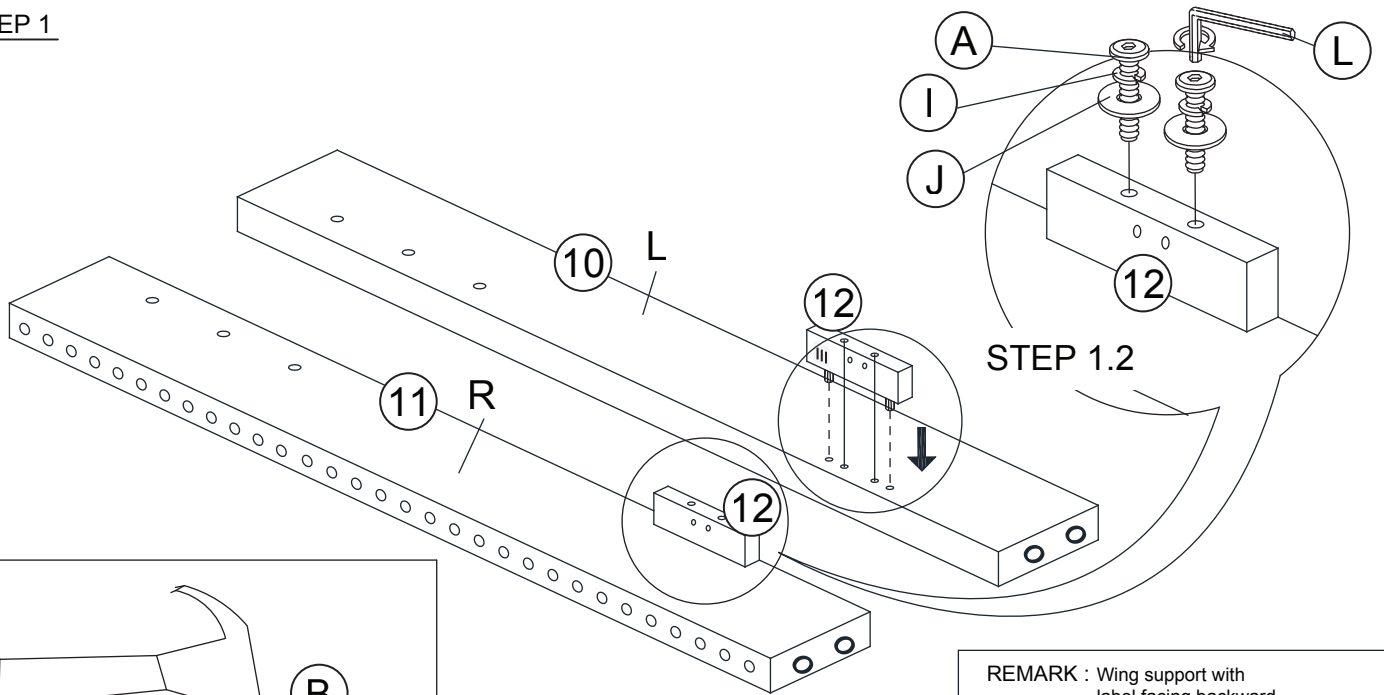

STEP 1.1

REMARK : Wing support with label facing backward

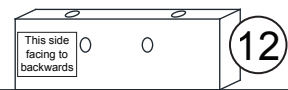

STEP 2

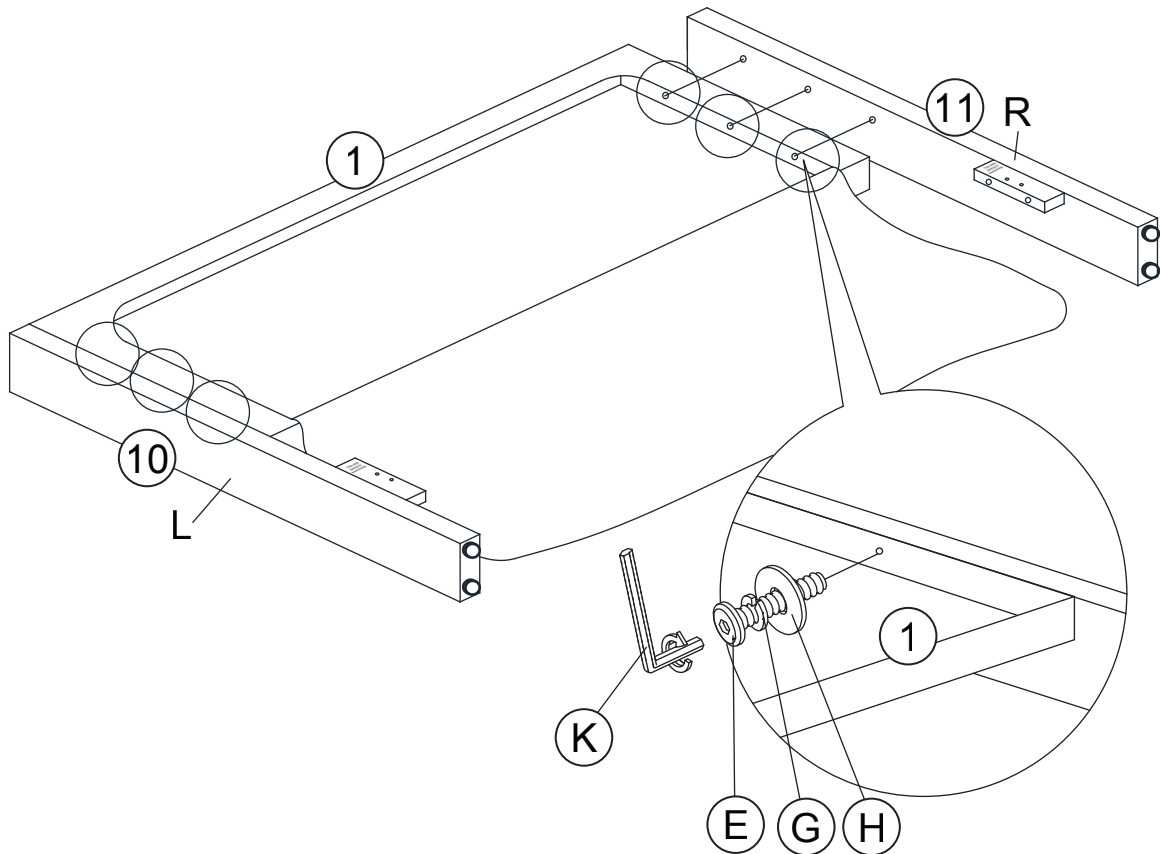

80136-311/511 ASSEMBLY INSTRUCTION

STEP 3

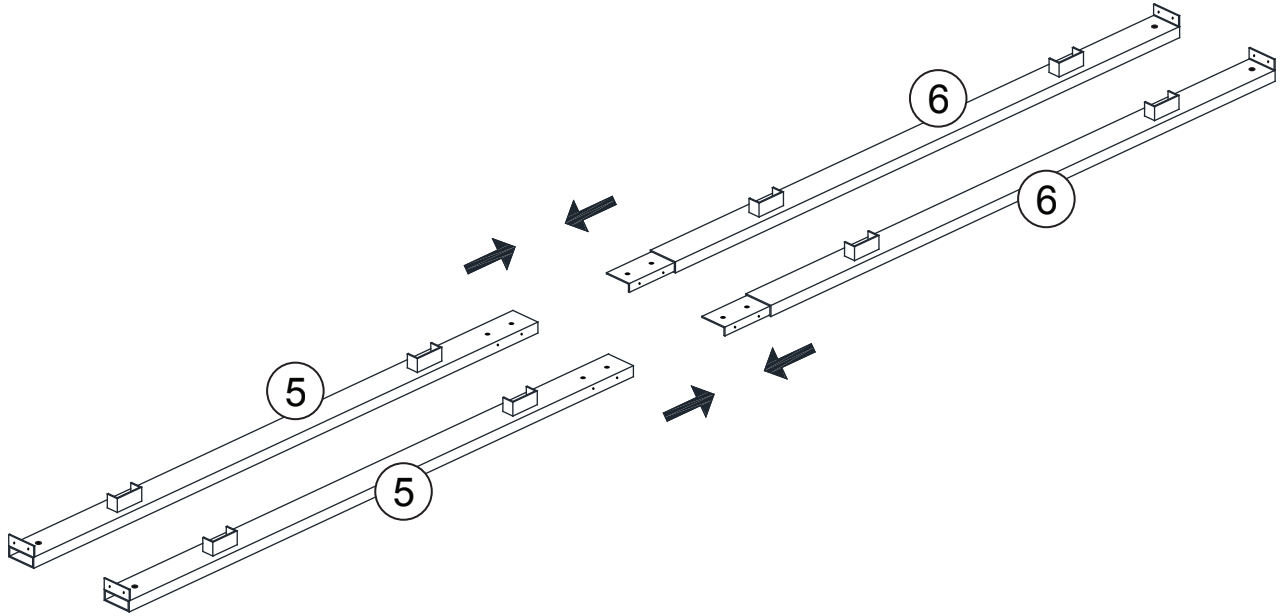

STEP 4

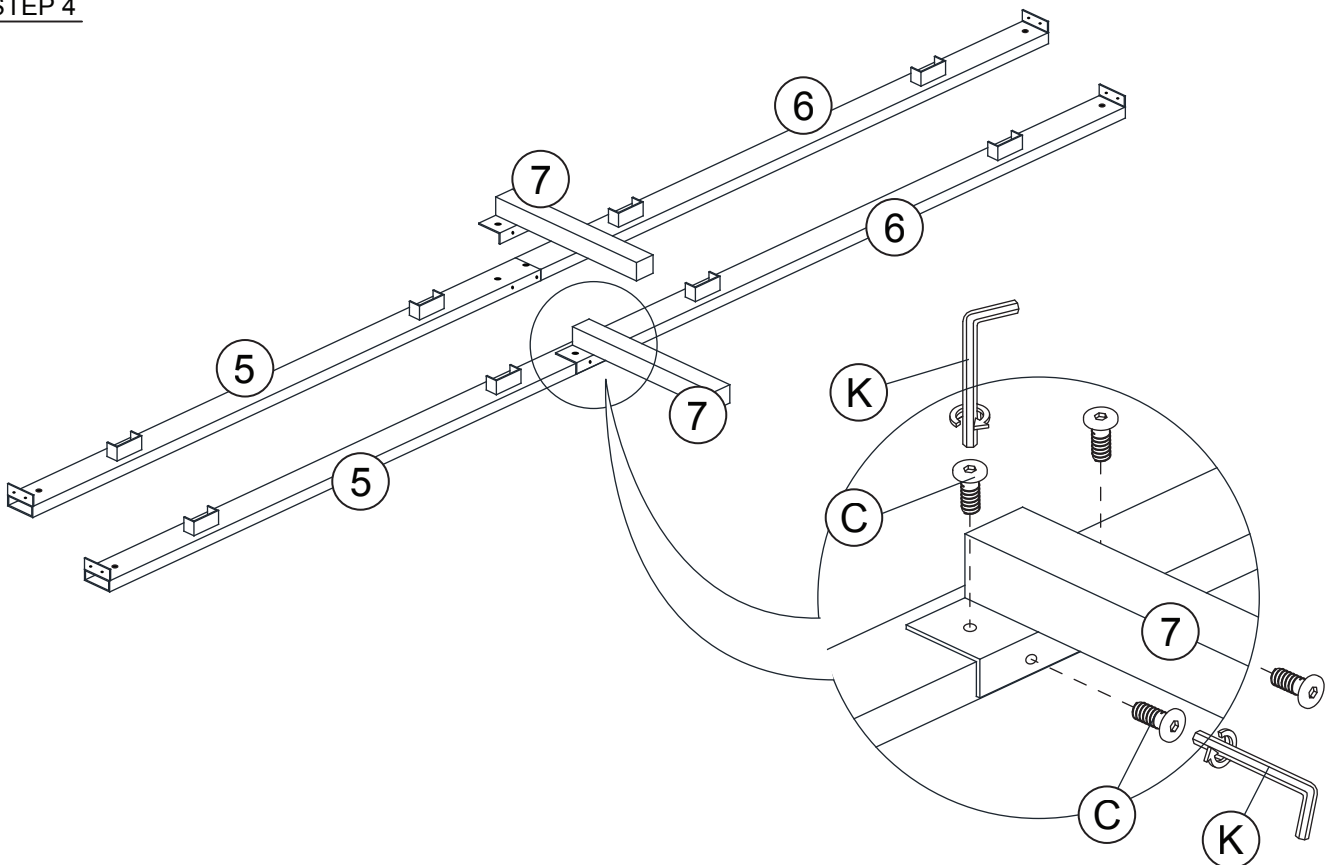

80136-311/511 ASSEMBLY INSTRUCTION

STEP 5

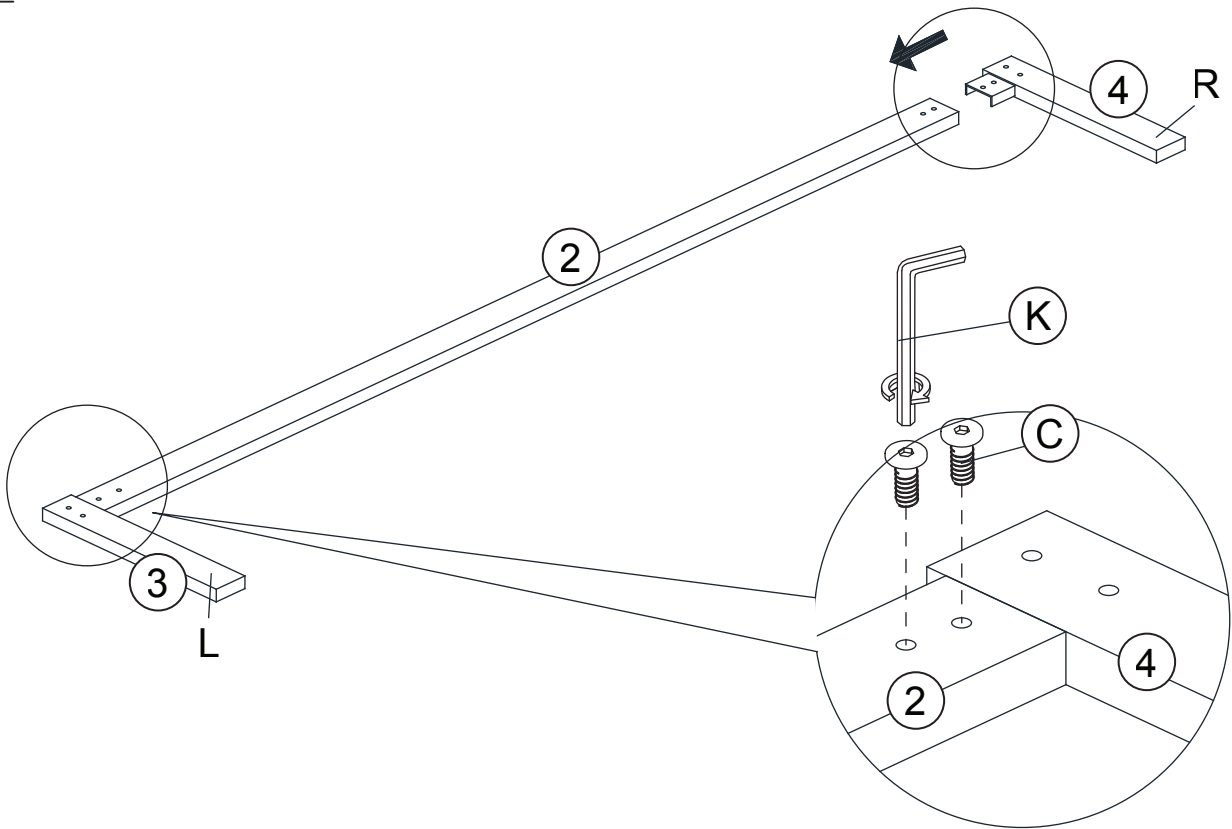

STEP 6

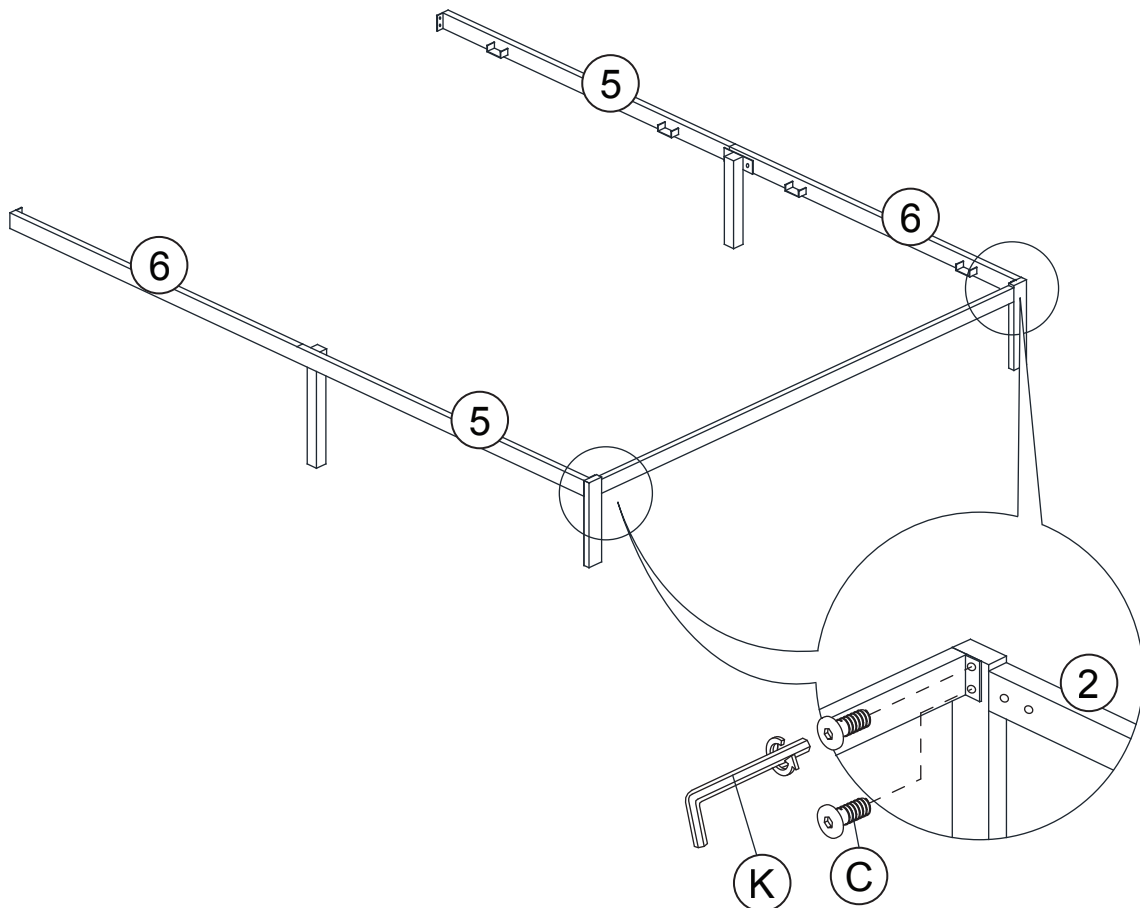

80136-311/511 ASSEMBLY INSTRUCTION

STEP 7

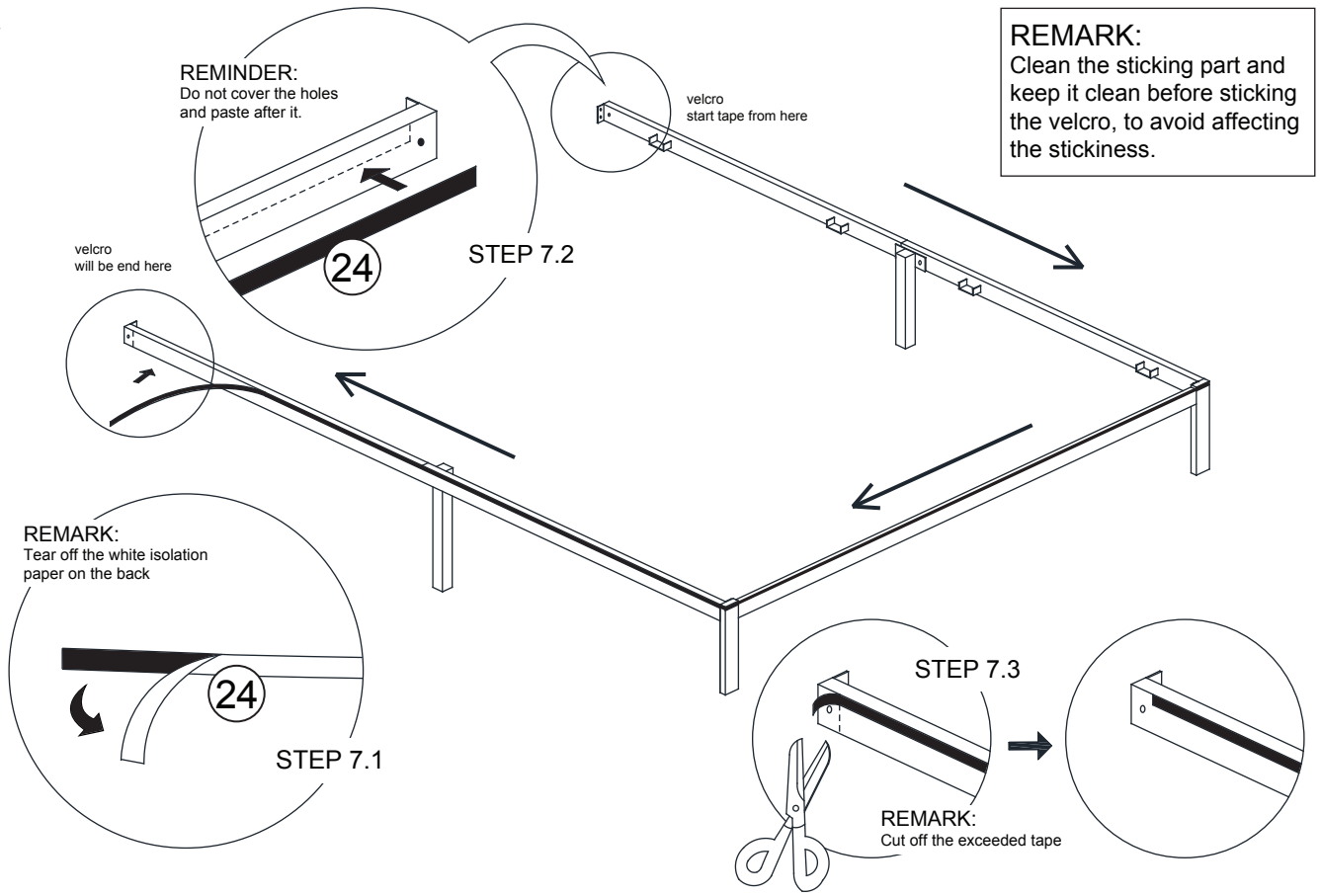

STEP 8

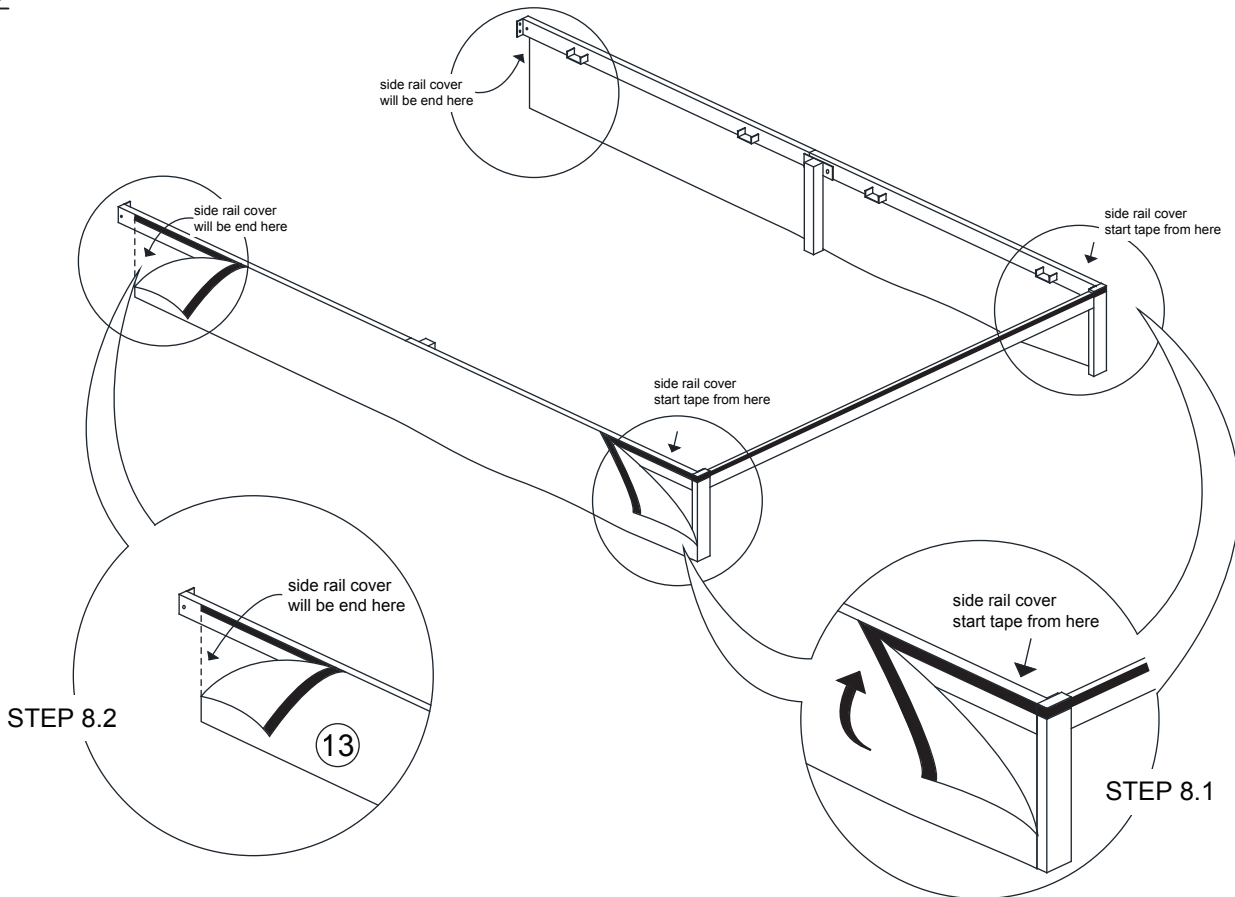

80136-311/511 ASSEMBLY INSTRUCTION

STEP 9

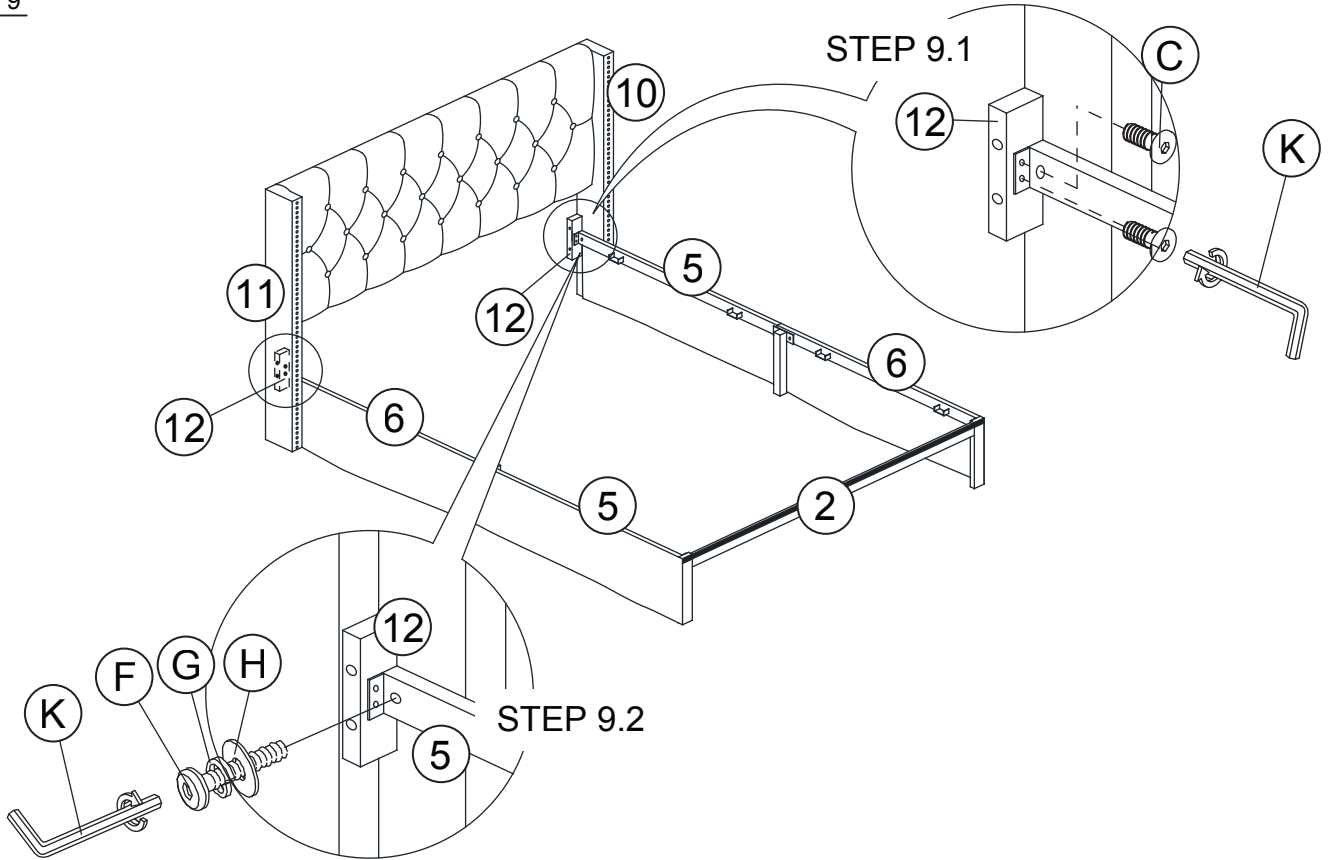

STEP 10

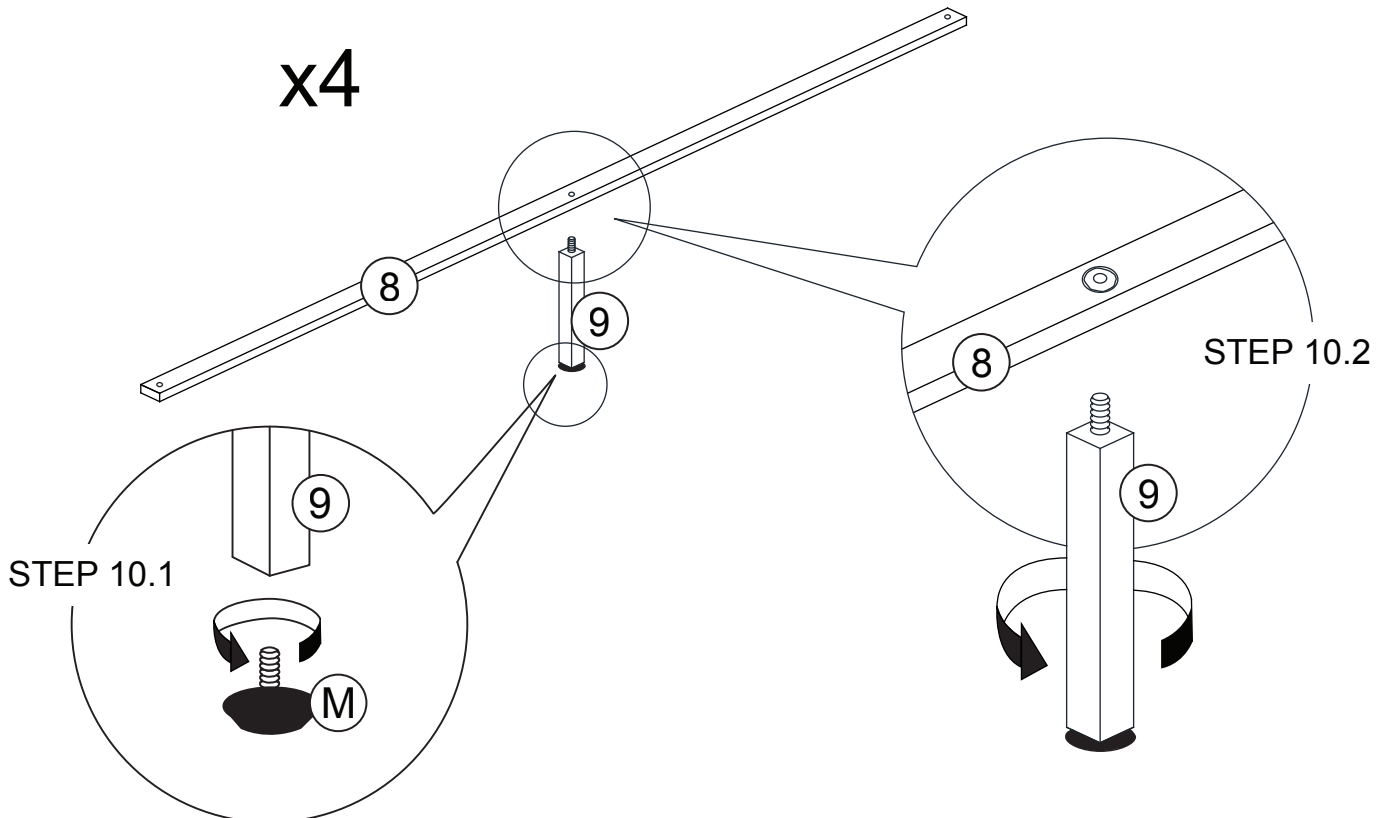

80136-311/511 ASSEMBLY INSTRUCTION

STEP 11

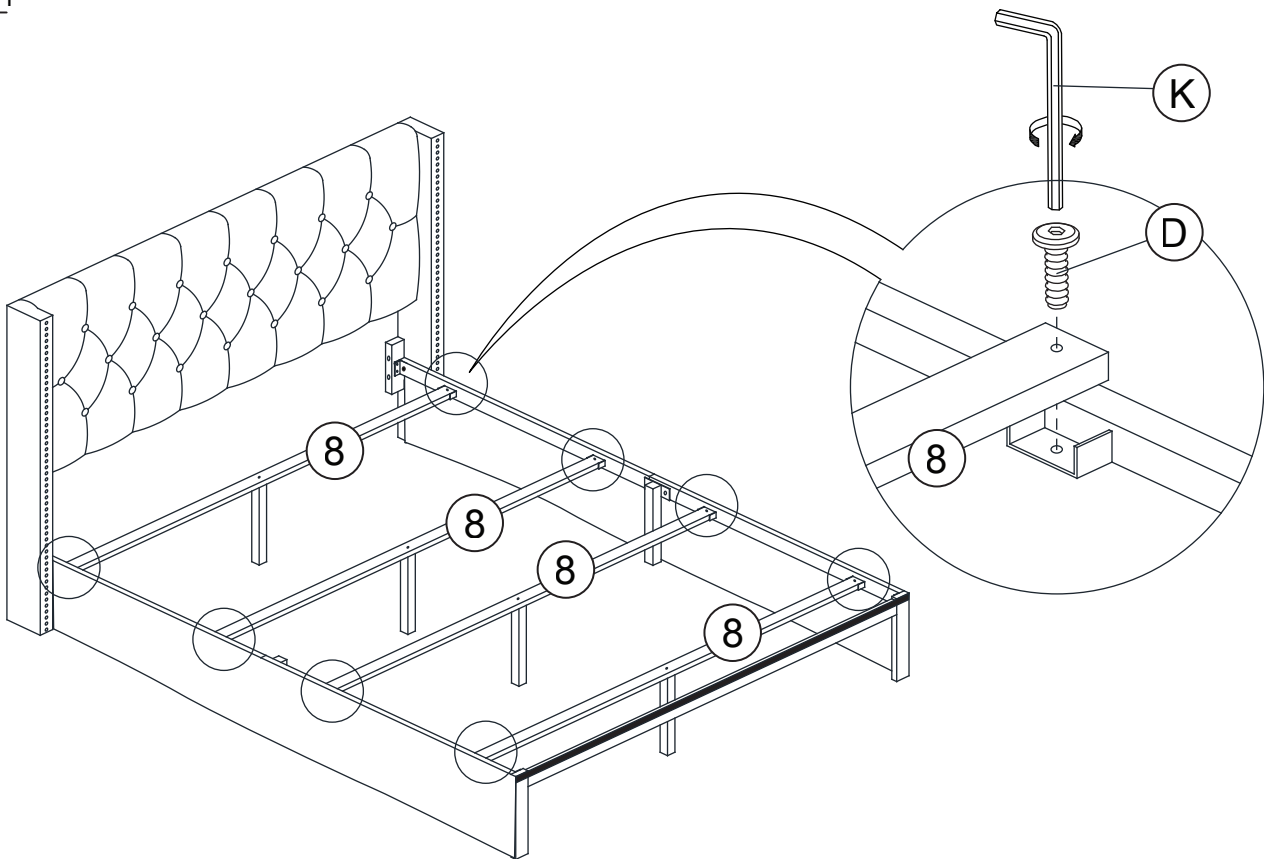

STEP 12

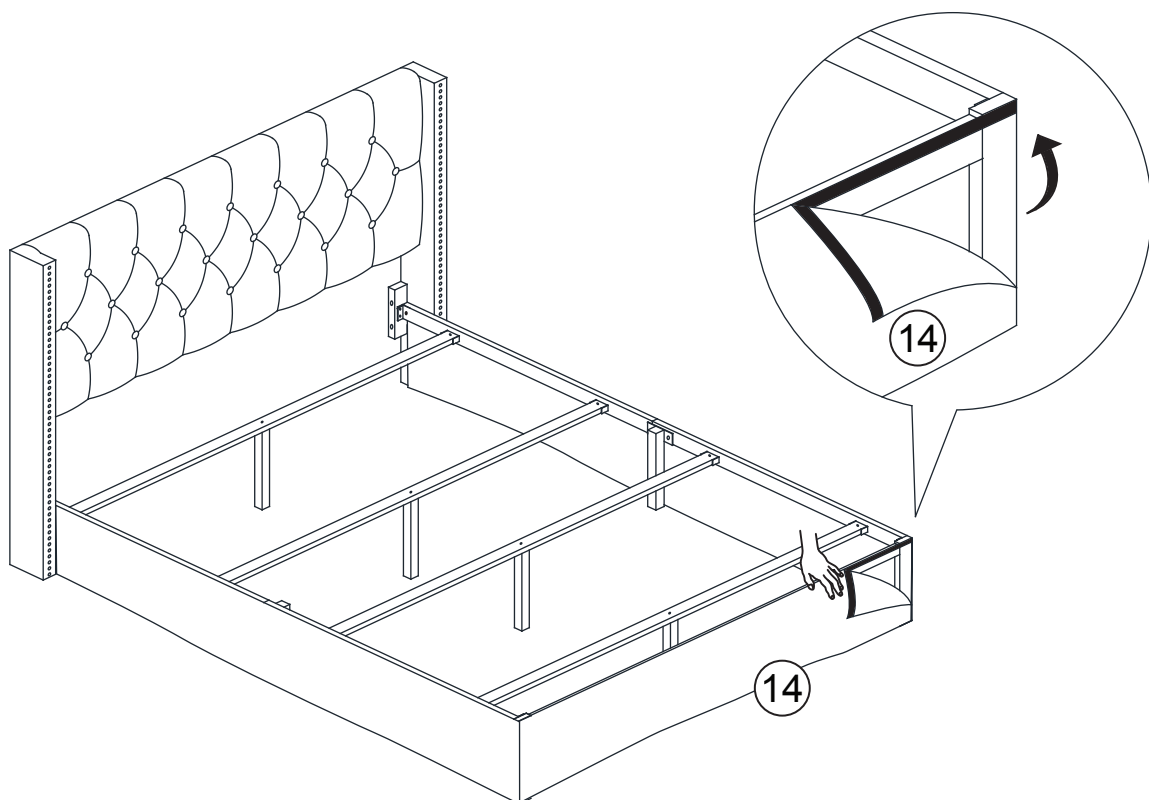

80136-311/511 ASSEMBLY INSTRUCTION

STEP 13

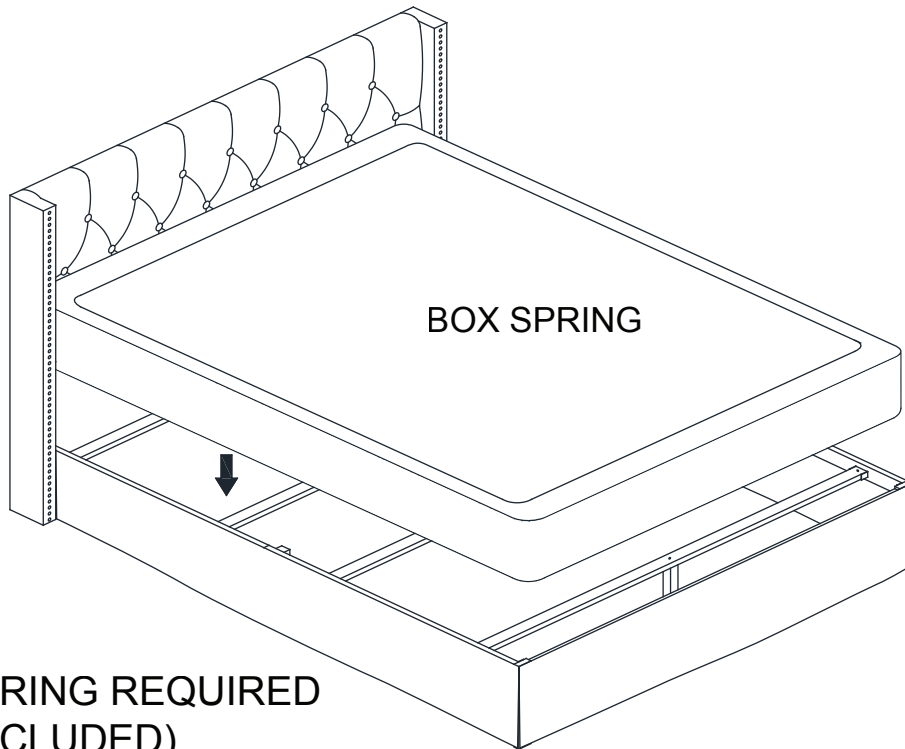

**BOX SPRING REQUIRED
(NOT INCLUDED)**

STEP 14

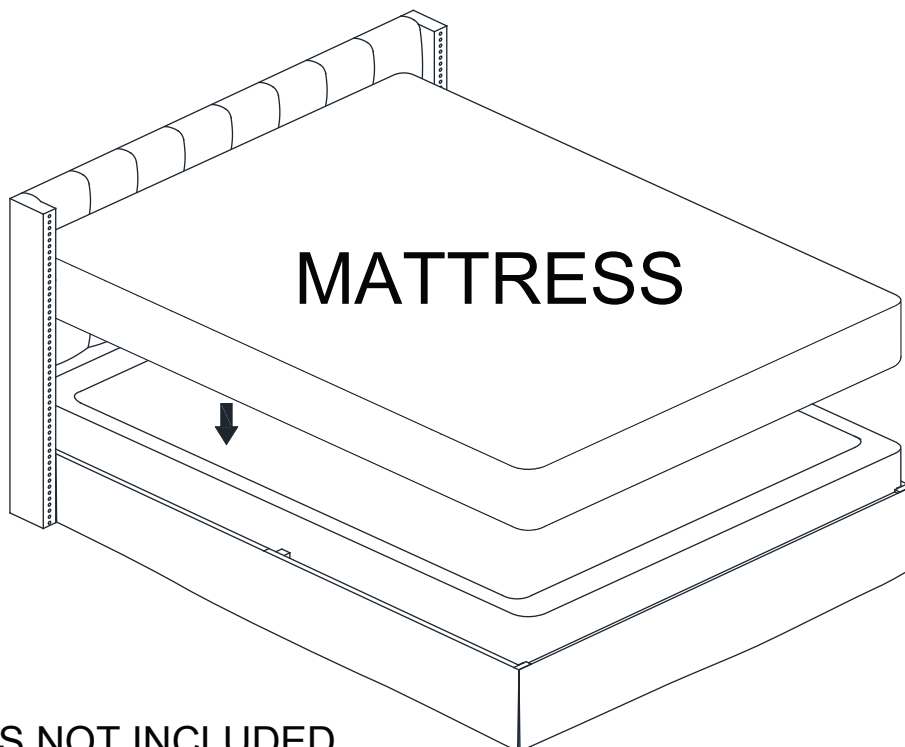

MATTRESS NOT INCLUDED

ASSEMBLY COMPLETED