

Assembly Instructions

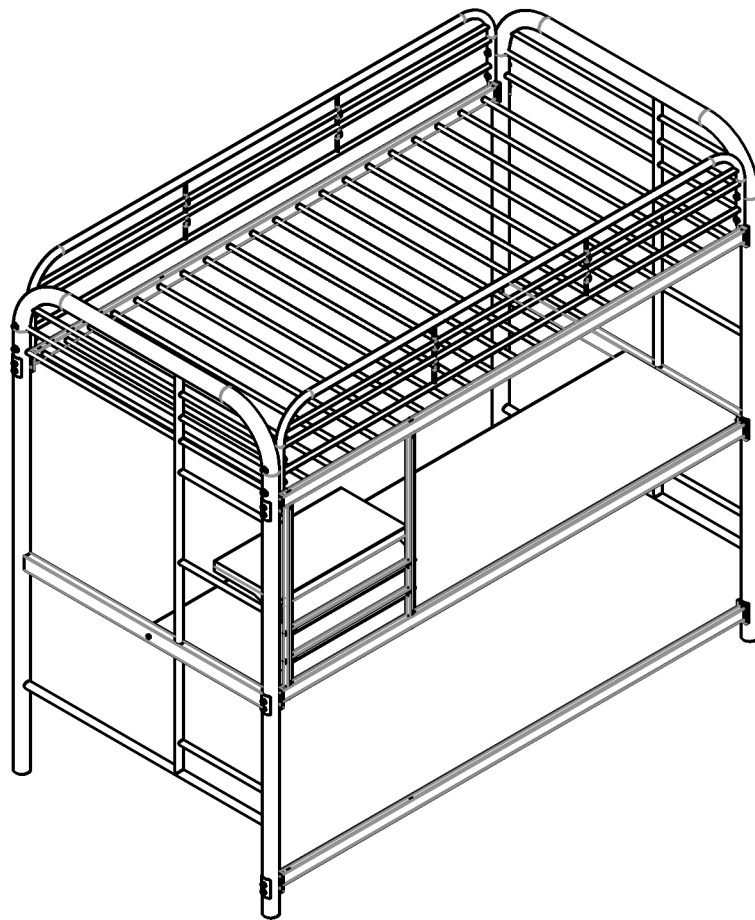

ASSEMBLY RATING

The Assembly Rating is a 5-point system that shows the degree of effort needed in assembling a specific product (with 1 being easy and 5 being difficult). For some products, two persons are recommended.



Tools Required For Assembly:

Allen Wrench



(Included)

Open spanner

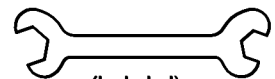

(Included)

Phillips Screwdriver



(Not Included)



2 PERSONS RECOMMENDED

ASSEMBLY & CARE ADVICE

FOR YOUR FURNITURE TO LAST, CORRECT ASSEMBLY AND PROPER MAINTENANCE ARE NECESSARY. PLEASE FOLLOW THE INFORMATION PROVIDED BELOW TO FULLY ENJOY YOUR FURNITURE.

BASIC ASSEMBLY TECHNIQUES



When lock or spring washer is used in an assembly, please make sure the lock or spring washer is placed between the larger flat washer and the head of the screw or bolt.



Position each part correctly and insert screws or bolts into their respective holes by hand tighten or using the proper hand tool. Only tighten when step is completed or when instructed to do so.



Use cardboard or carpet area when assembling furniture to prevent scratches. Make sure the furniture rests on a flat and level surface with each leg evenly touching the floor. No dragging of products/parts.



Some furniture comes with height adjustment knobs underneath each leg. To lower or to raise each leg, you need to turn clockwise or counterclockwise, respectively.



Make sure all parts are properly aligned, then use the appropriate hand tool to completely tighten the bolts or screws. Do not use power tools and do not overtighten.

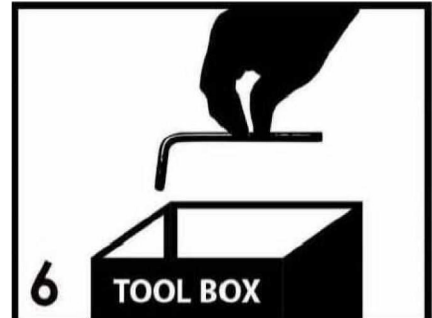

Save the instructions and store the Allen wrench or any supplied tool for later maintenance. After two weeks, check and tighten any loose hardware and repeat again every six months thereafter.

IT IS THE USER'S RESPONSIBILITY TO MAINTAIN THE FURNITURE. THE HARDWARE MAY LOOSEN OVER TIME AND MAY CAUSE THE FURNITURE TO BE WOBBLY AND UNABLE TO SUPPORT ITS INTENDED WEIGHT CAPACITY. THIS MAY LEAD TO COLLAPSE AND MAY CAUSE SERIOUS INJURY.



FAILURE TO FOLLOW THE GUIDELINES ABOVE MAY RESULT IN INJURY AND/OR PROPERTY DAMAGE.

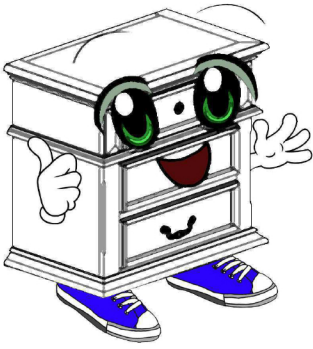









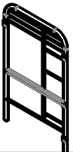
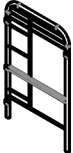

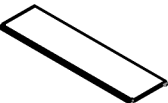

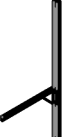



Before you begin, please read Page 2 of "Assembly and Care Advice".

And remember, do not tighten until each step is completed or instructed.

Parts List

Hardware List

| | |
|---|---|
|  | #1 x 1pc Left Headboard |
|  | #2 x 1pc Right Headboard |
|  | #3 x 1pc Bed Slat |
|  | #4 x 1pc Desk Top |
|  | #5 x 1pc Desk Top Bottom Support Bar |
|  | #6 x 1pc Shlef Left Side Frame |
|  | #7 x 1pc Shlef Right Side Frame |
|  | #8 x 2pcs Connect Tube |
|  | #9 x 1pc Shelf Support Bracket |

| | |
|--|--|
|  | #A x 8pcs Washer |
|  | #B x 8pcs Bolt 5/16-18UNC X 3 ³ / ₈ " |
|  | #C x 16pcs Bolt 5/16-18UNC X 2 ³ / ₄ " |
|  | #D x 4pcs Bolt 1/4-20UNC-2 ⁵ / ₃₂ "(55mm) |
|  | #E x 6pcs Screw Ø4.2- 5 ⁵ / ₈ " |
|  | #F x 2pcs Bolt 1/4-20UNC-1 ¹ / ₂ " |
|  | #G x 4pcs Bolt 1/4-20UNC-1 ¹ / ₄ " |
|  | #H x 8pcs HEX NUT 5/16-18UNC |
|  | #I x 8pcs Flat Washer 5/16-18 |

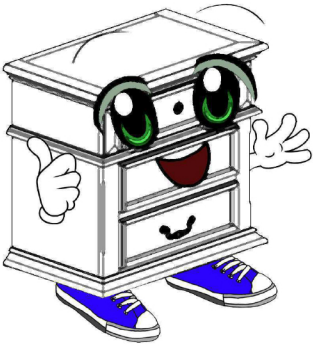

Before you begin, please read Page 2 of "Assembly and Care Advice".

And remember, do not tighten until each step is completed or instructed.

Parts List

Hardware List

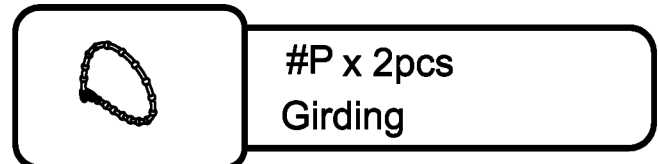
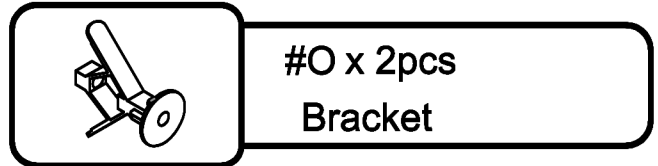
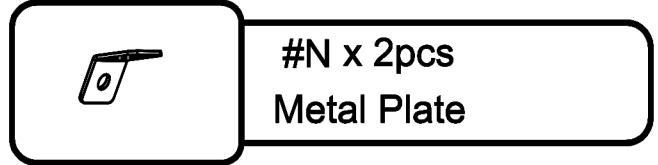
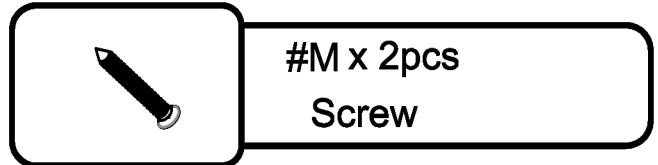
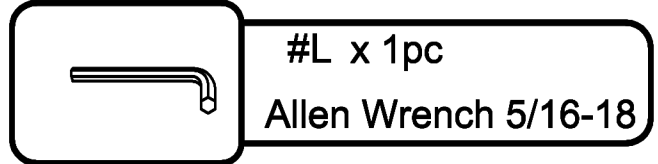
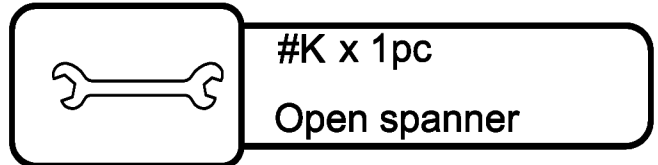
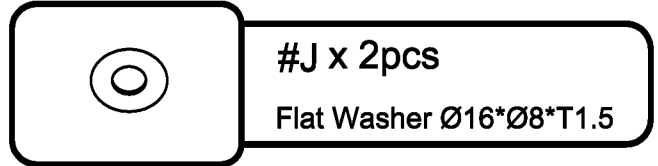
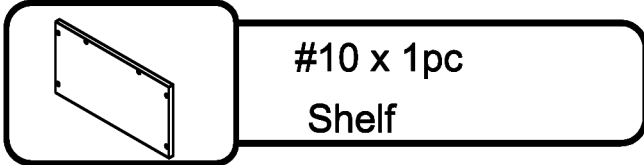

Exploded View

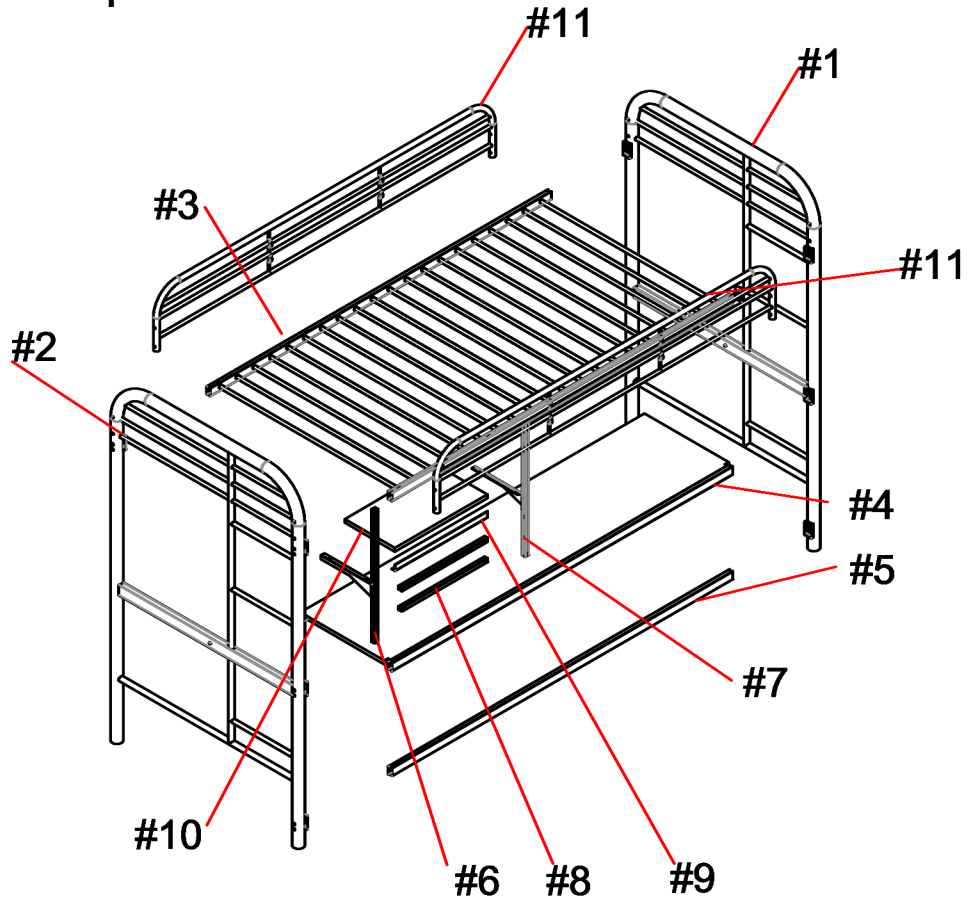

#A x 4pcs
#C x 8pcs

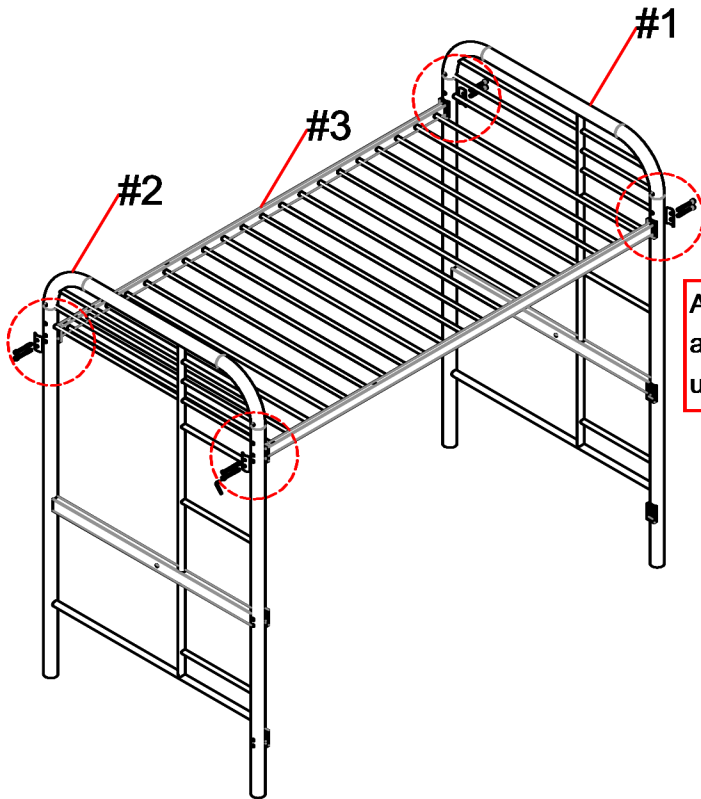

Align bed slat (#3) to the holes of the left and right headboard (#1,2). Secure by using bolts (#C) with washers (#A).

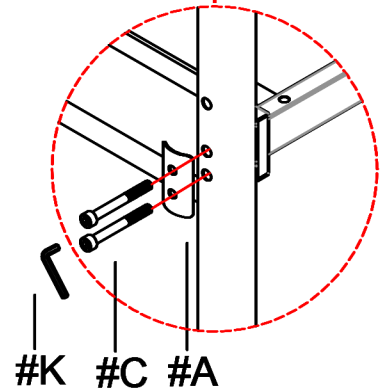



Align desk top (#4) to the holes of the left and right headboards (#1,2).

#A x 2pcs
#C x 4pcs
#F x 2pcs
#Jx 2pcs

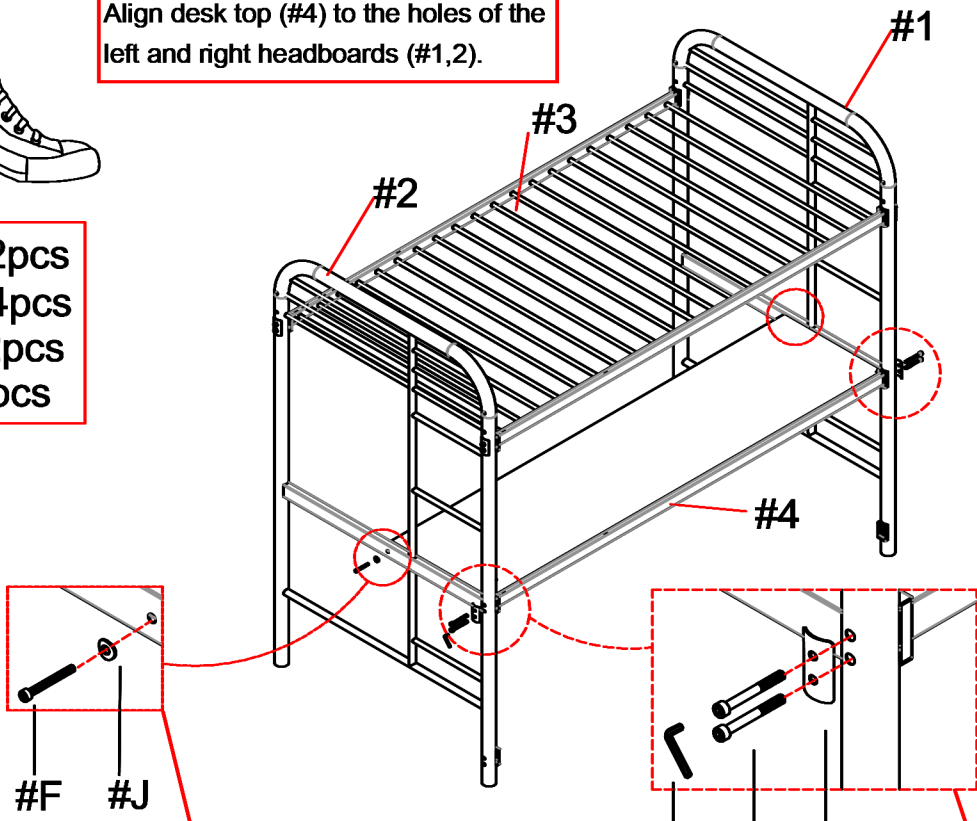

Secure by using bolts (#F) with washers (#J).

#L #C #A

Secure by using bolts (#C) with washers (#A).



#A x 2pcs
#C x 4pcs

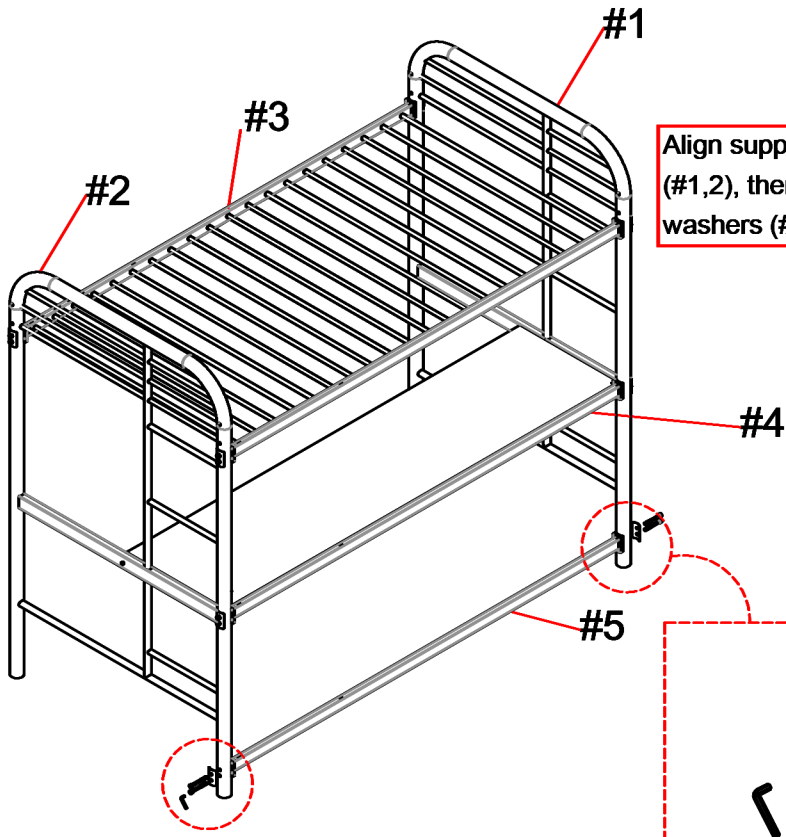

Align support bar (#5) to the headboards (#1,2), then secure by using bolts (#C) with washers (#A).

#L #C #A



Align support bracket (#9) to the holes of the shelf (#10), then secure by using screws (#E).

#E x 2pcs

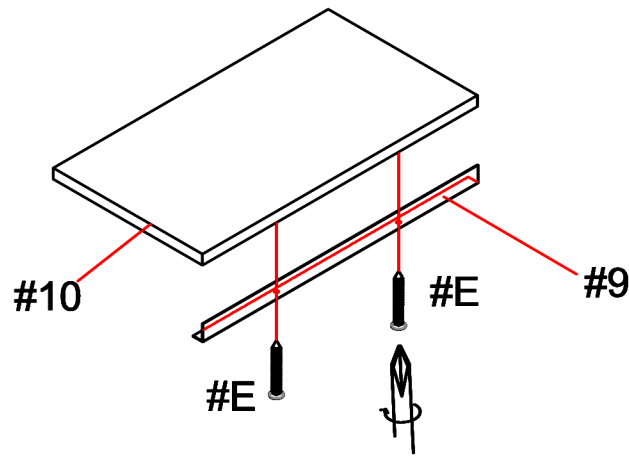

#E x 4pcs
#G x 4pcs

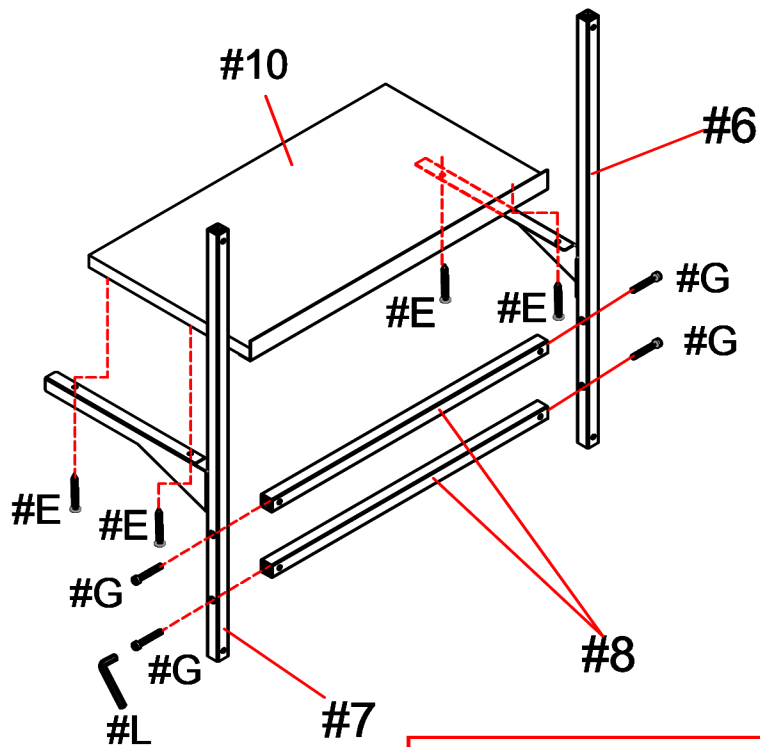

Align shelf side frames (#6,7) to the holes of the connect tubes (#8), then secure by using bolts (#G). Align shelf (#10) to side frames (#6,7), then secure by using screws (#E).



#D x 4pcs

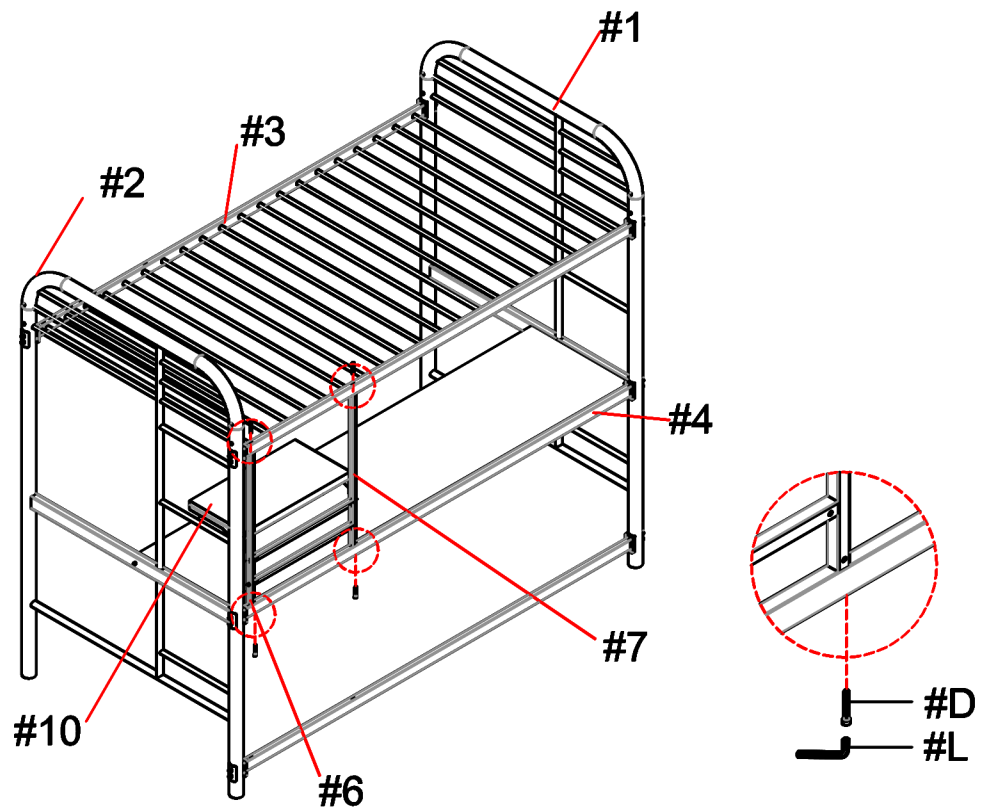

Align side frames of shelf (#6,7) to the holes, then secure by using bolts (#D).



#B x 4pcs
#H x 4pcs
#I x 4pcs

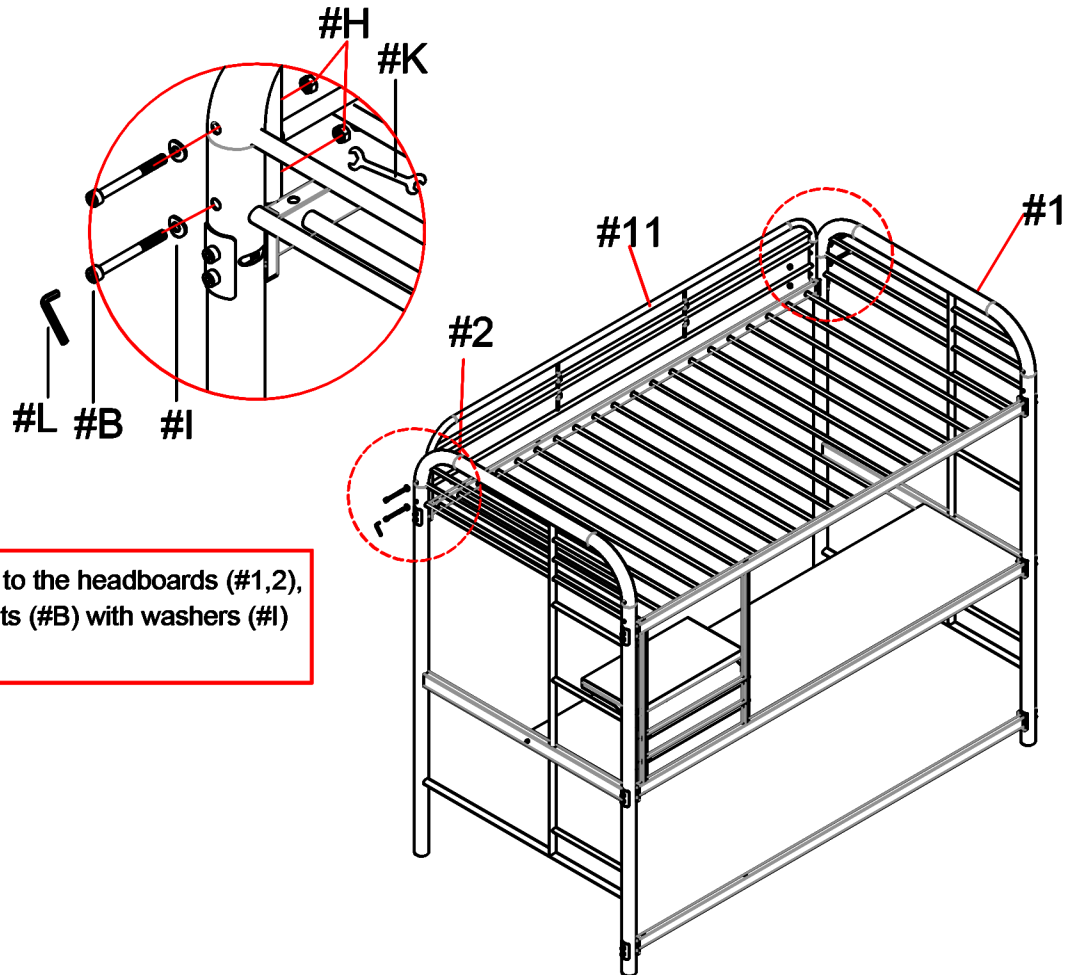

Align top guardrail (#11) to the headboards (#1,2), then secure by using bolts (#B) with washers (#I) onto hex nut (#H).



#B x 4pcs
 #H x 4pcs
 #I x 4pcs

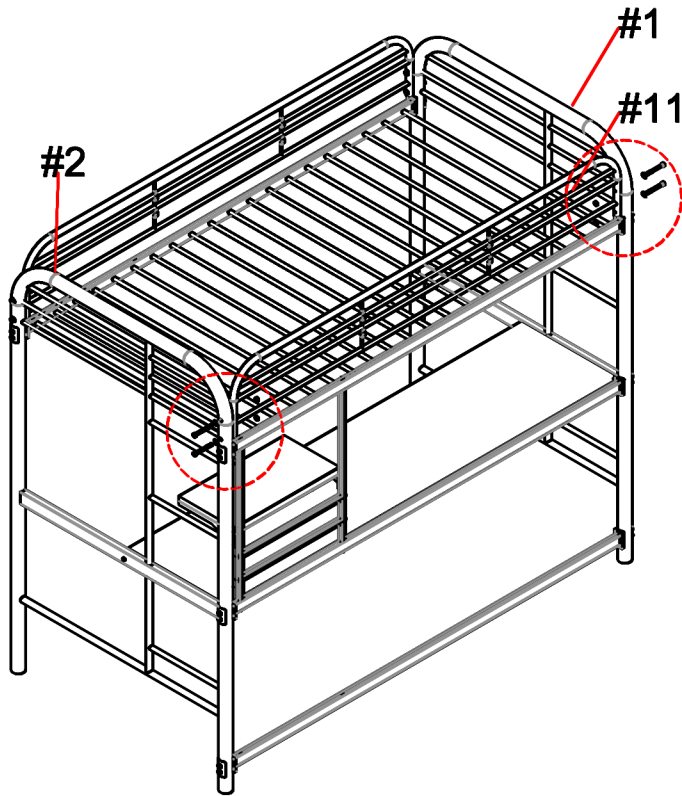

Align top guardrail (#11) to the headboards (#1,2), then secure by using bolts (#B) with washers (#I) onto hex nut (#H).

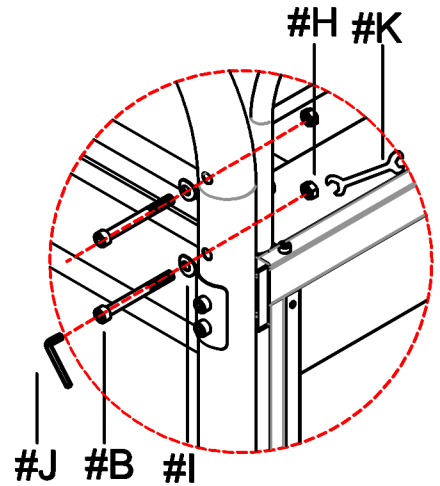

#M x 2pcs
 #N x 2pcs
 #O x 2pcs

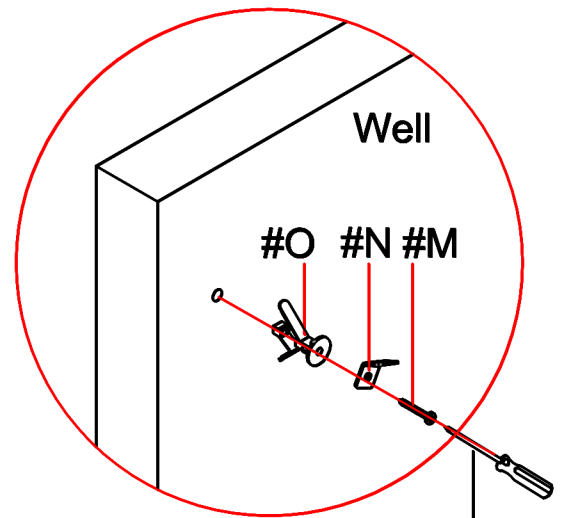
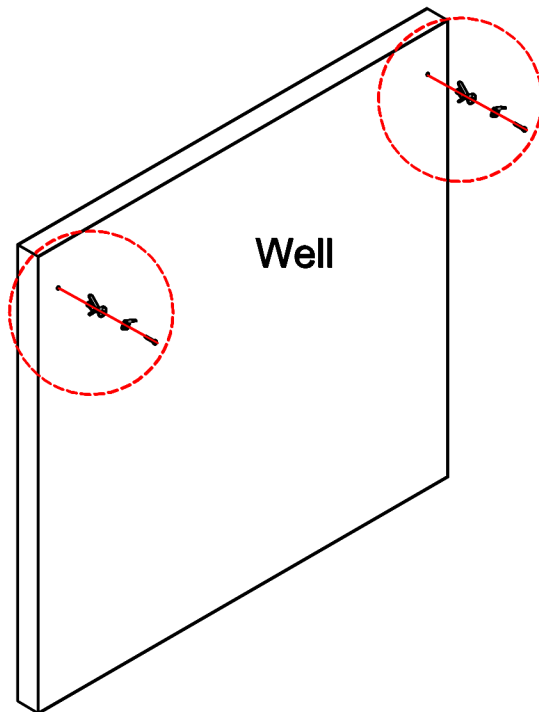

1) Place bunk bed by the wall to measure out the general area of where the wall anchor should be placed.
 2) Secure metal plate (#N) to the wall anchor (#O) by using screws (#M).

SCRE WDRIVER
 (NOT PROVIDED)



#P x 2pcs

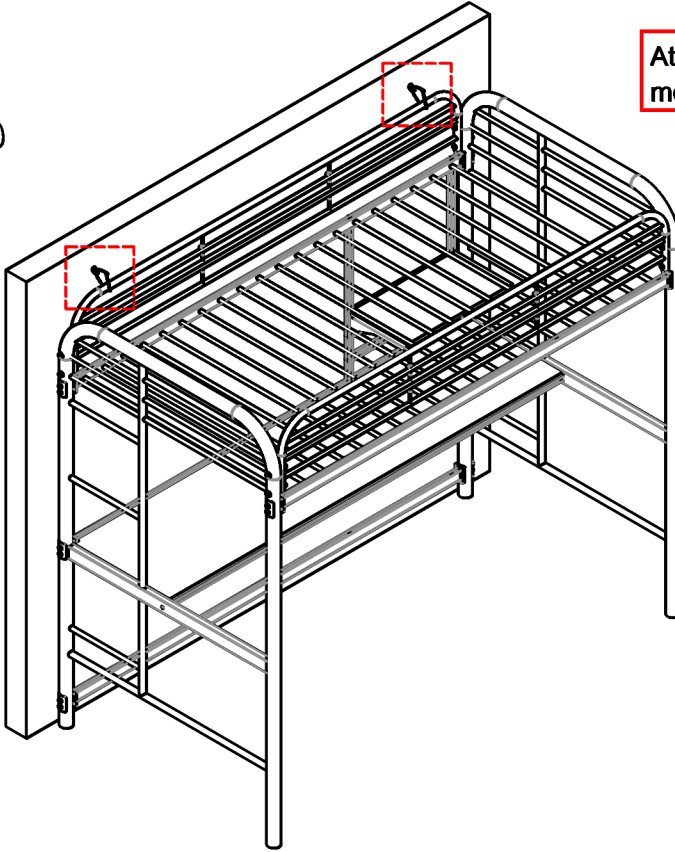

Attach the straps (#P) to the guardrail and metal plate.

