

Installation Instruction

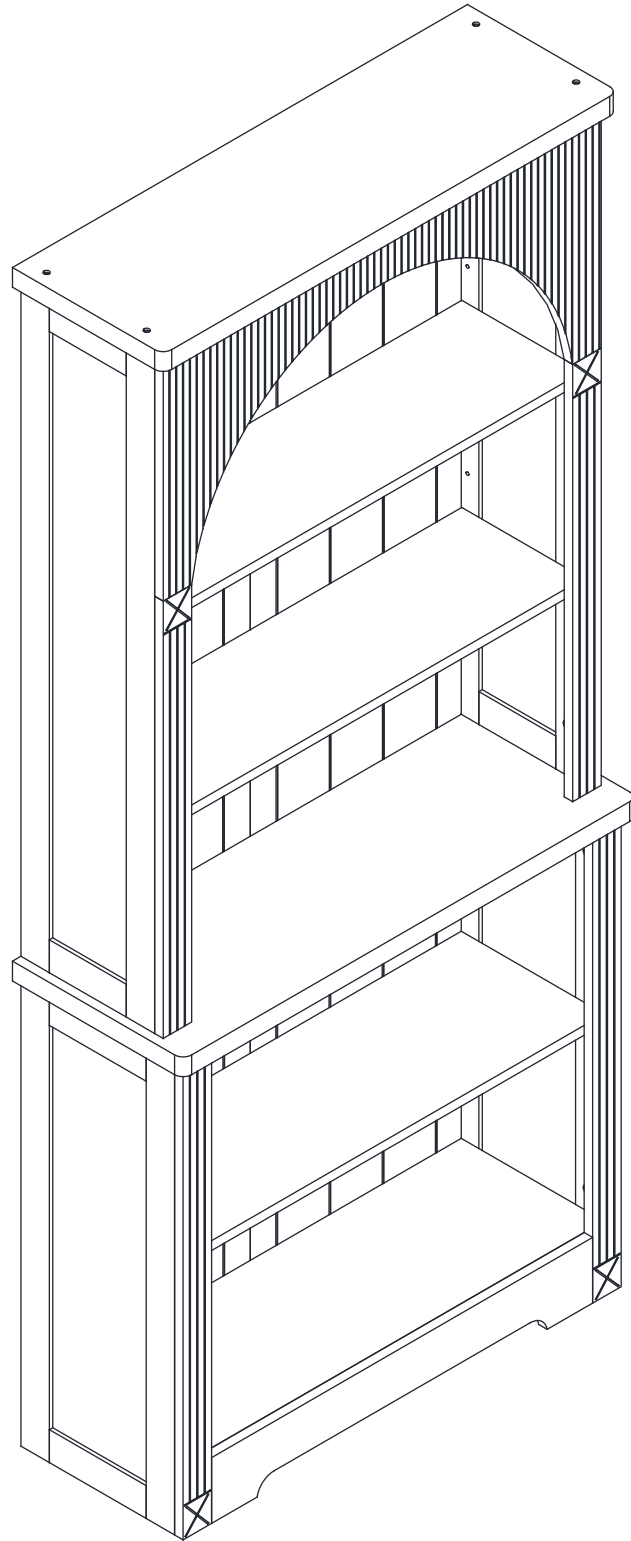

Assembling

Estimated time for assembly



40 : 00

What you need

- Use the packaging carton as a working surface to prevent product damage during assembly
- Phillips head screwdriver

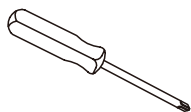

Weight Limitation



44

lbs table top

22

lbs per shelf

What's included

Code	Description	Qty
A	Cam Bolt M6X35MM	34
B	Cam Lock 15X10MM	34
C	Wooden Dowel M8X30MM	32
D	Screw M4X14MM	2
E	Screw M4X45MM	10
F	Screw M3X14MM	16
G	Metal Support	12
H	Metal Plate	2
I	Plastic Corner Support	16
J	Anchor M6X30MM	2

The Hardware

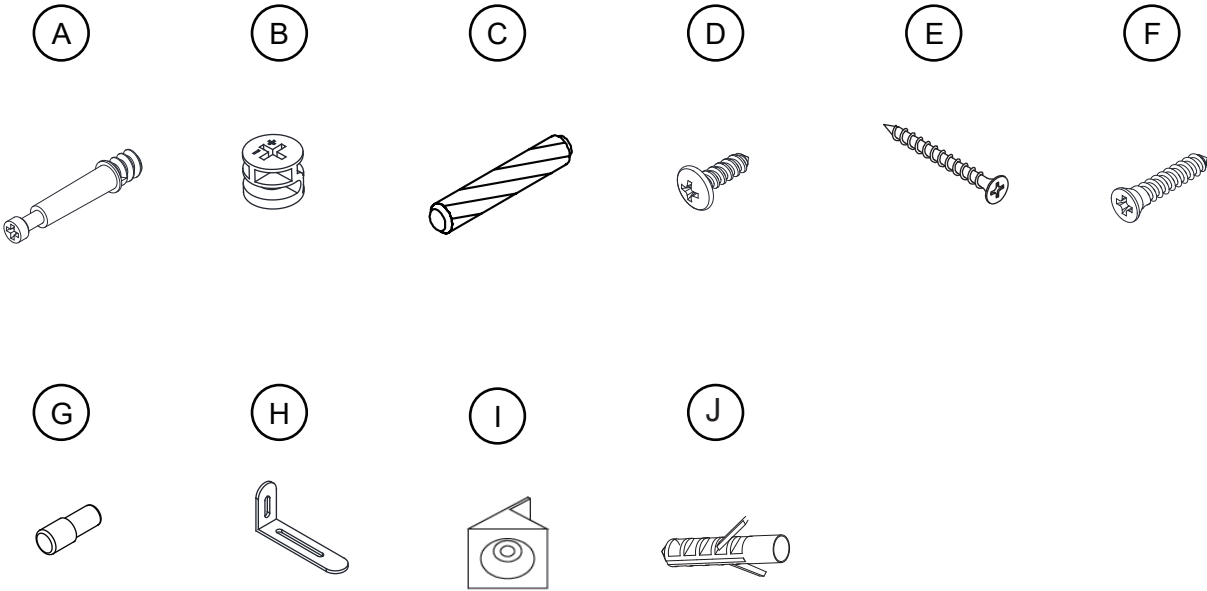

IMPORTANT:

1. Do not tighten bolts / screws completely until all bolts / screws are lined up and inserted into holes.
2. Do not over tighten screws and bolts to avoid stripping.
3. Please use hand tools to assemble this product. Do not use power tools.

Included Accessories

Code	Description	Qty
1	Cabinet Top	1
2	Top Left Side Panel	1
3	Top Right Side Panel	1
4	Middle Horizontal Panel	1
5	Top Shelf	2
6	Back Stretcher	2
7	Top Back Panel	1
8	Lower Back Panel	1
9	Top Front Panel	1
10	Middle Left Front Panel	1
11	Middle Right Front Panel	1
12	Lower Left Side Panel	1
13	Lower Right Side Panel	1
14	Bottom Panel	1
15	Lower Shelf	1
16	Lower Left Front Panel	1
17	Lower Right Front Panel	1
18	Bottom Front Panel	1

The Accessories

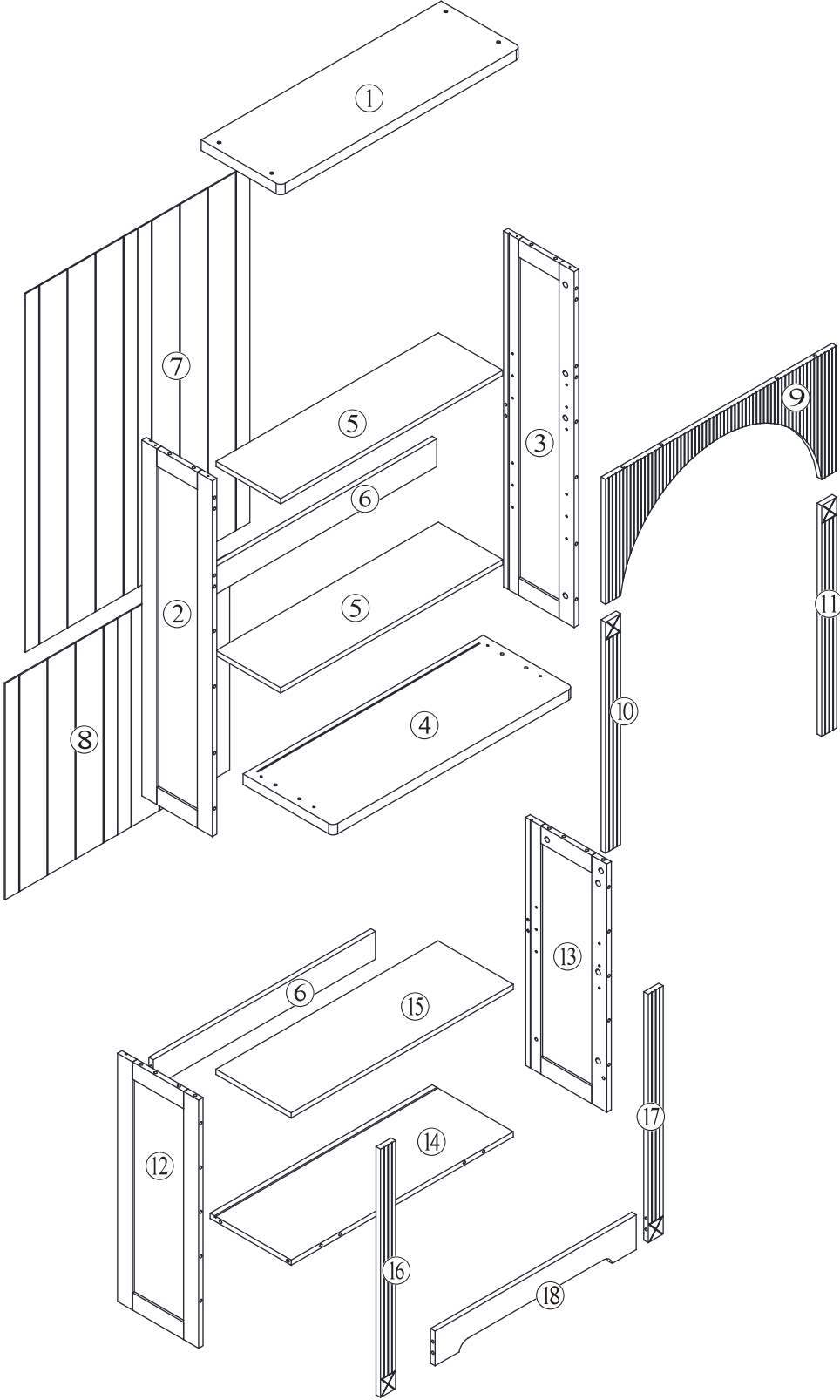

Step 1

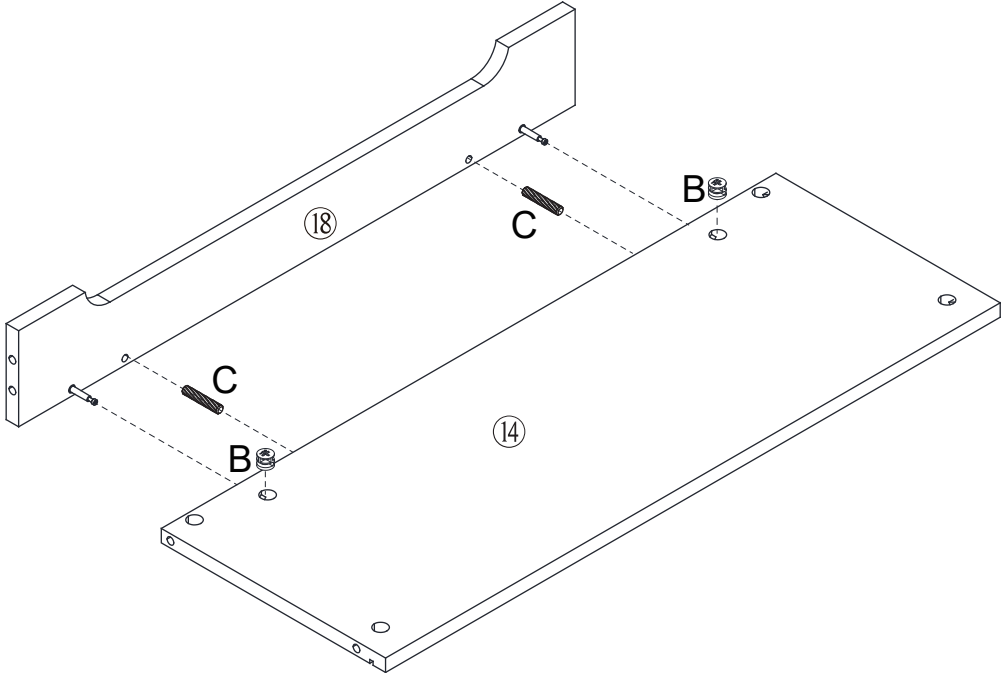
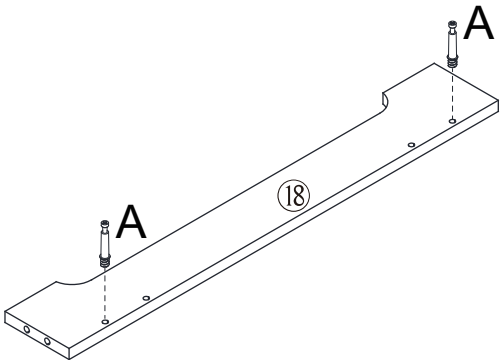
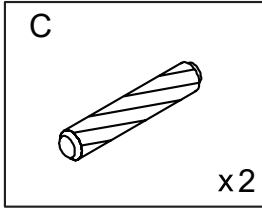
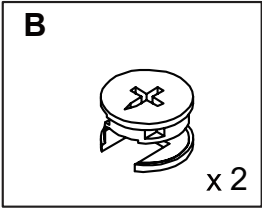
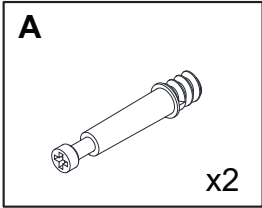

Step 2

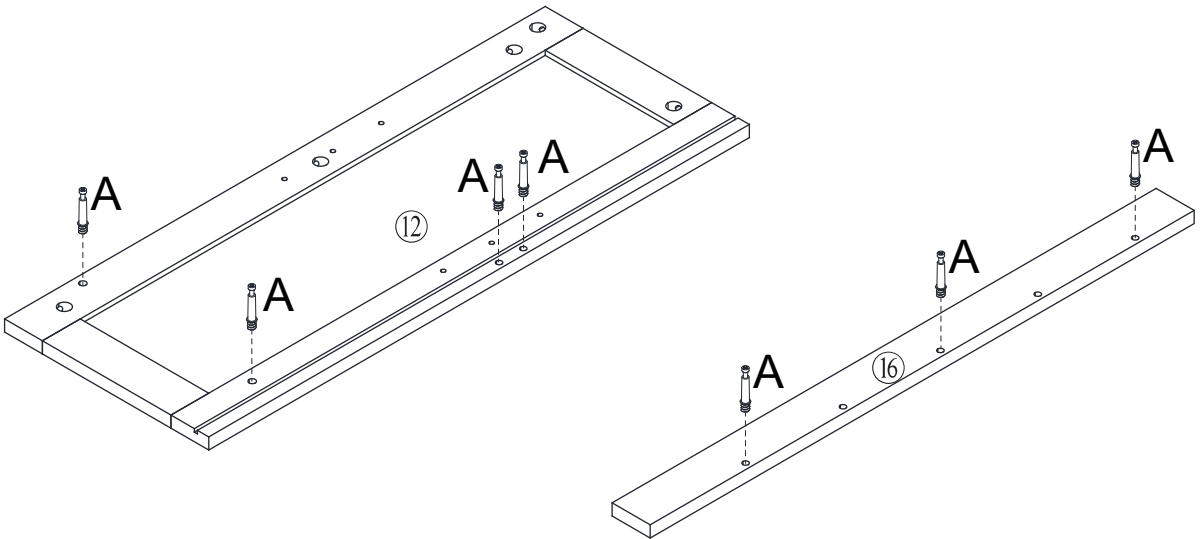
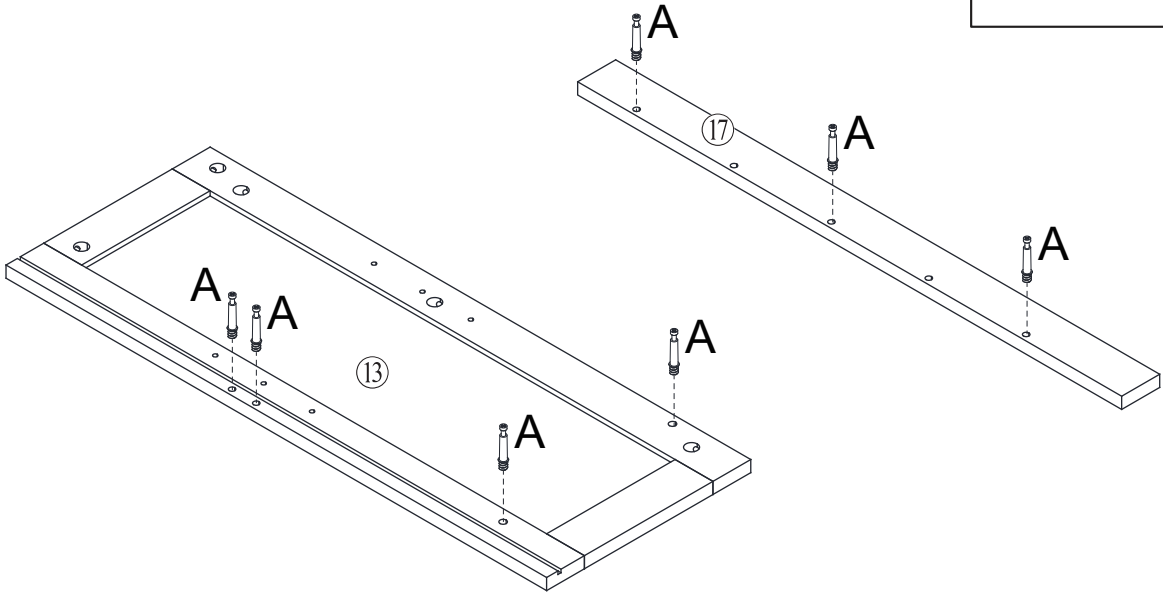
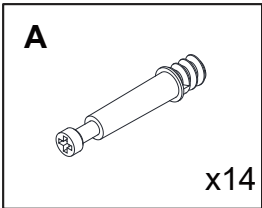

Step 3

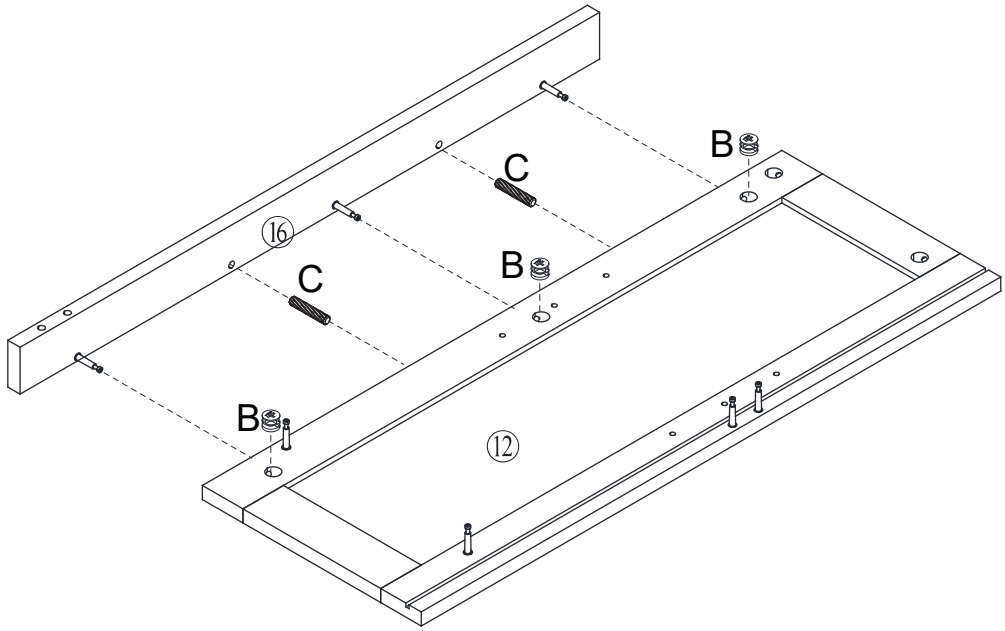
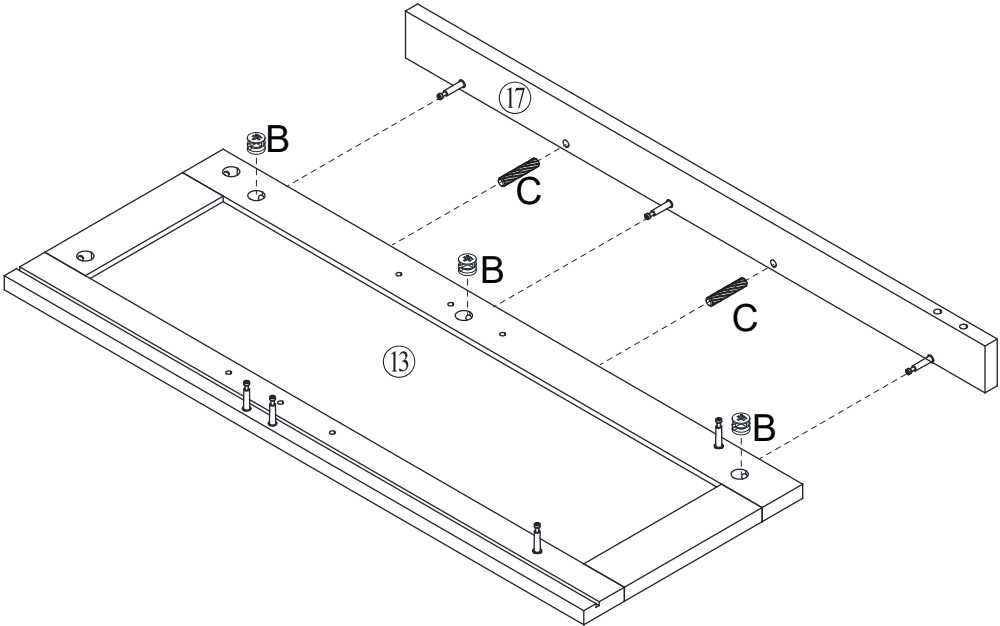
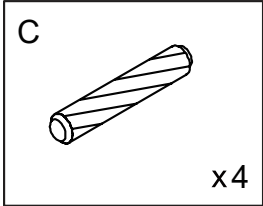
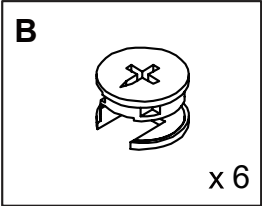

Step 4

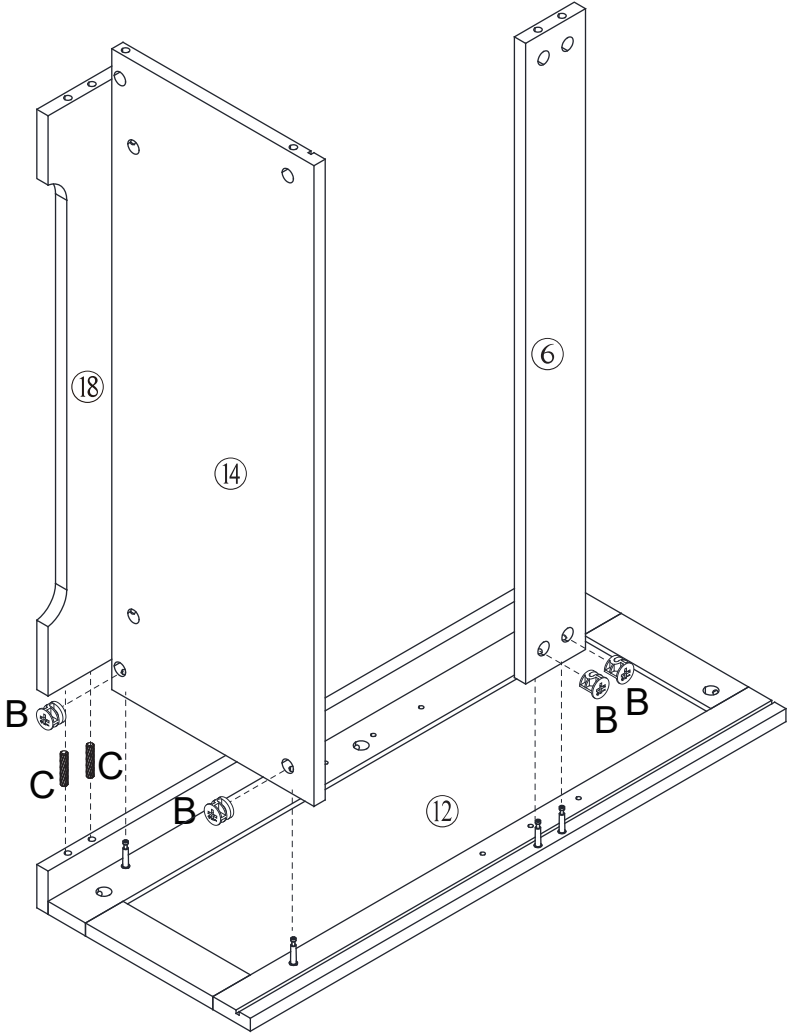
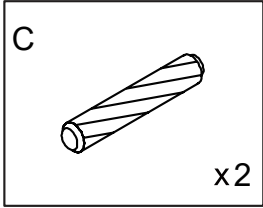
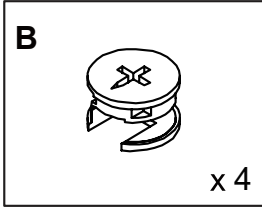

Step 5

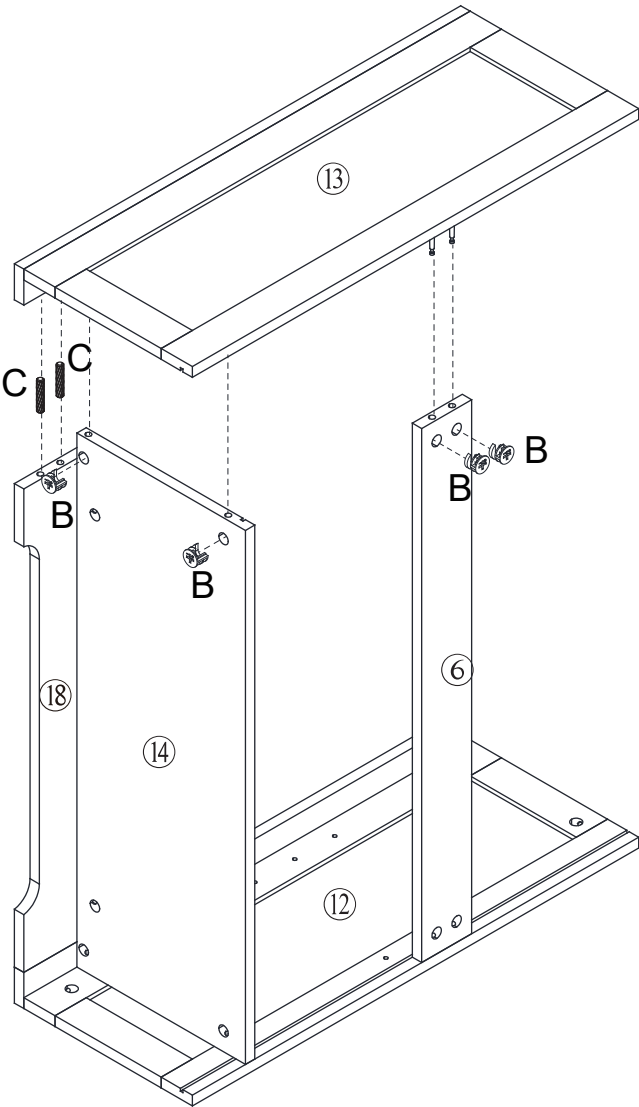
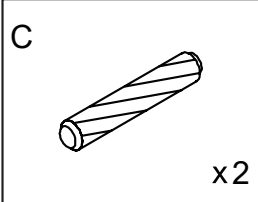

Step 6

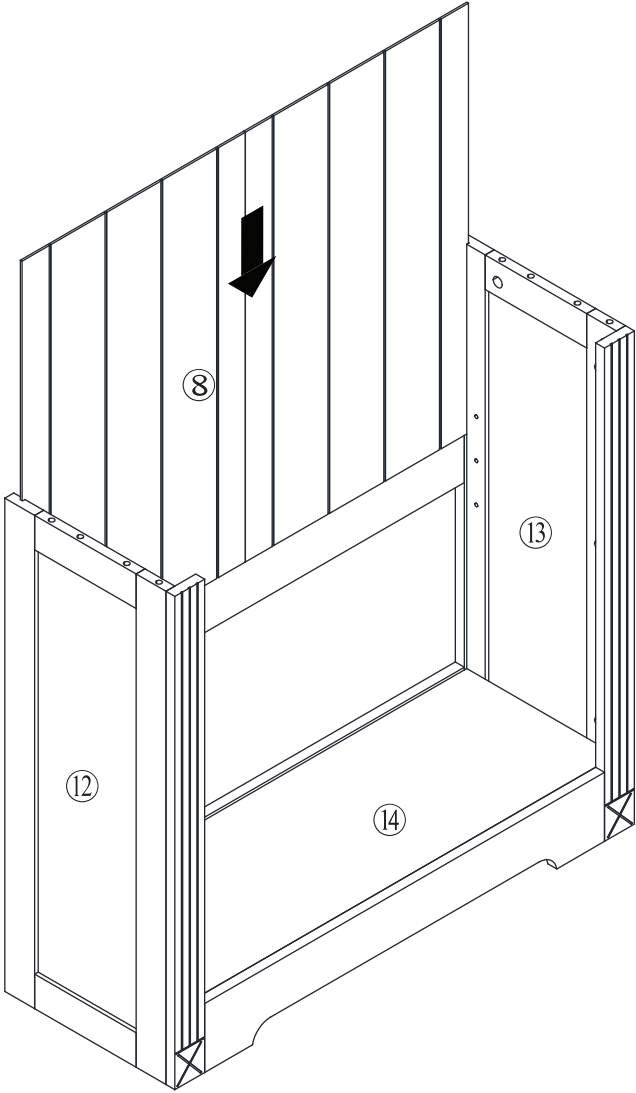

Step 7

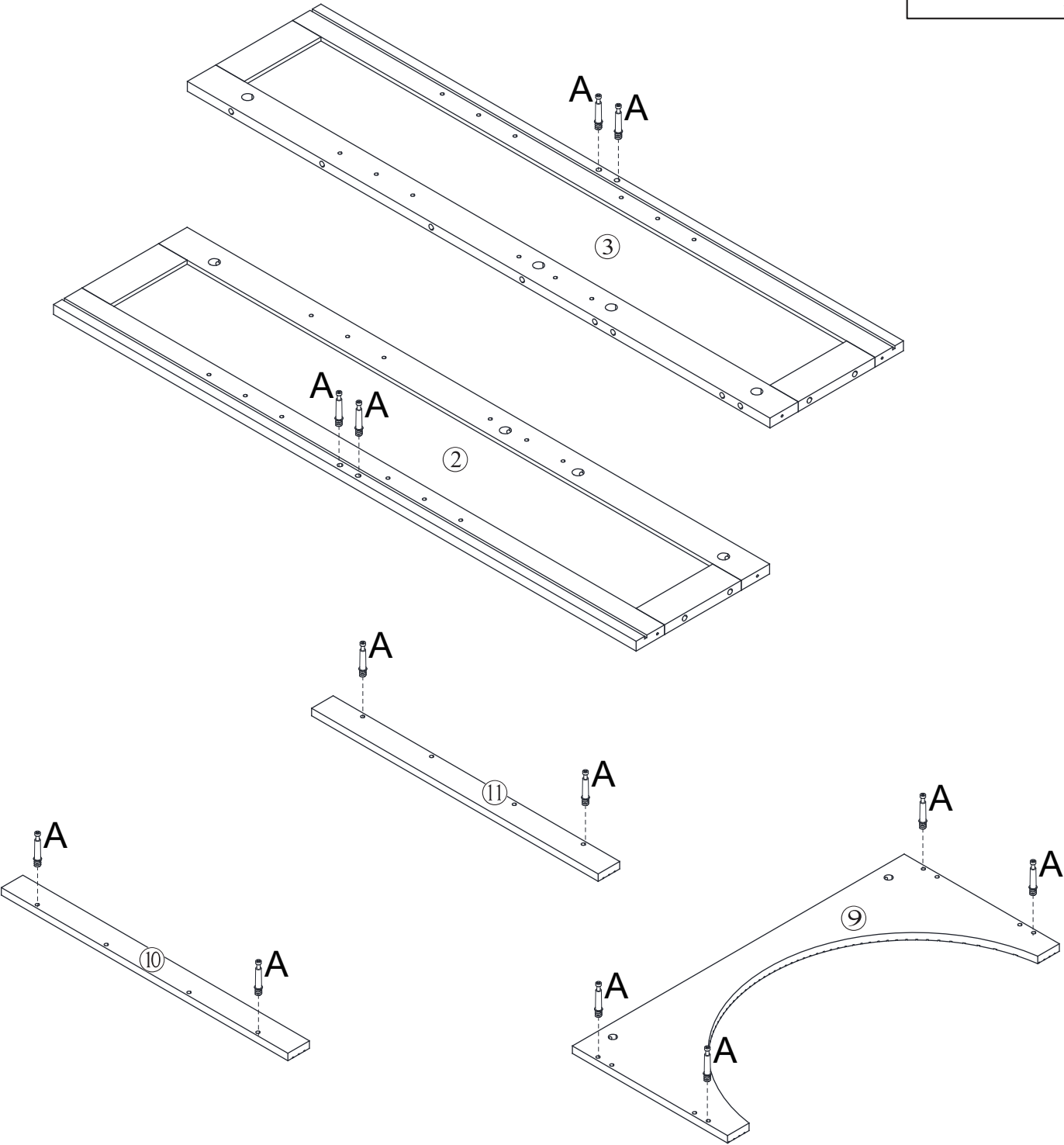
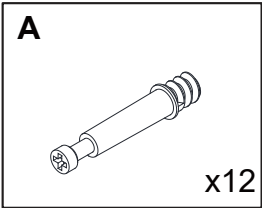

Step 8

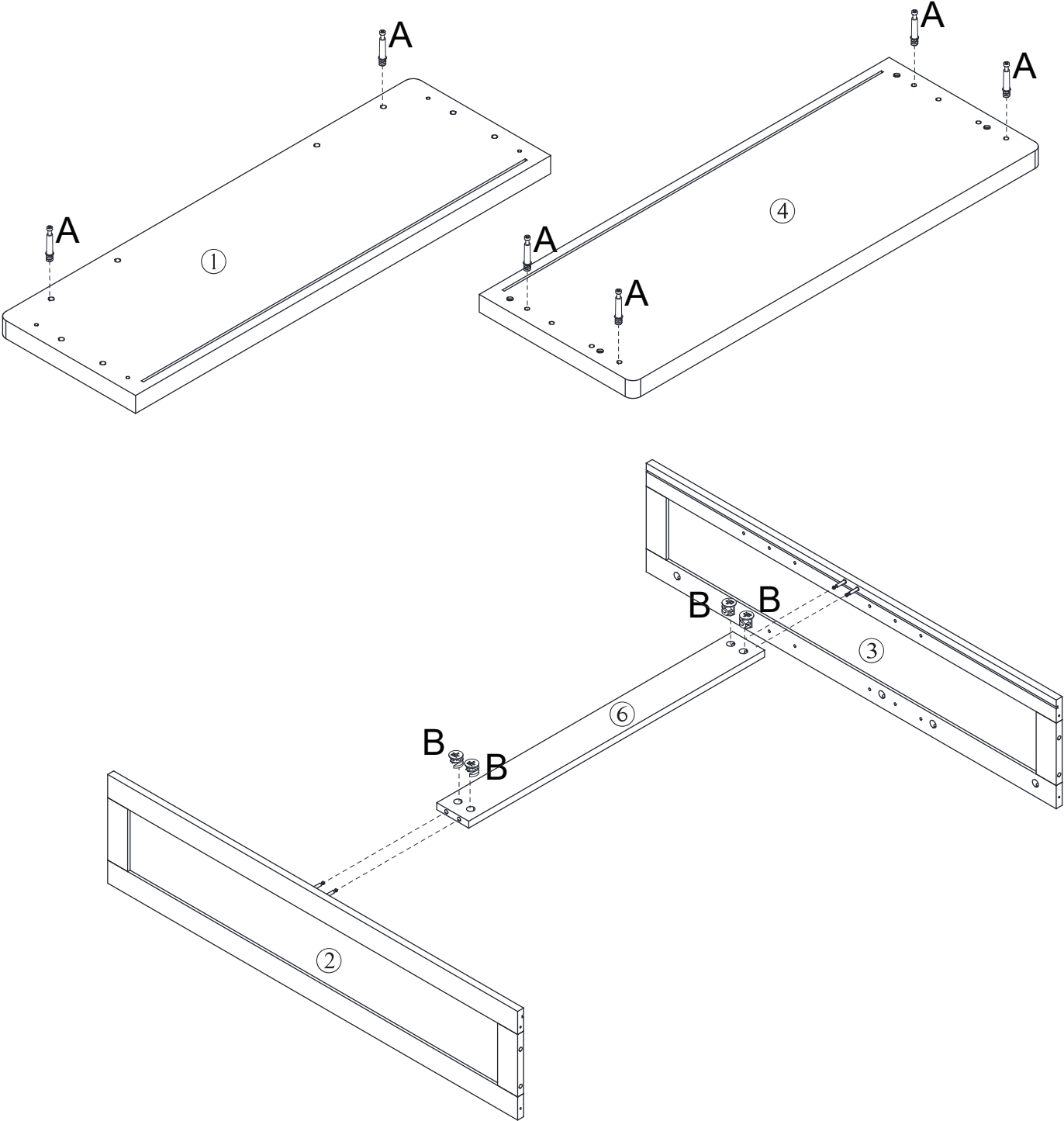
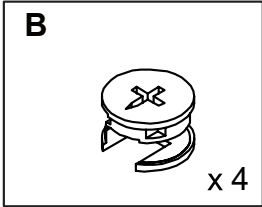
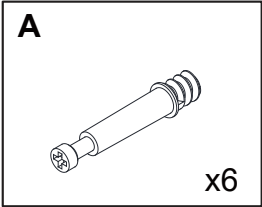

Step 9

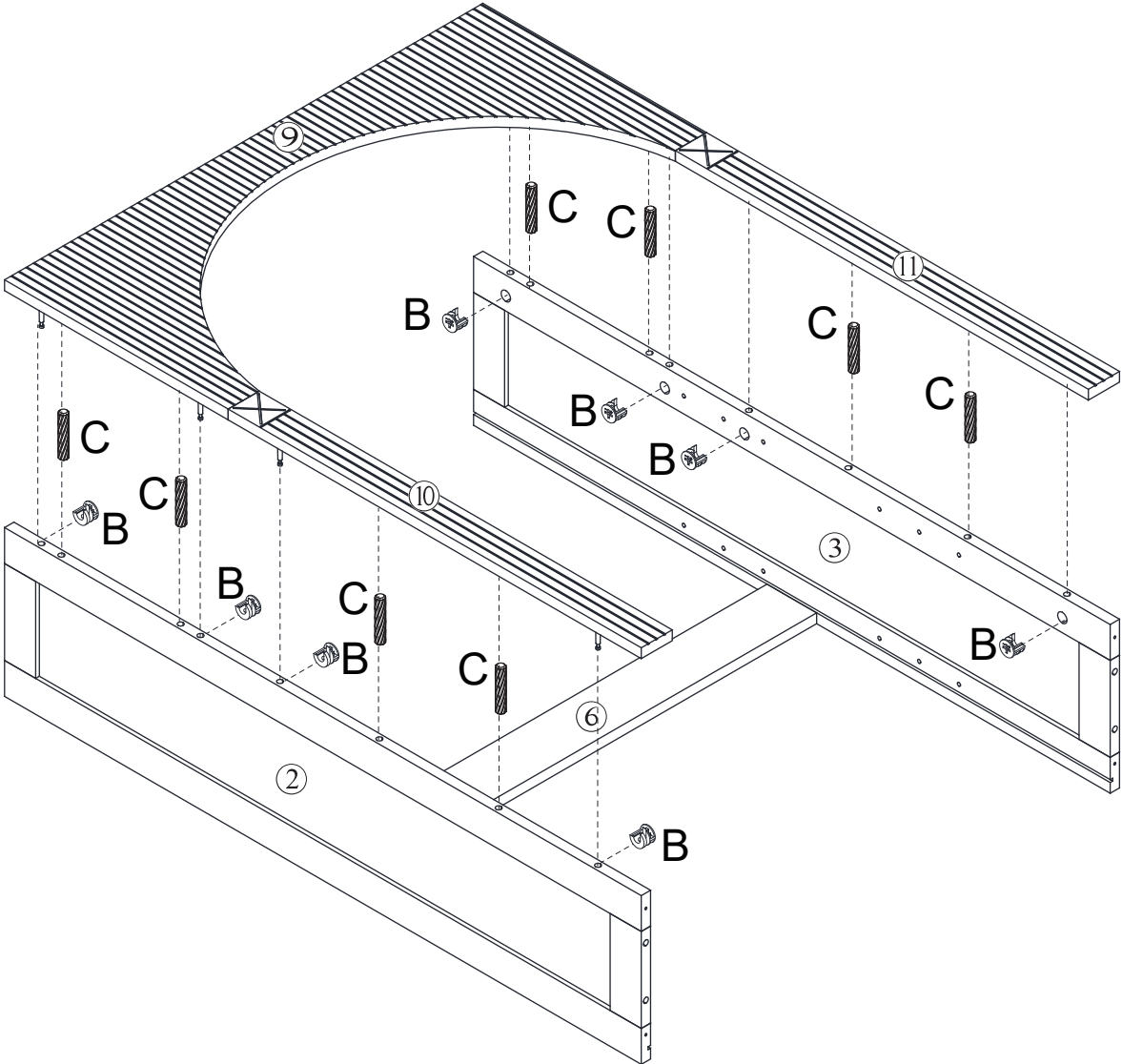
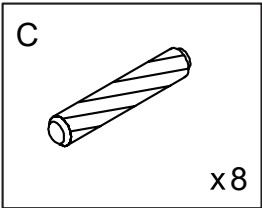
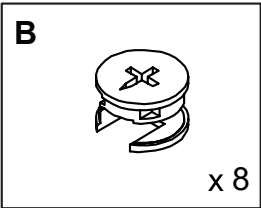

Step 11

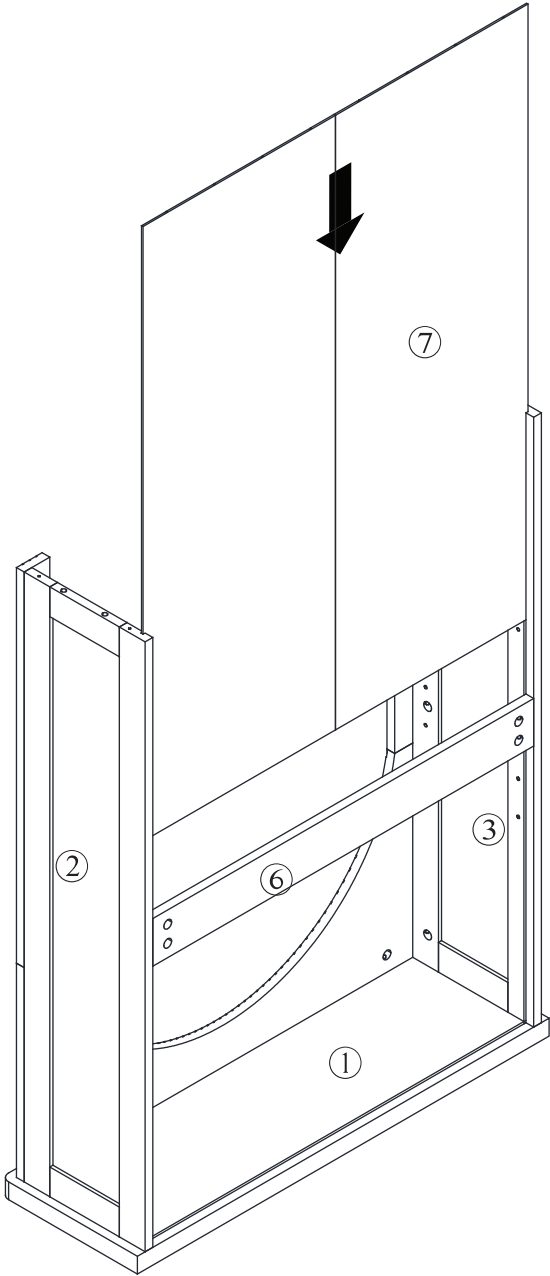

Step 12

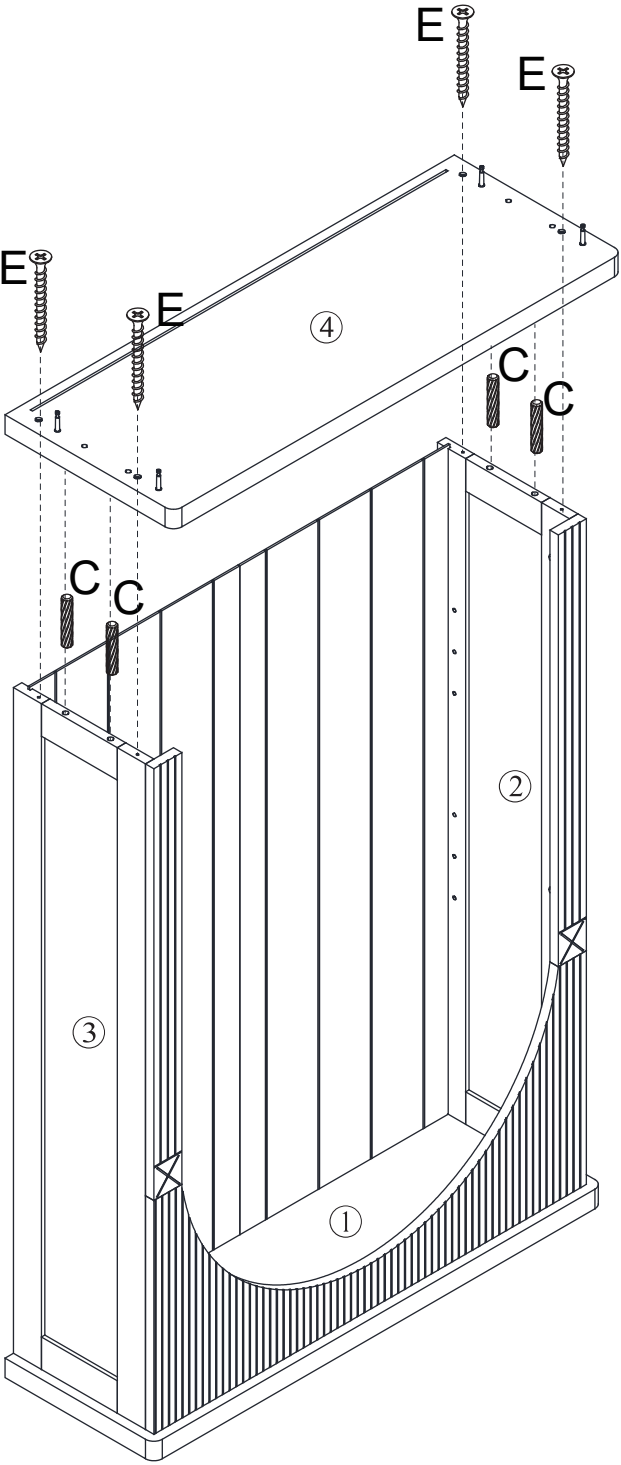
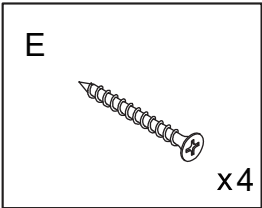
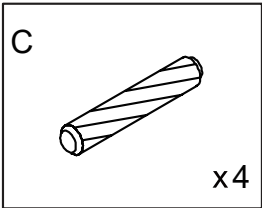

Step 13

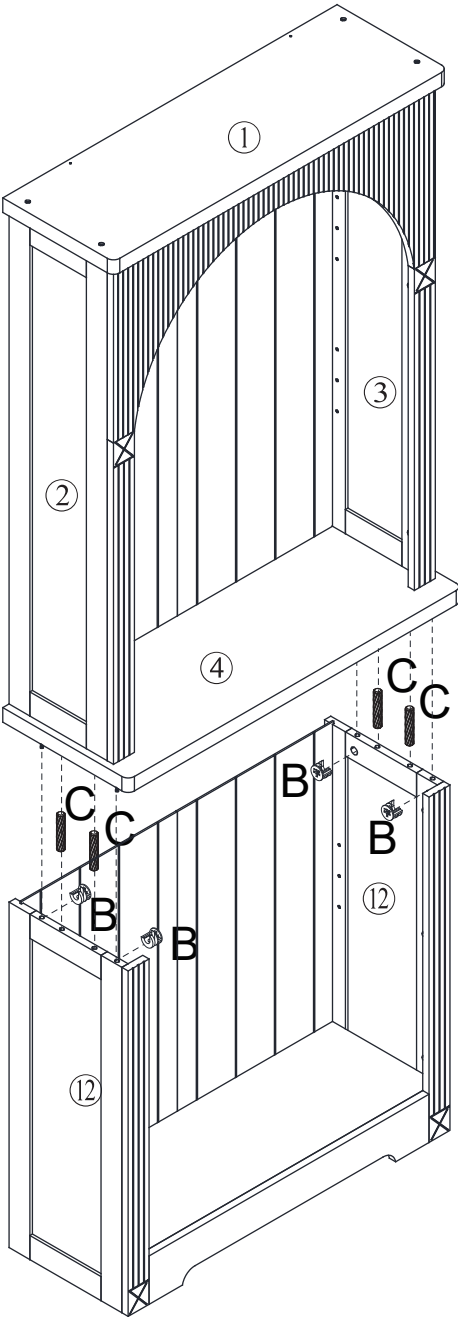
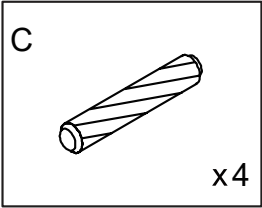
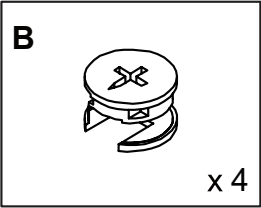

Step 14

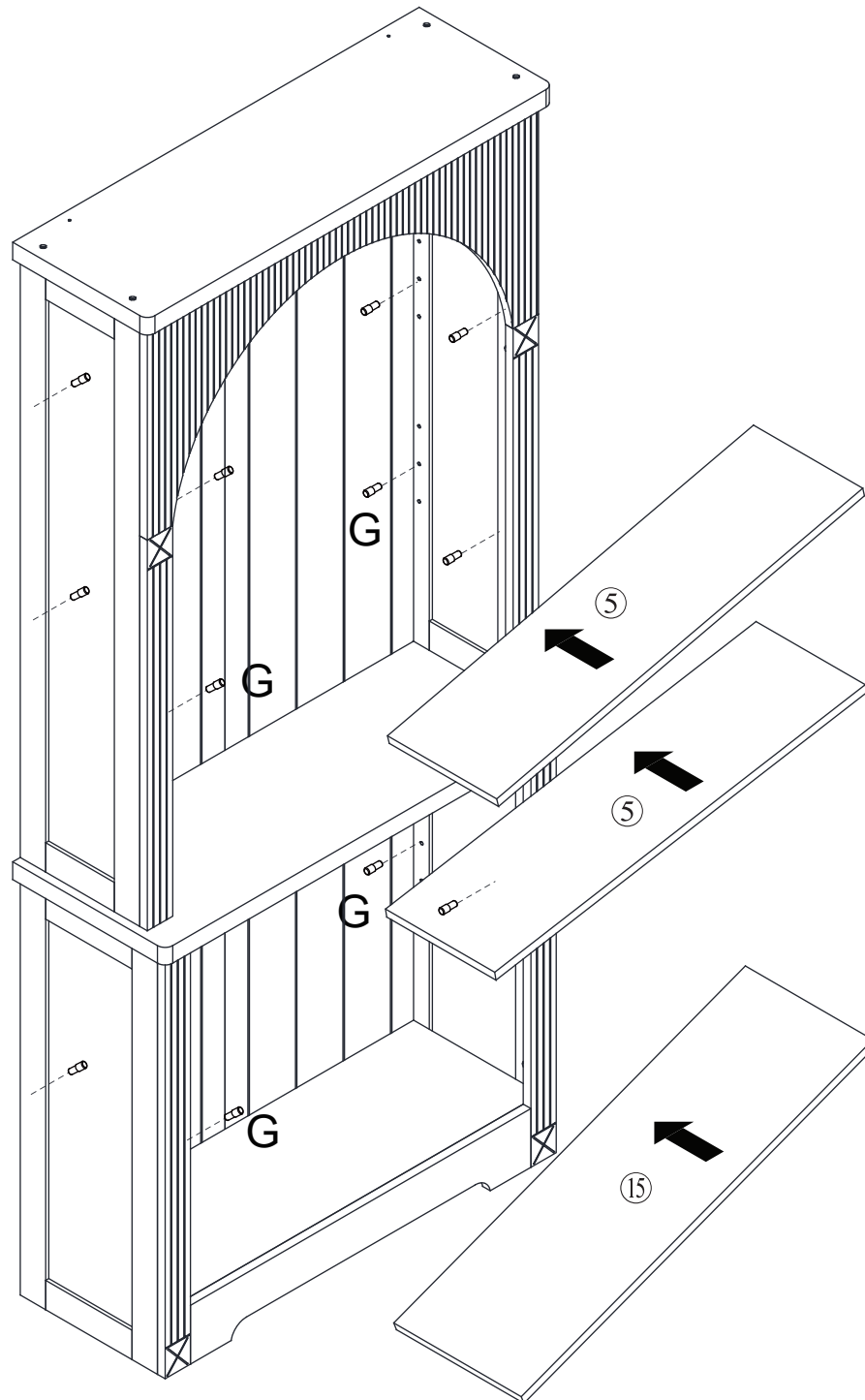
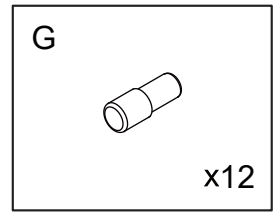

Step 15

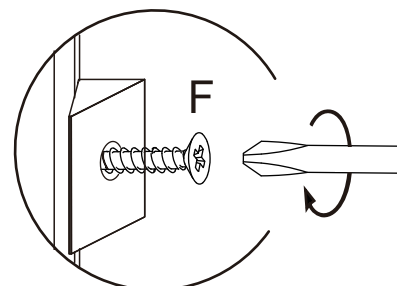
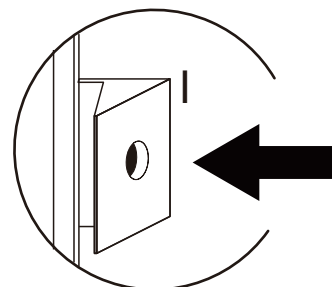
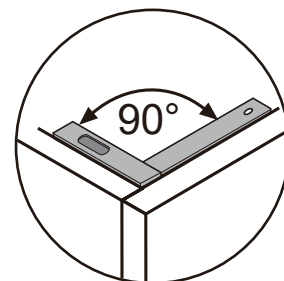
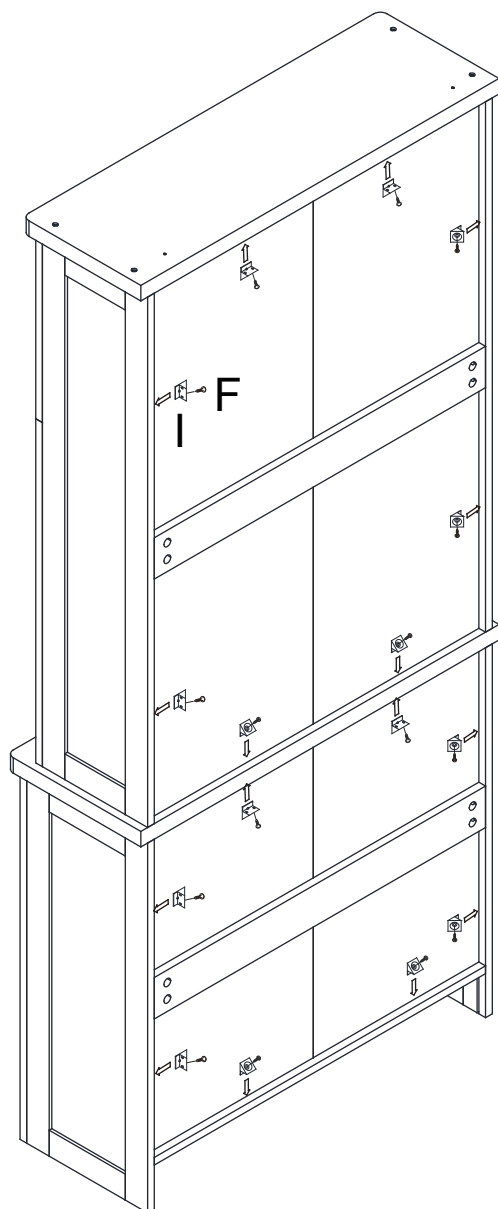
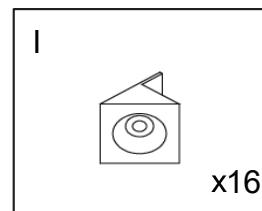
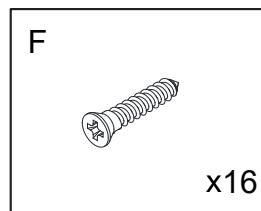

Step 16

