

Assembly Instructions

Craft Storage Organizer HOU764

Note: Please follow the instructions for more convenient installation.

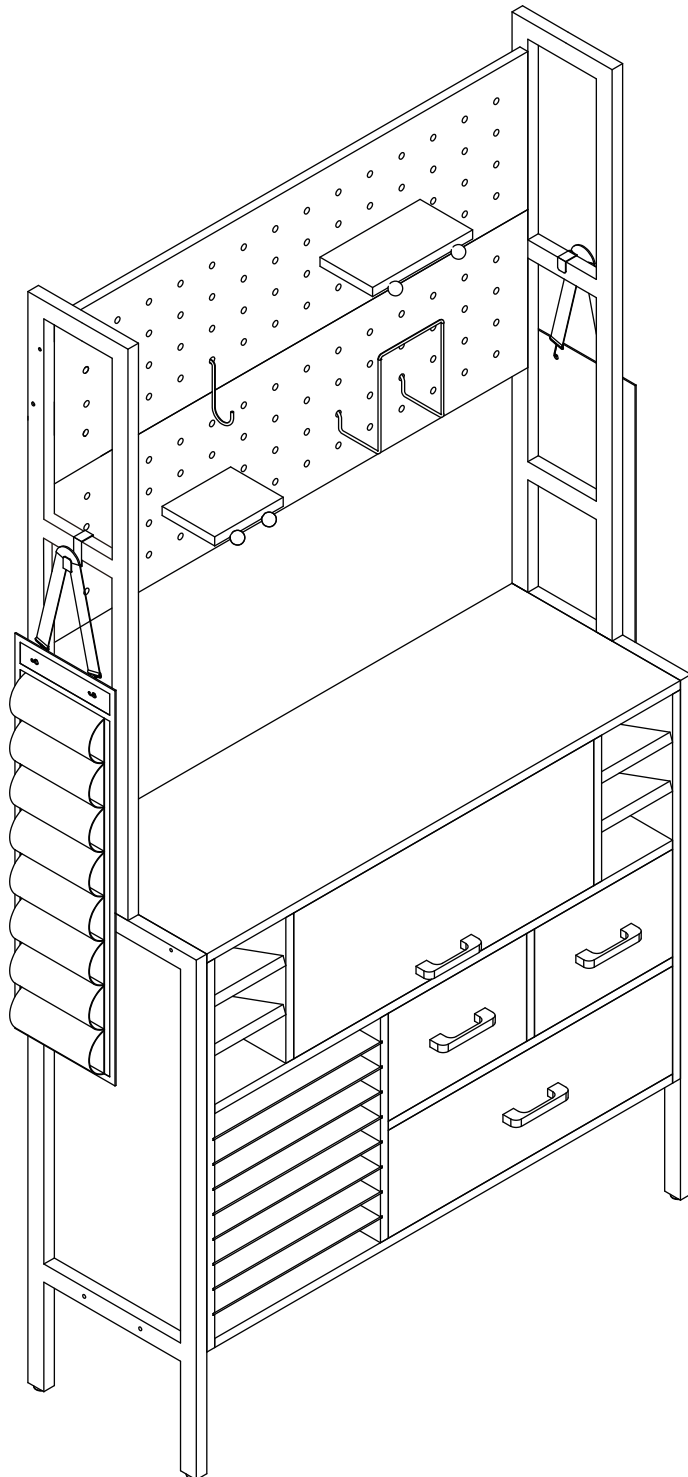

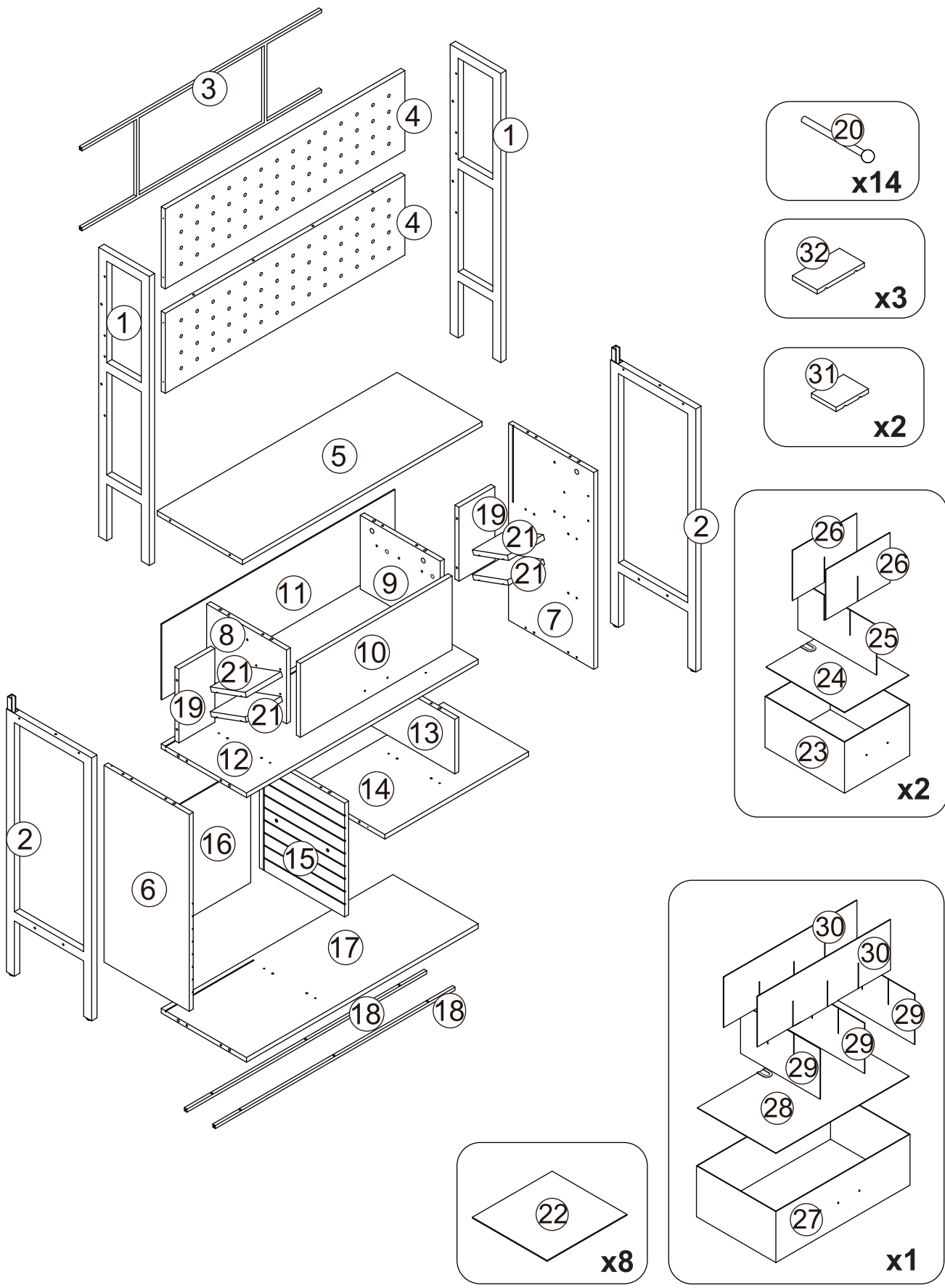

A	x20(+1)	B	x20(+1)	C	x46(+3)	D	x10(+2)	E	x2	F	x1	G	x1
								E-1 E-2 		F-1 F-2 		G-1 G-2 	
Ø6×35mm		Ø15×10mm		Ø6×30mm		Ø4×35mm		Ø3.5×12mm		Ø3.5×16mm		Ø4×16mm	
H	x2	I	x16(+1)	J	x4	K	x1	L	x12(+1)	M	x1		
H-1 H-2 													
Ø3.5×14mm				Ø6×40mm		4mm		Ø5×50mm		3mm			
N	x6	O	x4	P	x15	Q	x2	R	x2	V			
		O-1 O-2 								V-1 V-2 V-3 			
Ø6×25mm		Ø3×16mm						Ø6×12mm					
S	x2	T	x4	U	x2(+2)	W	x4						
S-1 S-2 S-3 S-4 													
Ø4×35mm		Ø6×35mm											
X	x3	Y	x2										
X-1 X-2 X-3 													
Ø4×8mm		Ø6×50mm											

1 Connect parts #13 & #14 with Dowels C x2 and Screws D x2

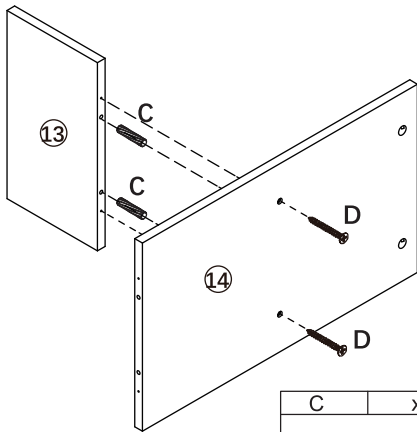

C	x2	D	x2

2 Connect Parts #14 to Part #15 using Dowels C x2 and Screws D x2

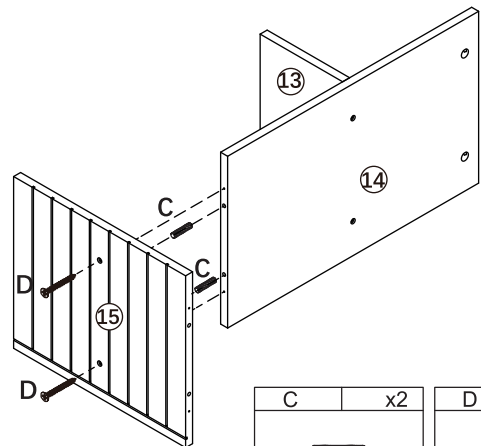

C	x2	D	x2

3 Tighten Bolts A x4 flush to Part #12 as shown

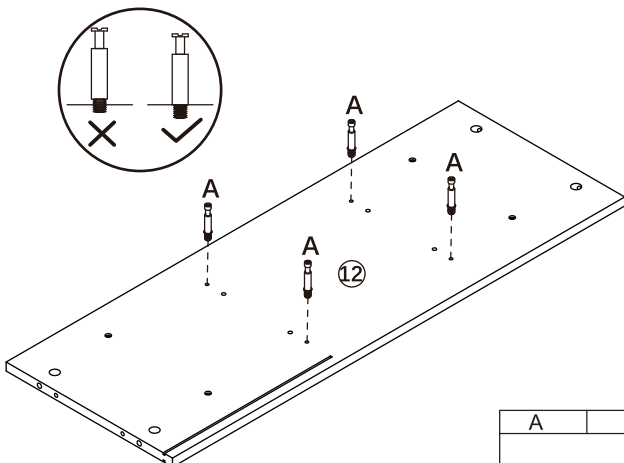

A	x4

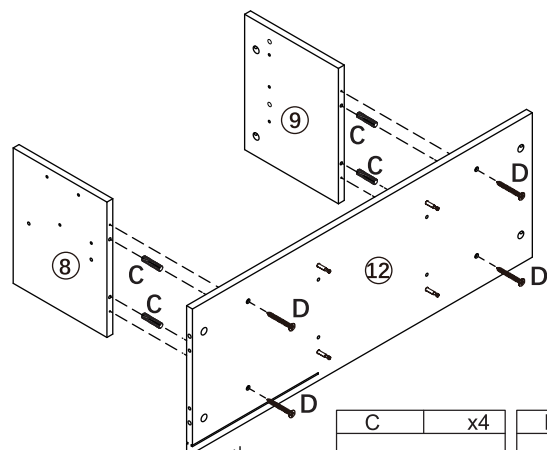

4 Connect Parts #8 & #9 to Part #12 using Dowels C x4 and Screws D x4



C	x4	D	x4

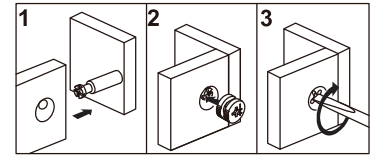
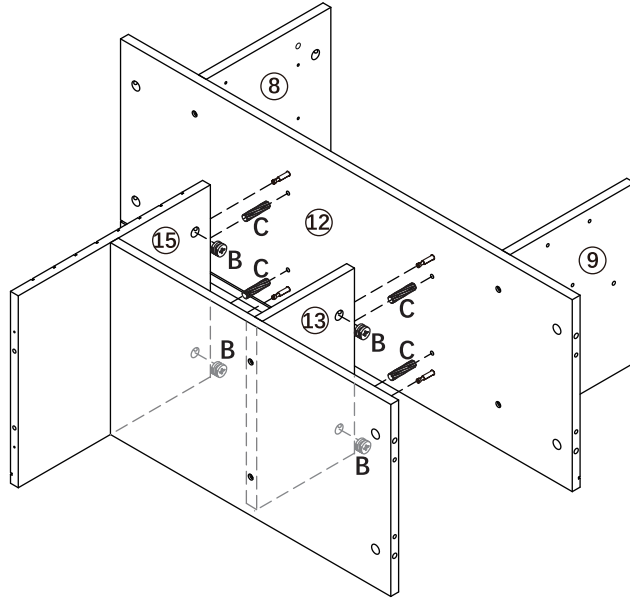

5 Connect the 2 assembled pieces(Parts 8/9/12 & Parts 13/14/15 as shown using Wooden Dowels C x4 and Connector Nut Bx4-Turn Connector Nuts to lock into place with bolts

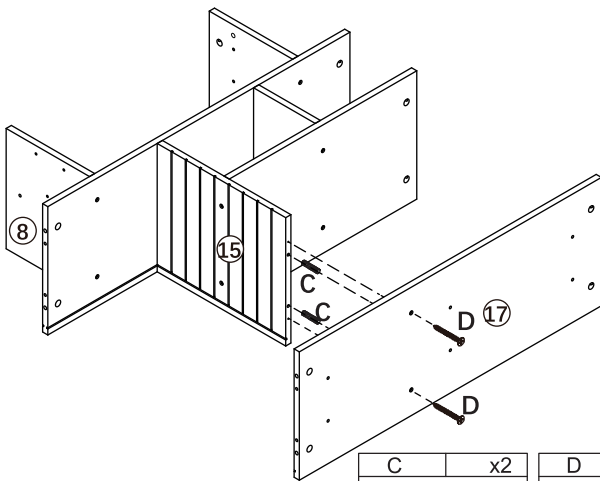

B	x4	C	x4
			

6 Attach Part #17 to Part #15 using Dowels C x2 and Screws D x2



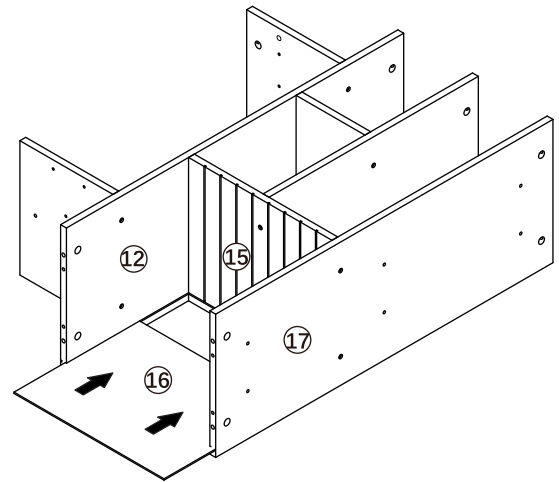

C	x2	D	x2
			

7 Insert Part #16 into grooves between Parts #17 & #12



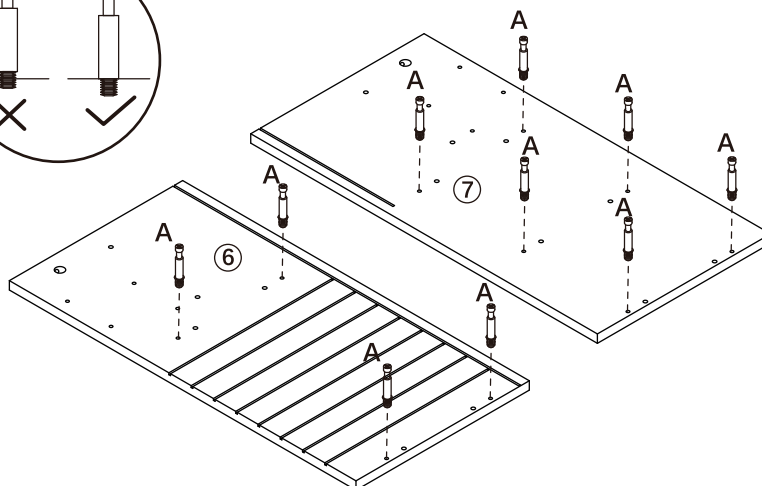
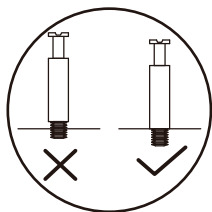

8 Insert Connector Bolts A x10 into holes in PArts #6 and #7 as shown



A	x10
	

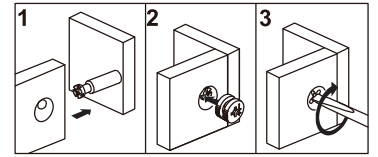
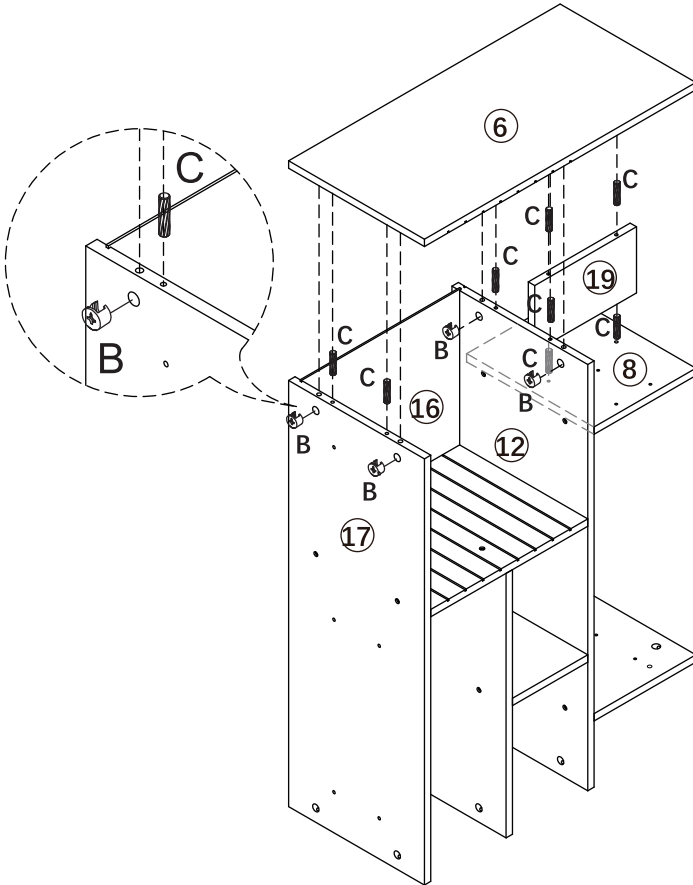

- 9** First connect Part #8 to Part #19 using wooden Dowels C x2.
Then Attach Part #6 to assembled unit as shown using Dowels x6 and Connector Nuts Bx4.
Once inserted, tighten the connector nuts to lock connection to connector bolts.

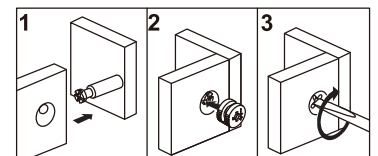
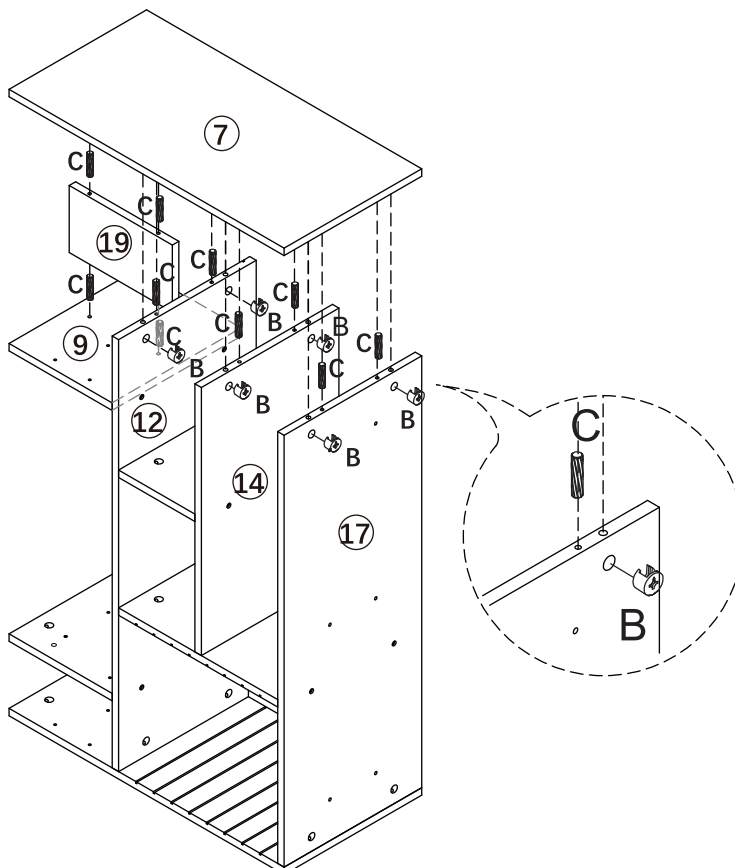

B	x4	C	x8
			

- 10** Repeat the process from Step 9 on the other Side.
First, connecting Part #9 to Part #19 with Dowels C x2.
Then attaching side Part #7 to assembled unit as shown using Connector Nut B x6 and Dowel X8



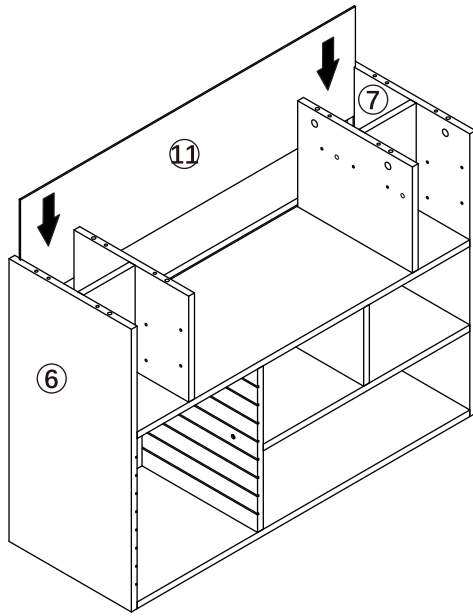

B	x6	C	x10
			

11 Insert Part #11 into Grooves between Part #6 and Part #7 as shown



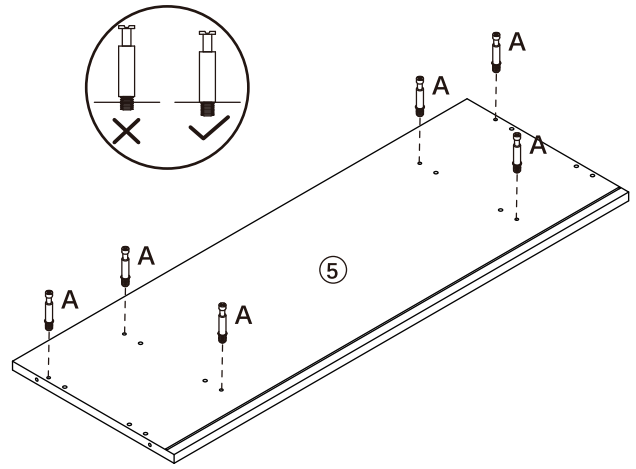



12 Insert Connector Nuts A x6 into Part #5 as shown

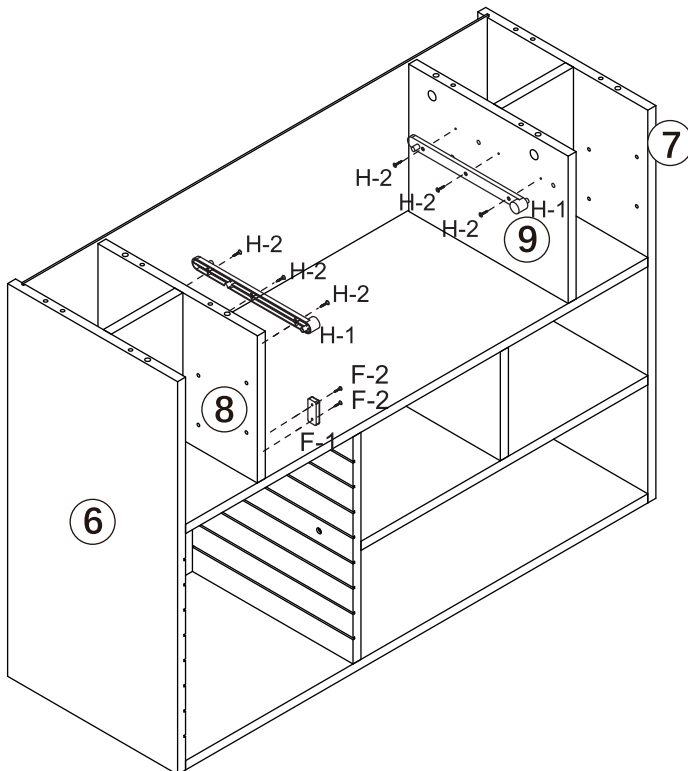

A	x6
	

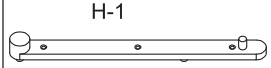
13 Instal sliding track (H-1) using screw (H-2)
Instal accessories (F-1) using screw (F-2)





H	x2	F	x1
			
			

14

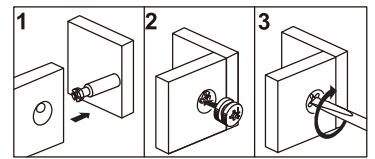
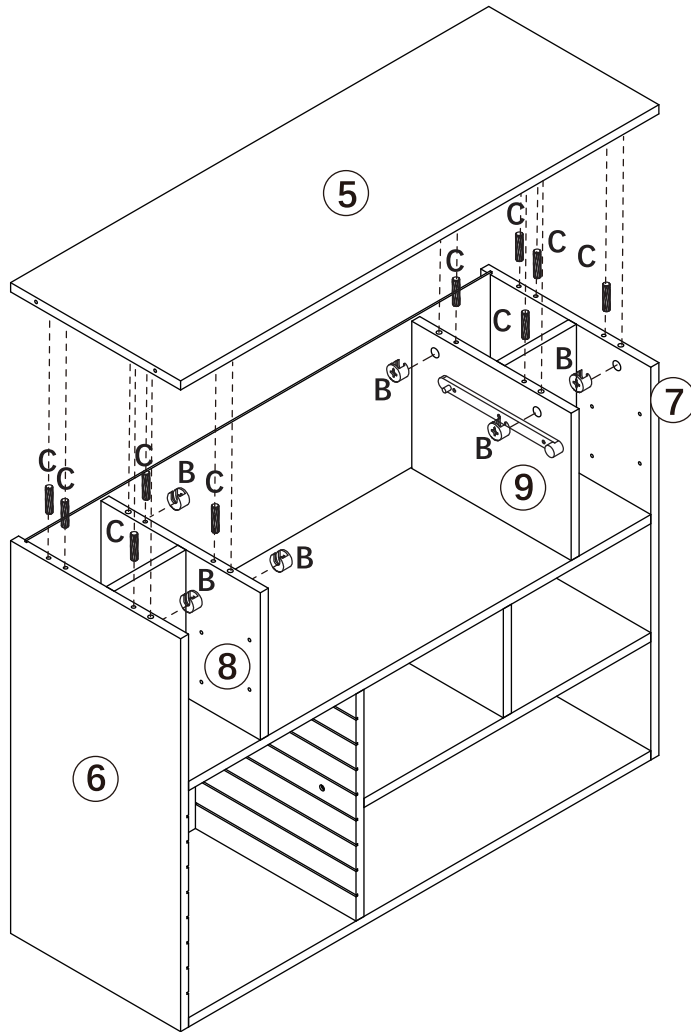
Connect Part #5 to assembled unit as shown using Wooden Dowels C x10 and Connector Nuts B x6.
Once in place tighten all connector Nuts and Bolt connections





B	x6	C	x10
			

15

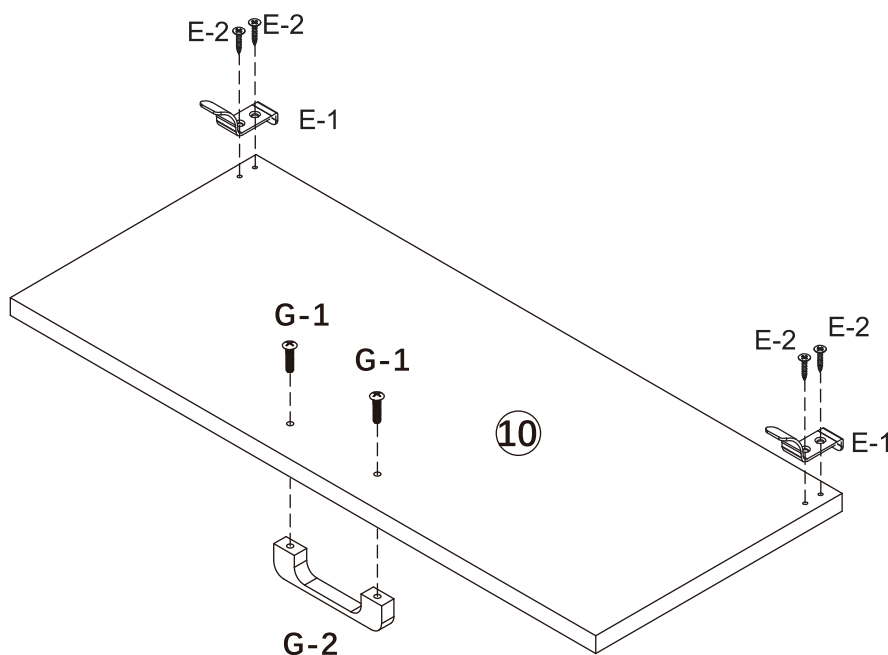
Instal the Part (E-1) using screws (E-2) and Handle (G-2) using screws G-1 on Part#10



E	x2	G	x1
E-1	E-2	G-1	G-2
			

16 Connect two Part #18 s Part #17 as shown using Bolt N x6.
Tighten with 4mm provided allen wrench K.

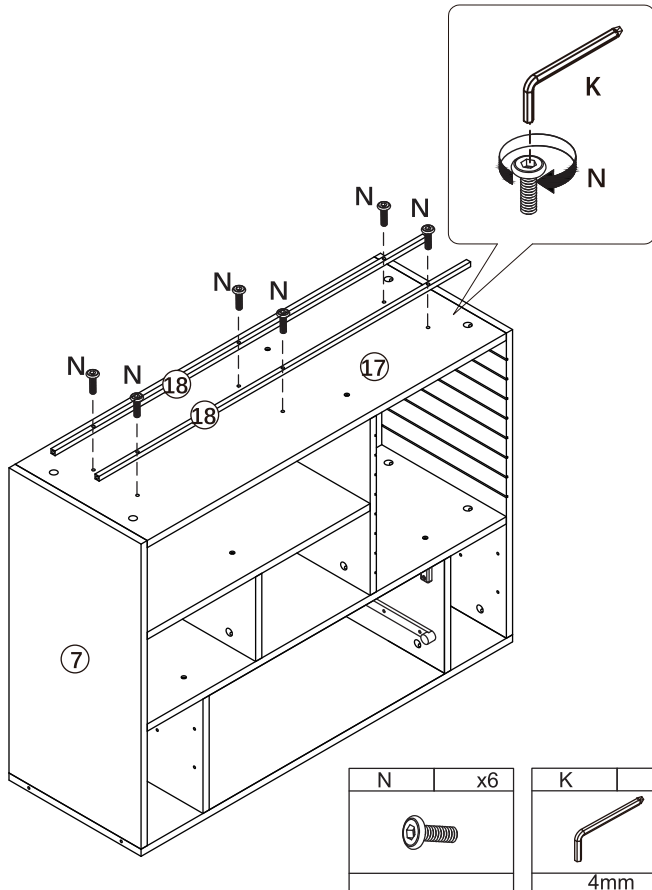

17 Install on each side Metal Legs Parts #2 as shown.
Use Bolts L on top tighten with provided 3mm Allen wrench M. Use Bolts J on bottom and tighten with provided 4mm Allen wrench K.

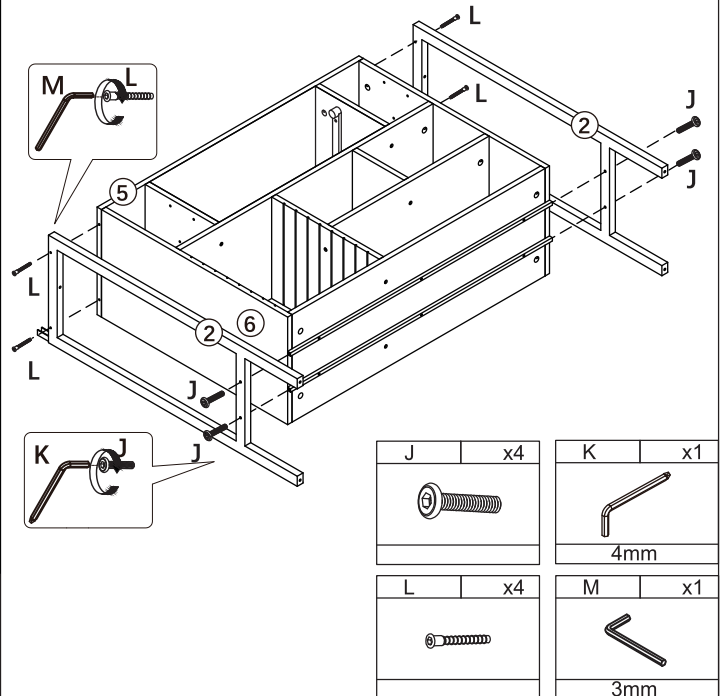

18 Rotate the adjustable foot Z x4 to the bottom of the Metal Legs Parts #2

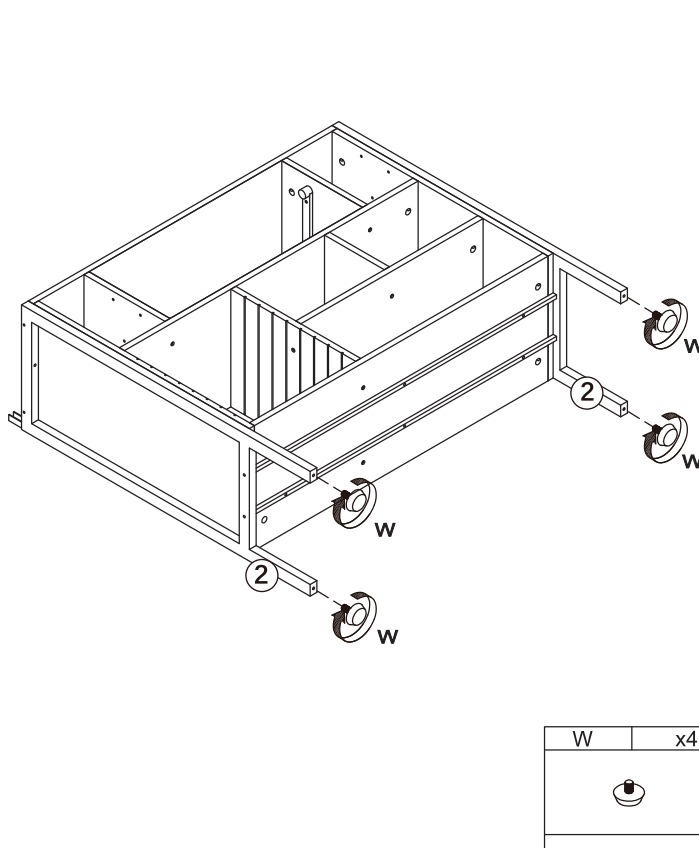

19 In case of unevenness with the ground after installation. Adjustable factory pre installed adjustable foot mats.

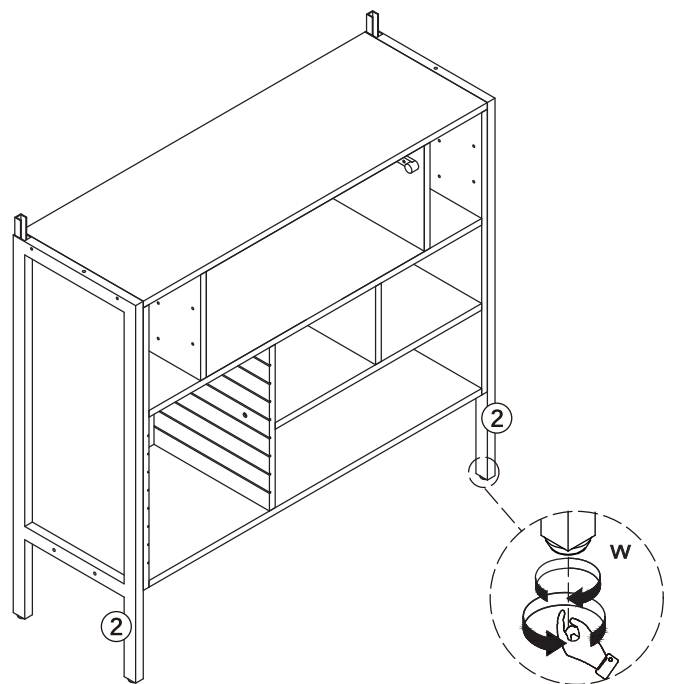

20 Raise the height of the door panel Part #10 , above the track, move into the cabinet.

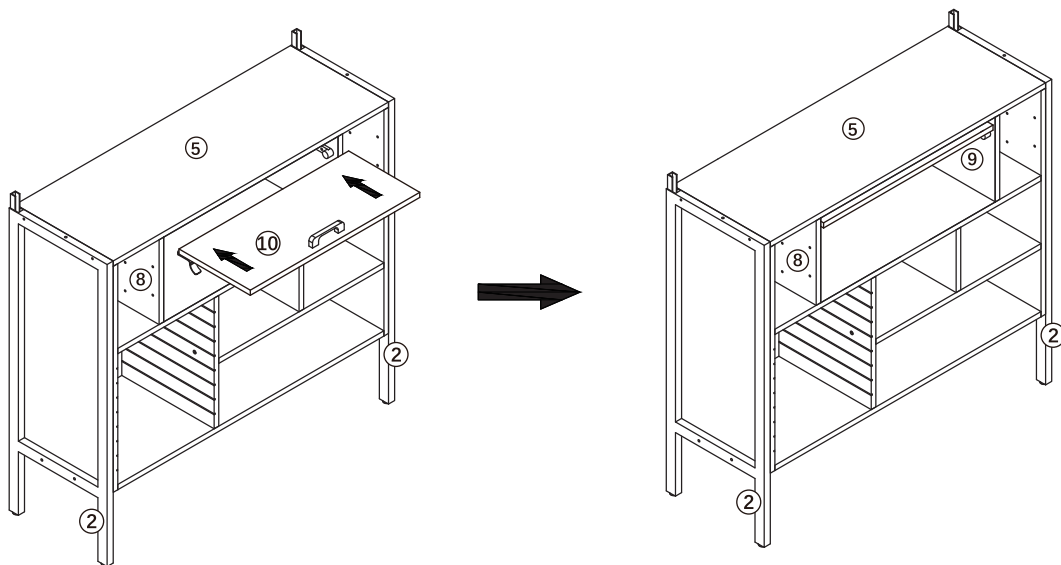

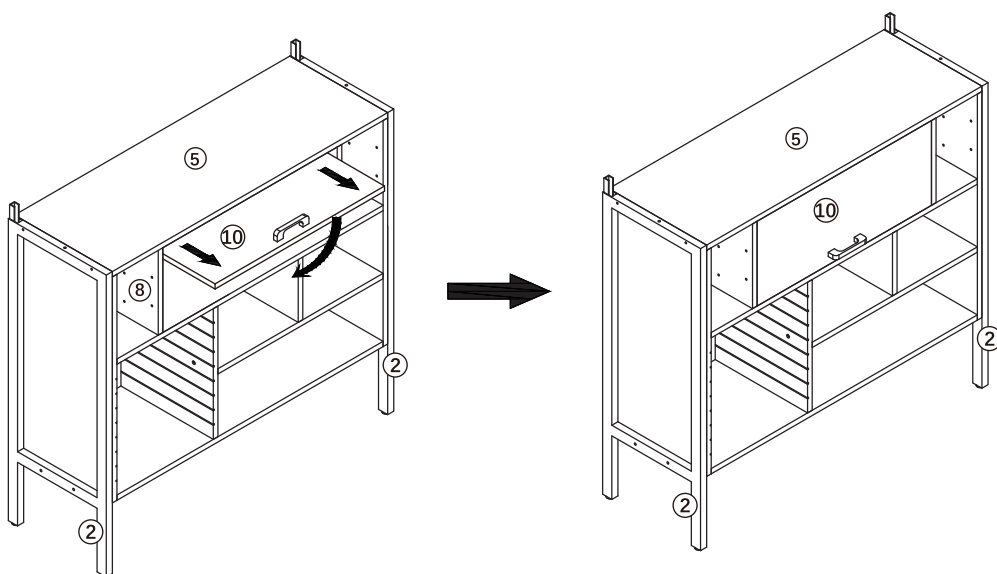

21 When you need to close the cabinet, pull out the door panel, then put it down and close it.



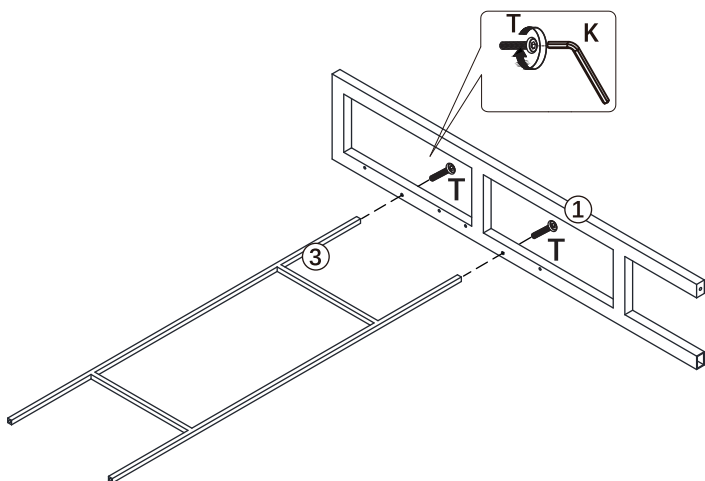

22 Connect Parts #1 & #3 as shown with Bolts T and Allen wrench K



T	x2	K	x1
			
		4mm	

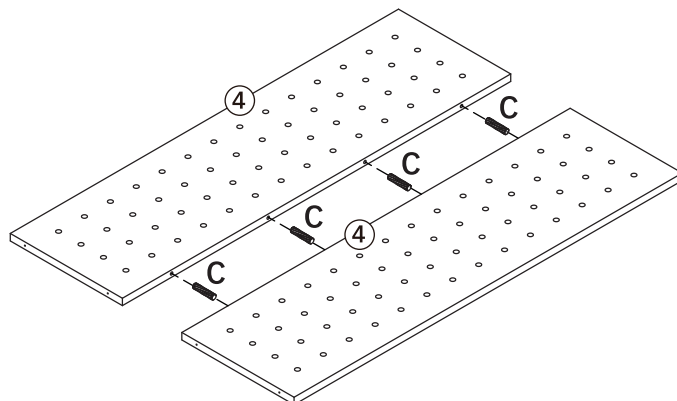

23 Connect two Parts #4 with Dowels C x4



C	x4
	

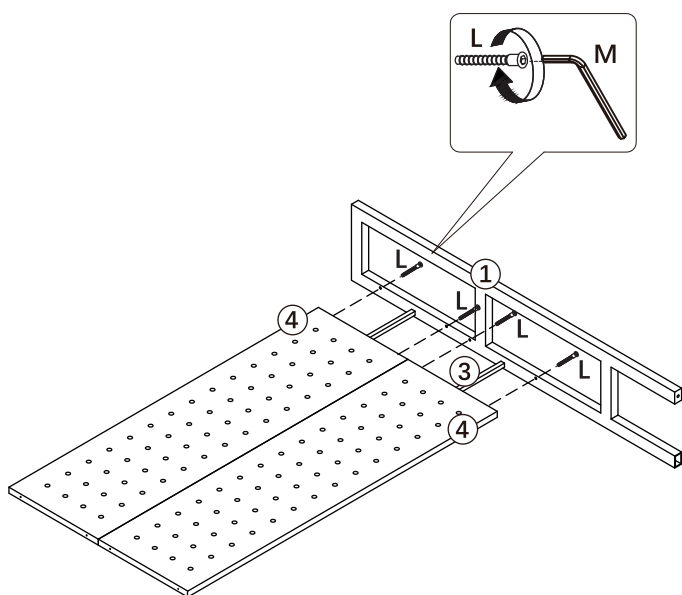



24 Attach Connected Parts #4 to Part #1 using Bolts L x4 . Tighten with Allen wrench M.

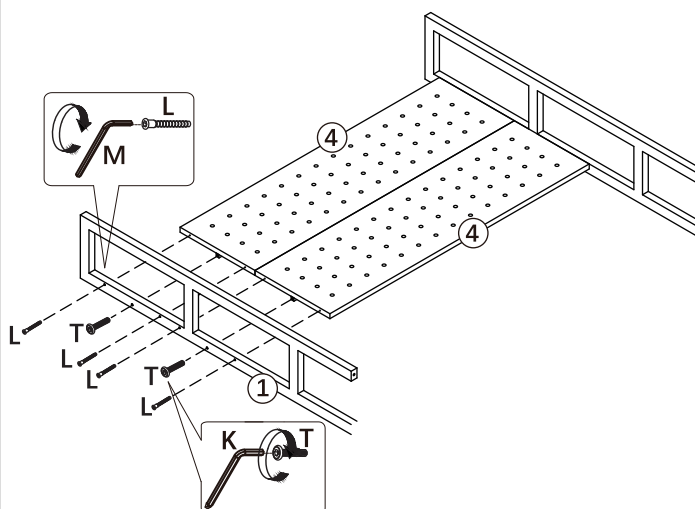

L	x4	M	x1
			
		3mm	

25 Attache other side Part # 1 to connected Parts #4 using Using Bolts L x4 and Bolts T x2. Use appropriate allen wrench.



T	x2	K	x1
			
		4mm	
L	x4	M	x1
			
		3mm	

26 Insert the top half of unit to bottom half as shown by sliding rear of parts #1 and #1 onto steel pipes.
Then secure as shown using bolts Y x2.

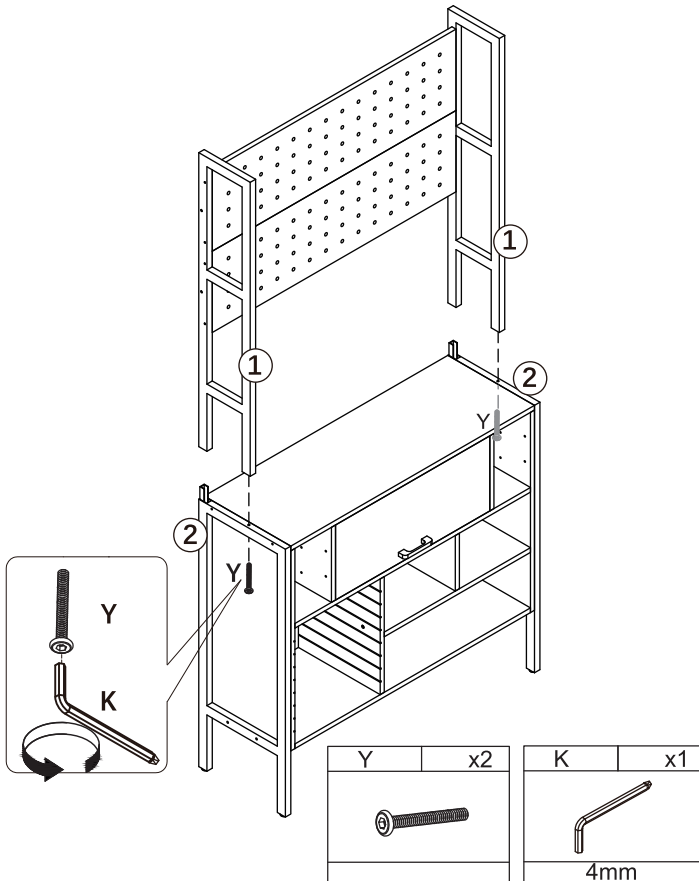

27 Further secure the top and bottom using bolts R x2 into parts #1 and #2

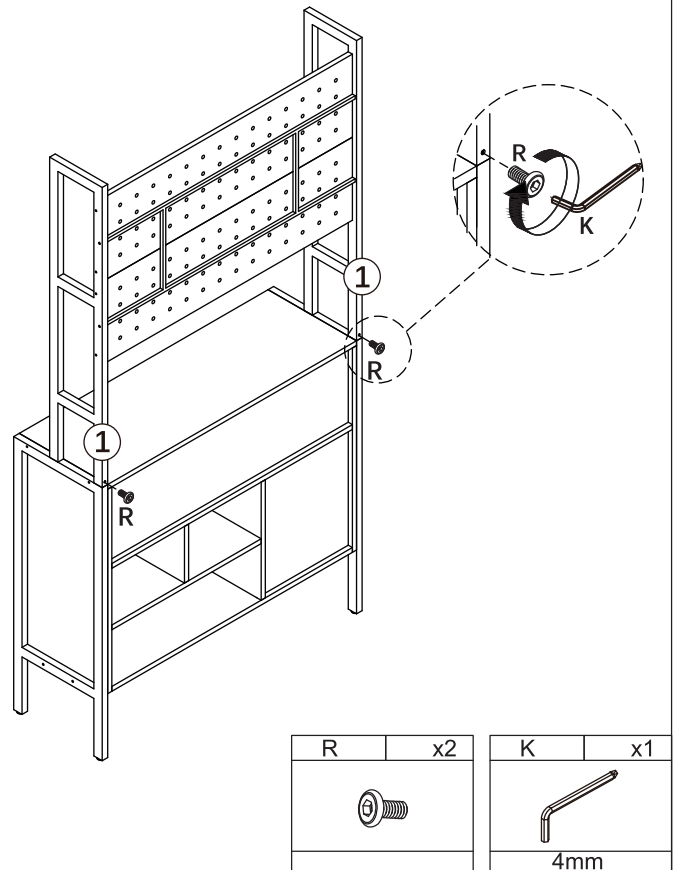

28 Insert Part O-2 into gap as shown and tighten with screw O-1

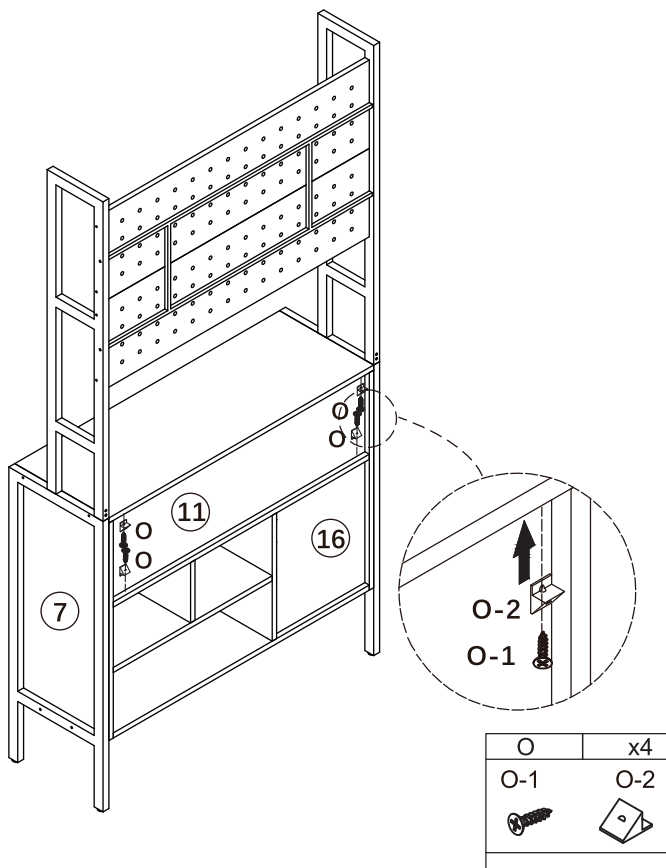

29 Insert shelf support pegs into holes (Part I) x16 and install shelves Part #21 x4

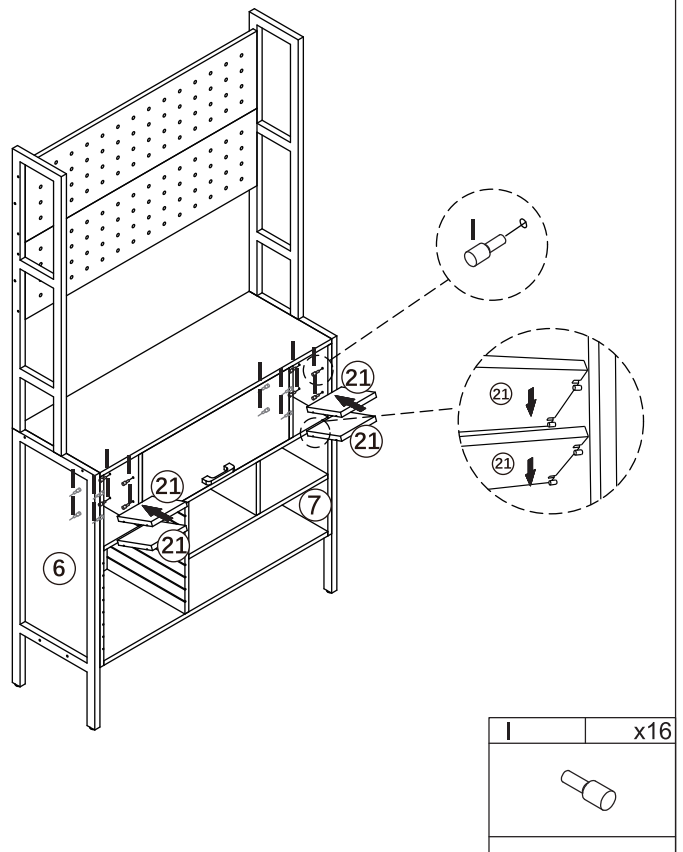

30 Slide Part #22 x8 into groove as shown.

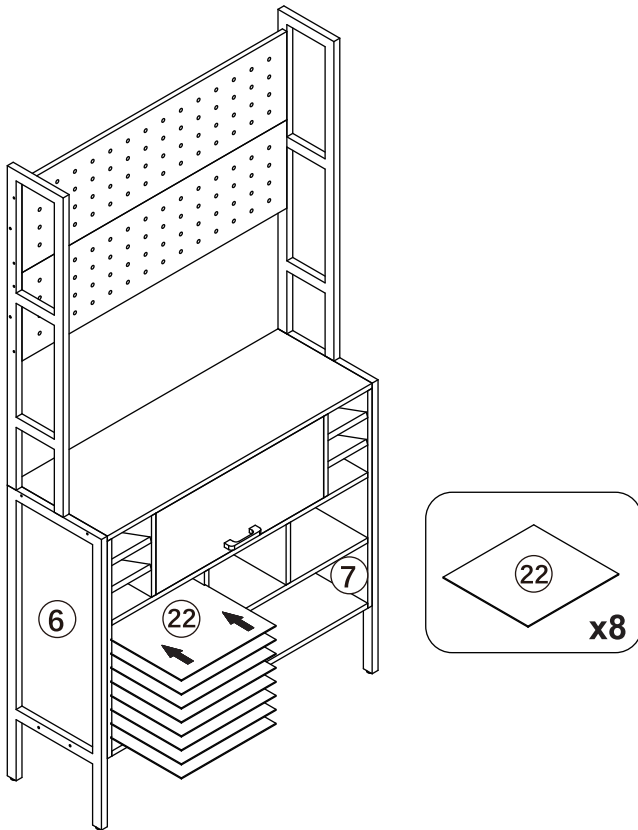

31 Assemble the Drawer units as shown using Parts #23 / #24. Attach handle (part X-2) using screws X-1. Assemble the partitions using Parts #26 x2 and #25 as shown.

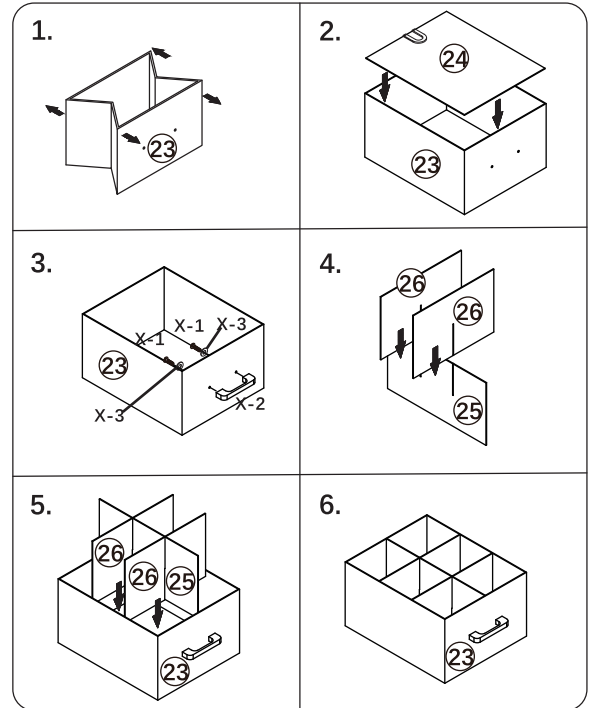

x2

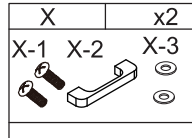

32 Assemble the larger drawer by repeating the above process using Parts #27 / #28. Attach handle (part X-2) using screws X-1. Assemble the partitions using Parts #29 x3 and #30 x2 as shown.

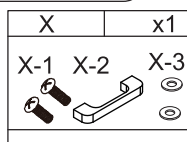
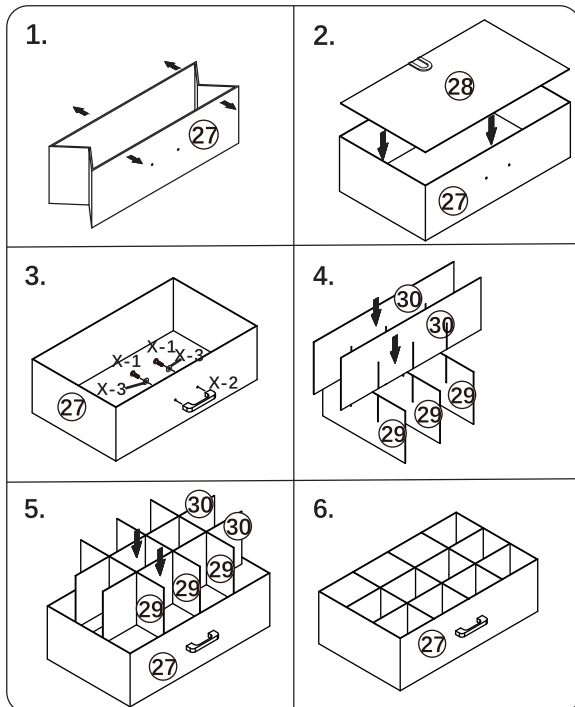

33 Slide 3 drawers into the Cabinet.

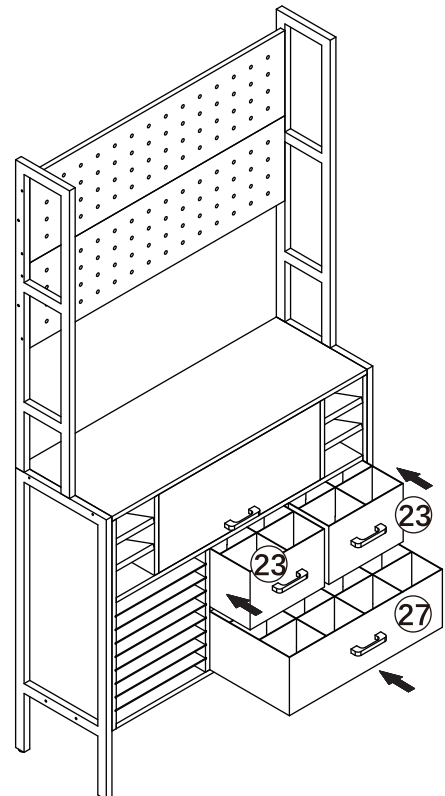

Total number of accessories available

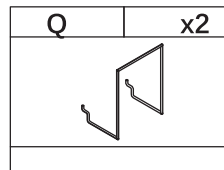
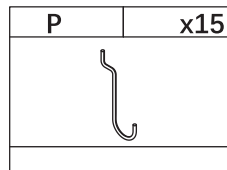
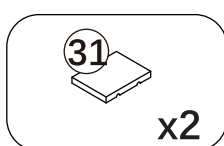
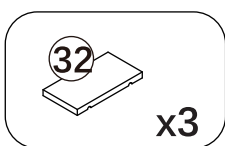
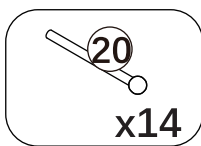

Arrange pegs and shelves to desired locations

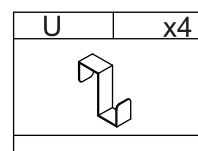
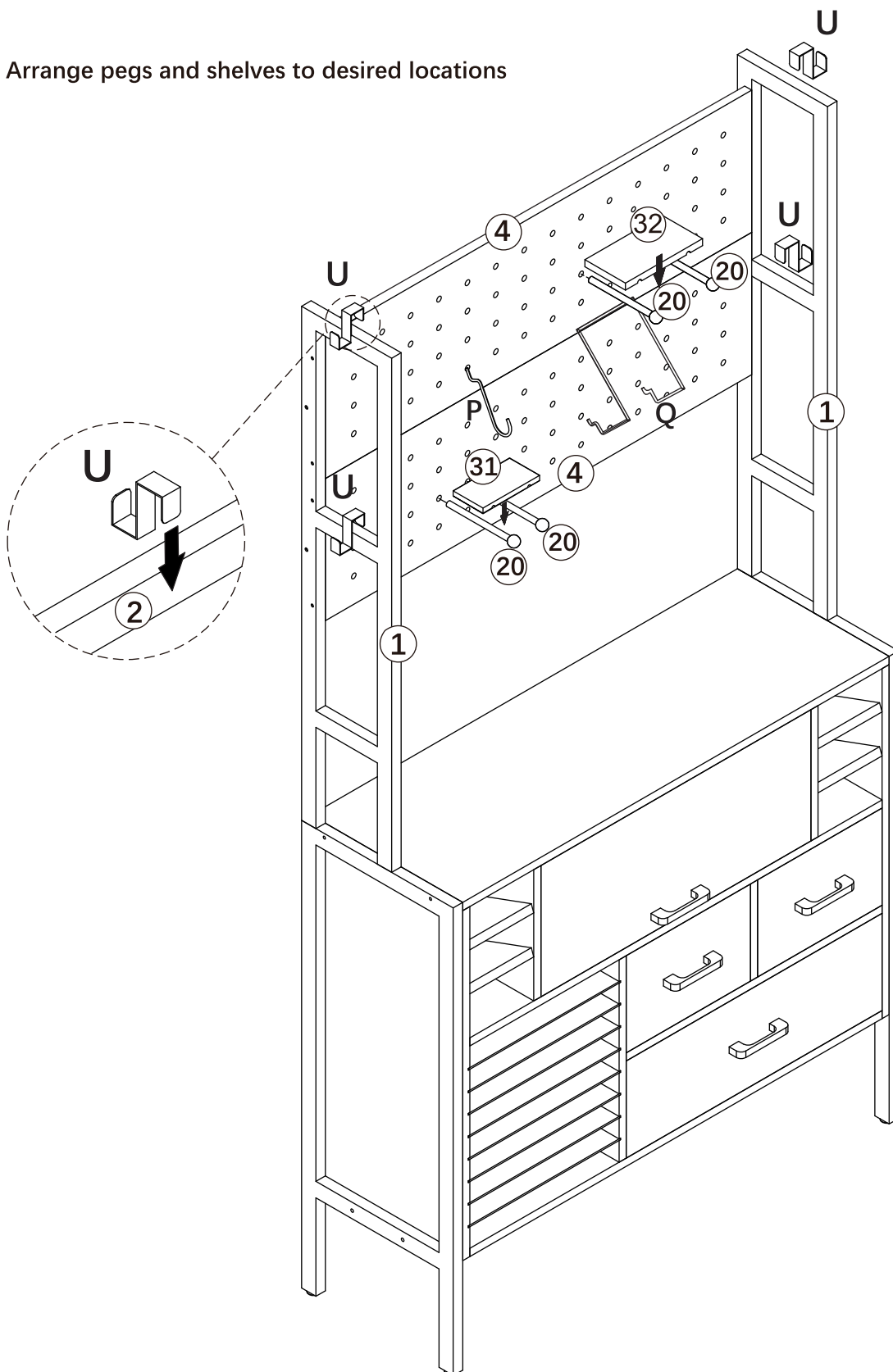

35

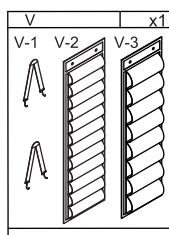
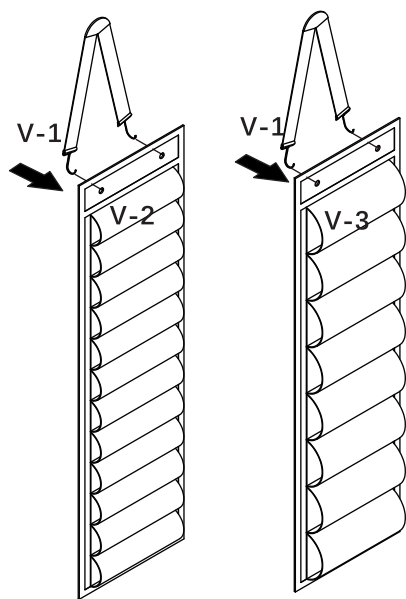

36

Use Part U hangers to hang vinyl roll holders as shown.

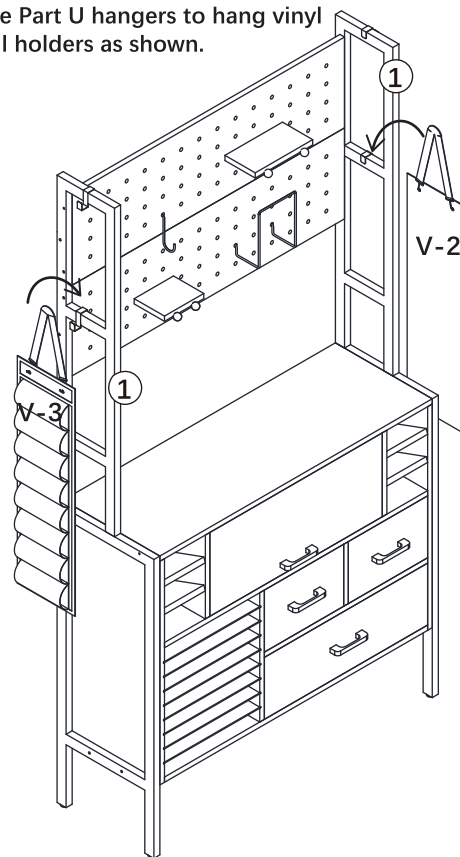

37

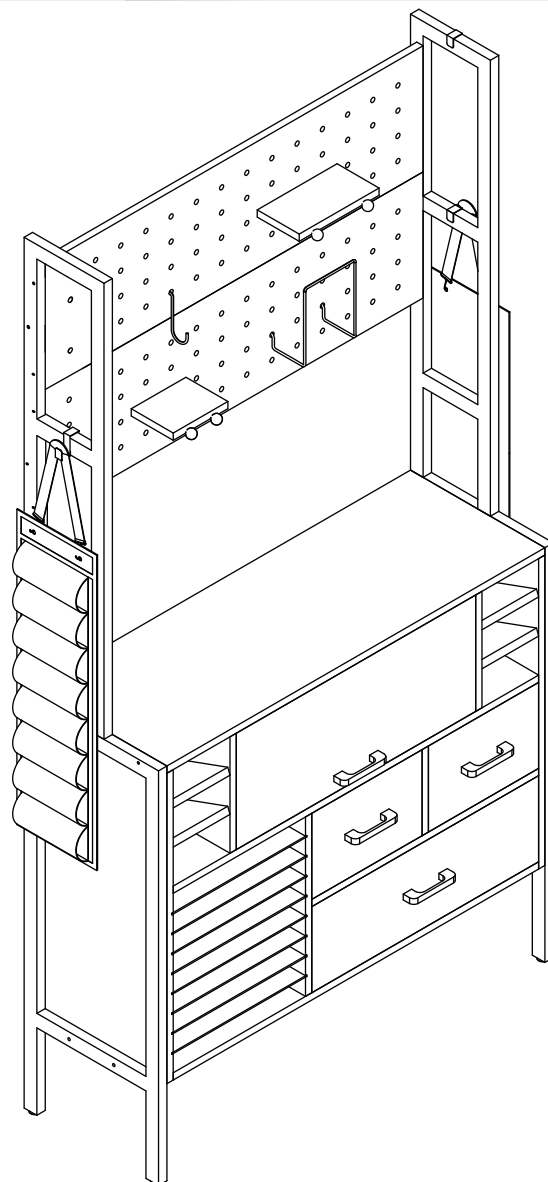

Punch holes in the wall and install anti-rewind tape according to the picture steps.
Enjoy your new Organizer!

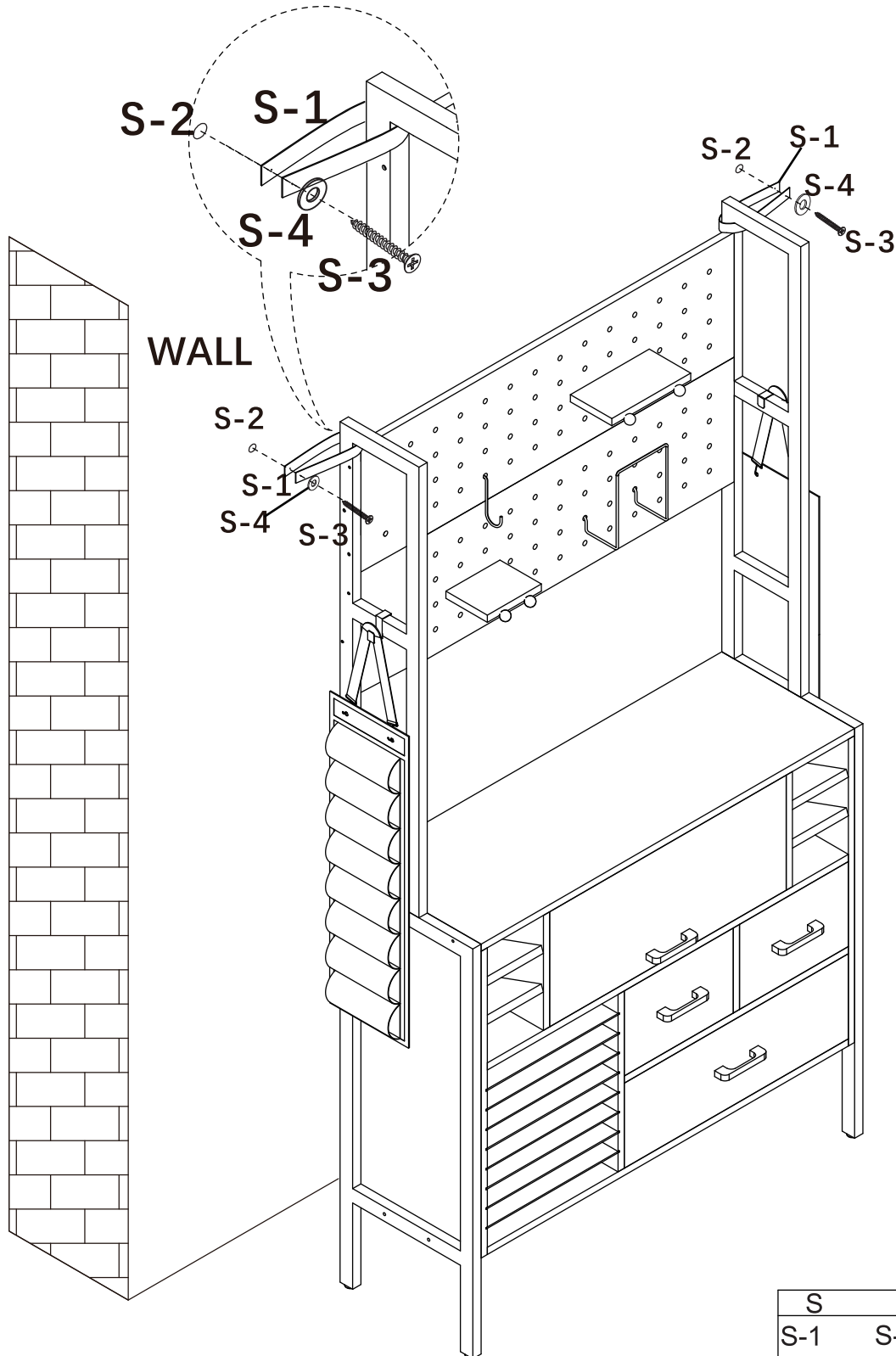
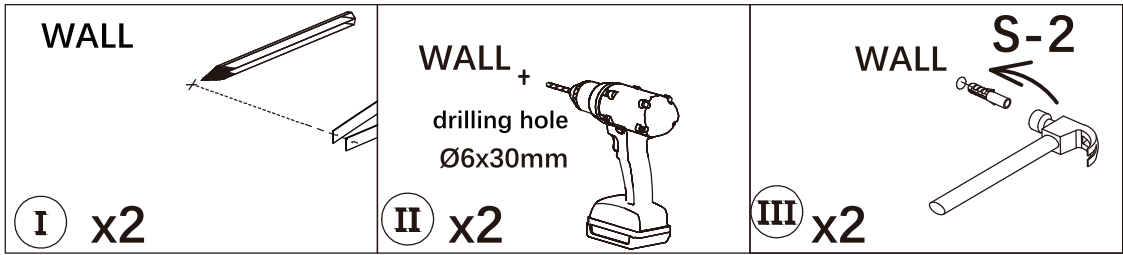

S			x2
S-1	S-2	S-3	S-4