

5-Piece Round Sectional Set

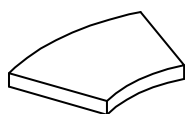

Seat Cushion
X4

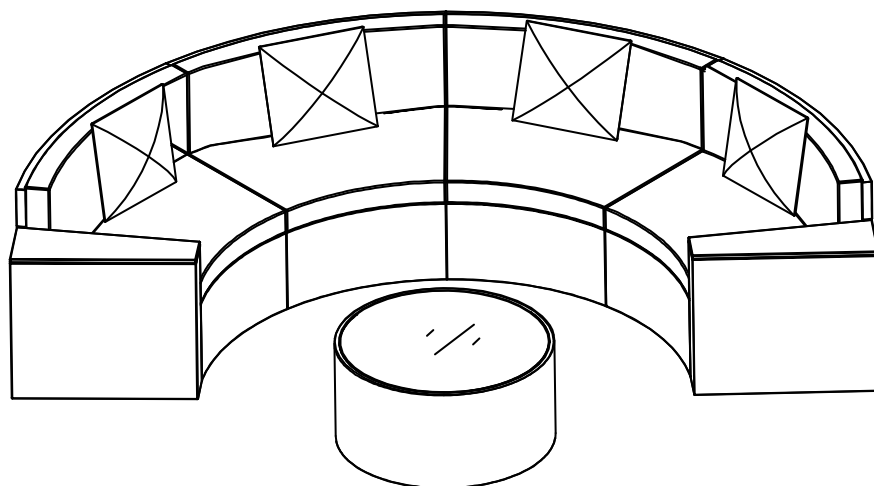
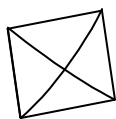

Pillow X2

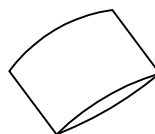

Assembly Bag X1

CARTON 1/4

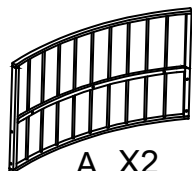

A X2

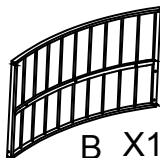

B X1



C X1

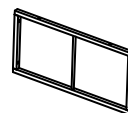

G X2

CARTON 2/4

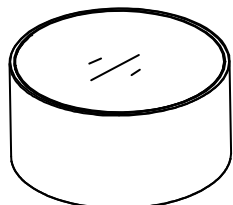

X1



Back Cushion X4

CARTON 3/4



D X2



F X1

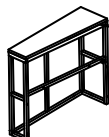

H X1

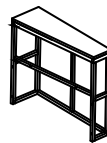

I X1

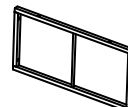

G X4



E X1



J X2



U X1

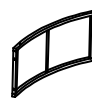



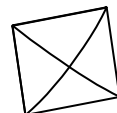

S X1

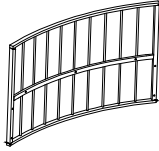
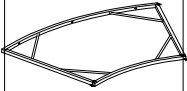
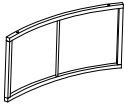
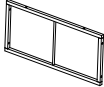

Pillow X2

CARTON 4/4

Middle Seat (Do this twice)

Item No.	Reference Image	Description	Qty.
A		Seat Back	1
D		Seat Base	1
J		Seat Front Panel	1
G		Side Panel	2
L		M6 x 36 Head Cap Screw	14
P		Washer	14
R		Allen Key	1
T		Leveler	4

Tips: Do not tighten all screws fully before the item is well assembled.

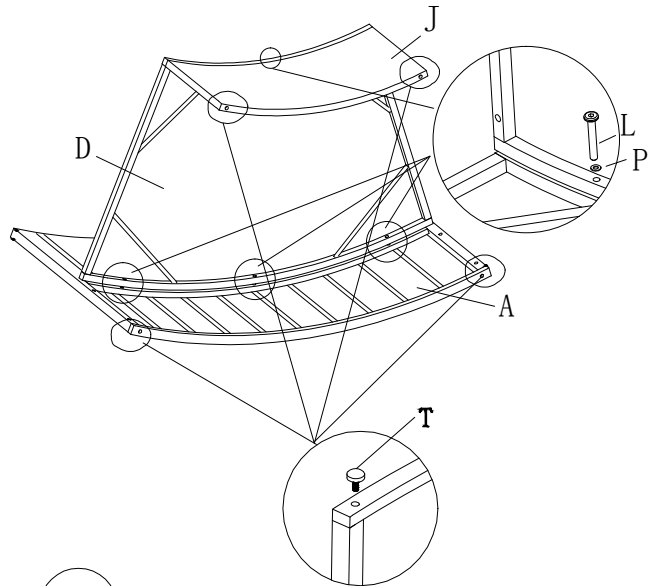

1

As drawing details shown above:
Fix the levelers (T) to the seat back (A) and seat front panel (J). this in four places.

Fix the seat back (A) to the seat base (D) by securing head cap screws (L) and washers (P). Do this in three places.

Fix the seat front panel (J) to the seat base (D) by securing head cap screws (L) and washers (P). Do this in one place.





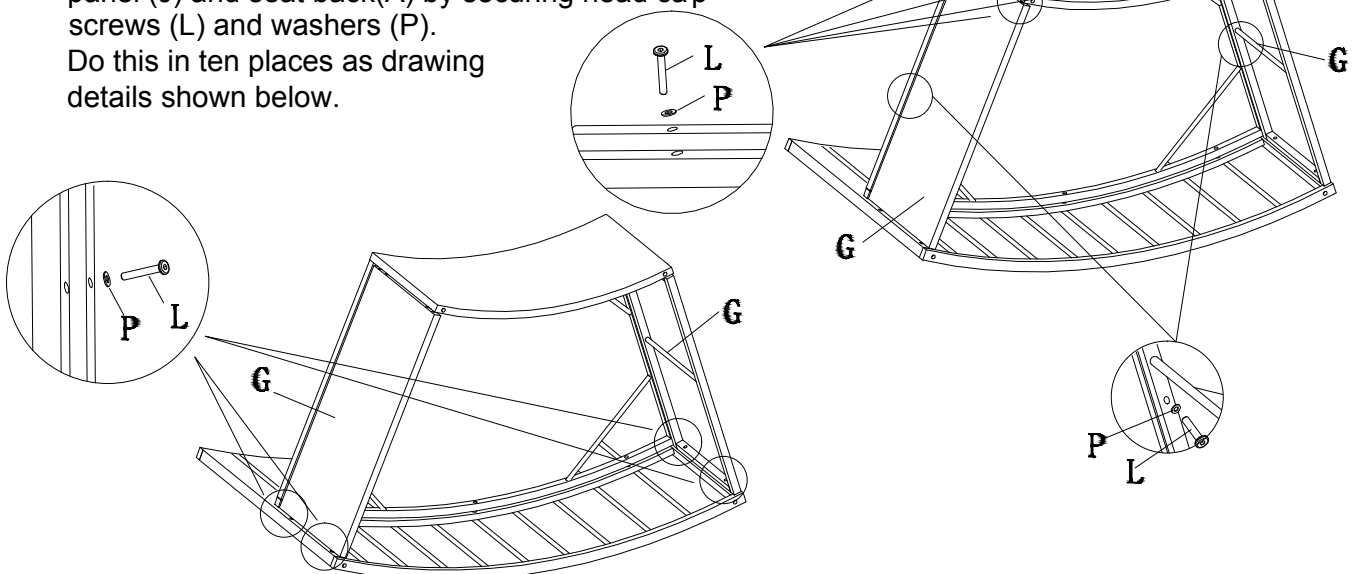

2

Fix the two side panels (G) to the seat front panel (J) and seat back (A) by securing head cap screws (L) and washers (P).

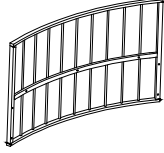
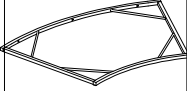
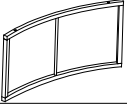
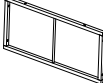
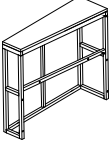
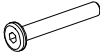
Do this in ten places as drawing details shown below.



Right End Seat

Item No.	Reference Image	Description	Qty.
B		Right Seat Back	1
E		Right Seat Base	1
S		Seat Front Panel	1
G		Side Panel	1
H		Right Arm Rest	1
L		M6 x 36 Head Cap Screw	14
M		M6 x 20 Head Cap Screw	2
N		Bracket	1
P		Washer	16
R		Allen Key	1
T		Leveler	6

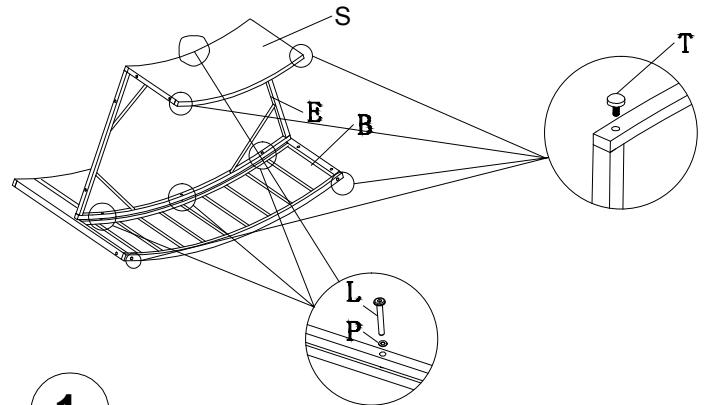

1

As drawing details shown above:

Fix the levelers (T) to the right seat back (B) and seat front panel (S). Do this in four places.

Fix the right seat back (B) to the right seat base (E) by securing head cap screws (L) and washers (P). Do this in three places.

Fix the seat front panel (S) to the seat base (E) by securing head cap screws (L) and washers (P). Do this in one place.

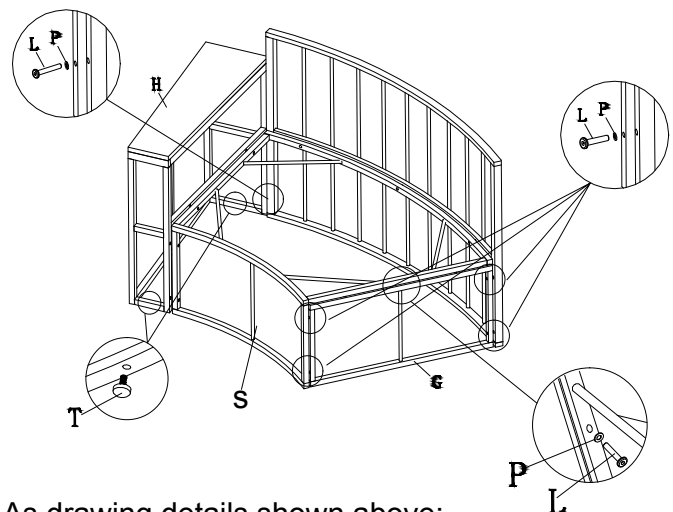

2

As drawing details shown above:

Fix the levelers (T) to the right seat back (B). Do this in two places.

Fix the side panel (G) to the right-hand side of the right seat front panel (S) and seat back (B) by securing head cap screws (L) and washers (P). Do this in five places.

Fix the right arm rest (H) to the bottom right side of the right seat back (B) by securing head cap screw (L) and washer (P).

Tips: Do not tighten all screws fully before the item is well assembled.

Right End Seat

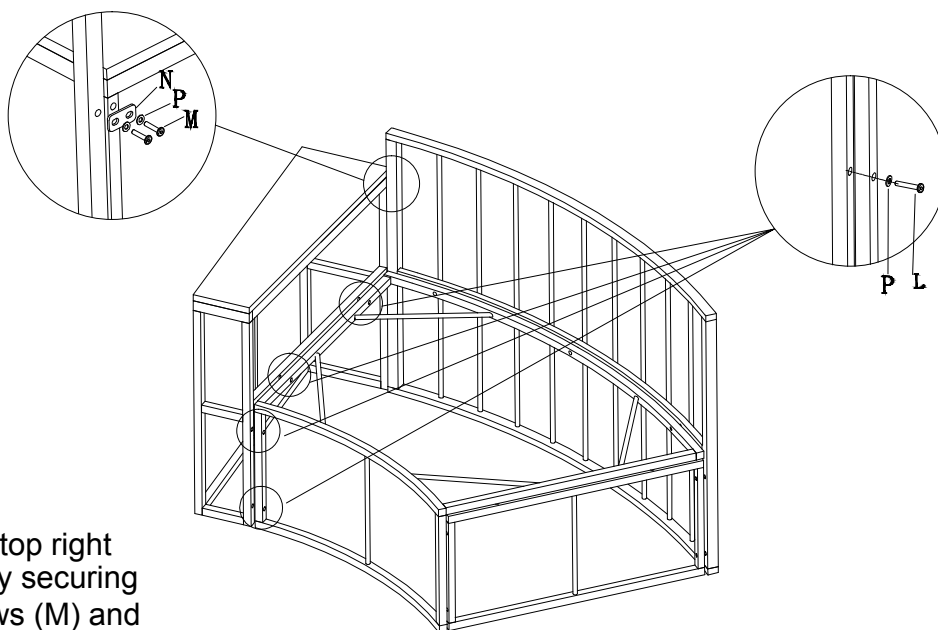

3







Fix the right arm rest (H) to the top right side of the right seat back (B) by securing bracket (N) with head cap screws (M) and washers (P). Do this in one place.

Fix the right arm rest (H) to the right side of the right seat base (E) and (S) by threading head cap screws (L) and washers (P) . Do this in four places.

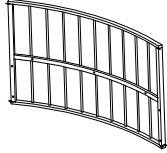
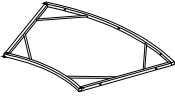
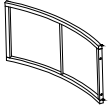
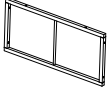
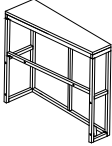
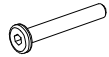
Tips: Do not tighten all screws fully before the item is well assembled.

Please use a screwdriver kit instead of an electric screwdriver to turn the screws.

Left End Seat

Item No.	Reference Image	Description	Qty.
C		Left Seat Back	1
F		Left Seat Base	1
U		Seat Front Panel	1
G		Side Panel	1
I		Left Arm Rest	1
L		M6 x 36 Head Cap Screw	14
M		M6 x 20 Head Cap Screw	2
N		Bracket	1
P		Washer	16
R		Allen Key	1
T		Leveler	6

Tips: Do not tighten all screws fully until the item is well assembled.

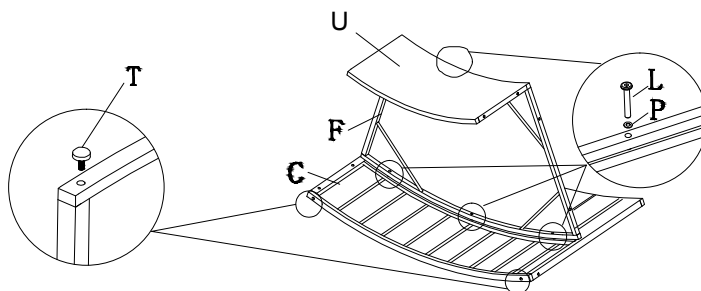

1

As drawing details shown above:

Fix the levelers (T) to the left seat back (C). Do this in two places.

Fix the left seat back (C) to the left seat base (F) by securing head cap screws (L) and washers (P). Do this in three places.

Fix the seat front panel (U) to the seat base (F) by securing head cap screws (L) and washers (P). Do this in two places.

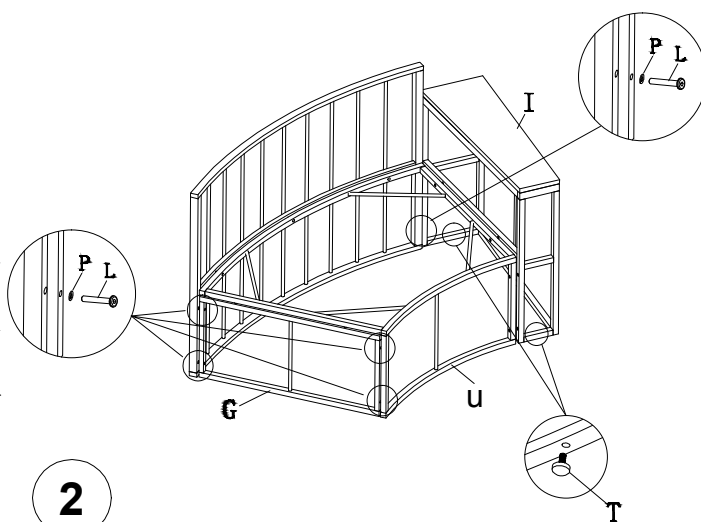

2

As drawing details shown above: fix the side panel (G) to the left-hand side of the left seat front panel (U) and seat back (C)

Do this in four places.

Attach the left arm rest (I) to the bottom left side of the left seat back (C) by securing head cap screw (L) and washer (P).

Left End Seat

3

Fix the left arm rest (I) to the left side of the left seat base (F) and (U) by threading head cap screws (K) with washers (P) through the furniture and securing into place with washers (P). Tighten into place with Allen key (R). Do this in four places.

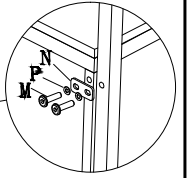
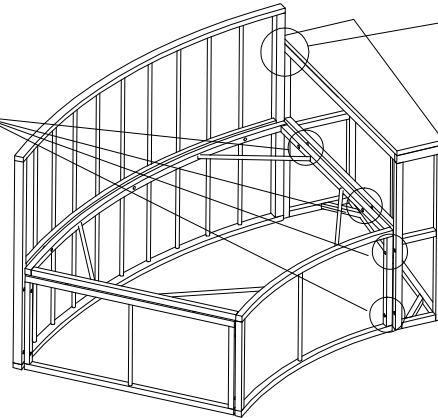
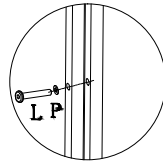

Fix the left arm rest (I) to the top left side of the left seat back (C) by securing bracket (N) with head cap screws (M) and washers (P).

Tips: Do not tighten all screws fully until the item is well assembled.

4

Clip every two adjacent parts with two clips (J) on the bottom to prevent parts from sliding as drawing details below:

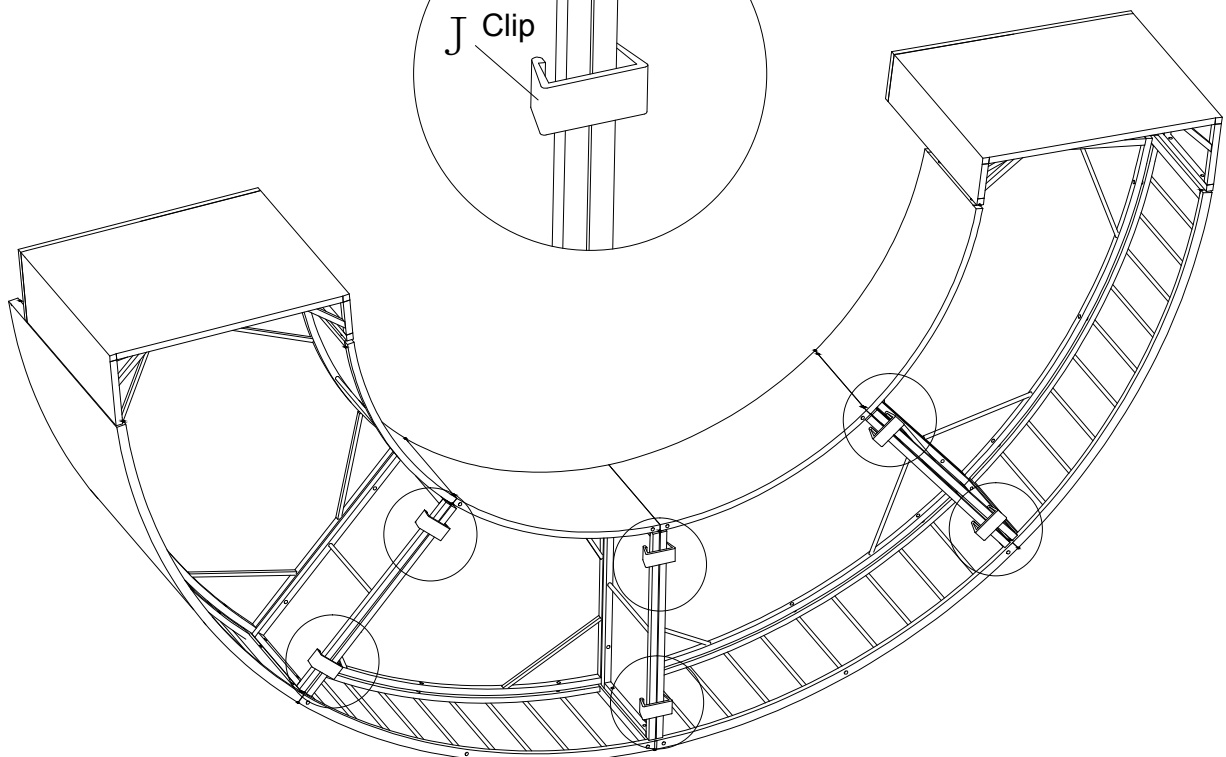
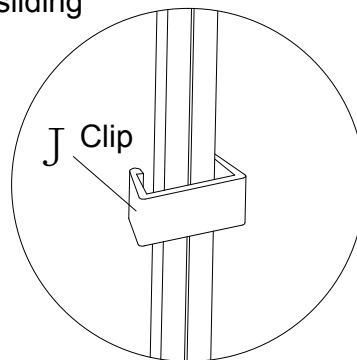



CAUTION

In order to the Beauty of sofa appearance, the back cover is then designed to be a bit tight which may cause some difficulties in installation. To prevent the cover being ripped, you are recommend to put the cushion onto the seatback from both sides slowly while assembling.

