

ASSEMBLY INSTRUCTION

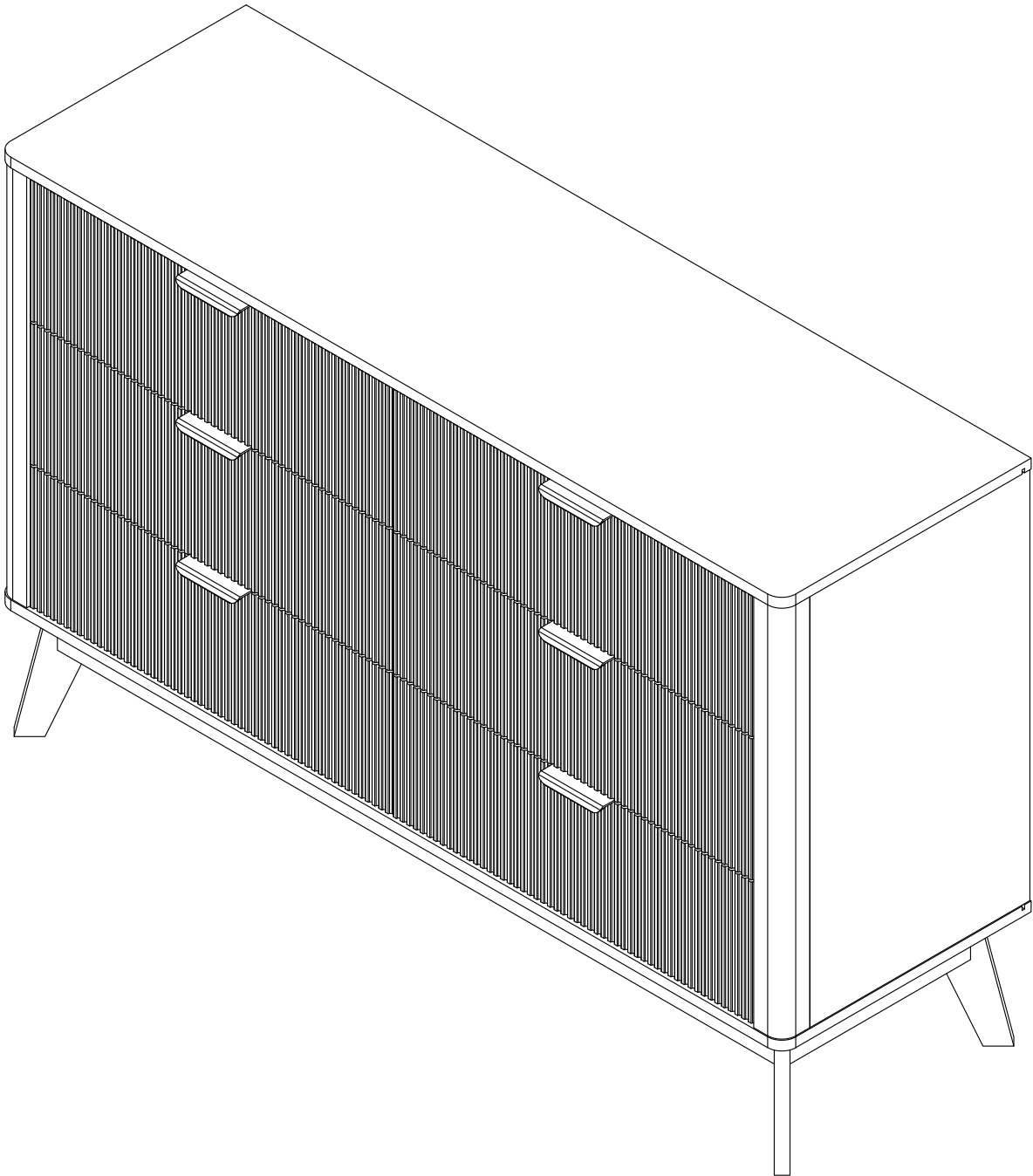

Guarantee



Do not return

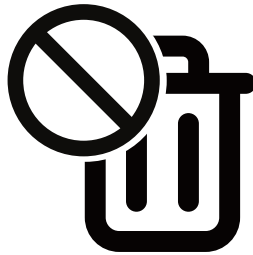

Do not throw

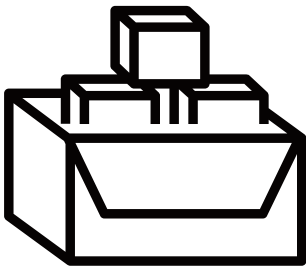
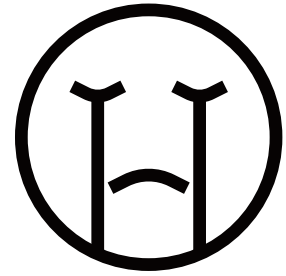

New product



Refund



Order ID	
Buyer Name	
Buyer Contact	
Buyer Address	
Buyer Request	<input type="checkbox"/> Refund <input type="checkbox"/> New One without Return <input type="checkbox"/> Repair <input type="checkbox"/> Replacement <input type="checkbox"/> Return
In-Policy Warranty	
Product quality problem: Broken or scratched Pieces/ Missing Pieces/ Unable to assemble Logistics problem: Delayed delivery/ Wrong address delivery/ Undelivered	
Not In Warranty Policy	
Don't want/need anymore The dimensions/description/color are not as expected	
No matter what problem you encounter, it is recommended to try our after-sales service first. Sending your question to the service staff in the form of a picture or video will help the service staff better understand your question so that they can better help you. Returning a product is a very difficult thing to do, before you decide to return it, please contact the service staff, a refund and a brand new product will be better options.	

Note

In order to enhance product durability, extend its lifespan, improve your user experience, and save time, we provide the following suggestions to assist you with the assembly process:

1. Please follow the installation steps to avoid unnecessary effort or assembly failures.
2. We suggest checking all screws every six months to ensure they are secure. If any screws are loose or if there are signs of rust, severe deformation, or wear, please tighten or replace the components promptly to maintain product performance and extend its lifespan.



Person Recommended

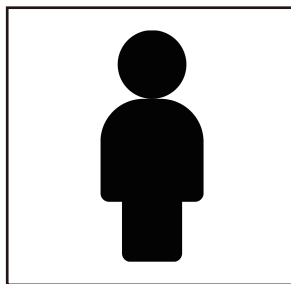
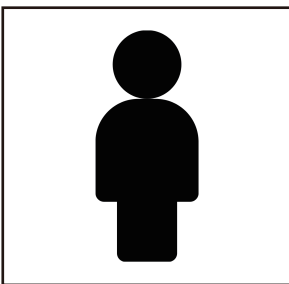

Tools Recommended

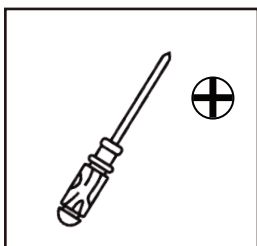

Phillips screwdriver

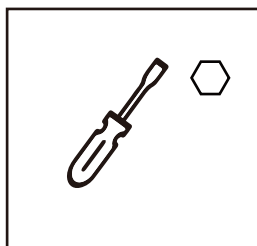

Hex bit socket screwdriver

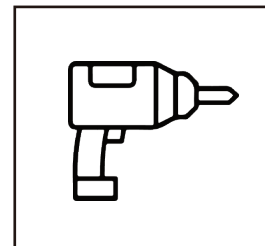

Electric drill

PARTS

1

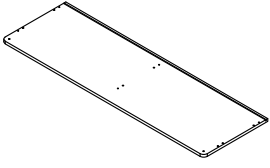

1

PC

2

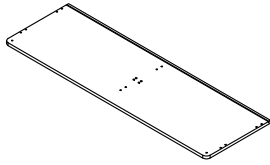

1

PC

3

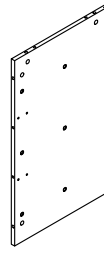

1

PC

4

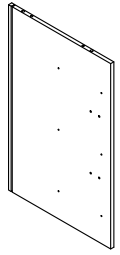

1

PC

5

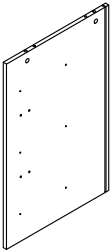

1

PC

6



1

PC

7



1

PC

8

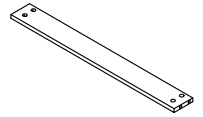

2

PCS

9

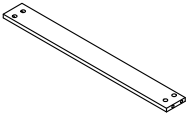

2

PCS

10

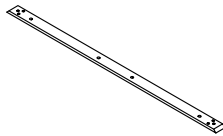

2

PCS

11

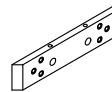

2

PCS

12



4

PCS

13



1

PC

14

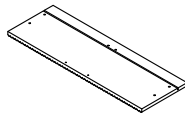

3

PCS

15

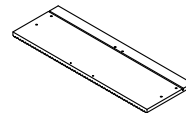

3

PCS

16

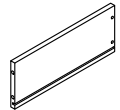

6

PCS

PARTS

17

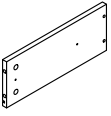

6

PCS

18

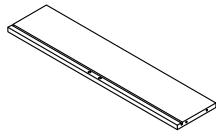

6

PCS

19

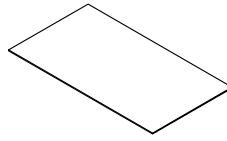

6

PCS

20

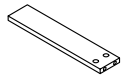

6

PCS

21

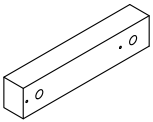

6

PCS

22

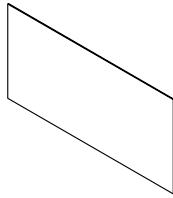

4

PCS

PARTS

A



62 PCS

B



Ø12

62 PCS

C



Ø6×30

22 PCS

D



M3.5×12

48 PCS

E

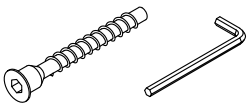

M5×40

44 PCS

F

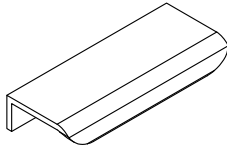

6 PCS

G

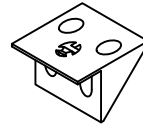

8 PCS

H

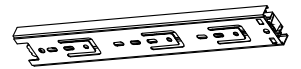

12 PCS

I



2 PCS

J

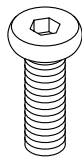

M6×25

16 PCS

K

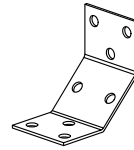

4 PCS

L

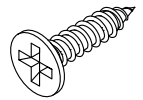

M3.5×14

22 PCS

M

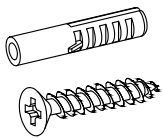

2 PCS

N

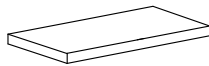

4 PCS

O

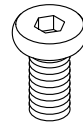

M6×10

32 PCS

P

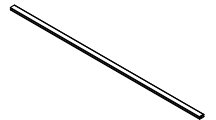

2 PCS

Q

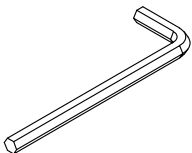

1 PC

R



1 PC

S



12 PCS

T



Ø15

12 PCS

PARTS

U



1

PC

V

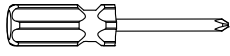

1

PC

Way of installing slide rail

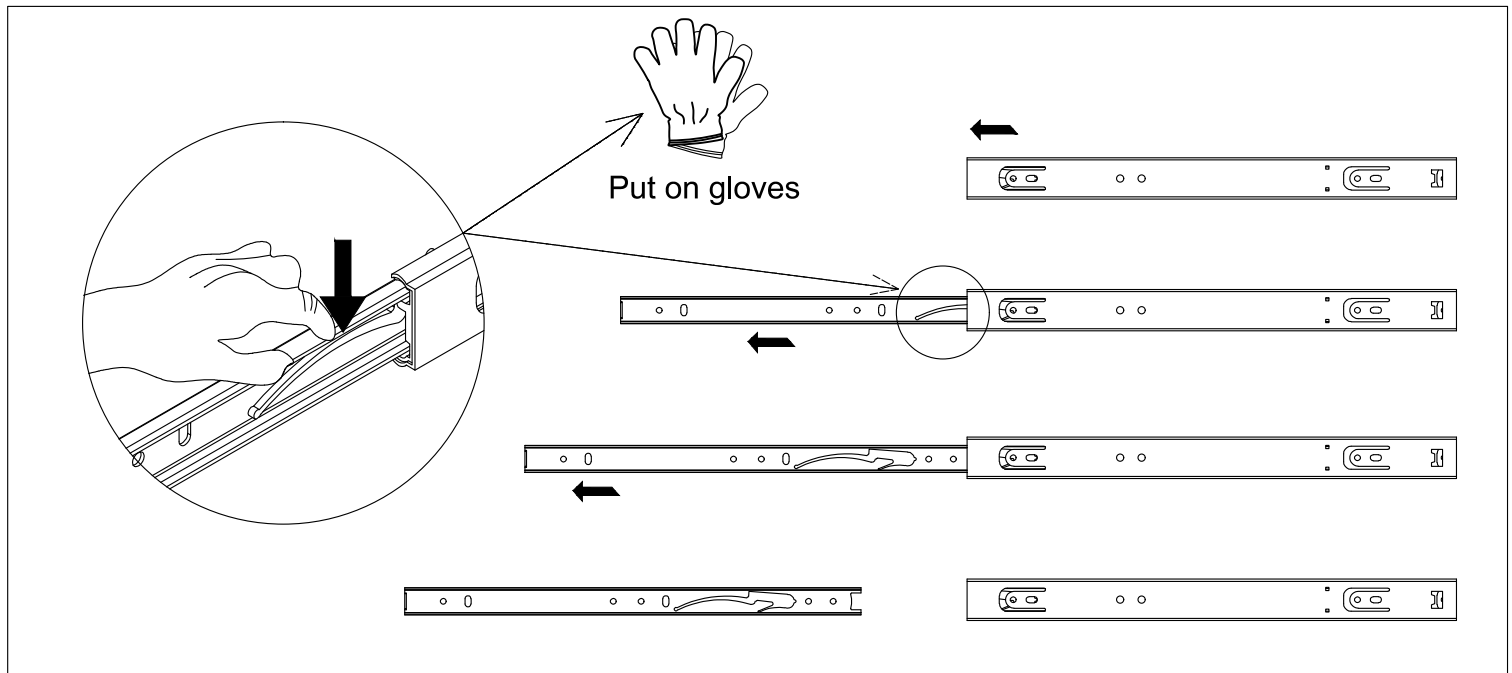

Step 1

Pull out internal rail

Step 2

Press the plastic clasp according to the diagram and keep pressing

Step 3

Keep pressing plastic clasp and slowly pull out



Step 4

Until the inner slide is fully pulled out

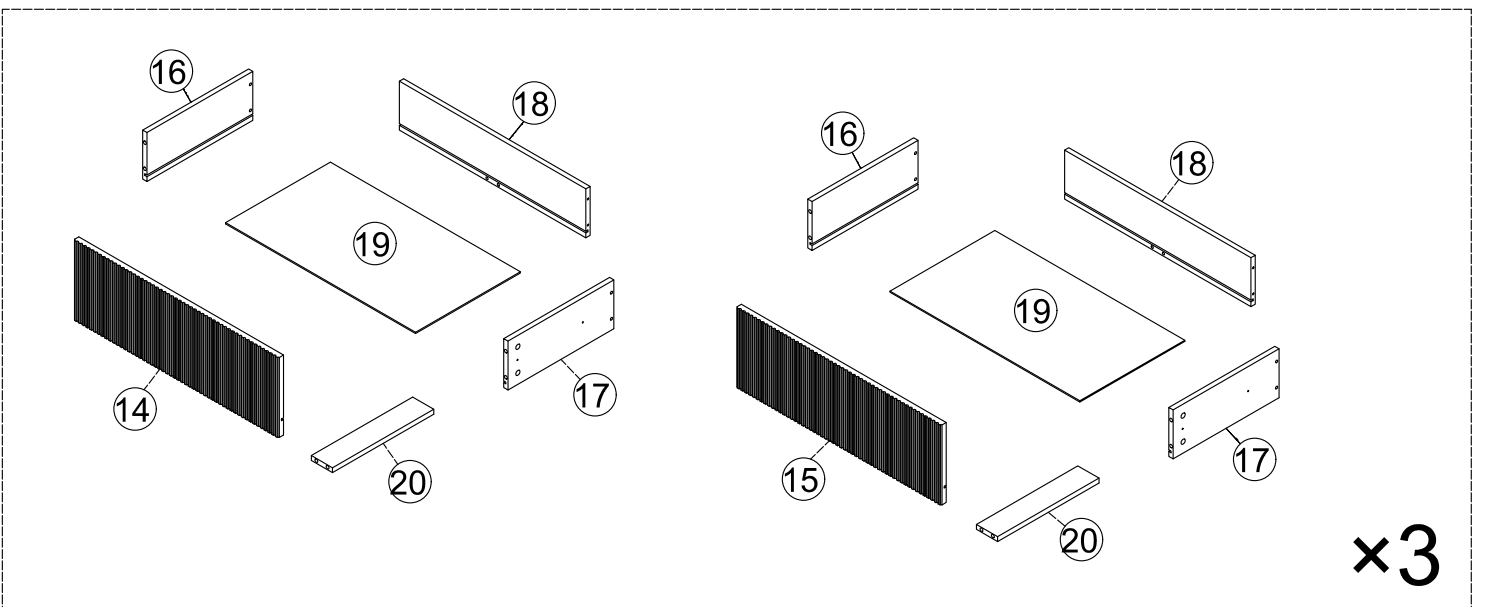
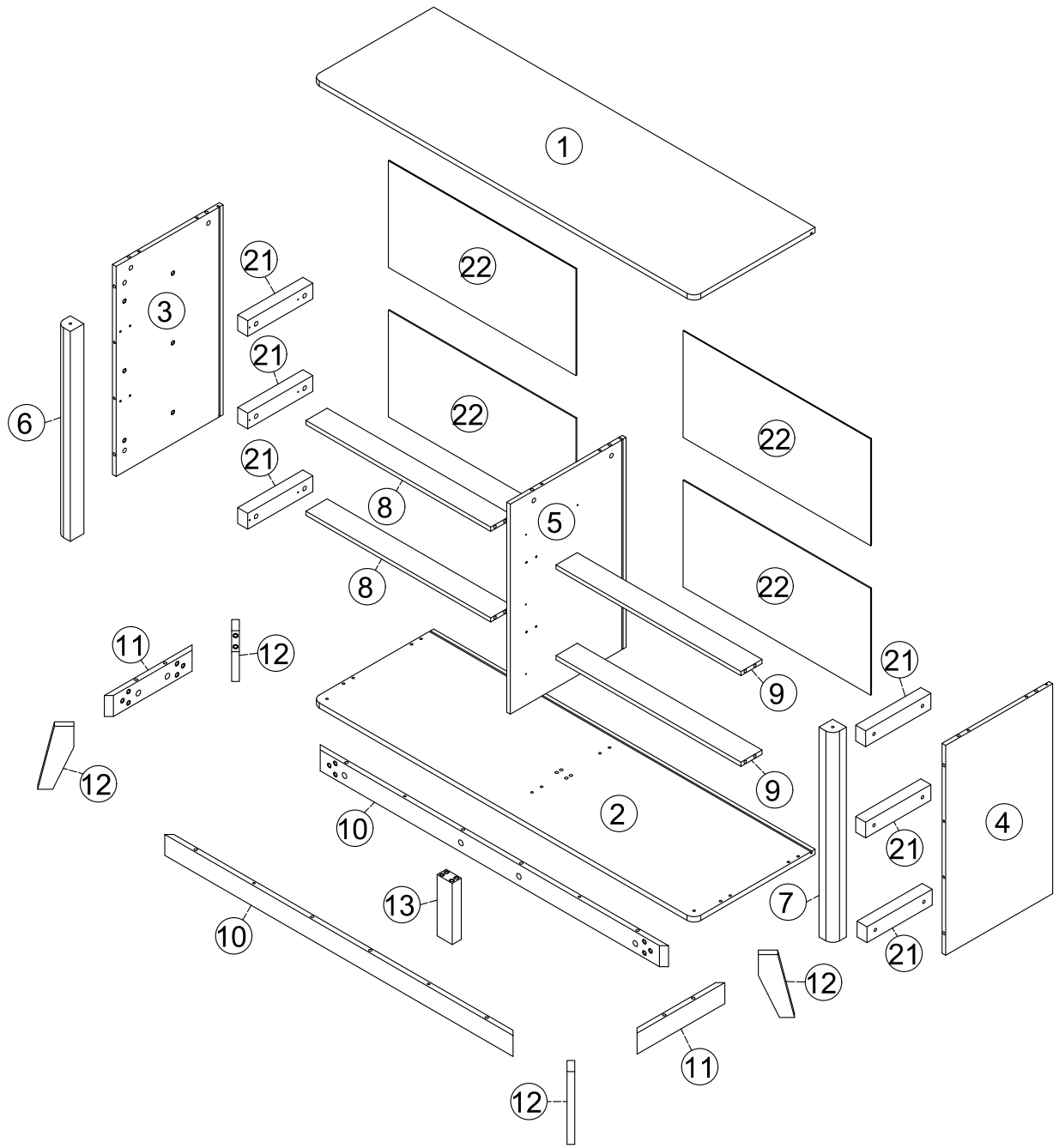
PARTS



×3

	D×12		H×6
---	------	---	-----

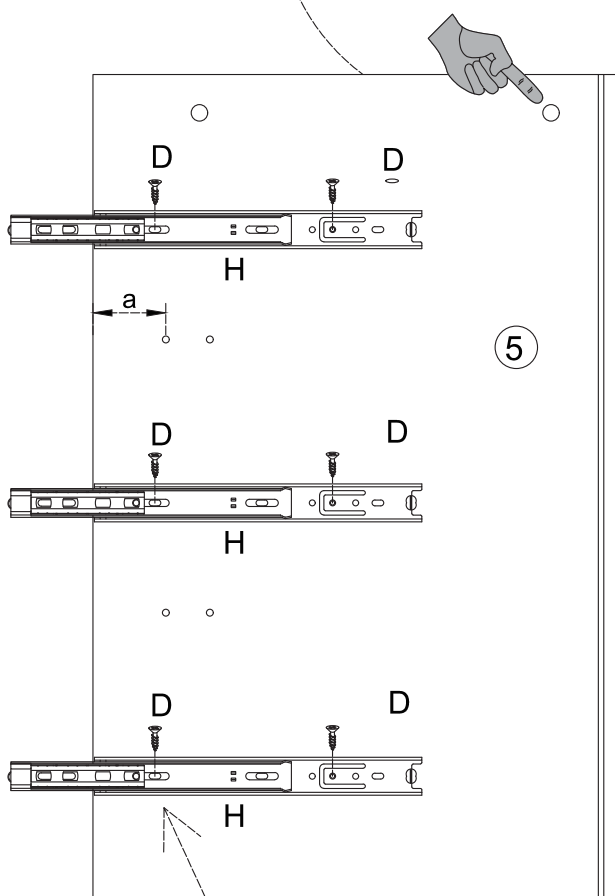
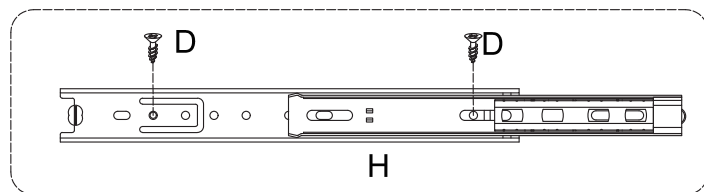
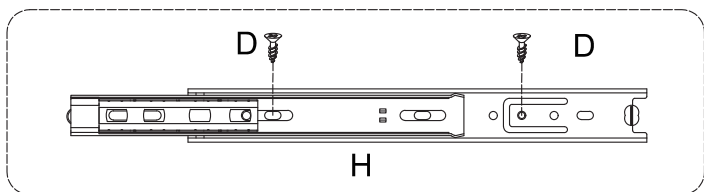

Please install this small hole first, and then install the third one from the right side.

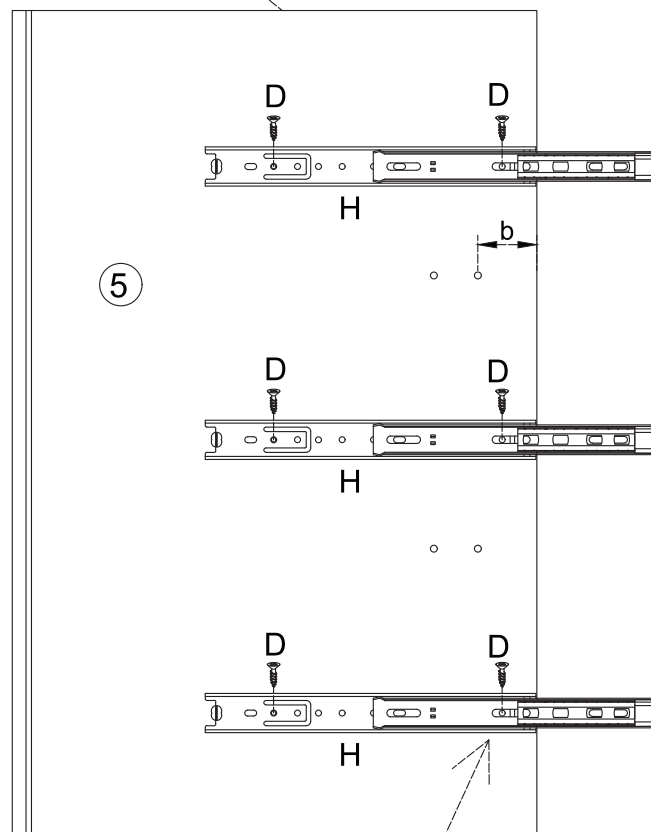

Please install this small hole first, and then install the second hole from the left side.

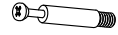

$$a > b$$

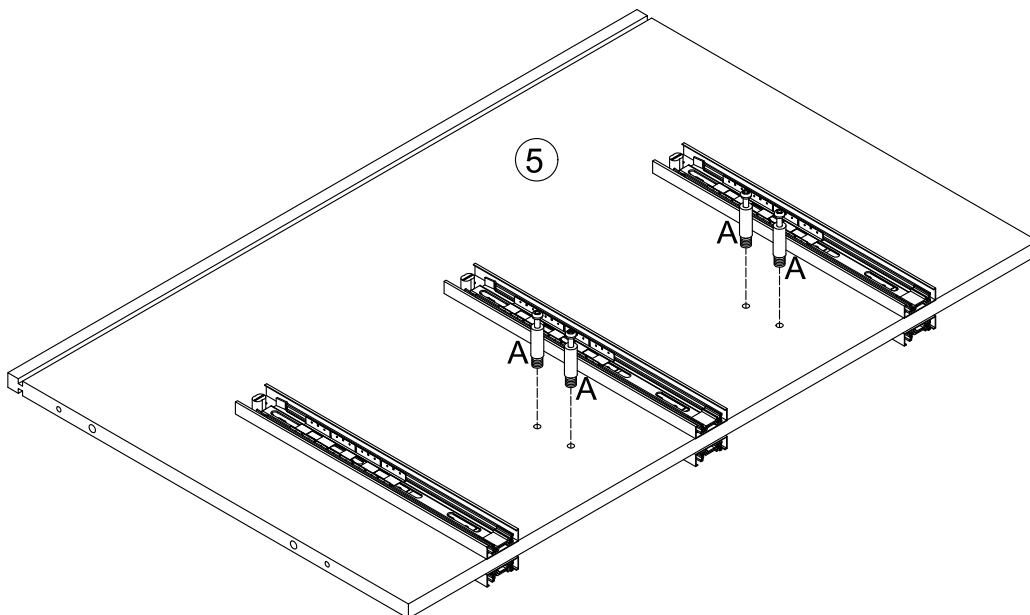
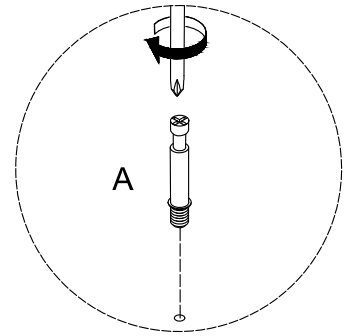
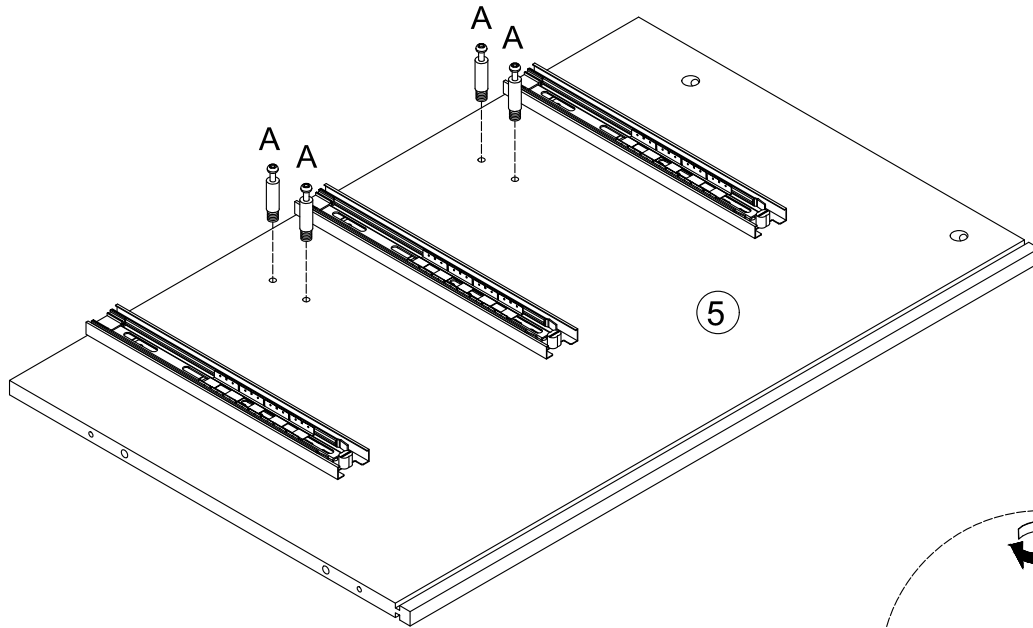

A×8

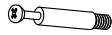

step3/step21

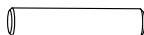

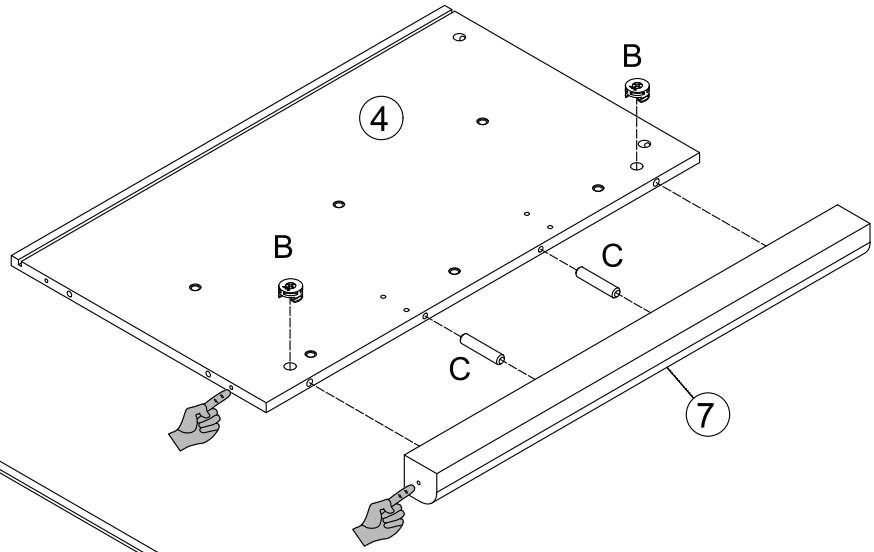
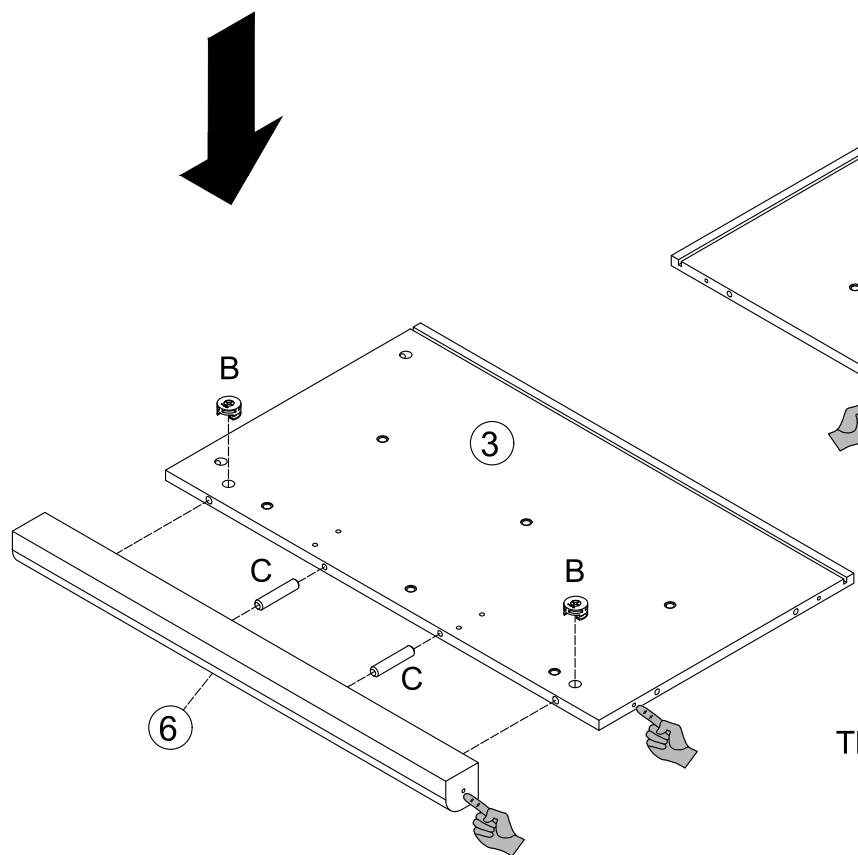
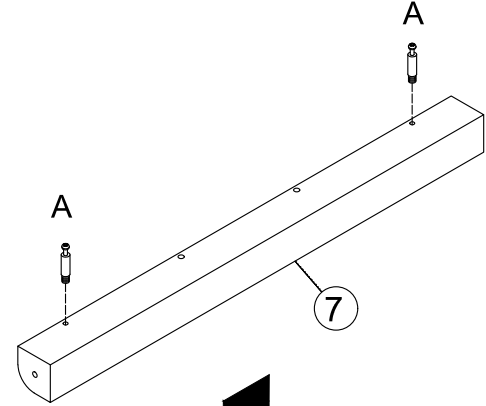
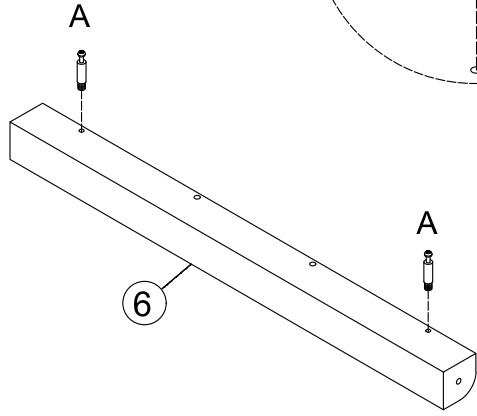
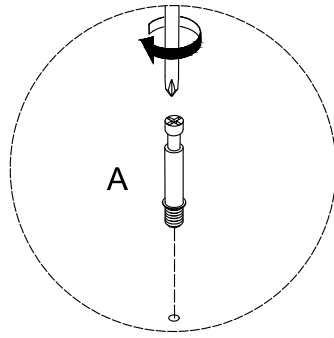
	A×4		B×4
			C×4

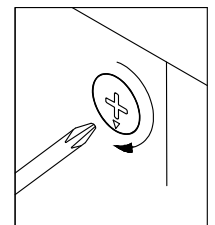
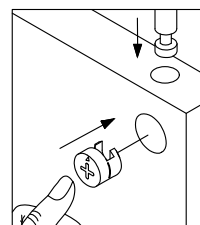

The indicated small holes are of the same size.



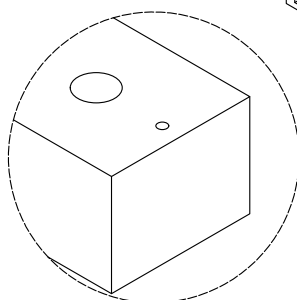
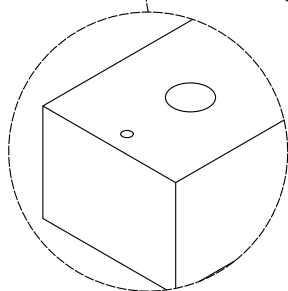
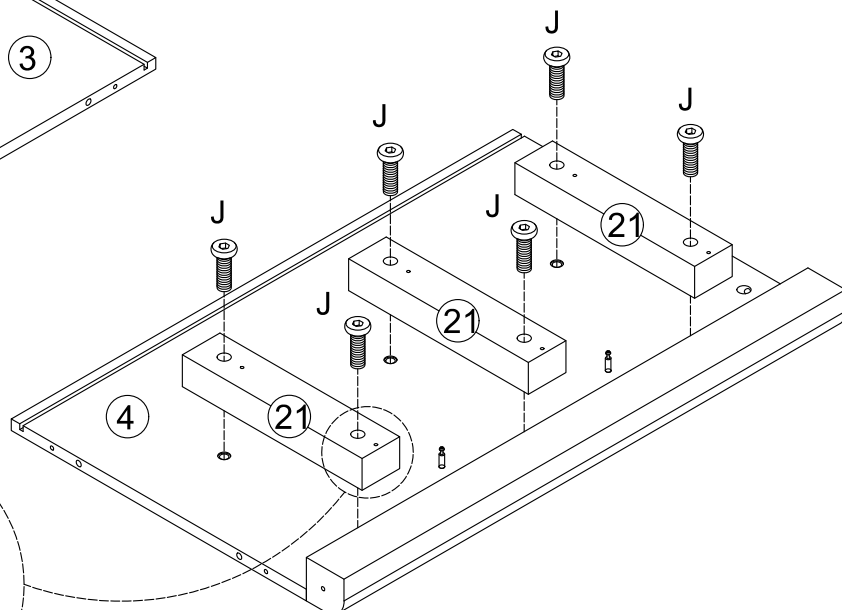
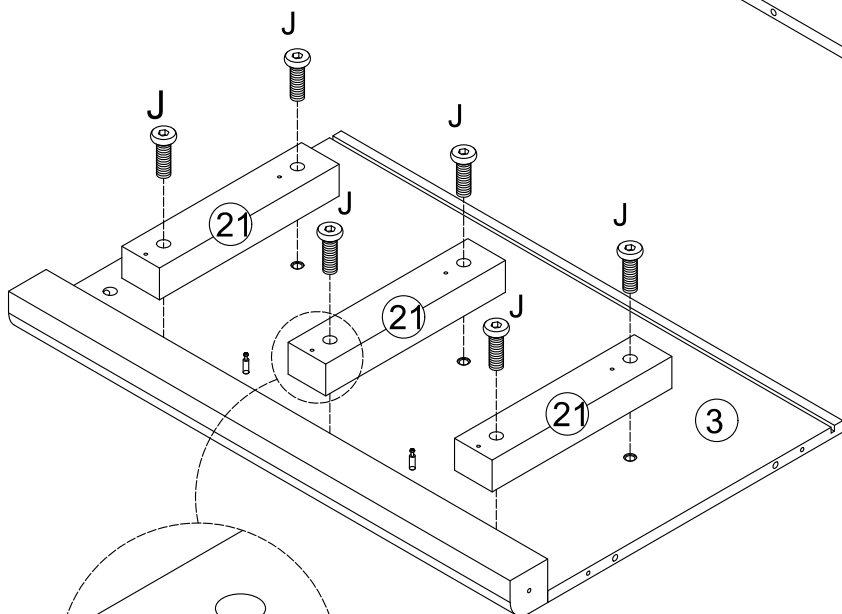
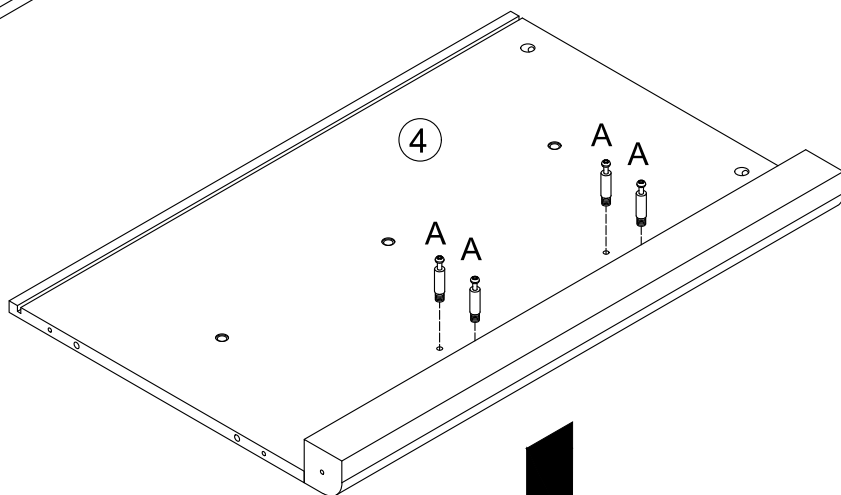
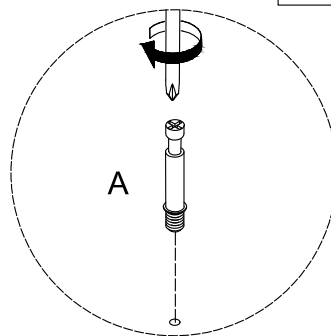
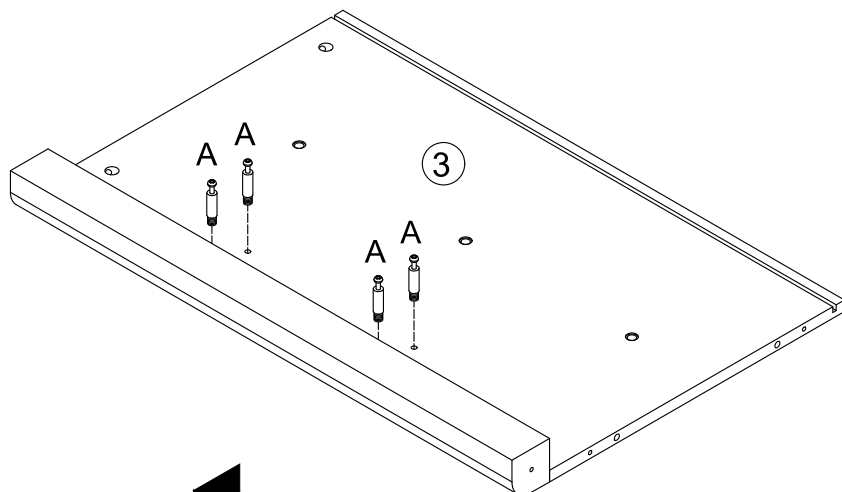

step4/step21

	A×8		J×12
			Q×1



Align the small hole at the bottom with the crossbar, as illustrated in the accompanying diagram.

	L×12		H×6
---	------	---	-----

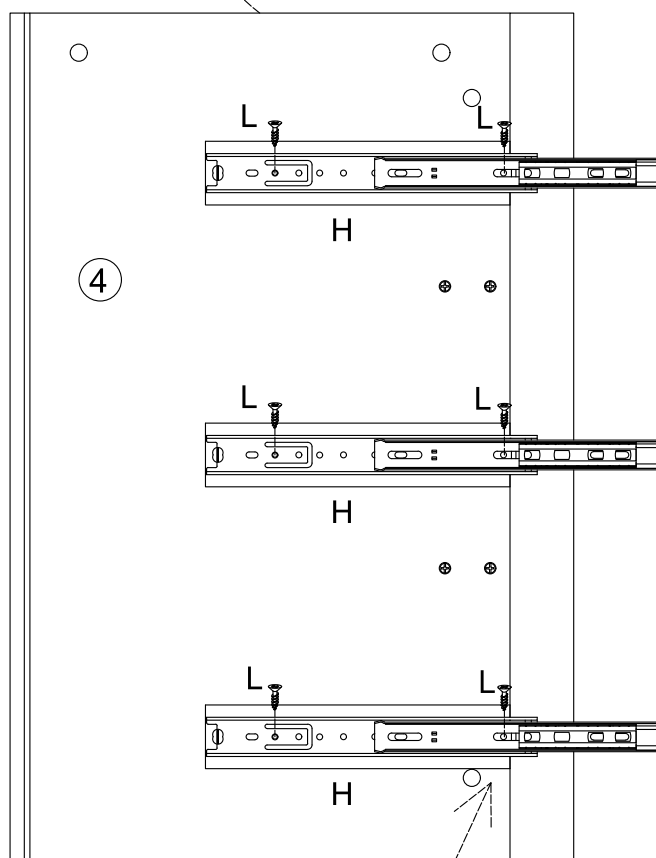
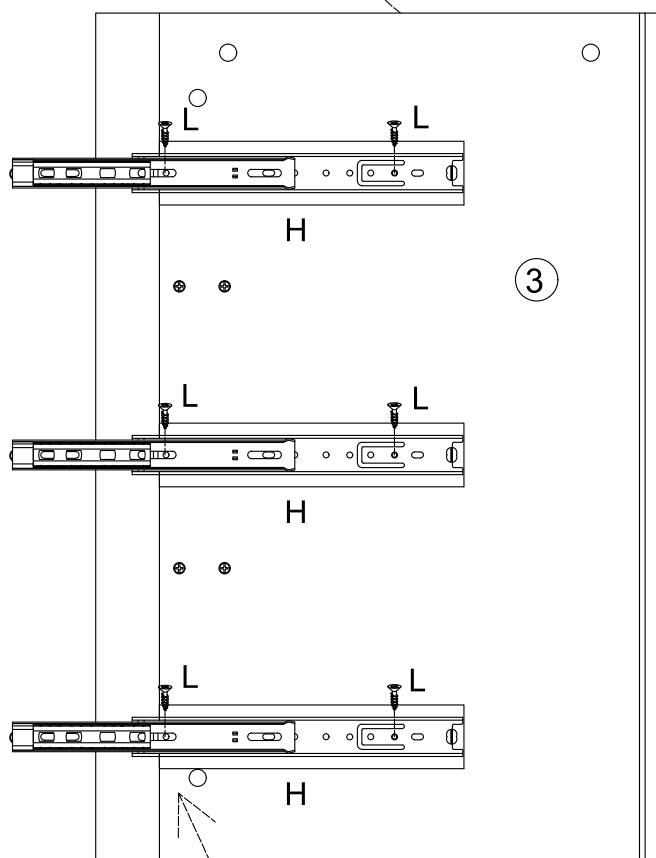
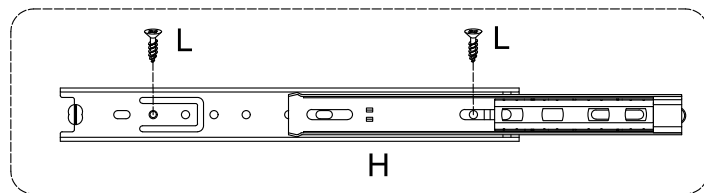
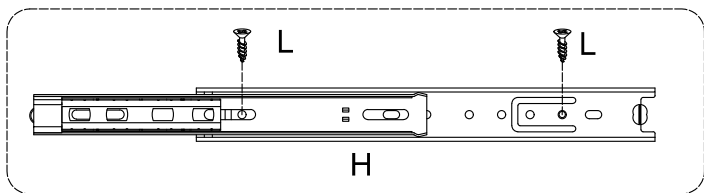

Please install this small hole first, and then install the second hole from the right side.

Please install this small hole first, and then install the second hole from the left side.

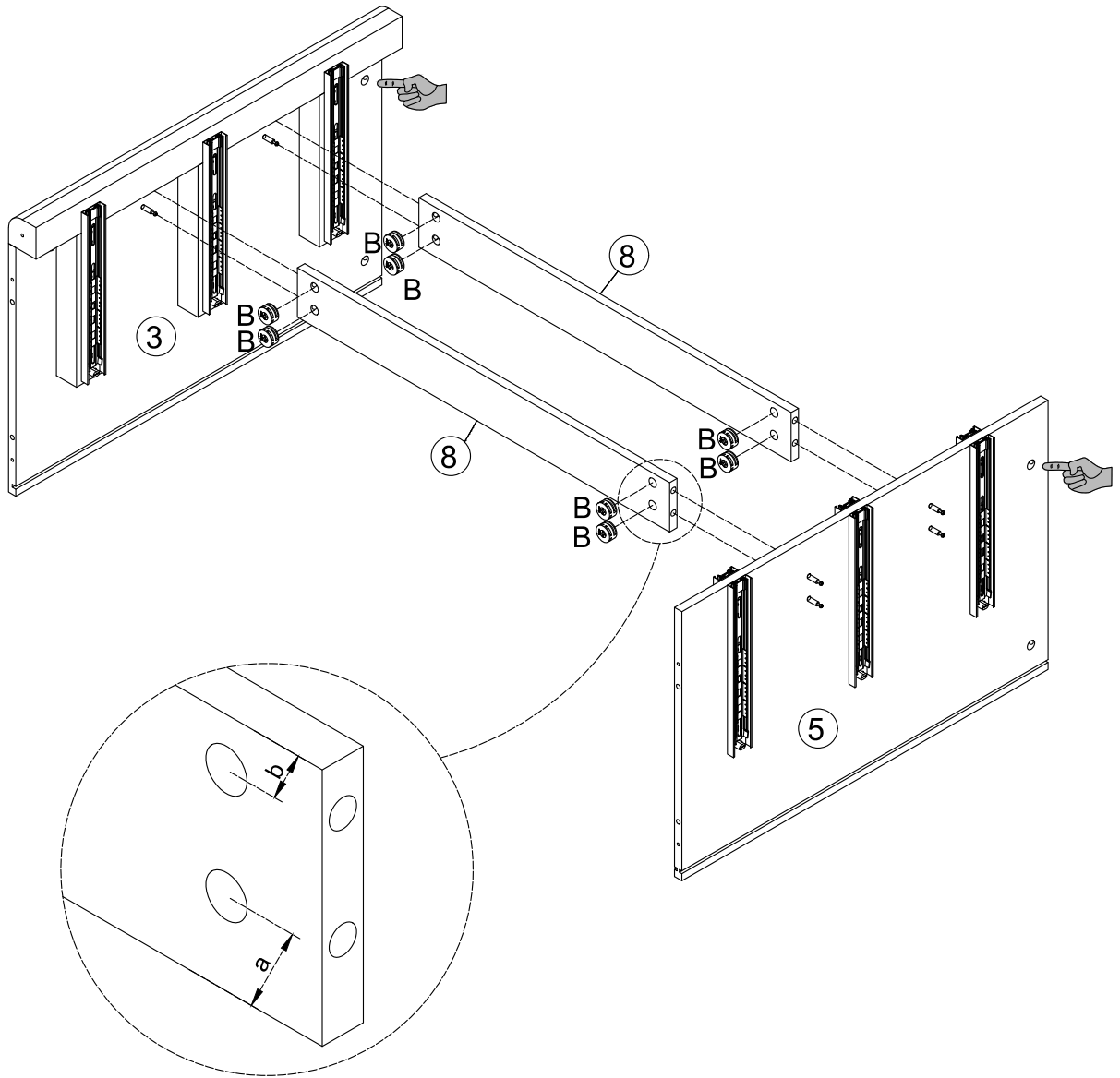

$a > b$

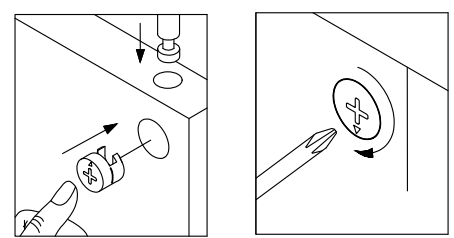

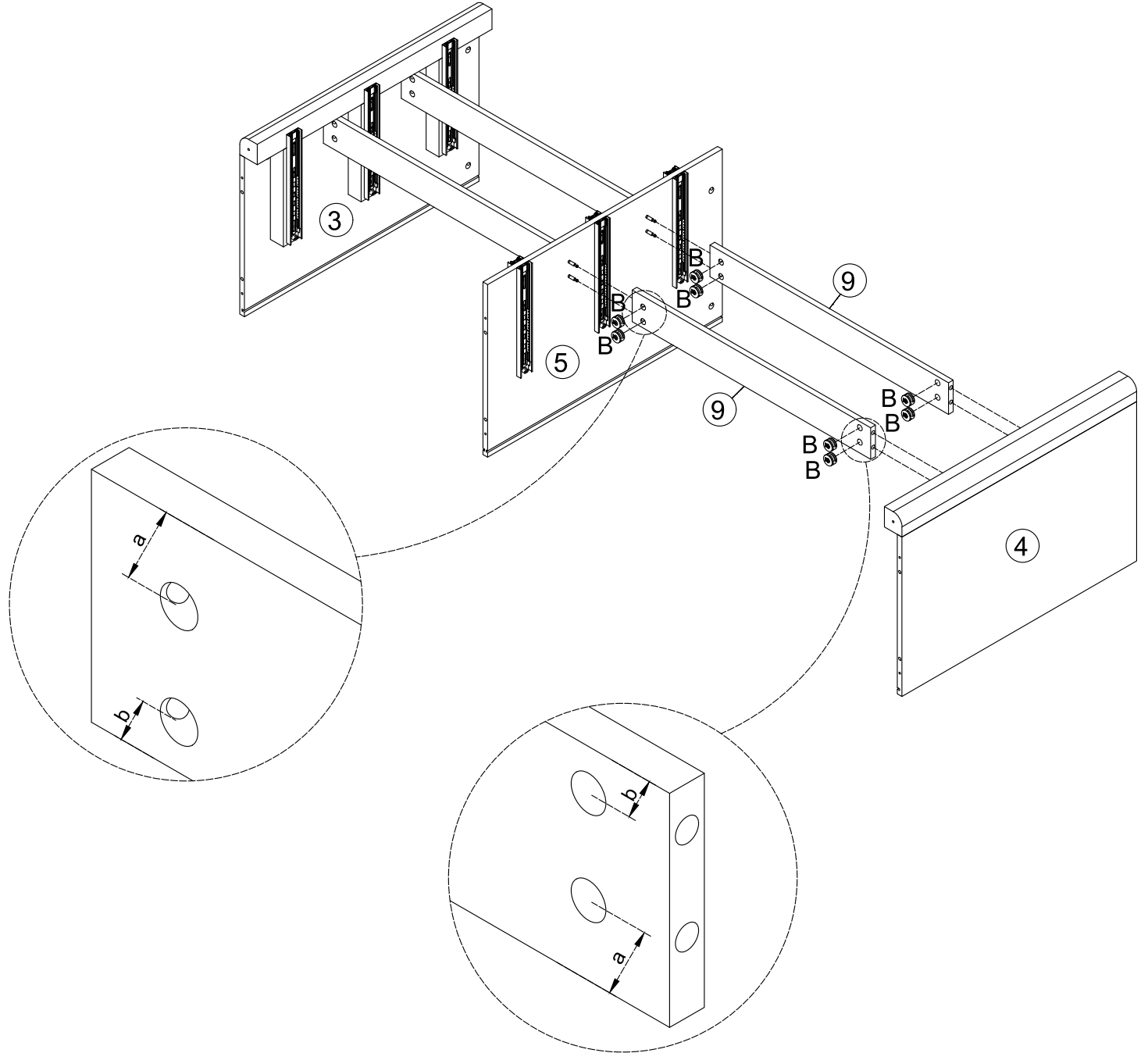

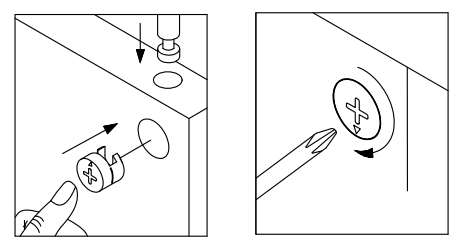

$a > b$



step8/step21

	A×6
	B×6
	C×8

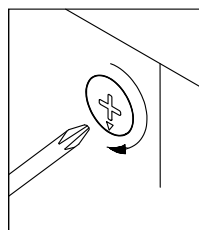
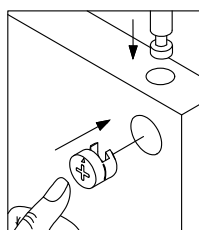
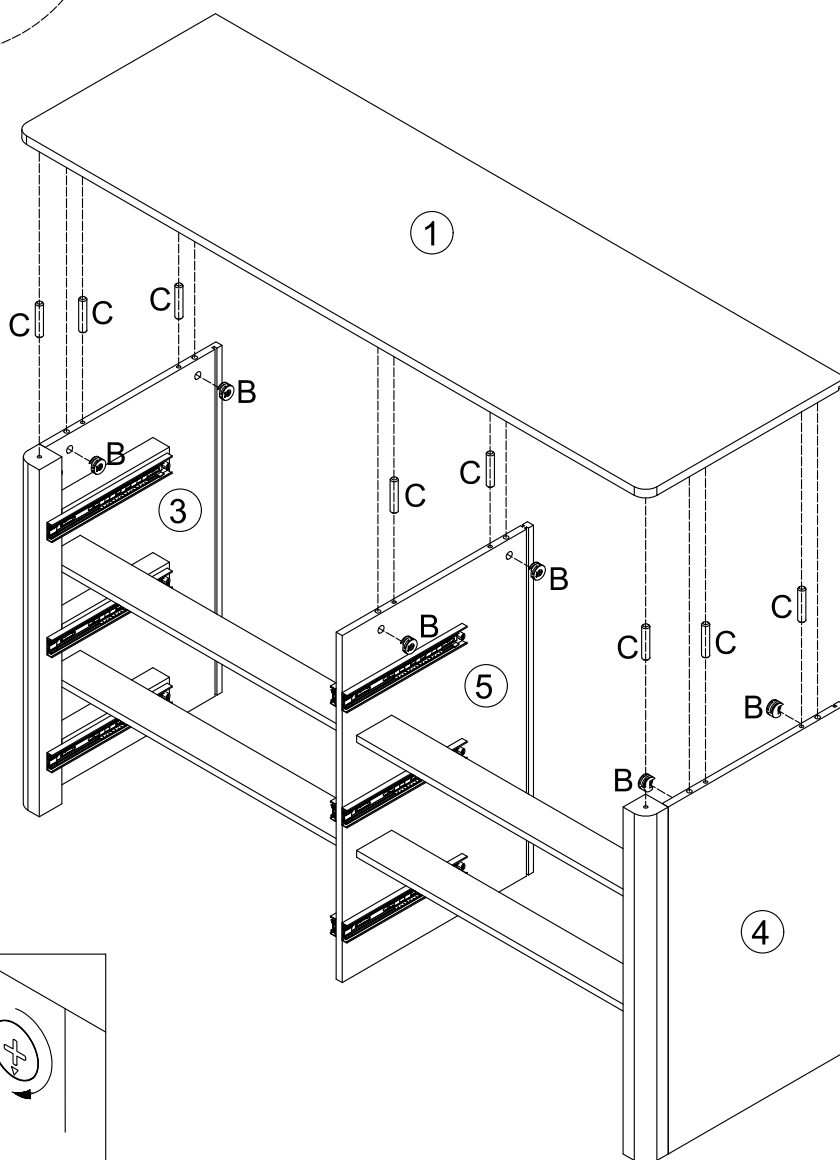
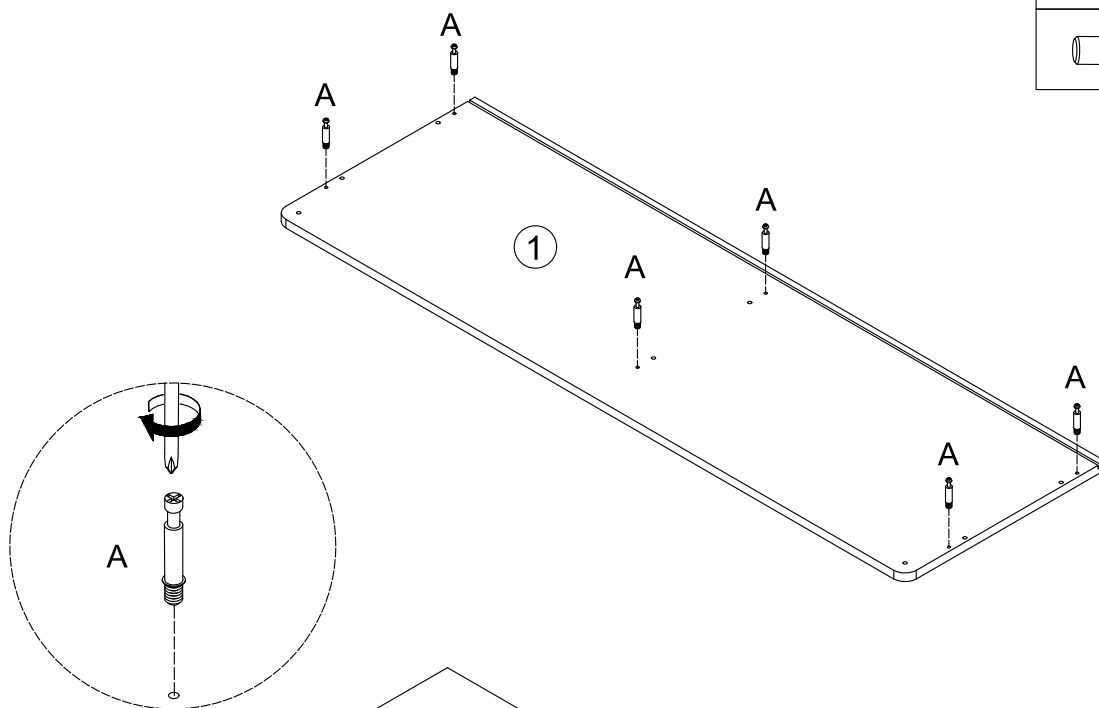

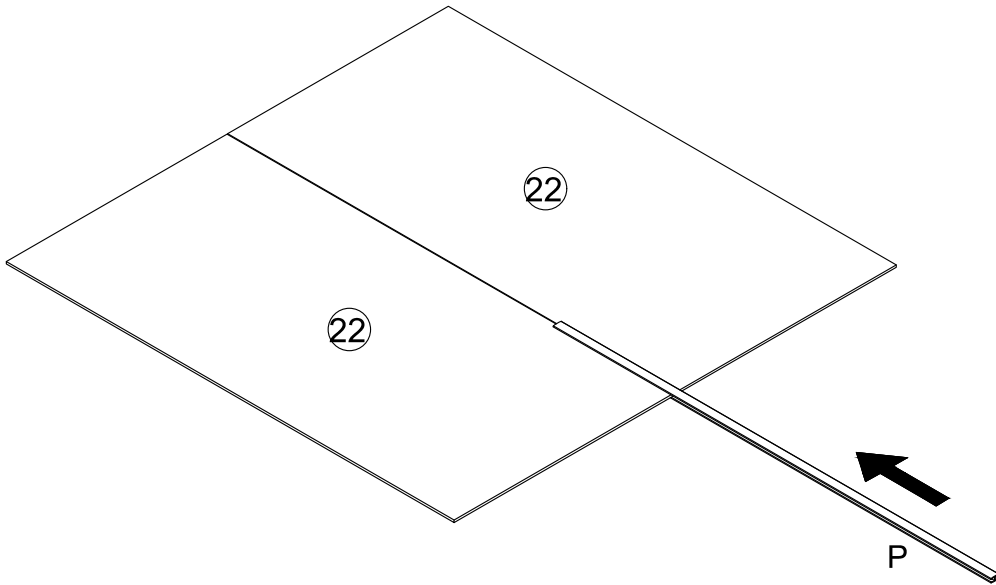
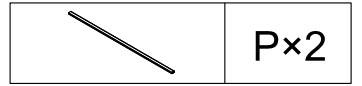



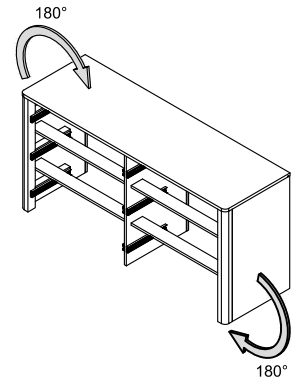

x2

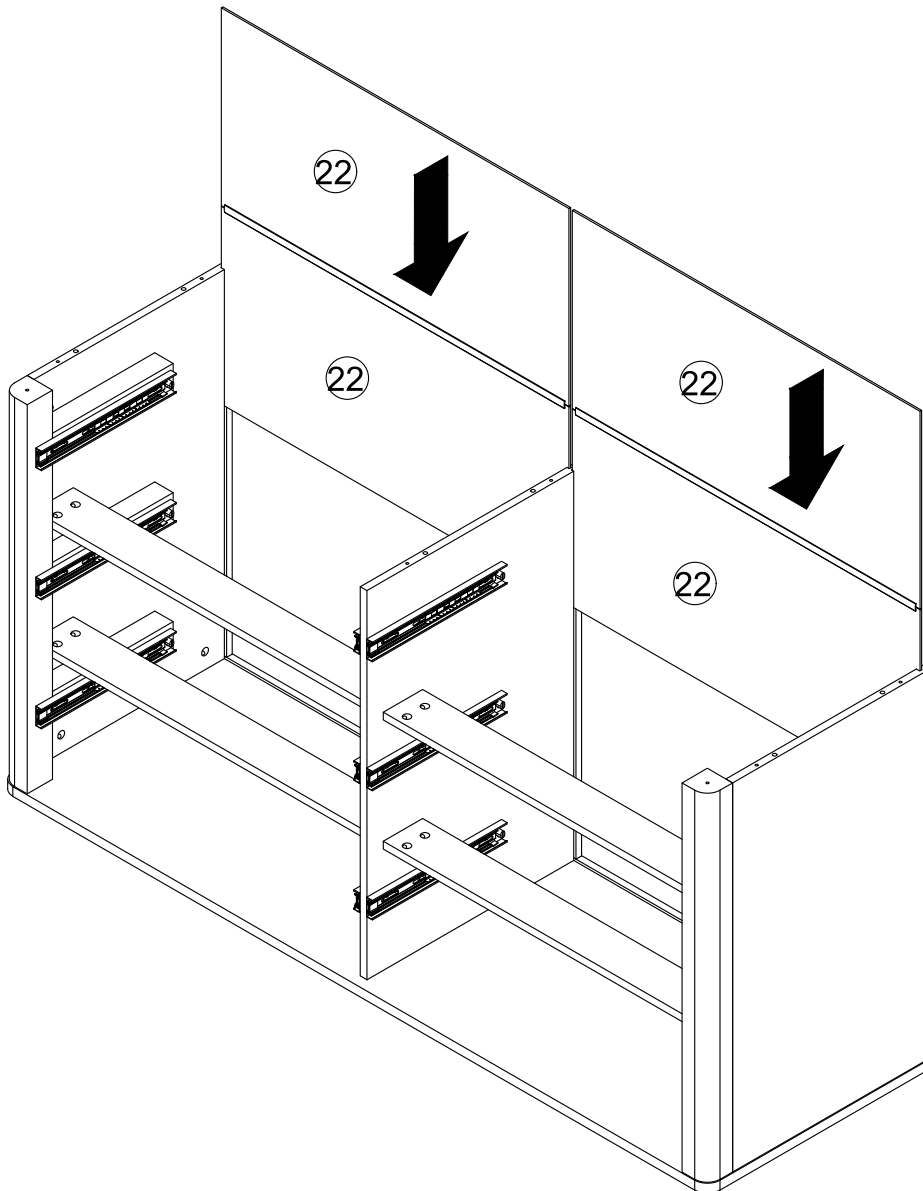



After locking it, the two lifted it simultaneously to prevent the middle wooden board from breaking



step11/step21

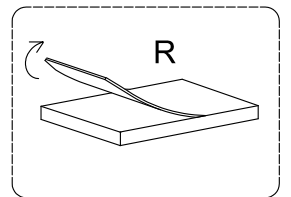
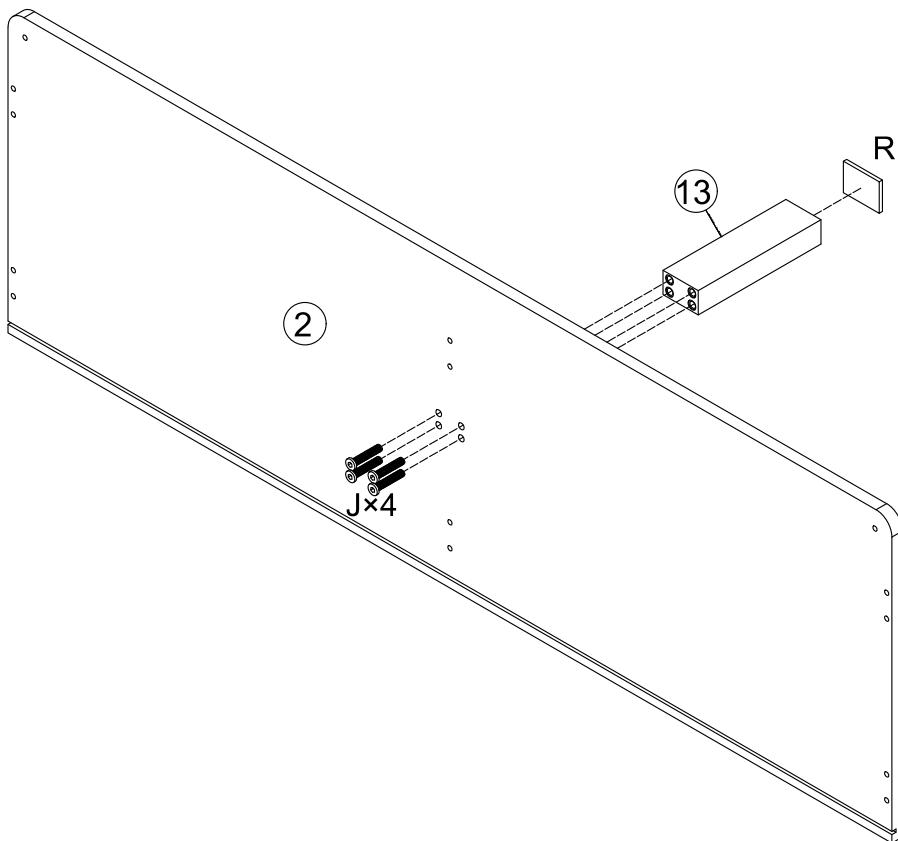
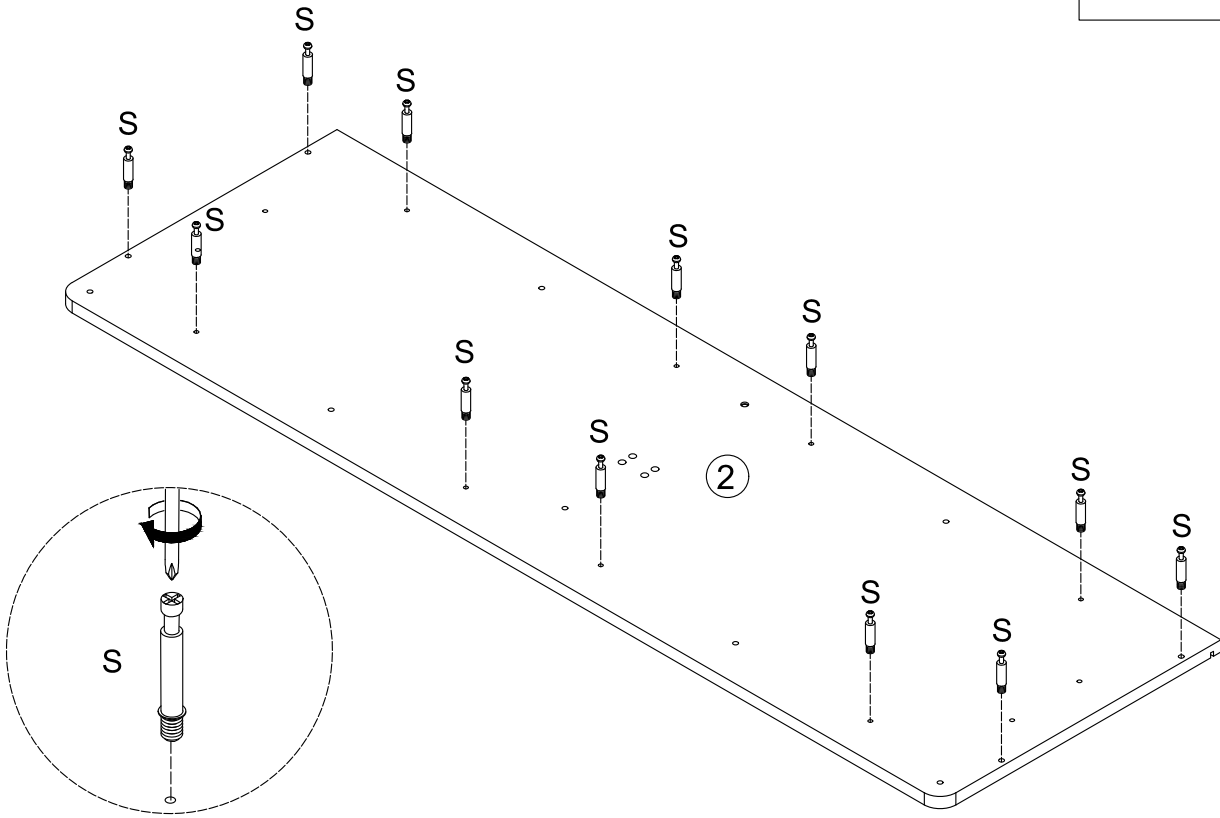

	J×4		R×1
			S×12



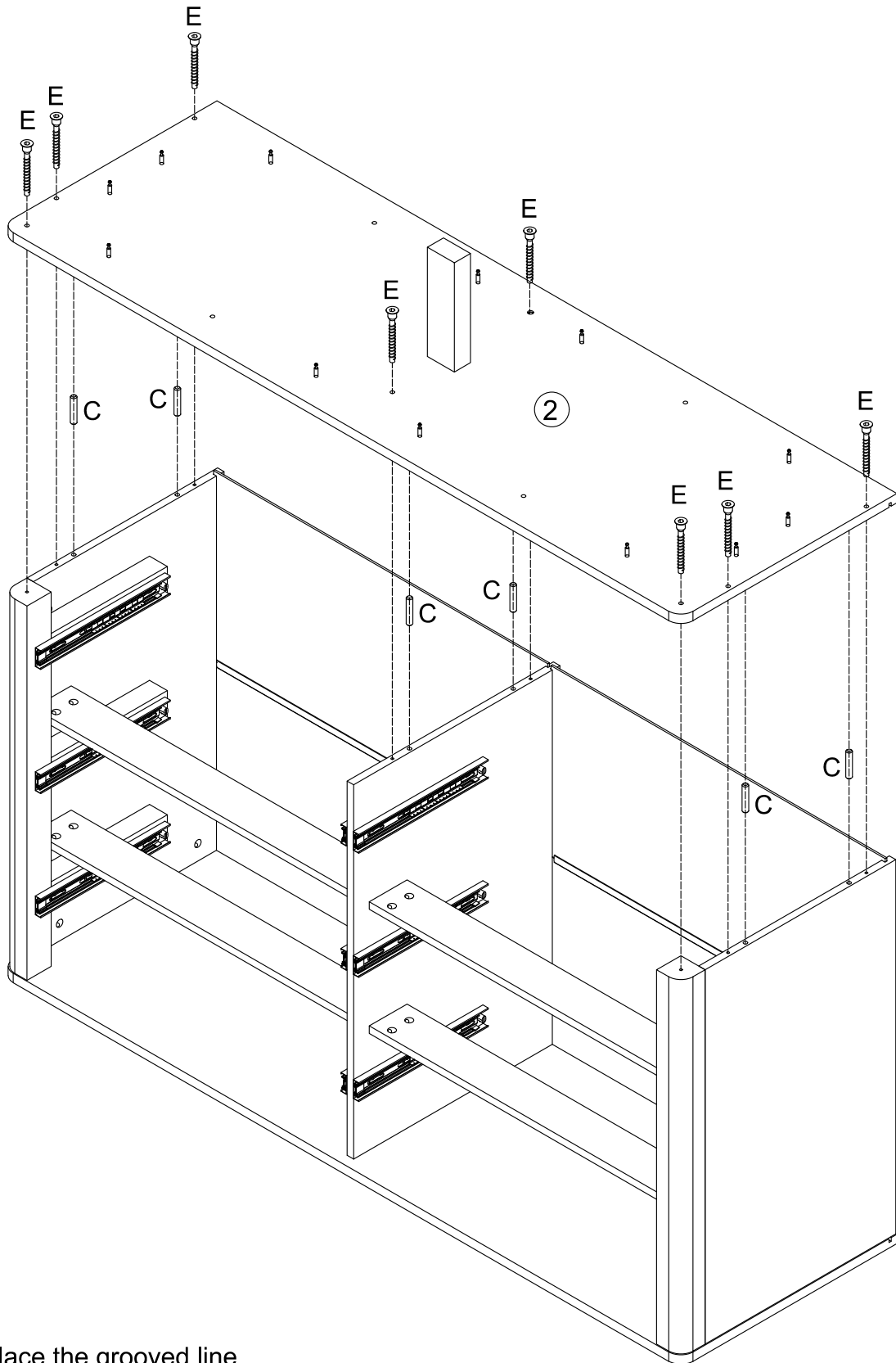

	C×6
	E×8



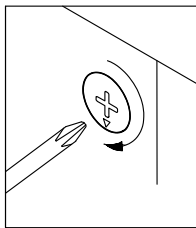
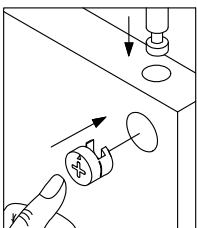
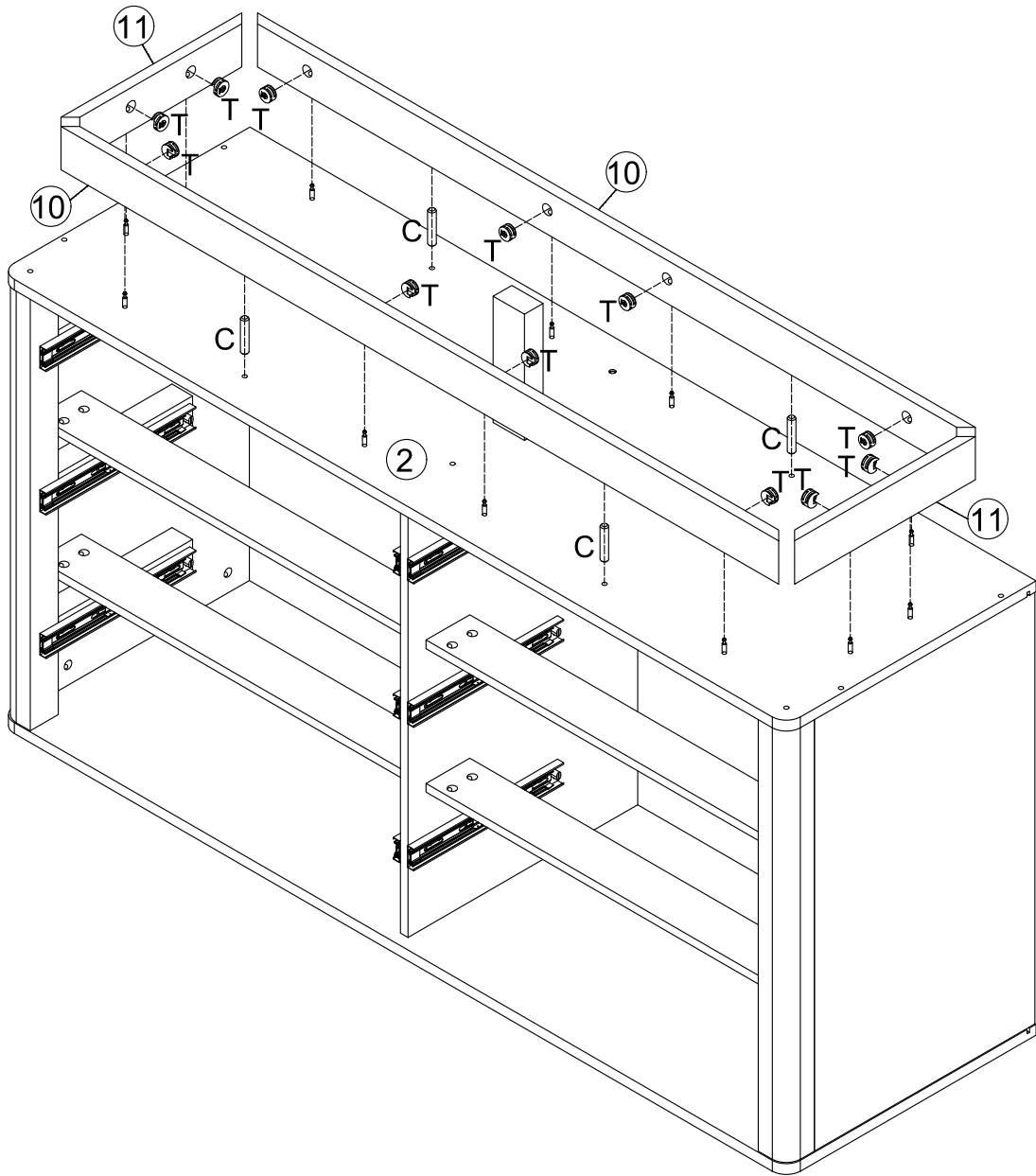

Please place the grooved line face down.

	C×4
	T×12



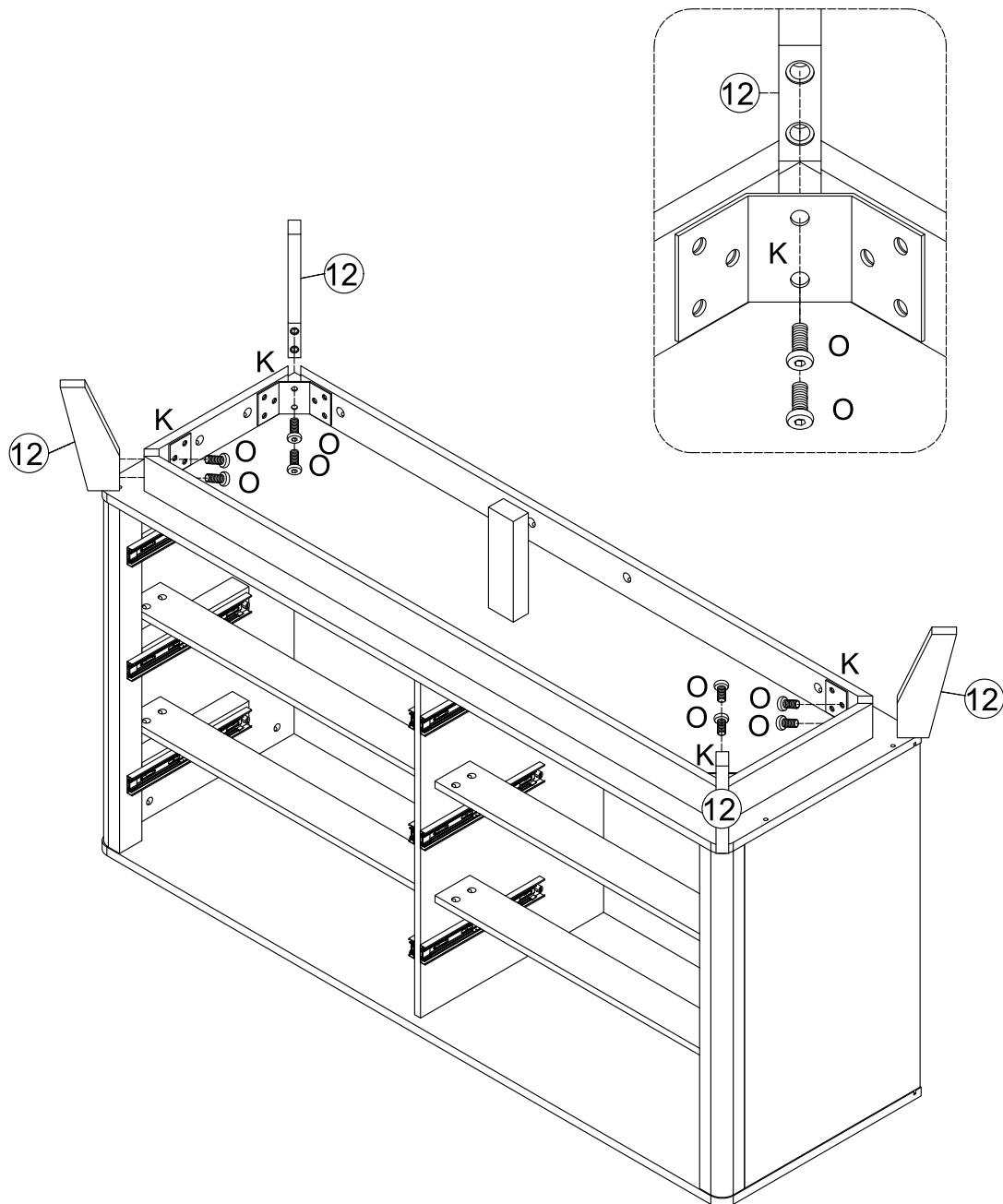

	K×4		O×8
--	-----	---	-----

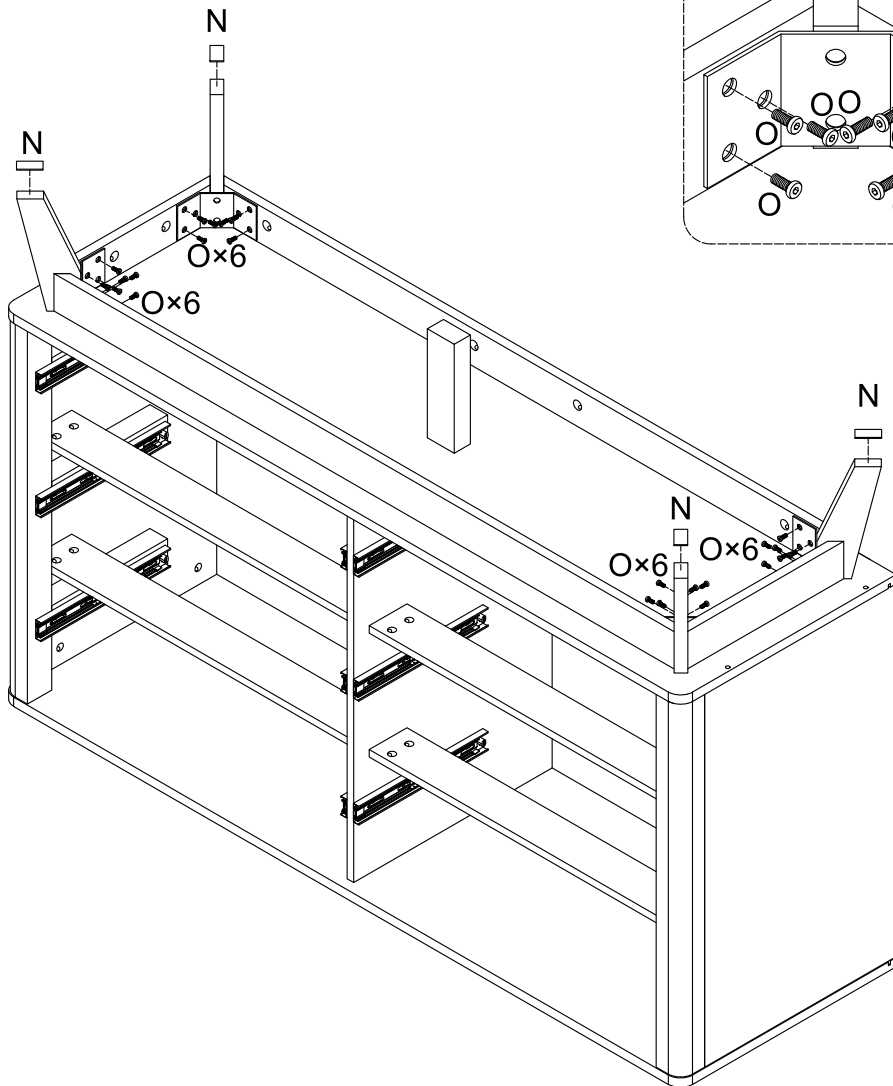
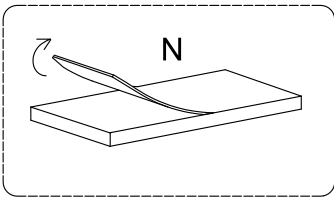

	N×4		O×24
--	-----	---	------



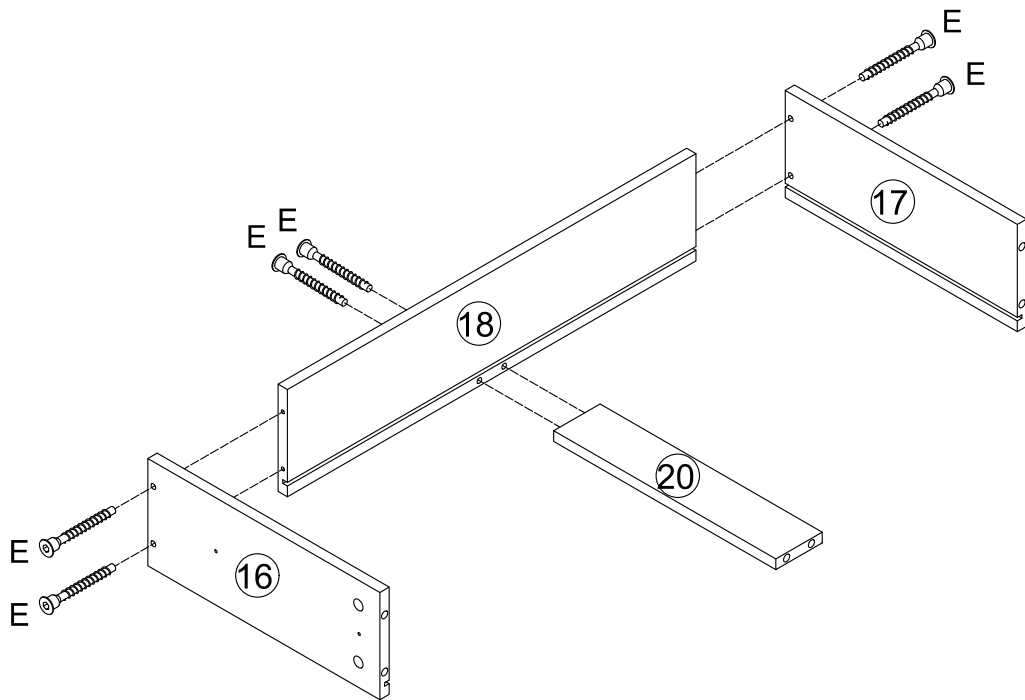
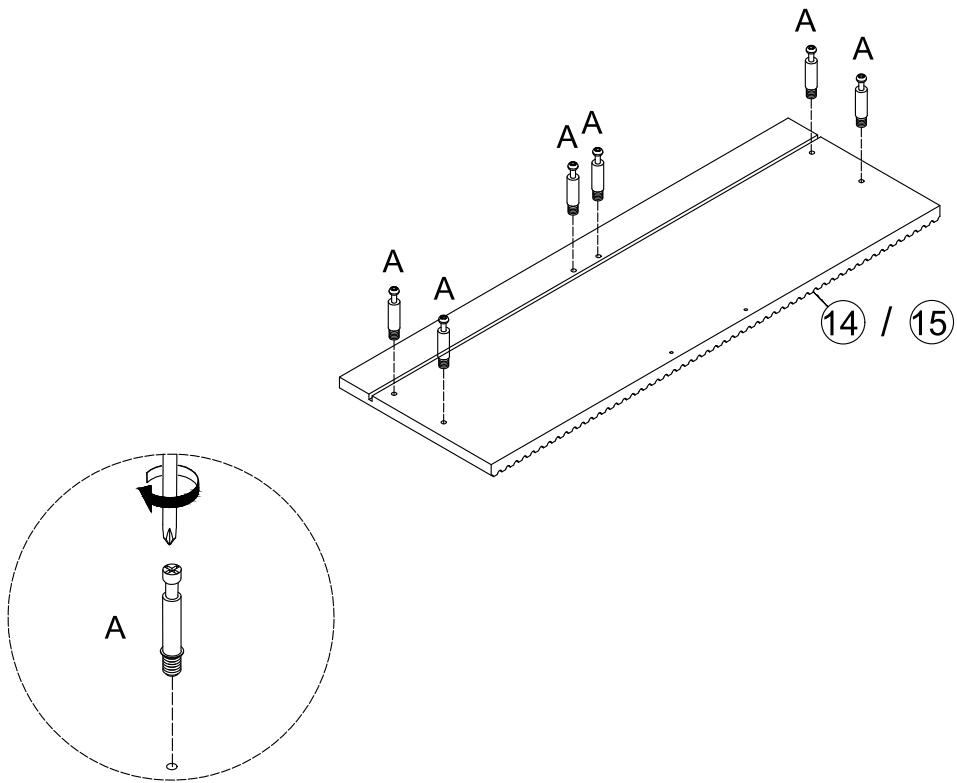

	A×36
	E×36





×6

step17/step21

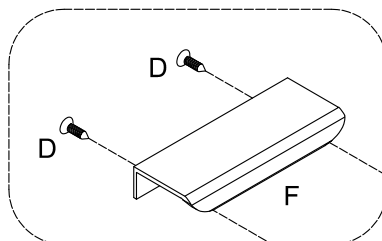
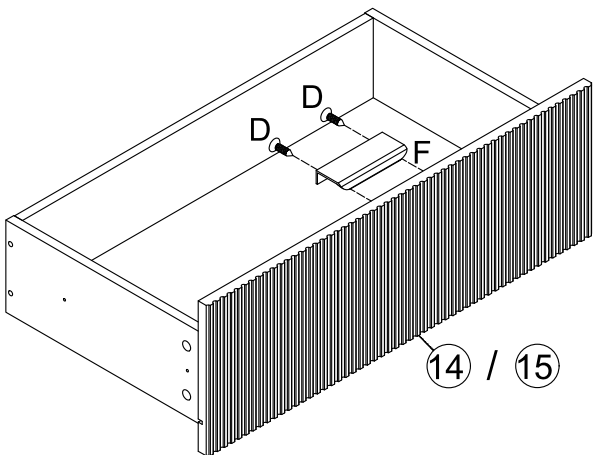
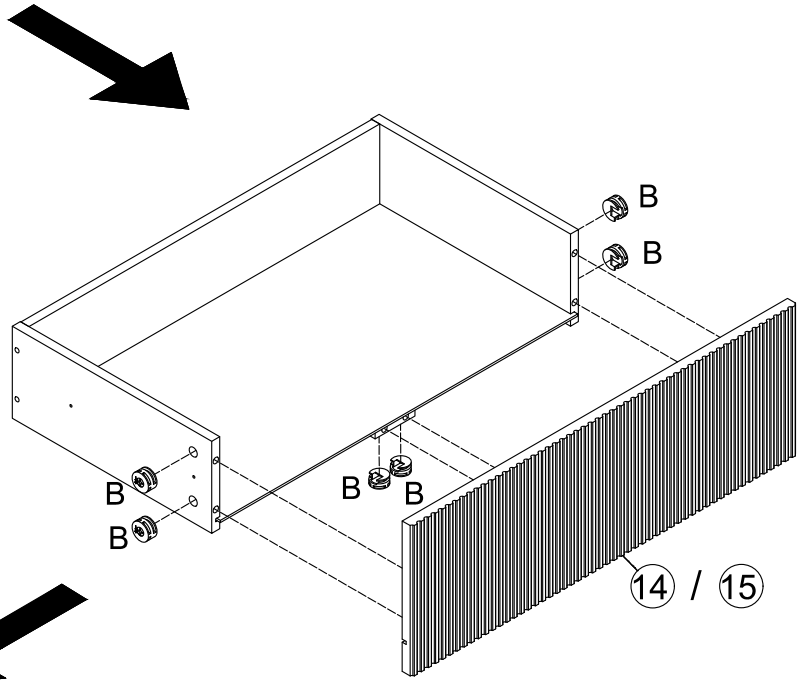
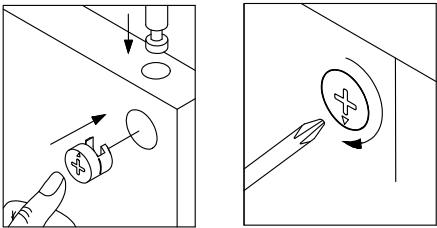
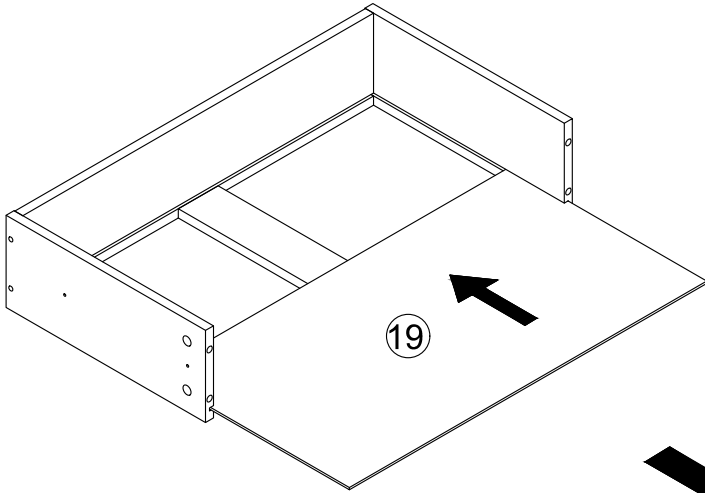
			B×36
	D×12		F×6





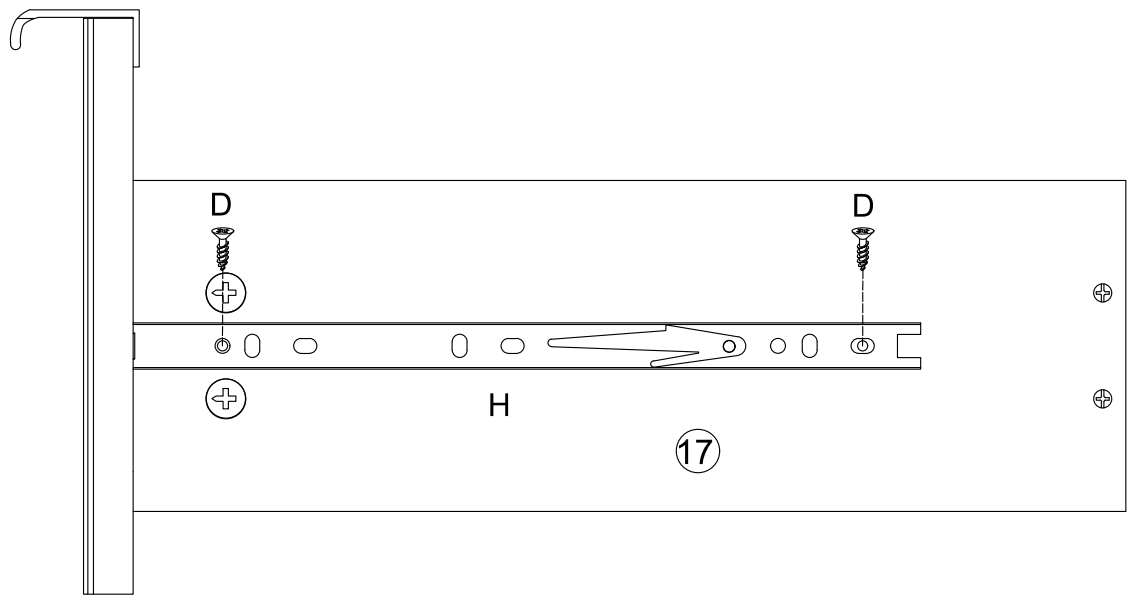
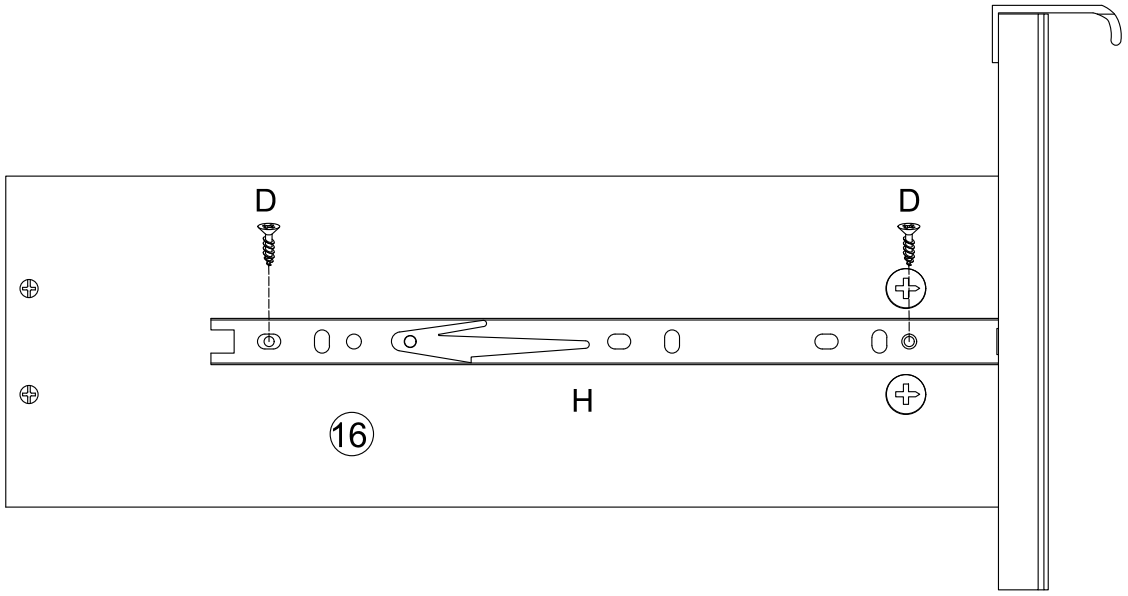

×6

	D×24		H×12
---	------	---	------

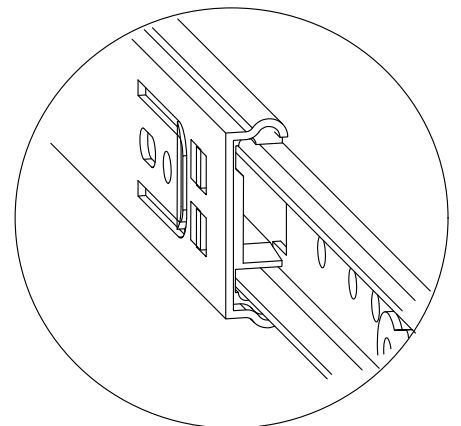
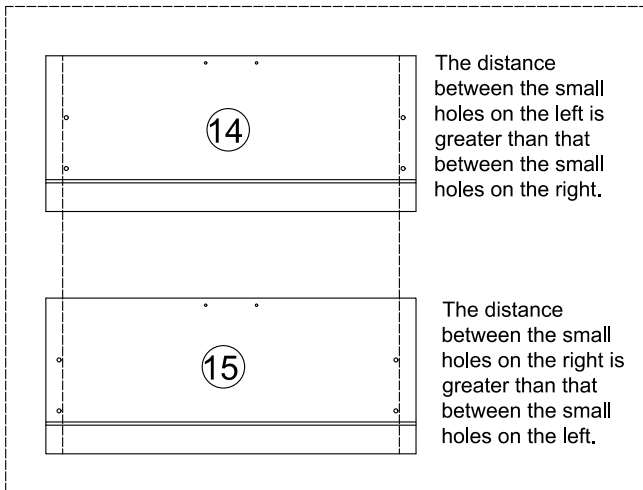
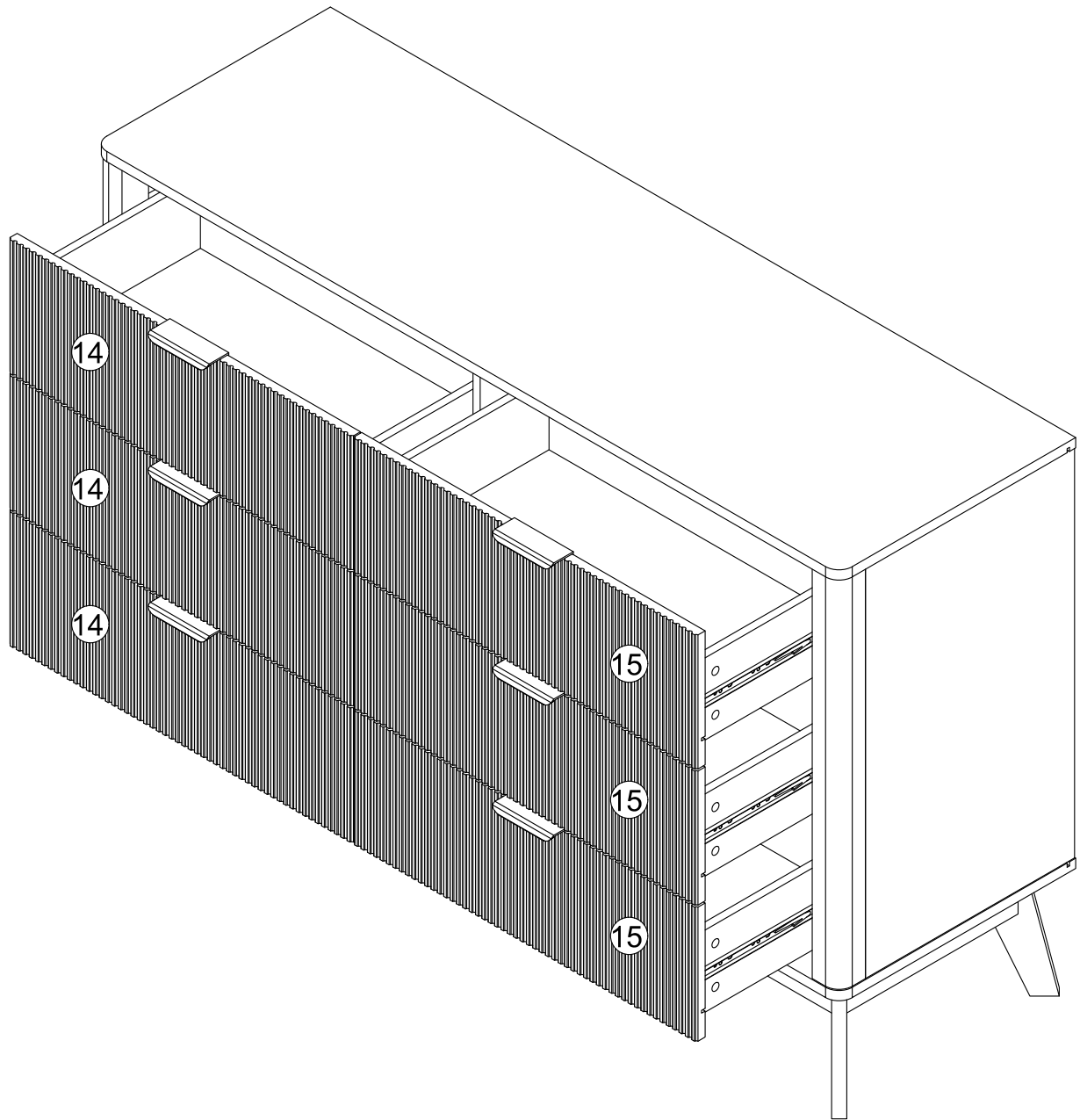

×6



			G×8
	I×2		L×10

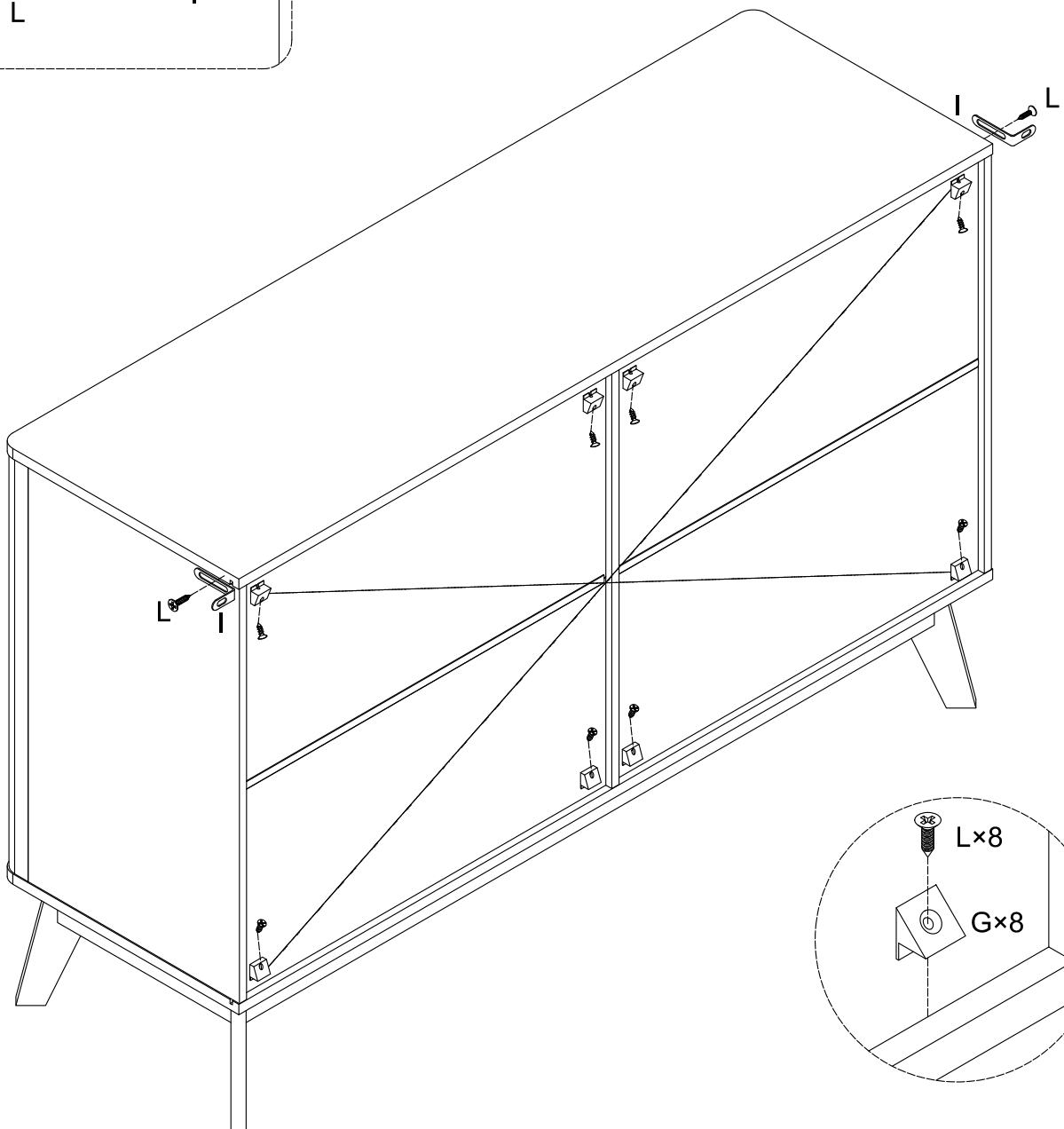
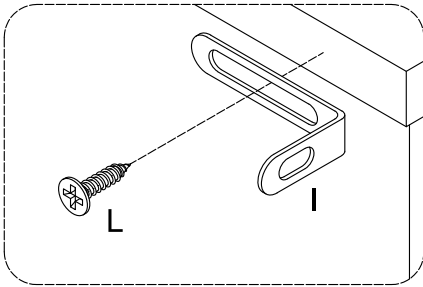

Prevent the uneven ground from causing the drawers to collide. After the diagonals are consistent, install the back plate buckle.

