

# OFFICE CHAIR

## Assembly Instruction

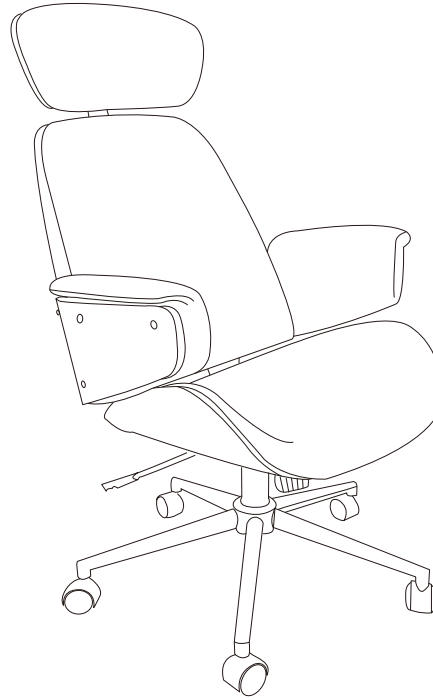



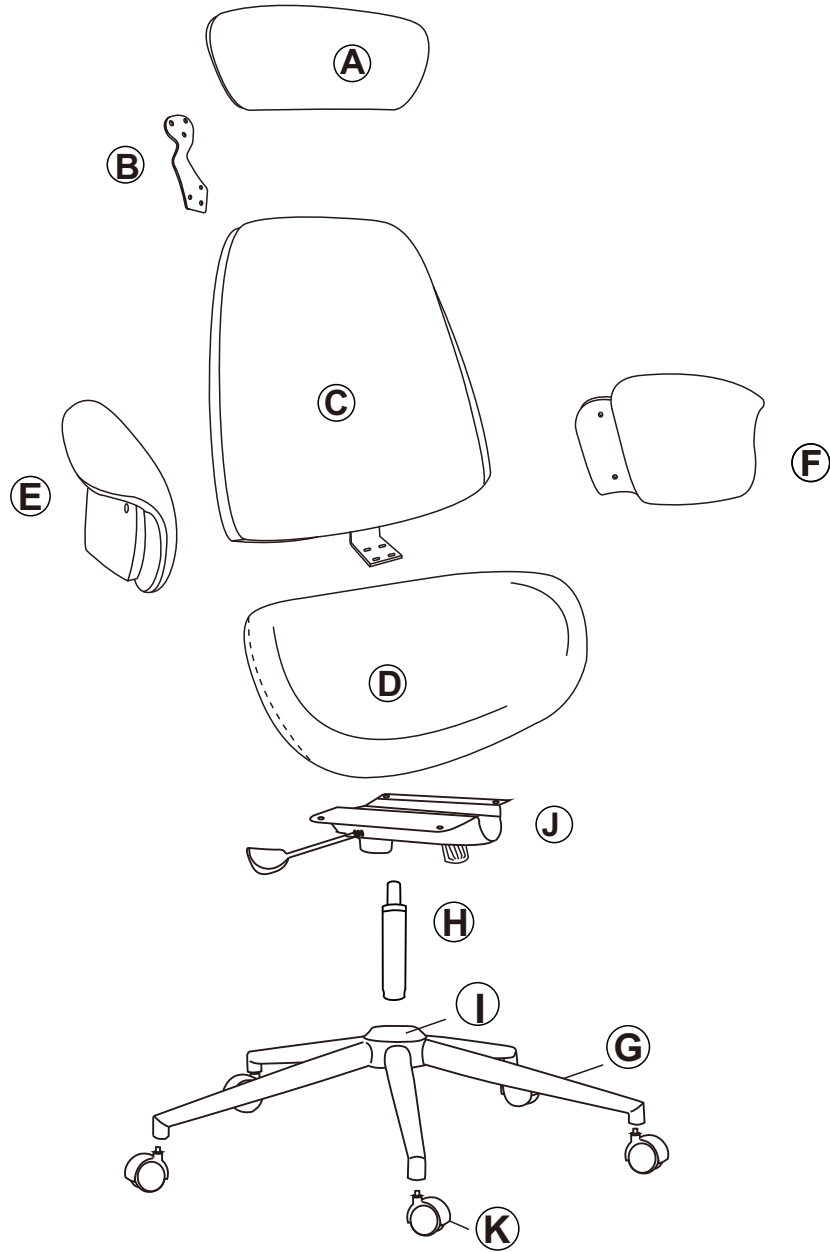

### **Dear Customers,**

**Thank you for purchasing our product. Please read this instruction manual carefully after receiving this product. It will help you assemble this product quickly, safely and correctly. You can keep this manual for future reference.**











# CHAIR

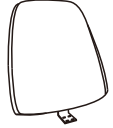

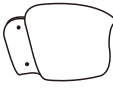
## Hardware parts

<b>a</b> M6*30MM  x6	<b>b</b> M6*25MM  x8	<b>c</b> M6*20MM  x16	<b>d</b> Plastic gasket  x4	<b>e</b> Allen Key  x1
---	---	--	--	---

## Main structure accessories

<b>A</b> Headrest  x1	<b>B</b> Connecting Metal  x1	<b>C</b> Backrest  x1	<b>D</b> Seat Cushion  x1
<b>E</b> Armrest-L  x1	<b>F</b> Armrest-R  x1	<b>G</b> Legs  x5	<b>H</b> Gas-lift  x1
<b>I</b> Base  x1	<b>J</b> Mechanism  x1	<b>K</b> Castors  x5	

# Kind Reminder:

Due to the size of our product, it would be easier to assemble it with your partner together.

## STEP 1

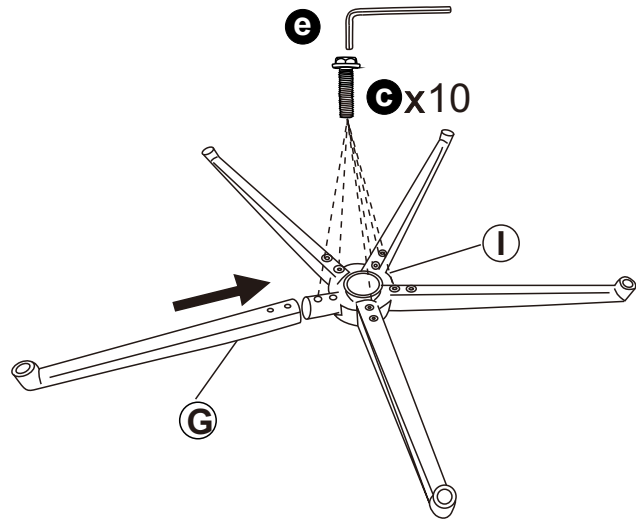

**C** x10

**e** x1

## STEP 2

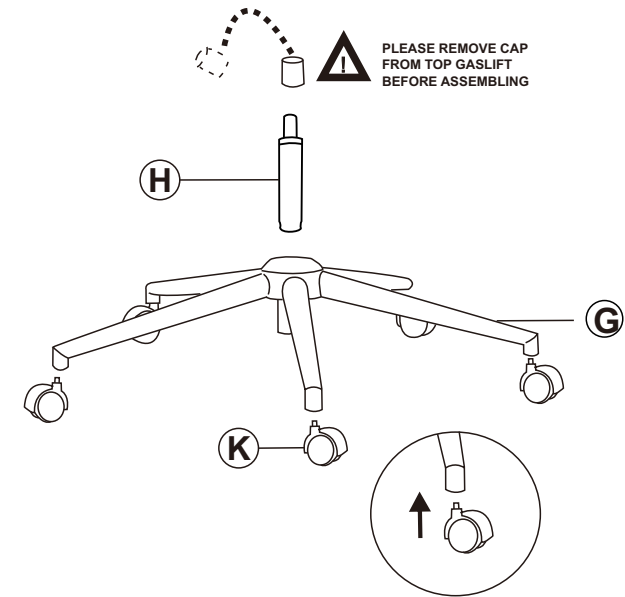

PLEASE REMOVE CAP  
FROM TOP GASLIFT  
BEFORE ASSEMBLING

### Note:

Please kindly note that the cap should be removed from the top of the gaslift before assembling. Please align the holes of base, then press the castors firmly into them.

## STEP 3

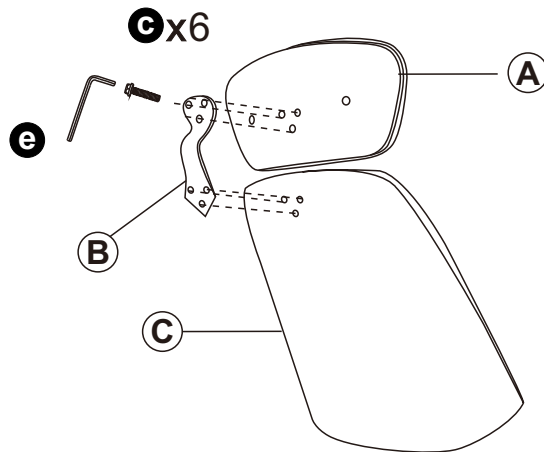

**C** x6

**e** x1

### Note:

Screwing all bolts **C** 50% firstly, make sure the headrest is straight, then tighten all bolts 100%.

## STEP 4

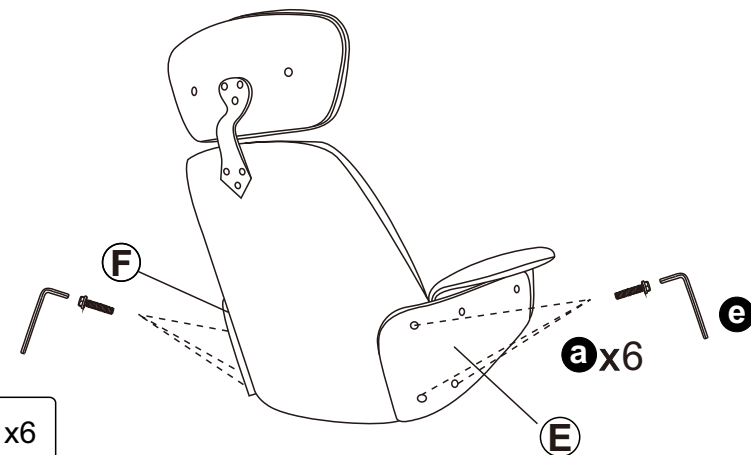

**a** x6

**e** x1

### Note:

Screwing all bolts **a** 50% firstly, then tighten all bolts 100%. It will help you assemble it easily.

## STEP 5

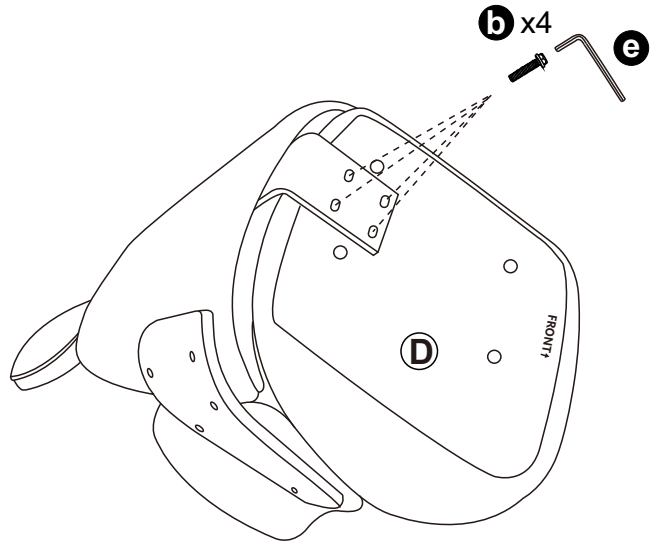

**b** x4

**e** x1

## STEP 6

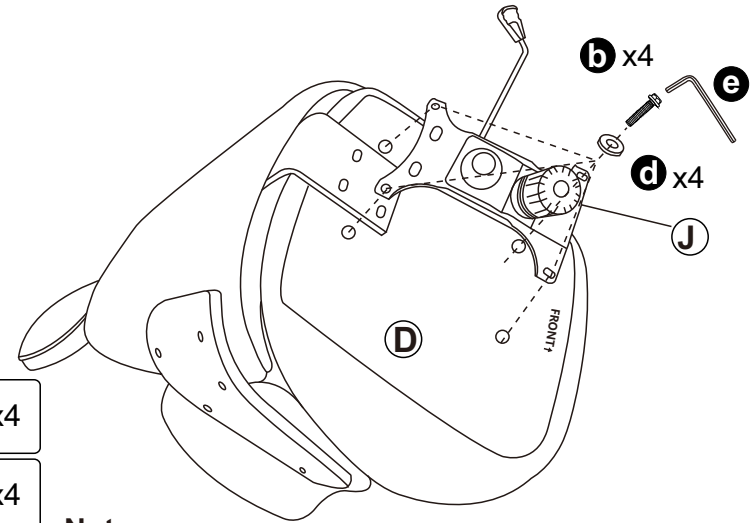

**d** x4

**b** x4

**e** x1

### Note:

Make sure the "Front" direction of Mechanism **J** and Seat Cushion **D** are the same.

## STEP 7

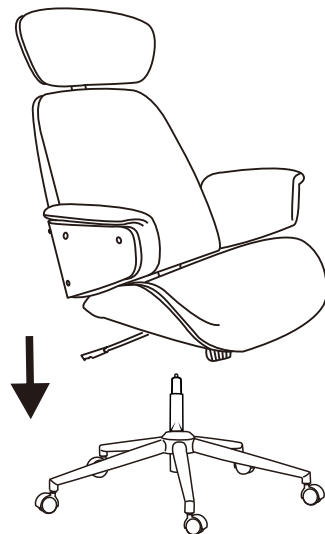

### Note :

Before using the chair, please kindly check all screws are fully tightened.

## STEP 8

