

Assembly Instructions

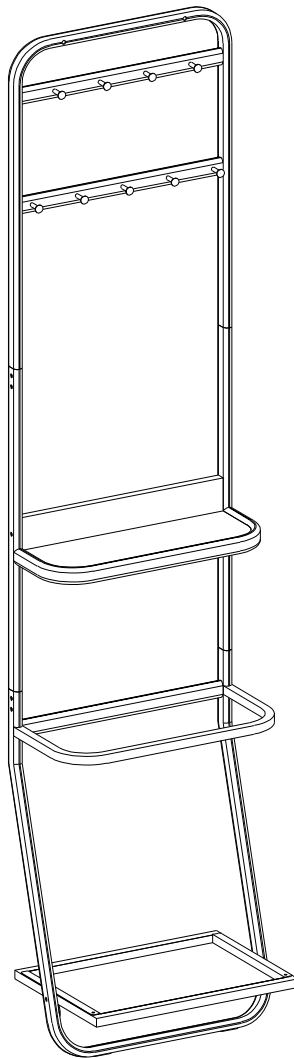

General Assembly Guidelines

- I. Ensure that all parts and hardware are available before beginning assembly.
- II. Follow each step carefully to ensure the proper assembly of this product.
- III. Two people are recommended for ease in the assembly of this product.
- IV. The three main types of hardware used to assemble this product are: wood dowels, screws and bolts.
- V. The provided glue is to secure wood dowels in place. When first inserting dowels, locate the appropriate hole for the dowel, place a small amount of glue in the hole and insert the dowel. Wipe away excess glue immediately.

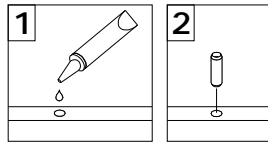

In future assembly steps when dowels are necessary to attach assembly parts together, place a small amount of glue on the end of the dowel before attaching parts together. Wipe away excess glue immediately.

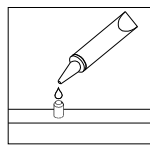

- VI. A Phillips head screwdriver is required for the assembly of this product .

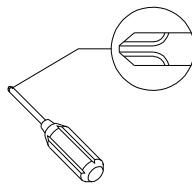

- VII. Power tools should not be used to assemble this product.

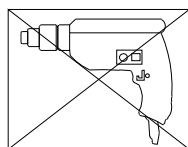





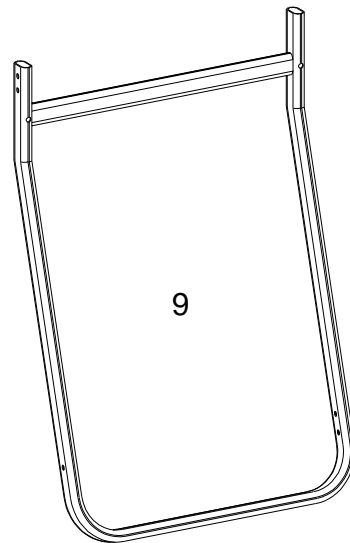
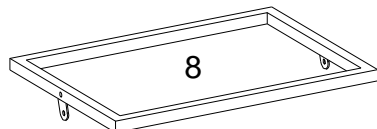
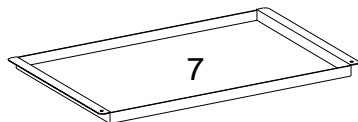
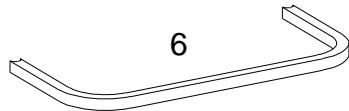
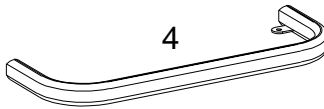
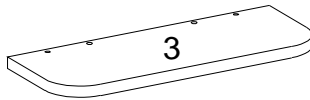
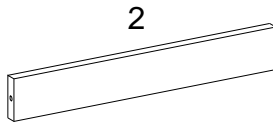
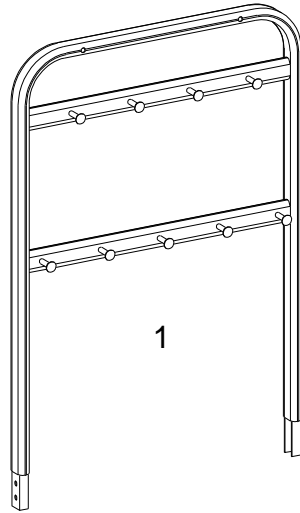



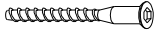
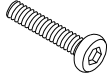

- VIII. Drill may be needed for securing product to wall.

Parts List

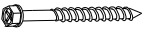

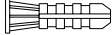
Hardware List

A		Ø8x30mm	Wooden dowel	2	pcs
B		Ø1/4"x12mm	Bolt	14	pcs
C		Ø1/4"x25mm	Bolt	2	pcs
D		Ø1/4"x50mm	Bolt	2	pcs
E		Ø6x38mm	Screw	2	pcs
F		Ø1/4"x50mm	Bolt	4	pcs
G		M 4	Hex key	1	pc
H			Nut	2	pcs
J		Ø6x64mm	Screw	2	pcs
K			Flat washer	2	pcs
L			Nut	2	pcs
M			EVA pad	2	pcs
N			Glue tube	1	pc

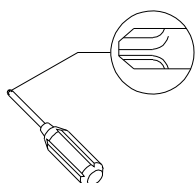

Philips head screwdriver required for assembly
(not included)

*The hardware quantities listed above are required for proper assembly.
Some extra hardware may also have been included.*

Step 1

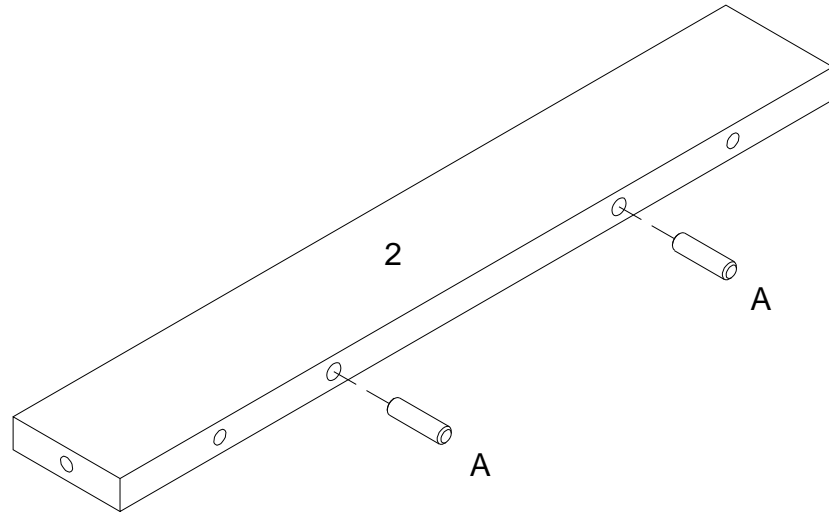

Insert wooden dowel (A) into part (2) as per diagram.

Step 2

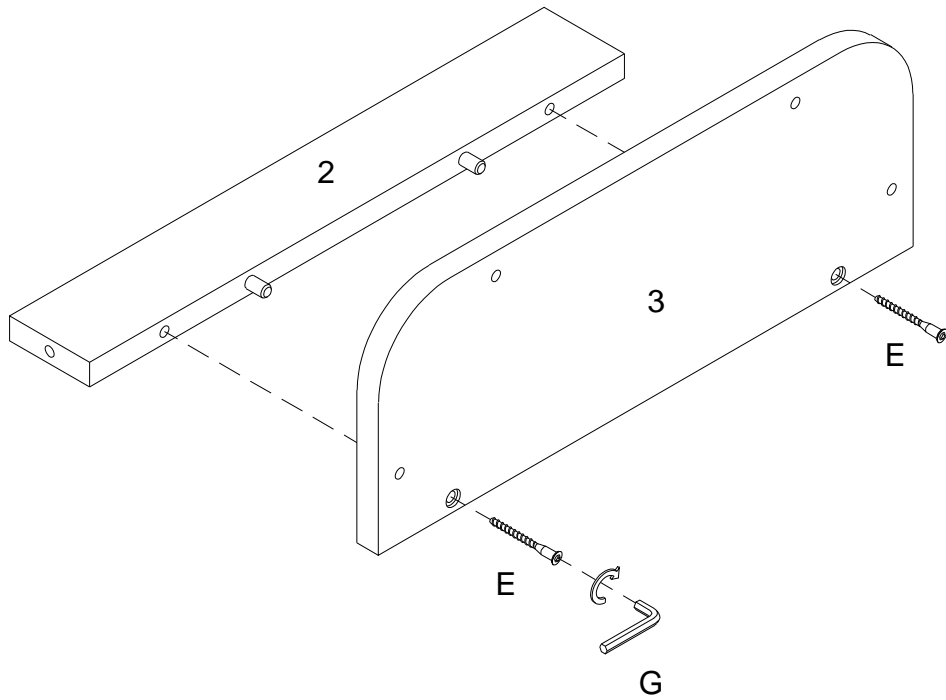

Using screw (E) attach part (3) into part (2) with Hex key (G) as per diagram.

Step 3

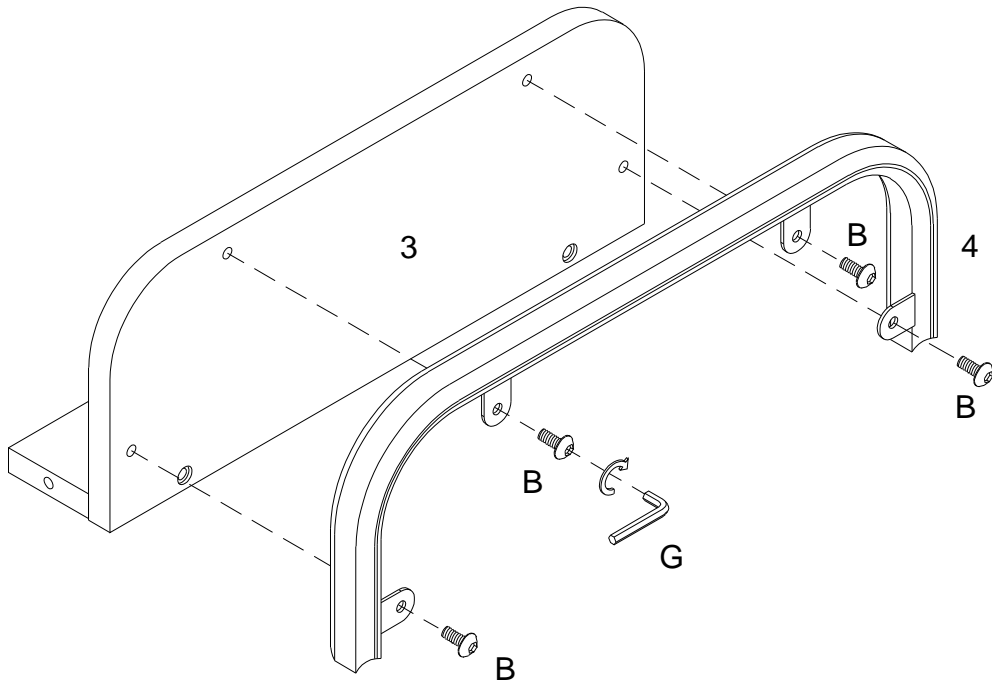

Using Bolt (B) attach part (4) to part (3) with Hex key (G) as per diagram.

Step 4

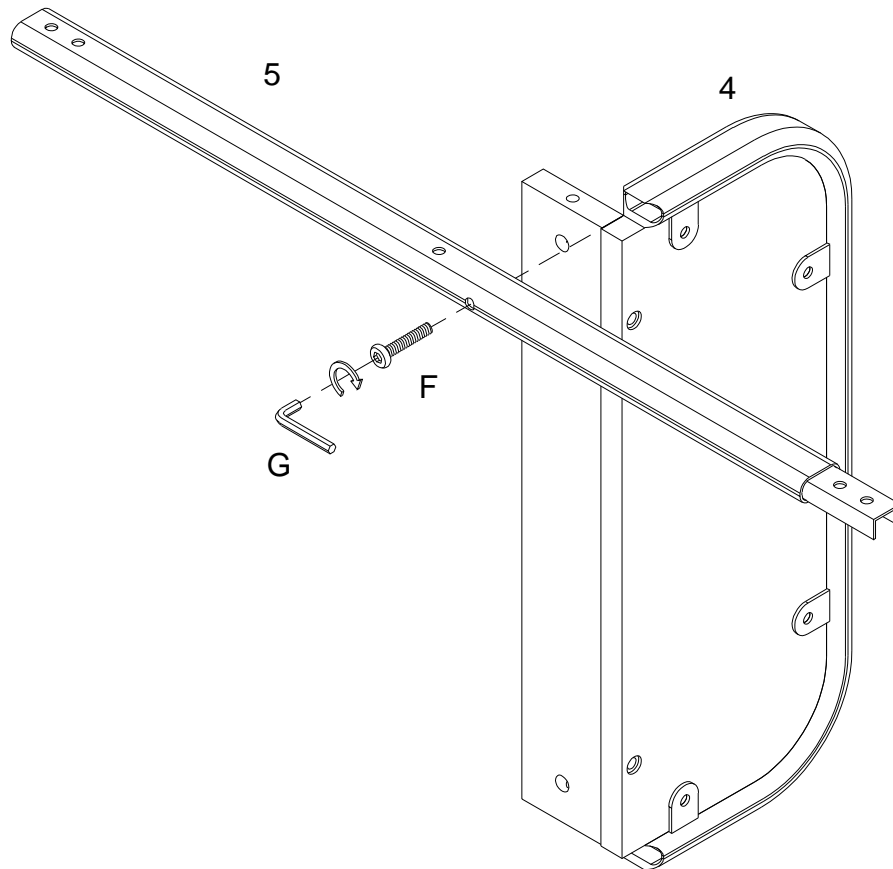

Using Bolt (F) attach part (5) to part (4) with Hex key (G) as per diagram.

Note: Please do not fully tighten all bolts .

Step 5

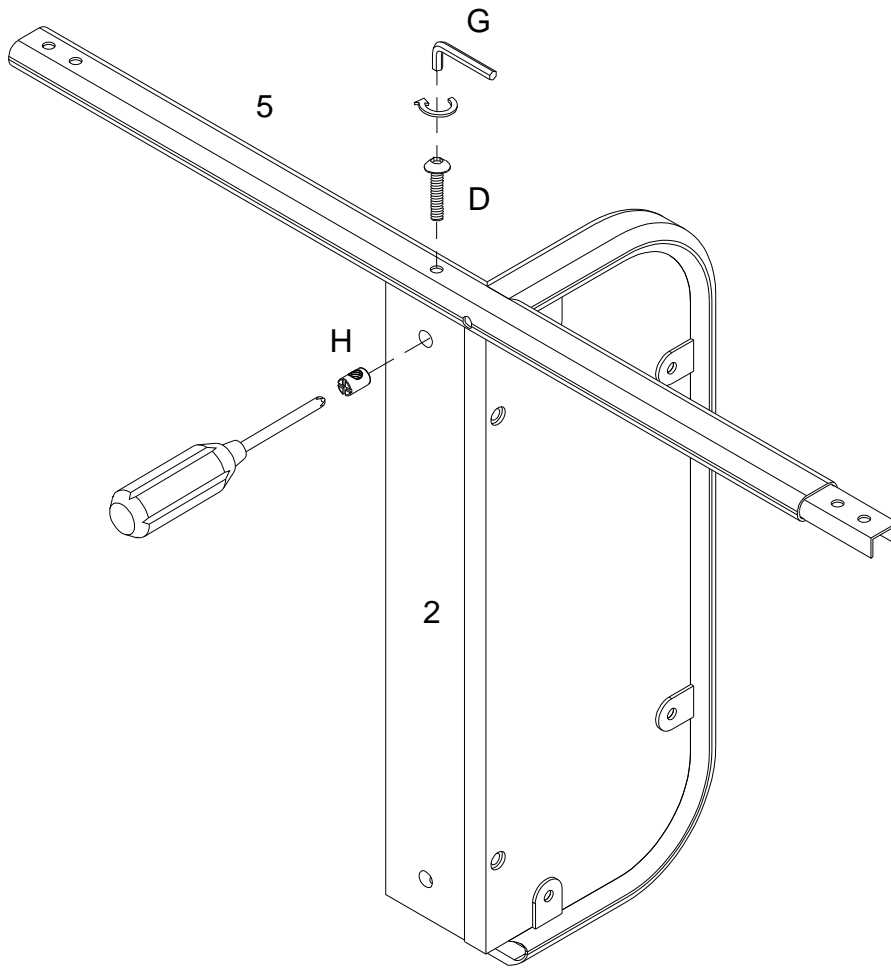

Secure Nut (H) into part (2) with Philips head screwdriver , then using bolt (D) attach part (5) to part (2) with Hex key (G) as per diagram.

Step 6

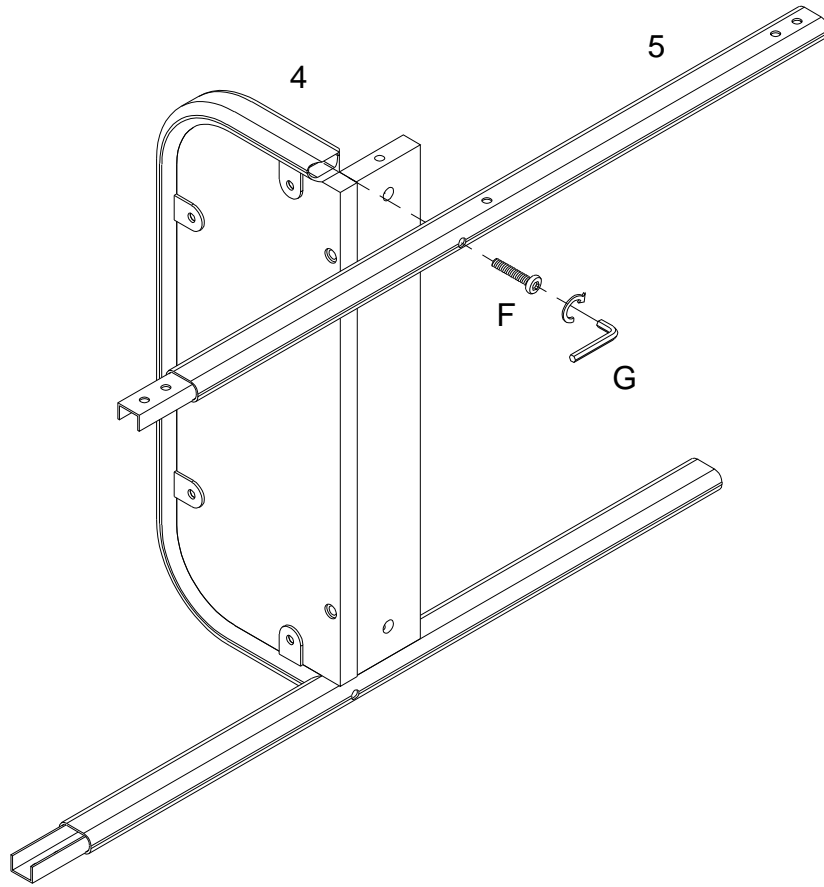

using Bolt (F) attach part (5) to part (4) with Hex key (G) as per diagram.

Step 7

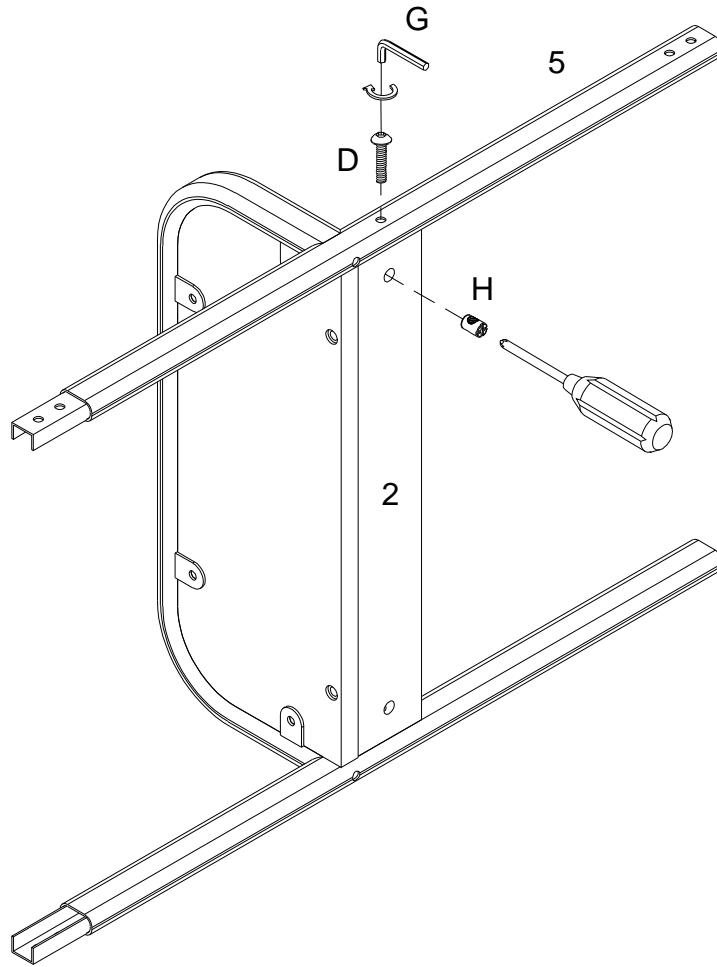

Secure Nut (H) into part (2) with Philips head screwdriver , then using bolt (D) attach part (5) to part (2) with Hex key (G) as per diagram.

Step 8

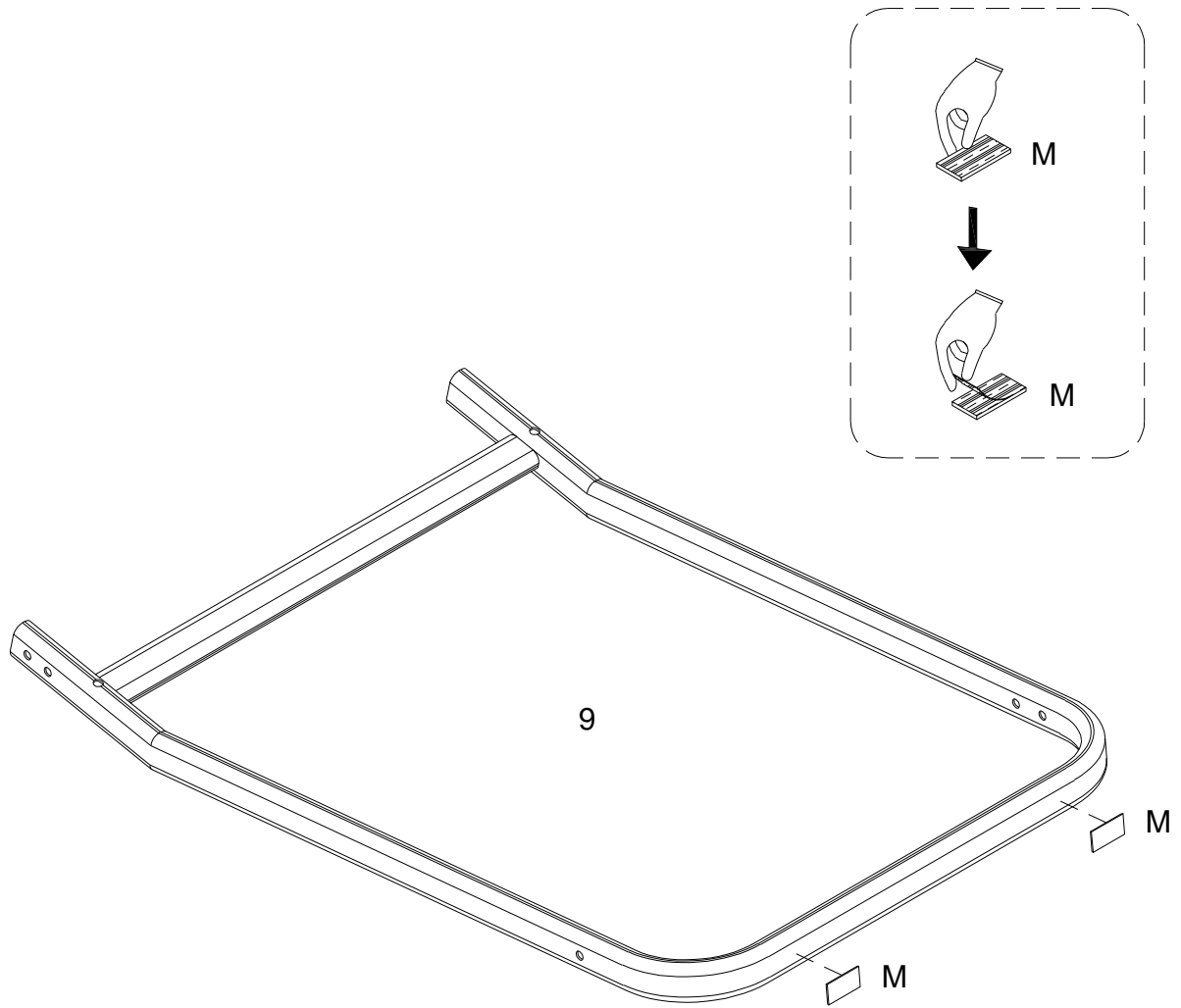

Tear off the EVA pad (M) and place the pad on part (9) as per diagram.

Step 9

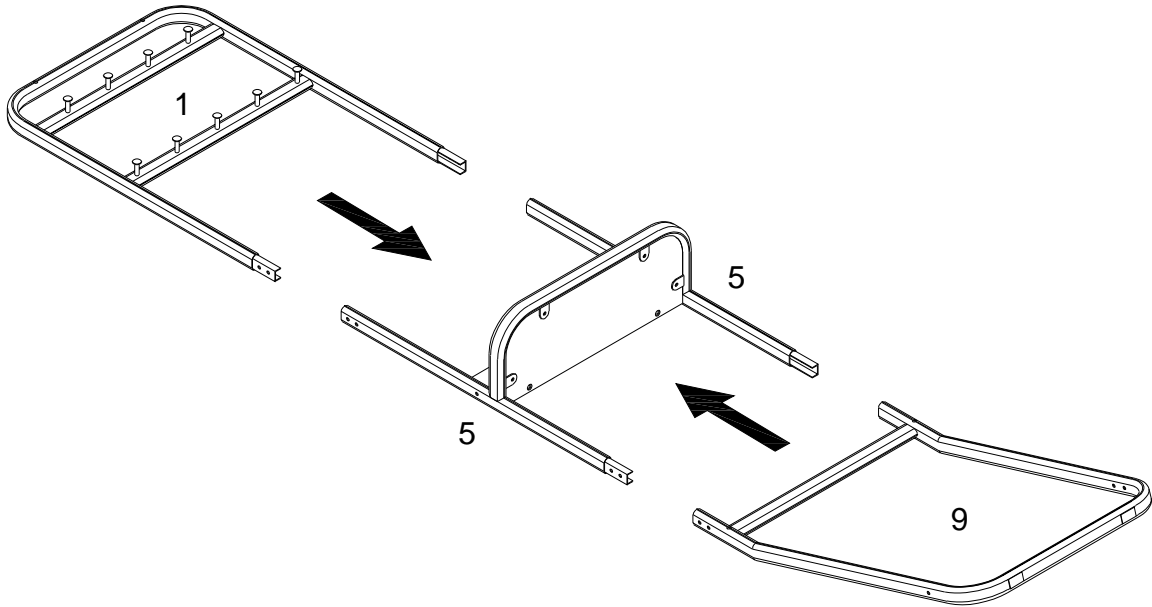

Attach parts(1,9) to part (5) as per diagram.

Step 10

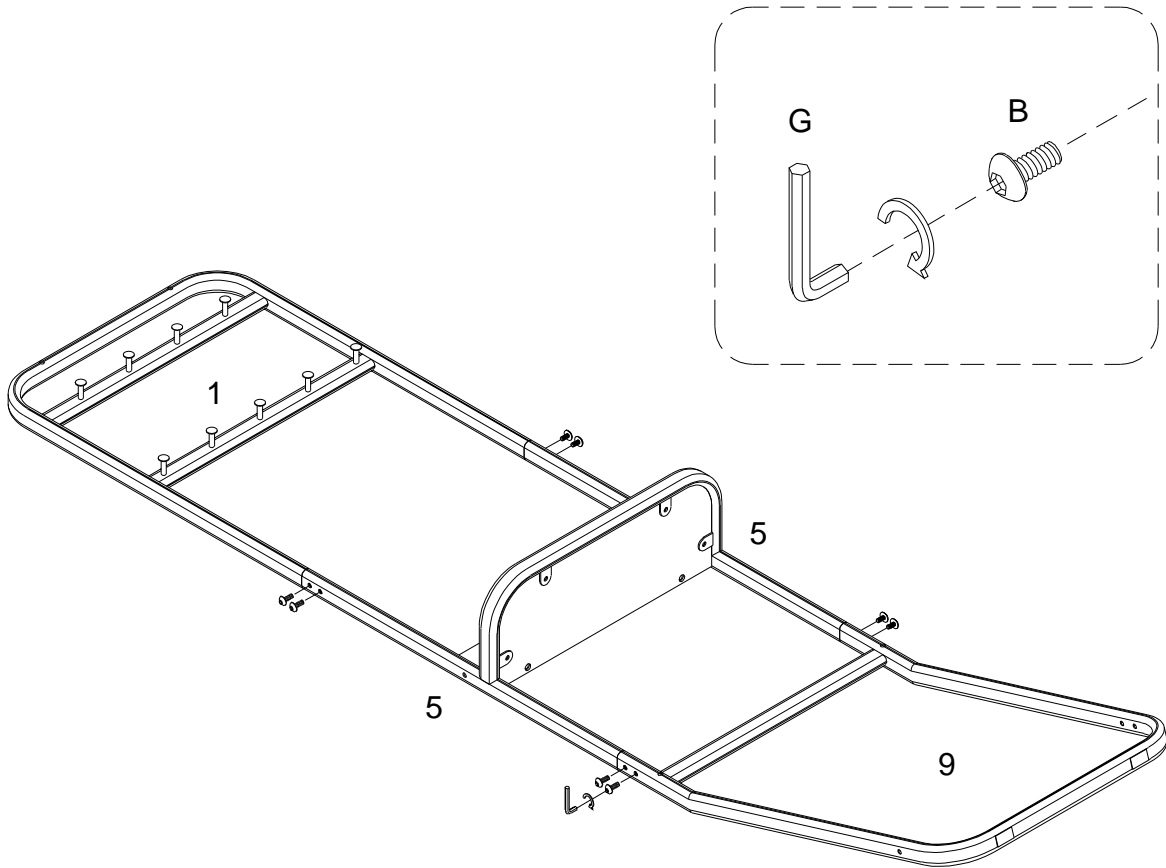

Using bolt (B) attach parts (1,9) to part (5) with Hex key (G) as per diagram.

Step 11

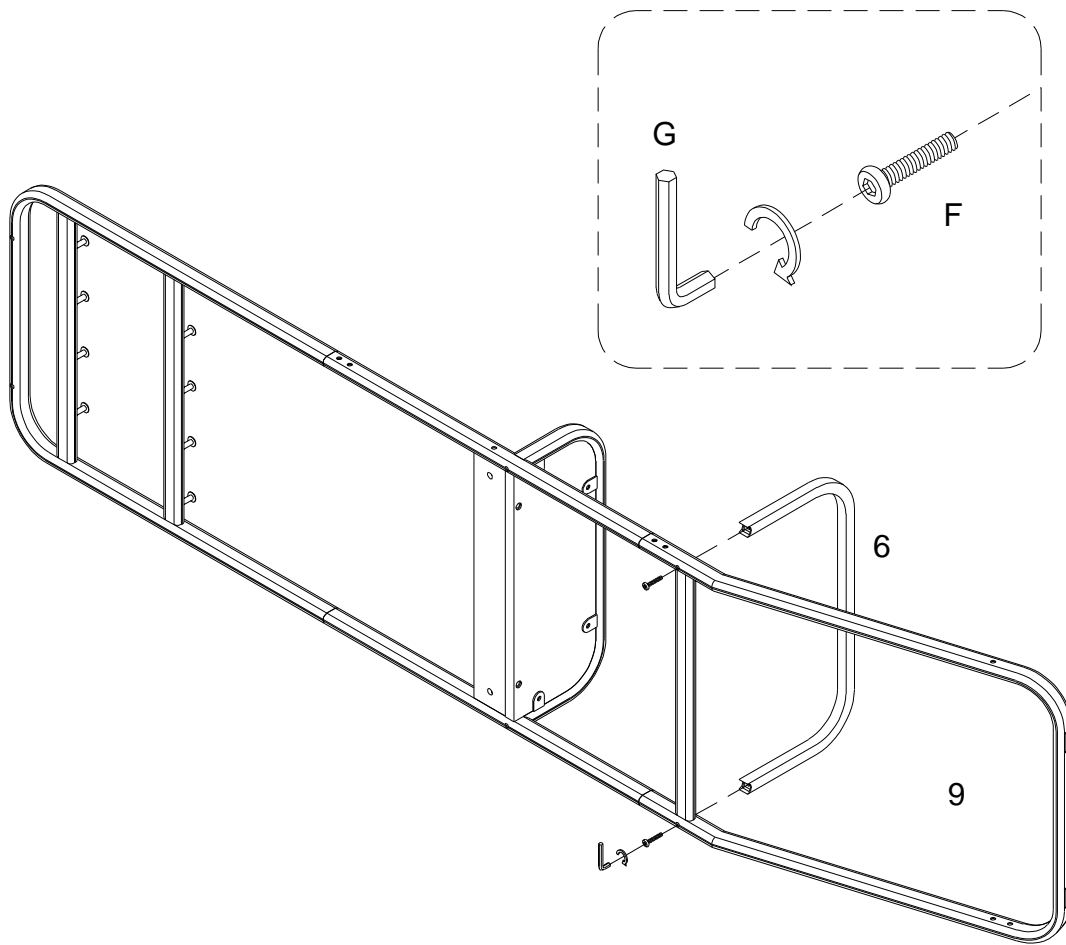

Using bolt (F) attach part (9) to part (6) with Hex key (G) as per diagram.

Step 12

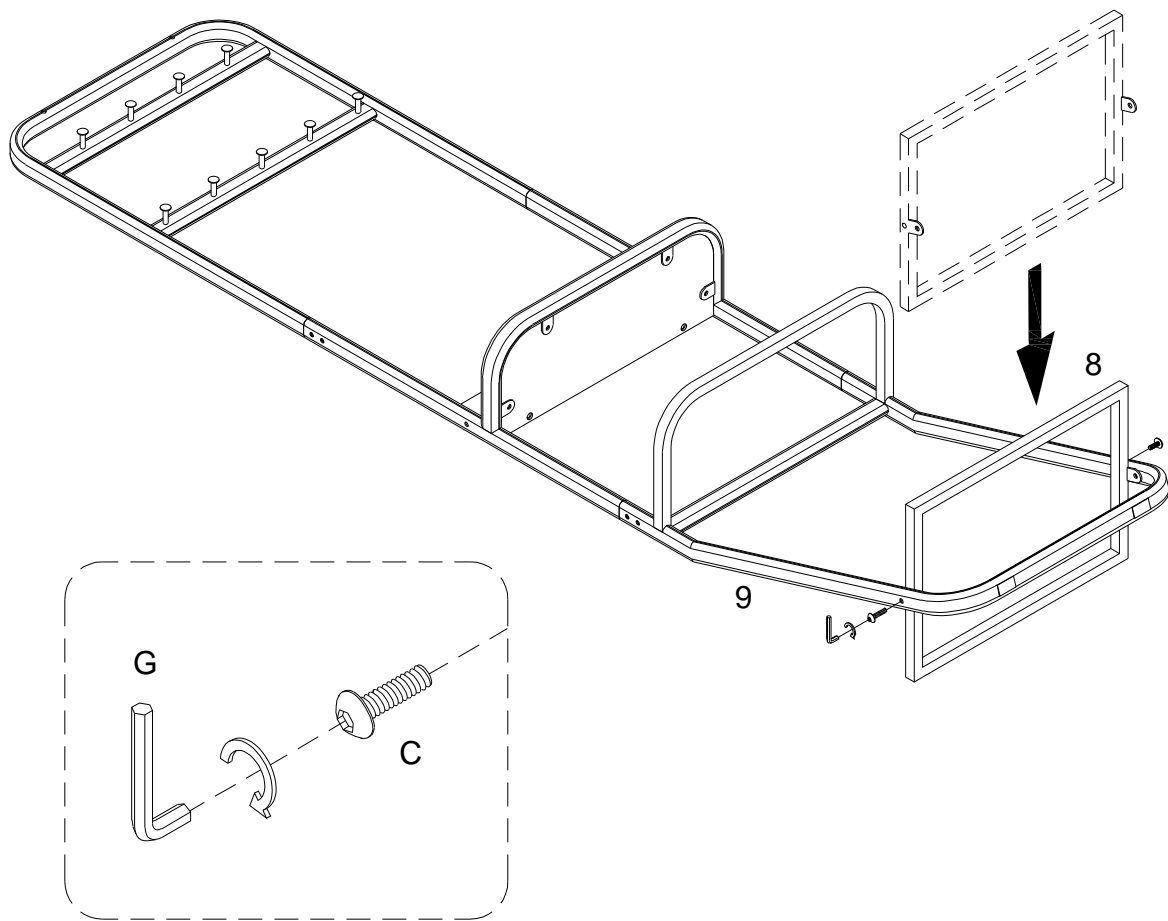

Using bolt (C) attach part (9) to part (8) with Hex key (G) as per diagram.
Note: Do not fully tighten bolts .

Step 13

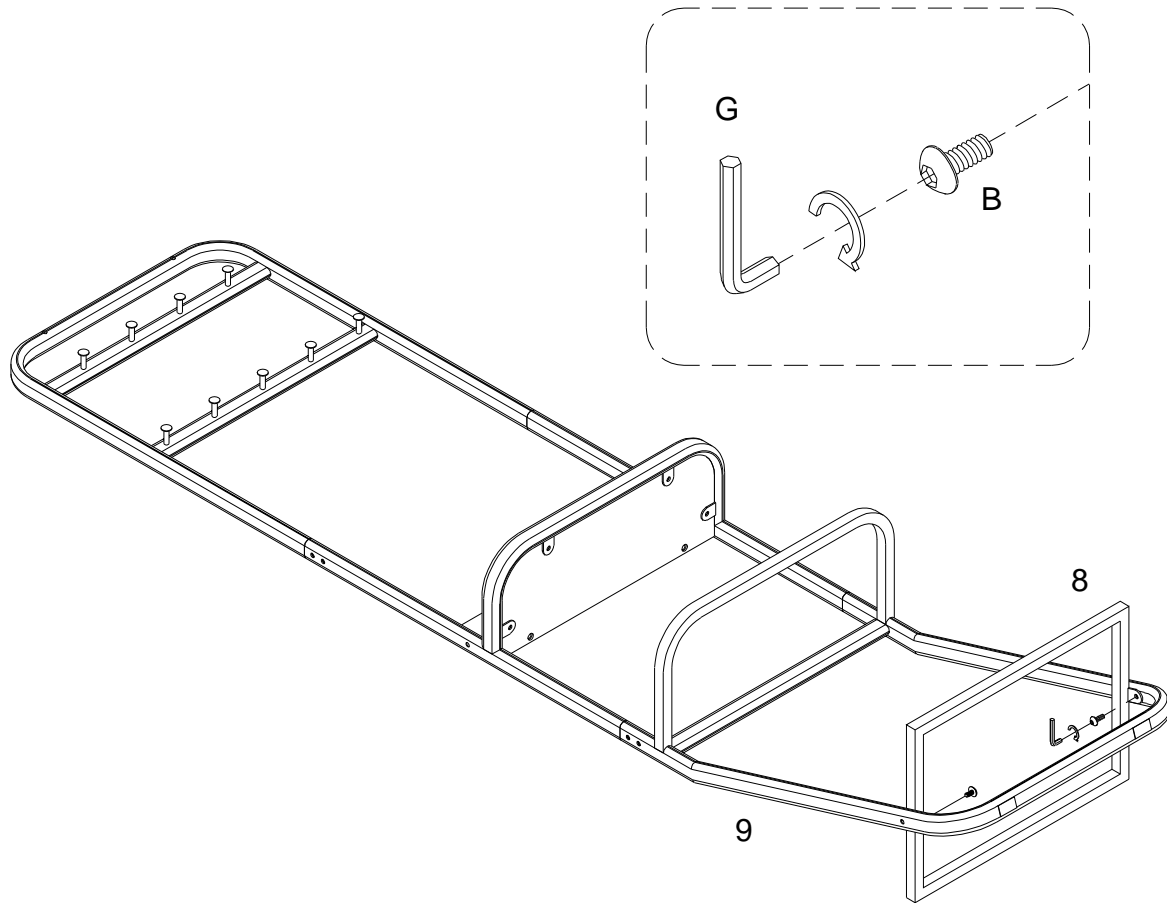

Using bolt (B) attach part (8) to part (9) with Hex key (G) as per diagram.
Note: Fully tighten all bolts.

Step 14

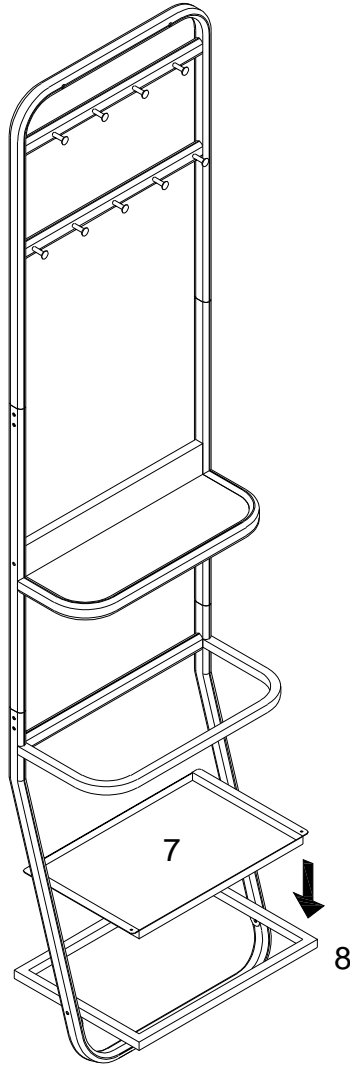

Place the part (7) as per diagram.

Step 15

WARNING

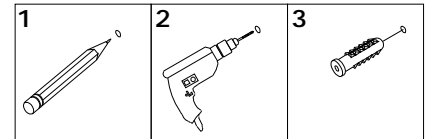

Serious or fatal injuries can occur from furniture tipping over. To prevent the furniture from tipping over we recommend that it is permanently fixed to the wall. Wall anchor and hardware are included with this product. Please make sure hardware is suitable for your walls before installing, as different wall materials may require different types of anchors.

Wall

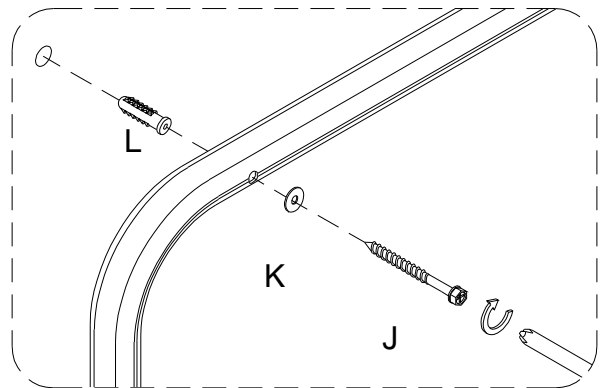
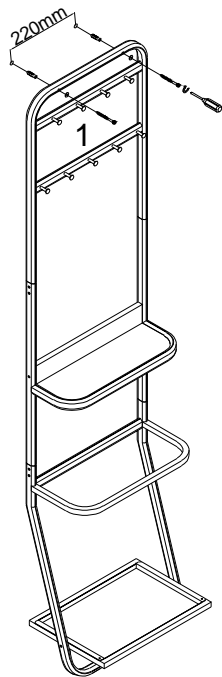

Using screw (J) attach Flat washer (K) into part (1) to nut (L) to wall with Philips head screwdriver as per diagram.

Step 16

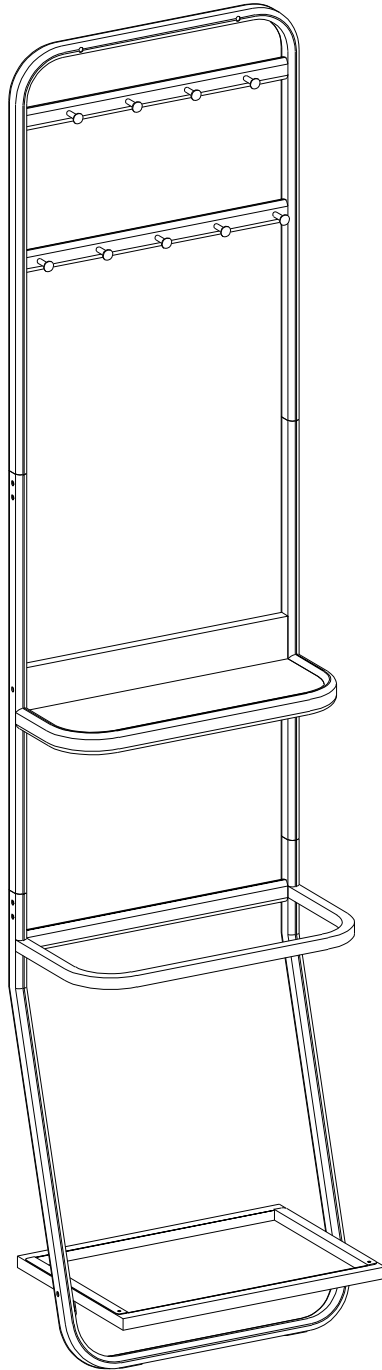

Final Assembly