

- 626-679-3588
- service@getprohome.com
- www.getprohome.com
- 162 Atlantic St, Pomona, CA 91768

INSTALLATION VIDEO

INSTALLATION MANUAL

SHOWER DOOR

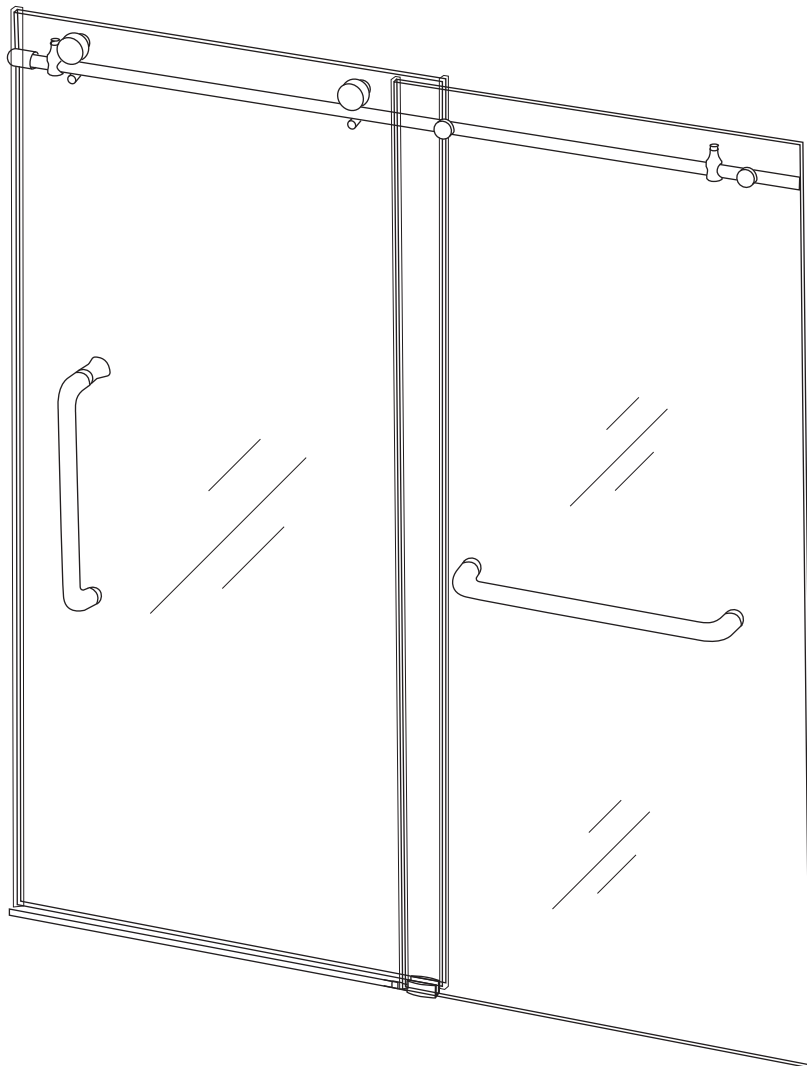

AVAILABLE SIZES

Color Options: Brushed Nickel / Matte Black
Brushed Gold / Chrome

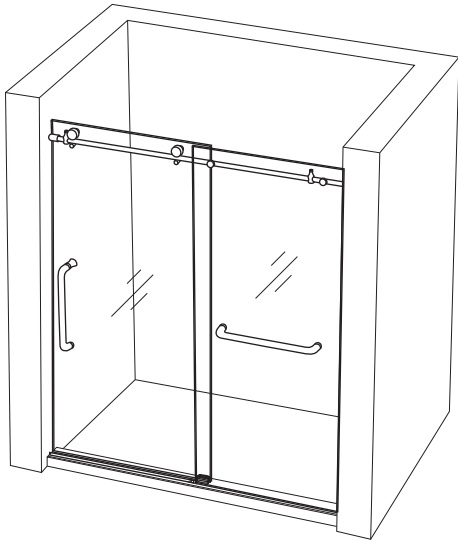

60" W x 75" H

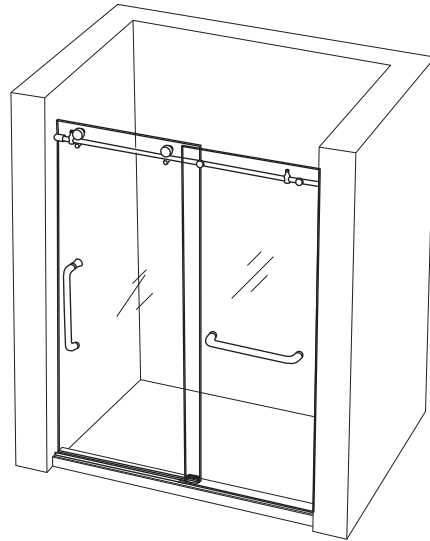

54" W x 75" H

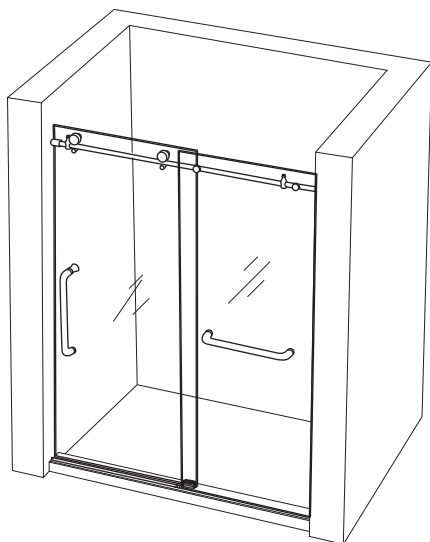

48" W x 75" H

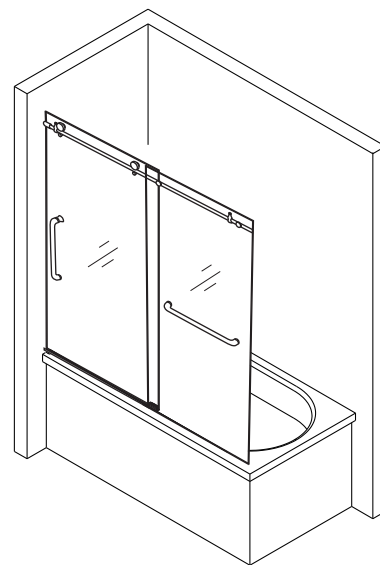

60" W x 60" H

THANK YOU!

Dear Valued Customer,

Thanks to your kind support of BESTGO, we hope our product can improve the quality of your life.

As our valued customer, your comments and opinions are very important to us. If you have any concerns, questions, or comments, we hope that you will bring them to our attention.

Please keep the carton and packaging materials until your product is completely installed.

Feel free to contact us if you encounter any problems such as missing parts, or product defects during the installation process. We are happy to provide you with the most sincere service.

*Sincerely,
BESTGO Service Team*



Please read all instructions carefully before installation.

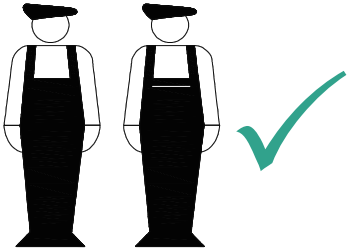

Due to the complexity of the installation process, professional plumbers are recommended.

Required Tools

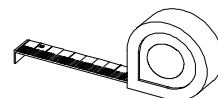
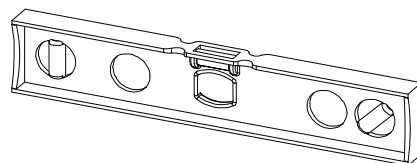
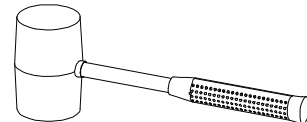
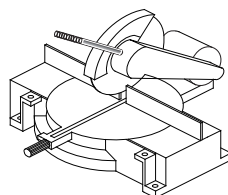
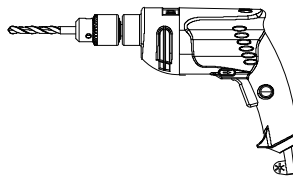
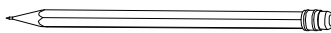
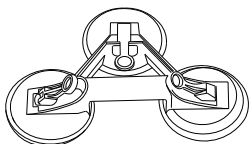
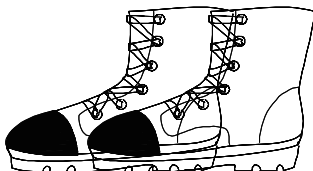
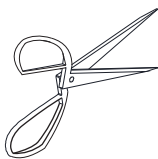
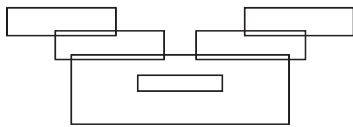

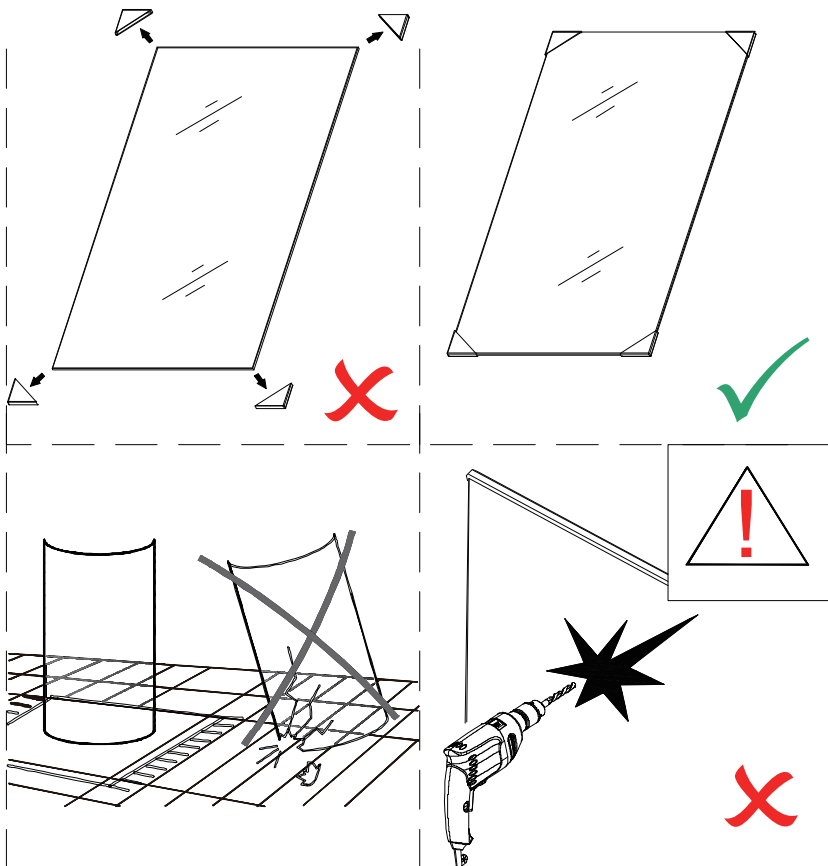
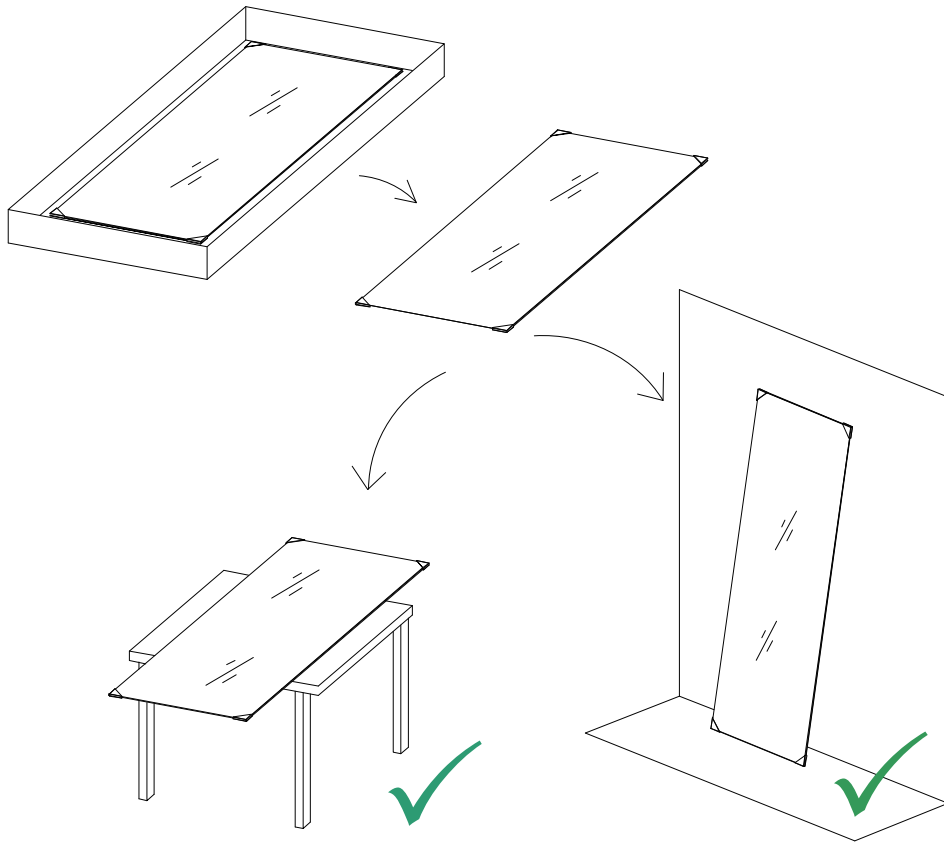



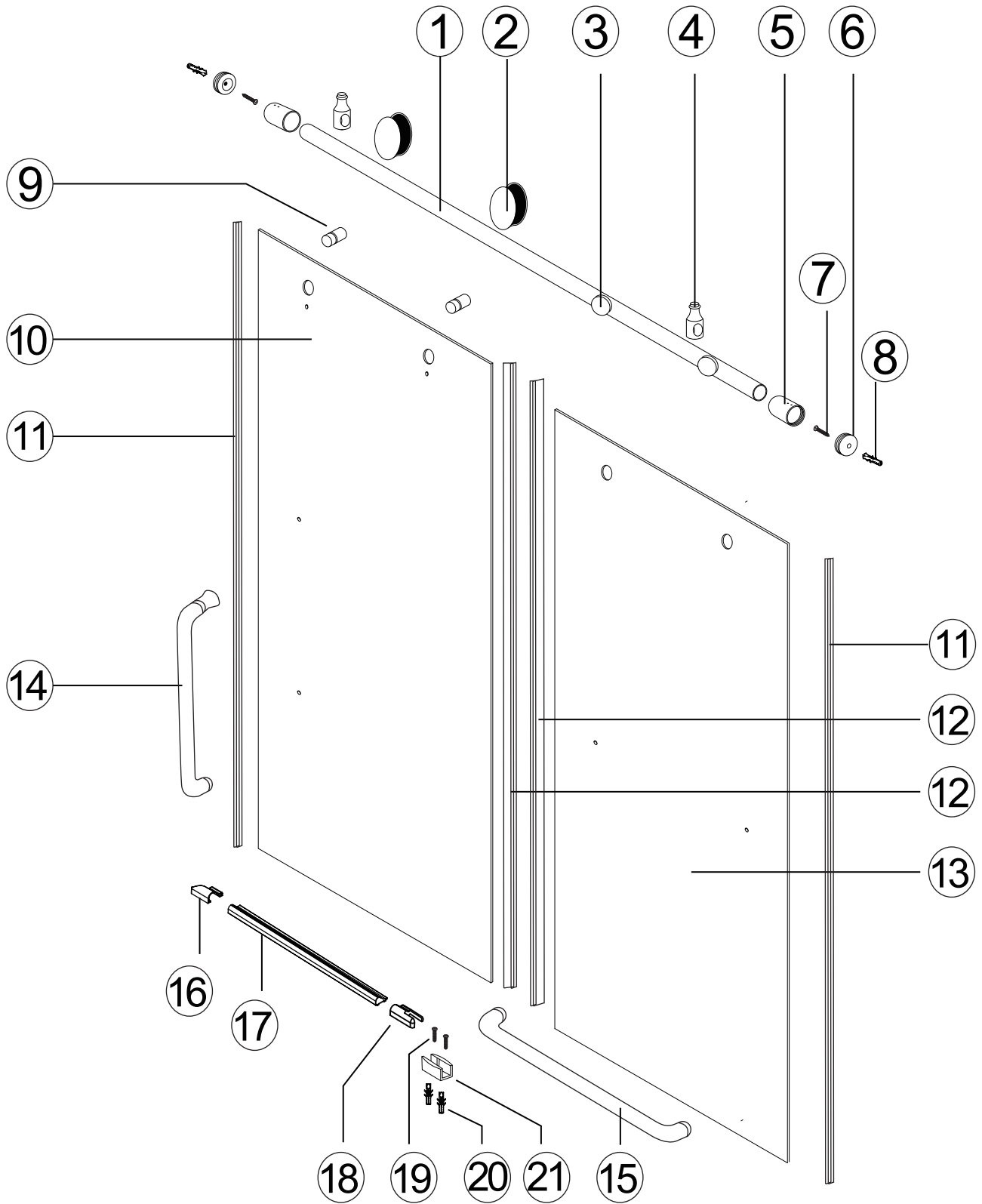











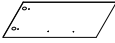

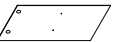
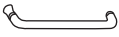
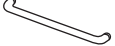



EXPLOSION FIGURE



ACCESSORY TOOLS

No.	Picture	Description	QTY(PC)
①		Upper Guide Rail	1
②		Roller	2
③		Stationary Glass Bracket	2
④		Glass Door Stopper	2
⑤		Support Rod	2
⑥		Rail Bracket	2
⑦		Screw M4.6X40	2
⑧		Wall Anchor	2
⑨		Anti Jumping Knob	2
⑩		Sliding Glass	1
⑪		Anti-Water H Strip	2
⑫		Anti-Water F Strip	2
⑬		Stationary Glass	1
⑭		Grab Bar Handle	1
⑮		Handle	1
⑯		Anti-splash Threshold Cover	1
⑰		Anti-splash Threshold	1
⑱		Anti-splash Threshold U Cover	1
⑲		Screw M4X25	2
⑳		Small Wall Anchor	2
㉑		Guide Block	1
㉒		Measuring Tool (No installation required): Only use to mark the height of rail brackets	㉓  ㉔  ㉕ 

Step 1



Check the level of the wall and base.

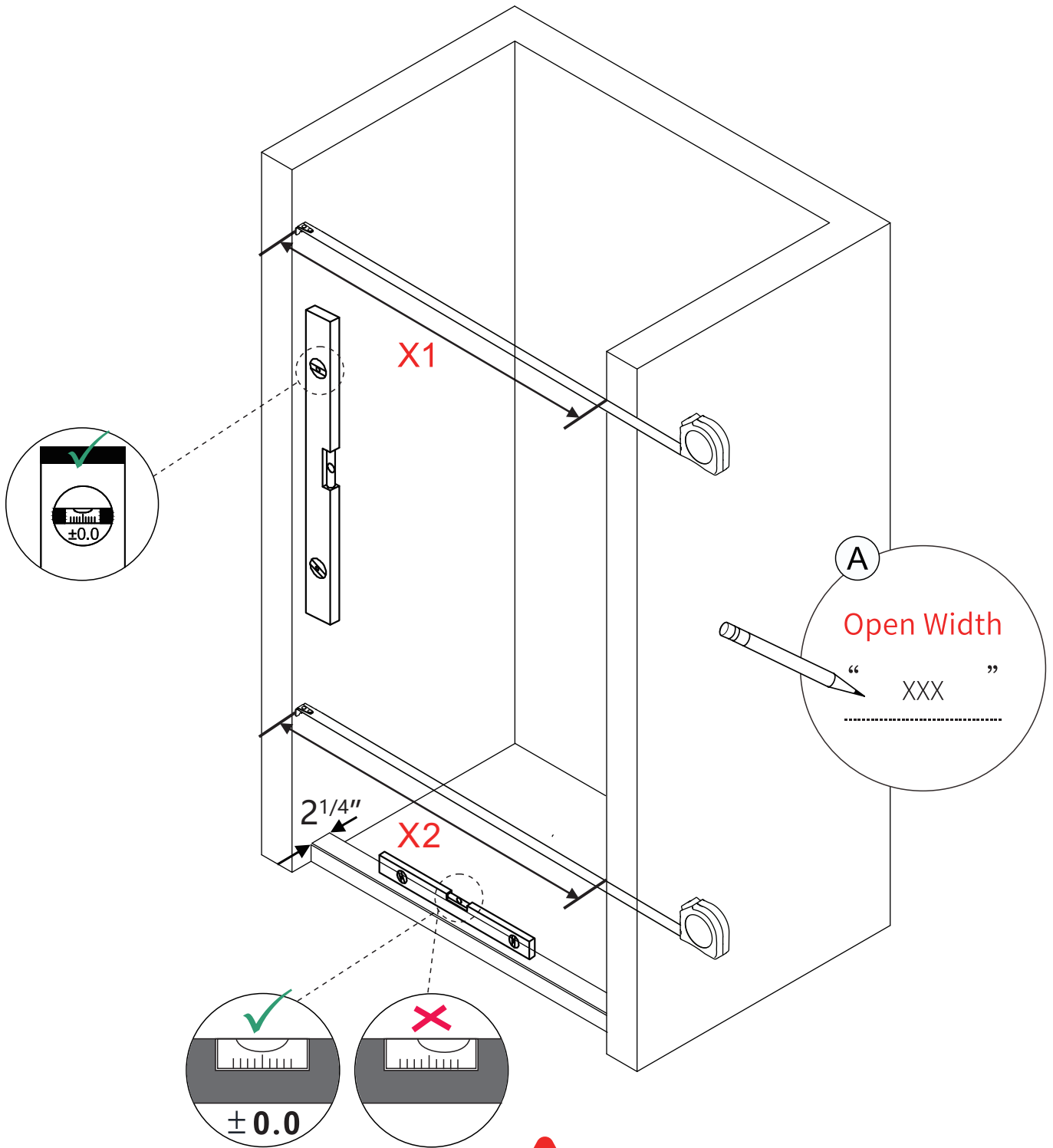

$$X1 = X2$$



Measure the Width of X1 and X2 Carefully, make sure the width of the upper and lower walls is consistent before installation.



HOW TO TRIM THE RAIL AND THRESHOLD

Model Size

60" W*75" H / 60" W*60" H

Trim Width = 60" - Open Width

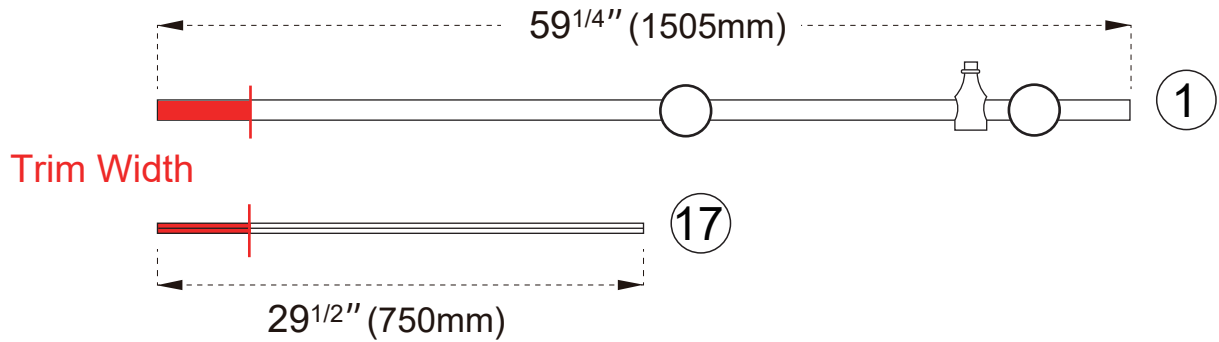

Model Size

54" W*75" H

Trim Width = 54" - Open Width

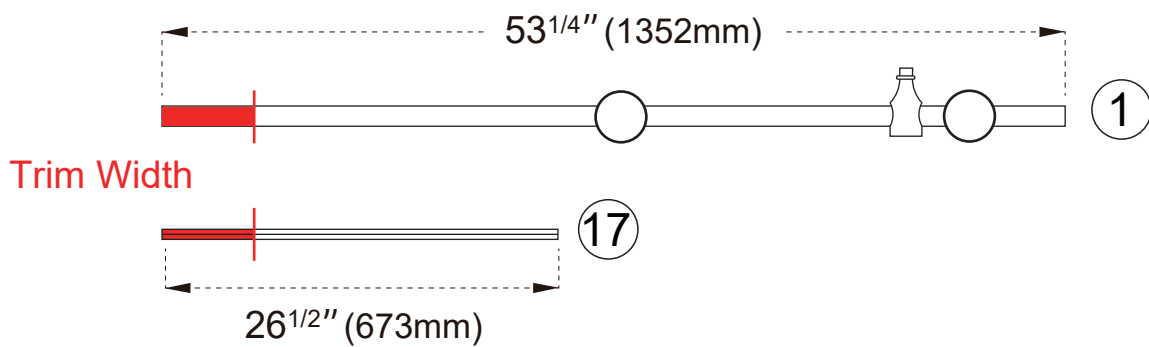

Model Size

48" W*75" H

Trim Width = 48" - Open Width

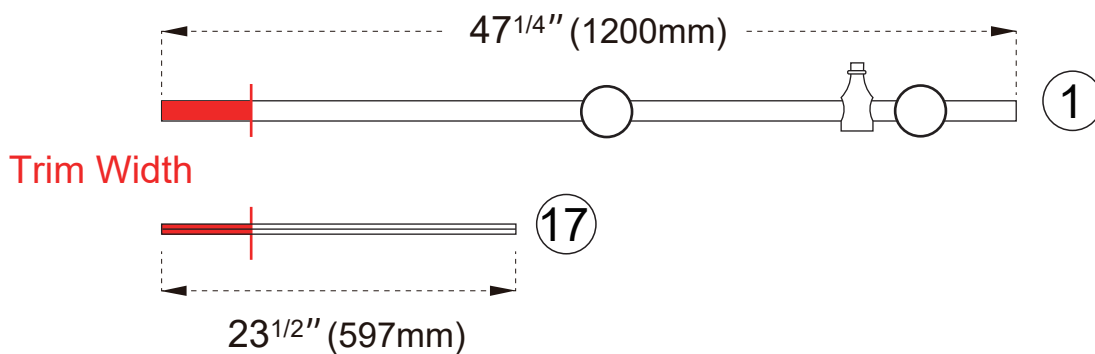

Step 2



- Only trim the end of the Upper Guide Rail (1) without hole.
- The Max. trim width is less than 4 inches.

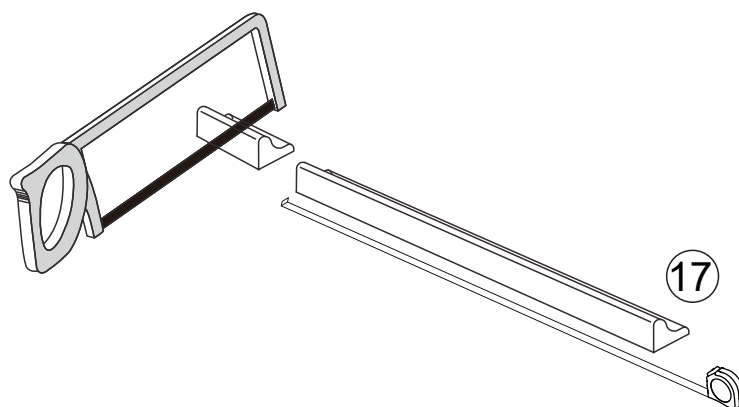
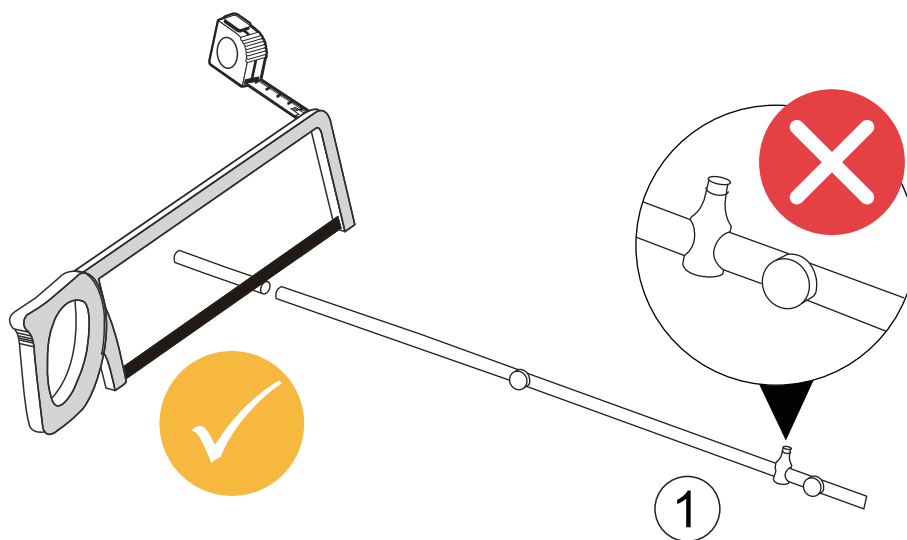
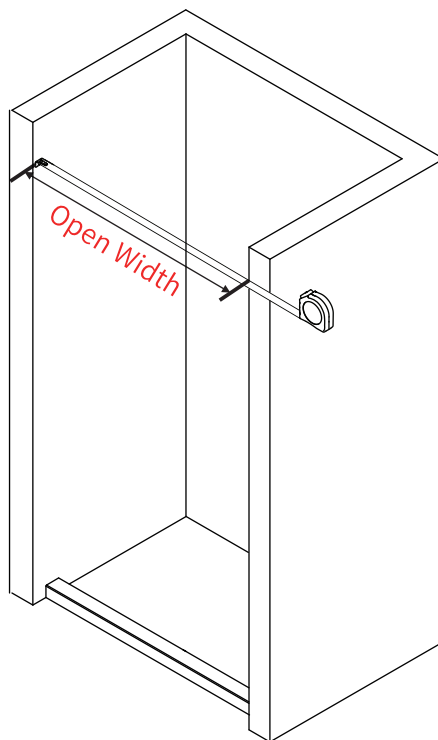

Step 3

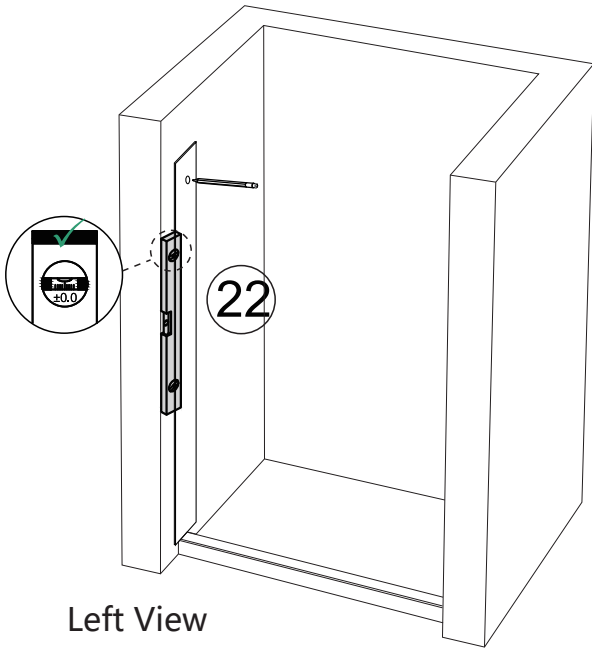

Left View

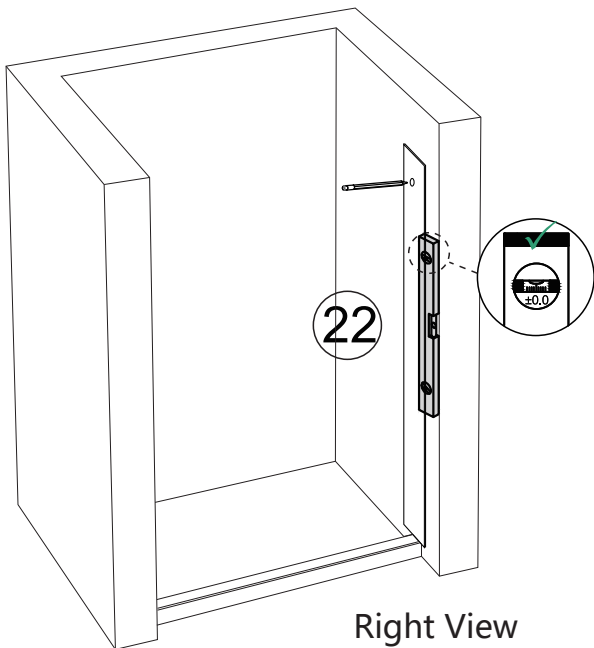

Right View

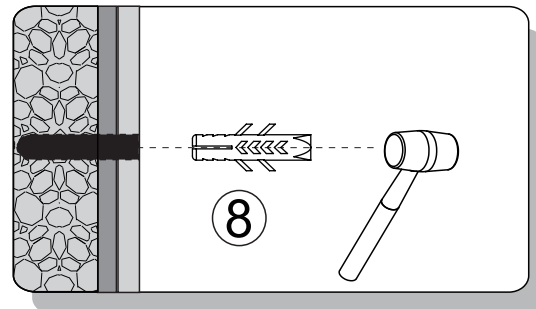
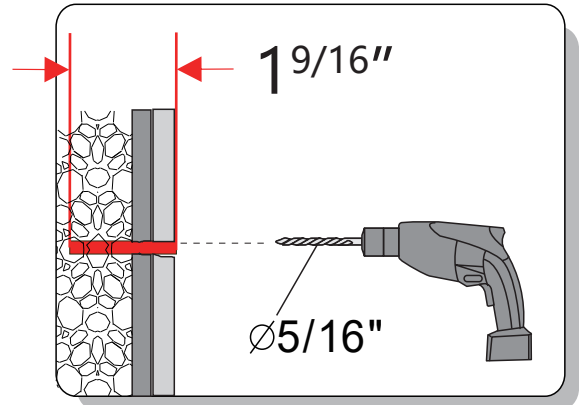
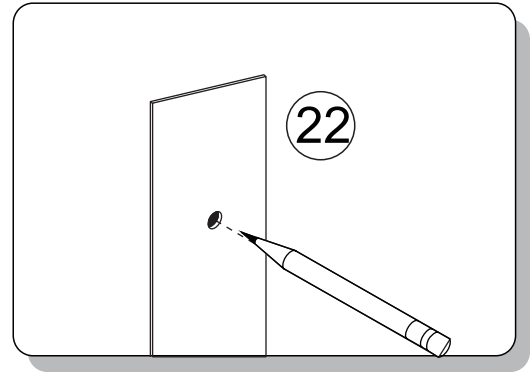

Model Size	Height of Mounting Rail Bracket
60"W * 60"H	57 ⁷ / ₁₆ " (1459mm)
60"W * 75"H 54"W * 75"H 48"W * 75"H	72 ⁷ / ₁₆ " (1840mm)

Place the Measuring Tool(#22) vertically against the wall on the base, Mark the drill points at the specified mounting height according to the holes in the Measuring Tool(#22),drill holes for the Guide Rail Brackets (#6) in the determined position, insert the wall anchors (#8) for the Guide Rail Bracket.

This step uses an Ø 5/16" drill bit to drill holes in the wall.

Step 4

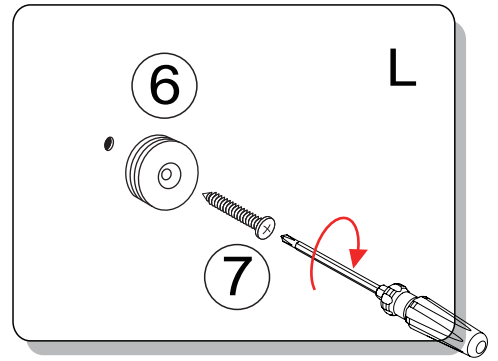
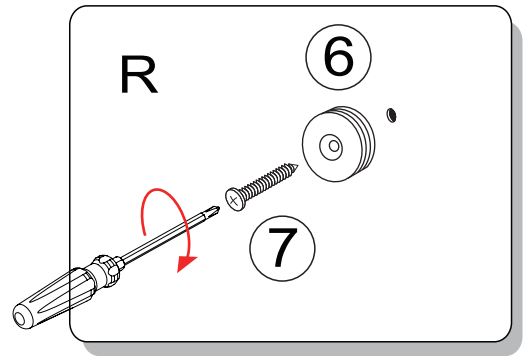
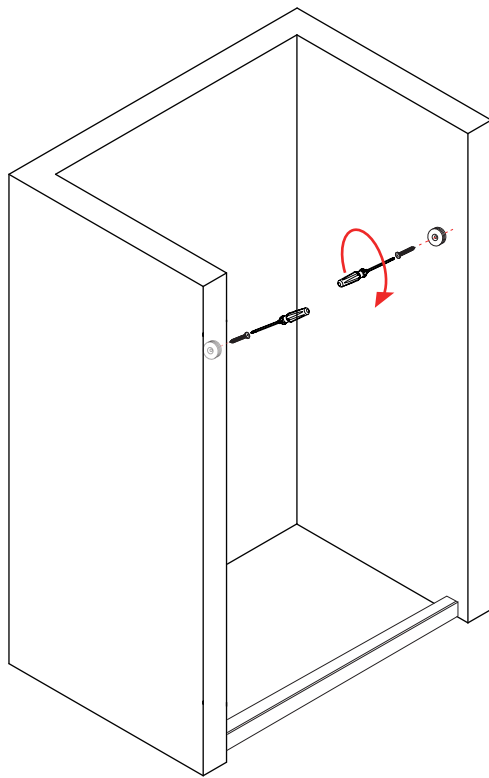

Step 5

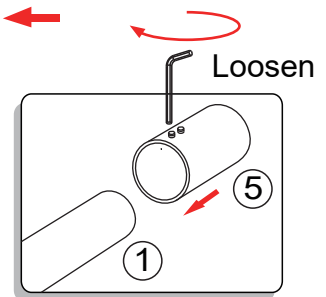
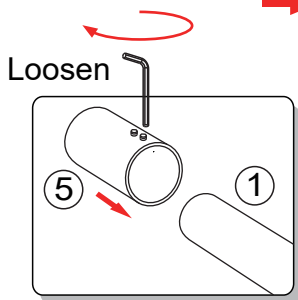
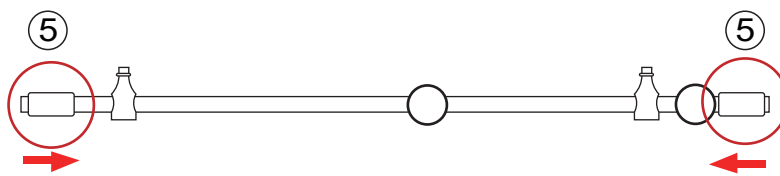
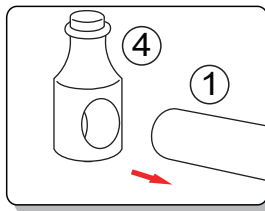
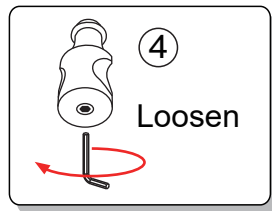
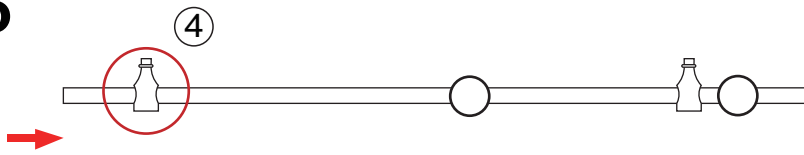

Step 6

 NO NEED to tighten the screws

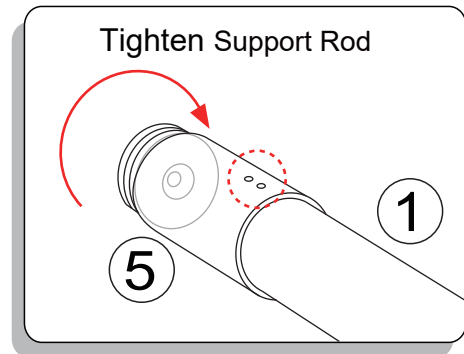
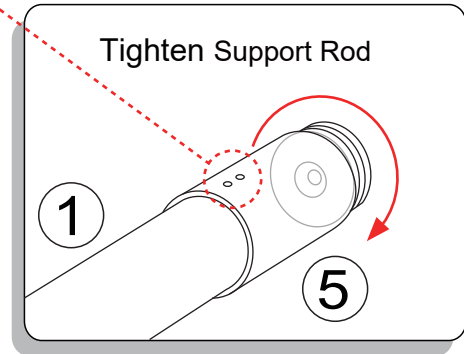
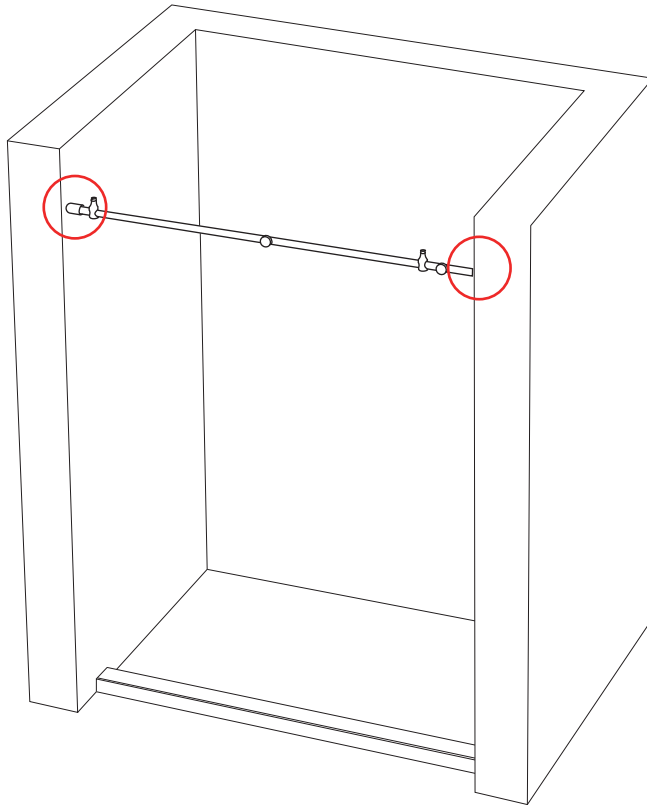

Step 7

Move the sliding glass (10) into shower enclosure and put it on pads to prevent breakage.



- LEFT sliding door, the handle holes toward LEFT
- RIGHT sliding door, the handle holes toward RIGHT

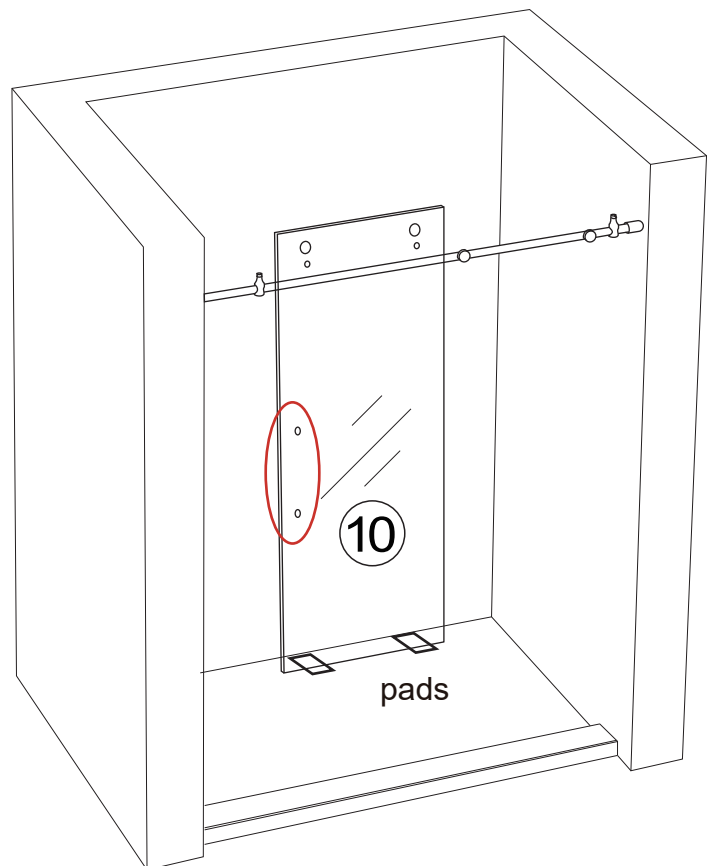

Step 8

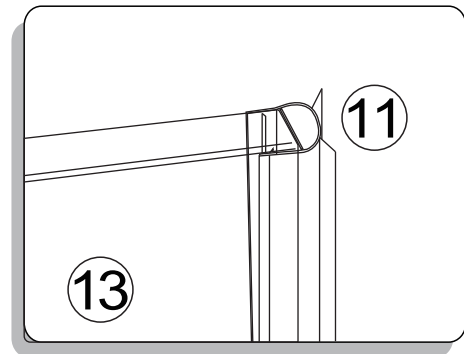
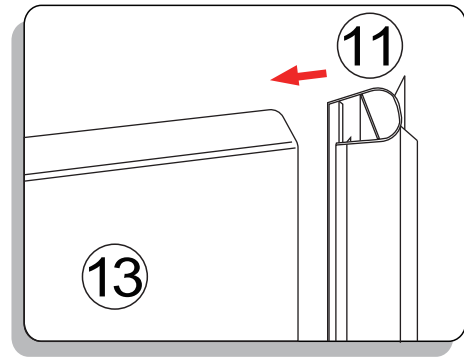
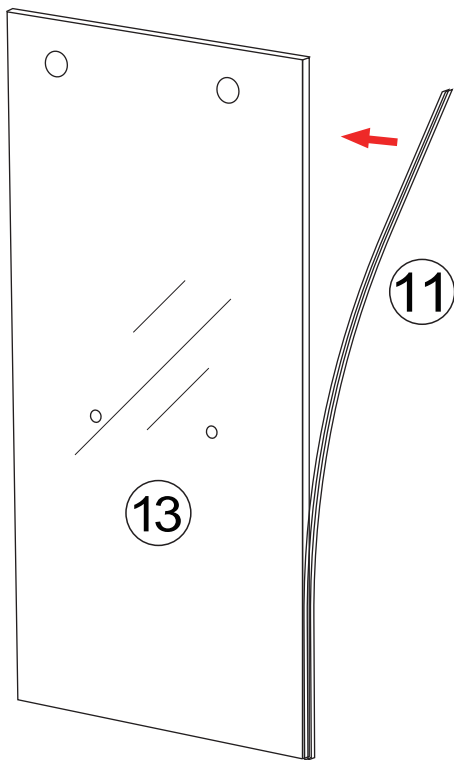

Step 9

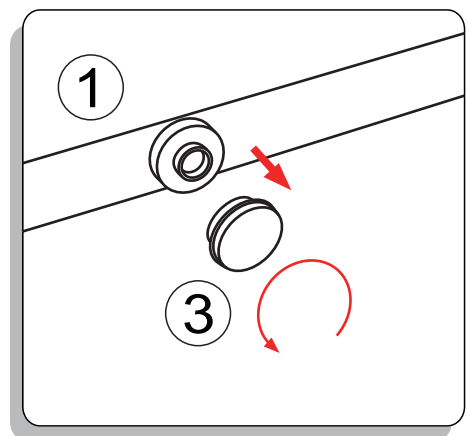
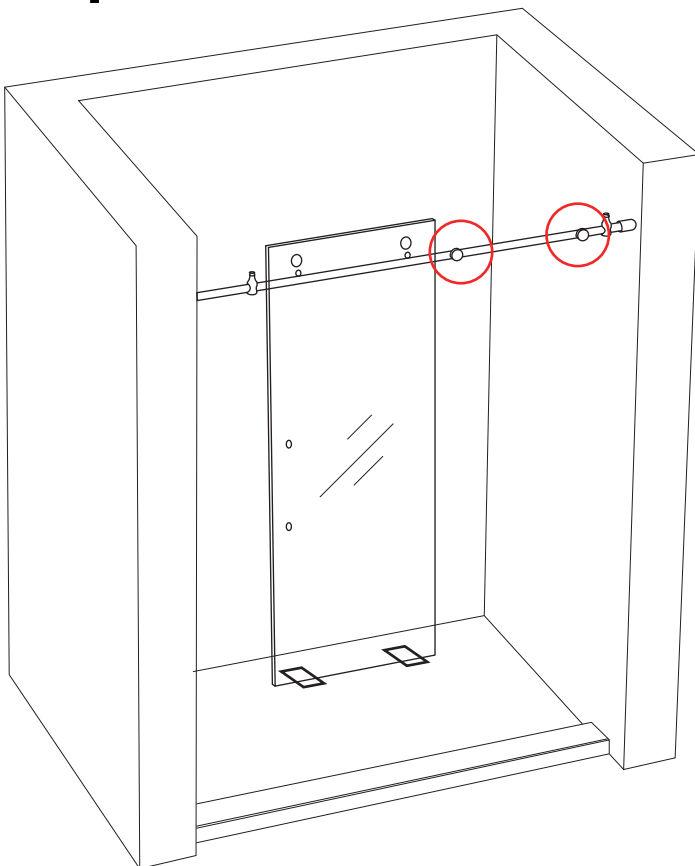

Unscrew the covers

Step 10

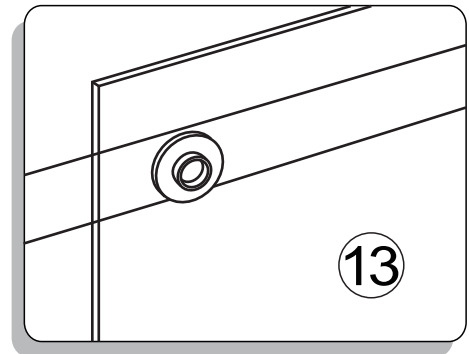
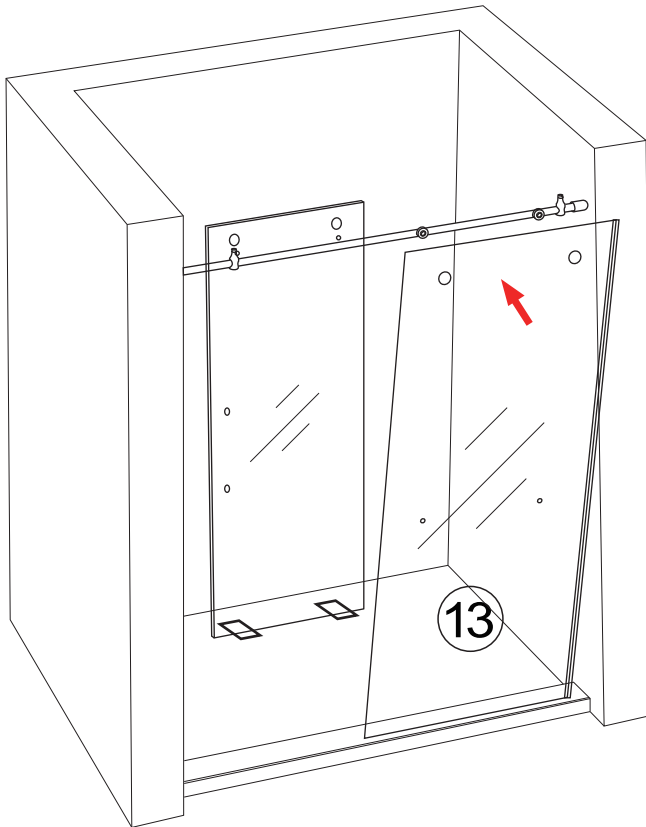

Seat the glass snugly against the wall, adjust the horizontal position and tighten the caps.

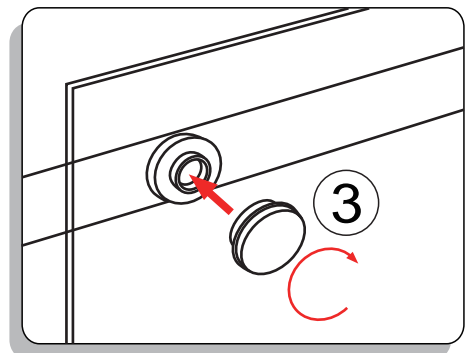
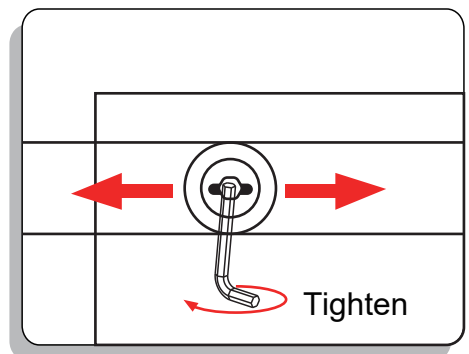
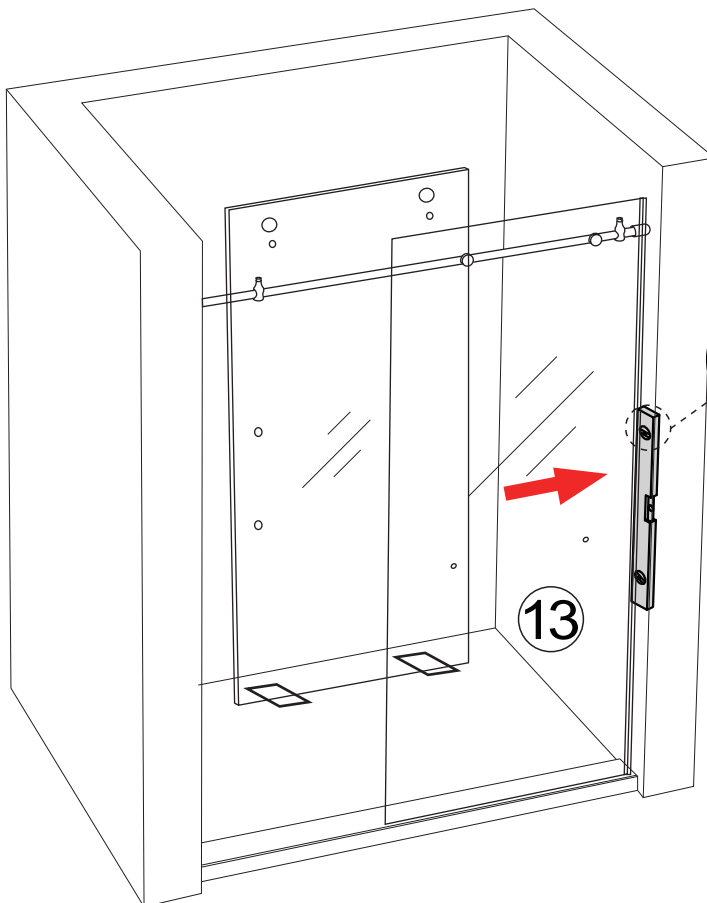

Step 11

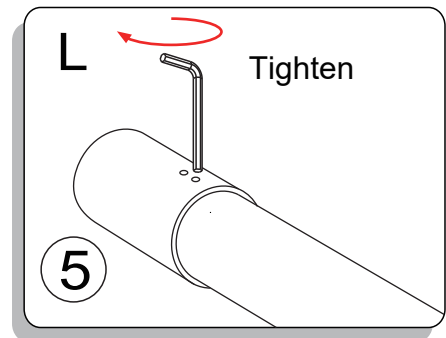
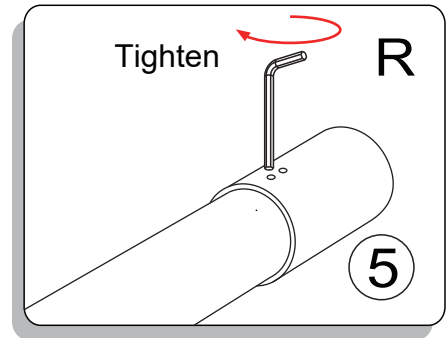
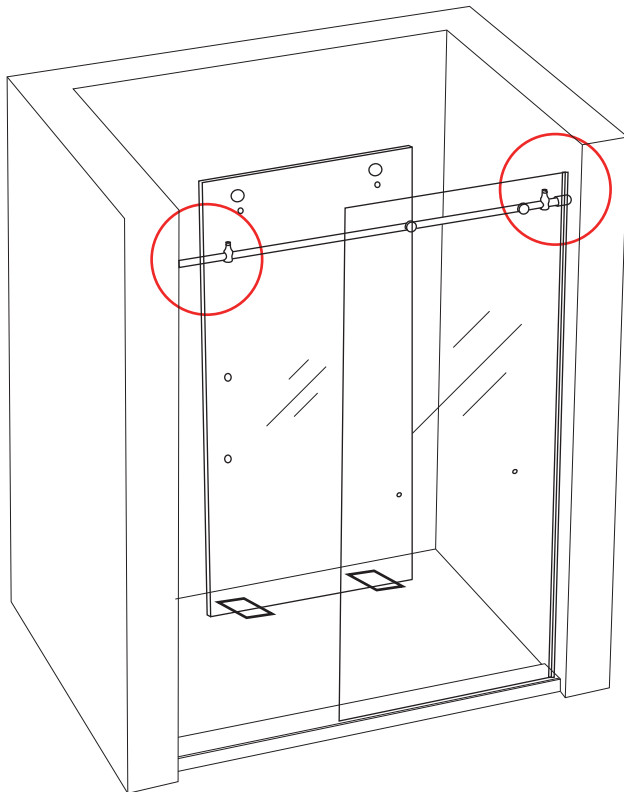

Step 12

Set the roller to sliding glass(10)

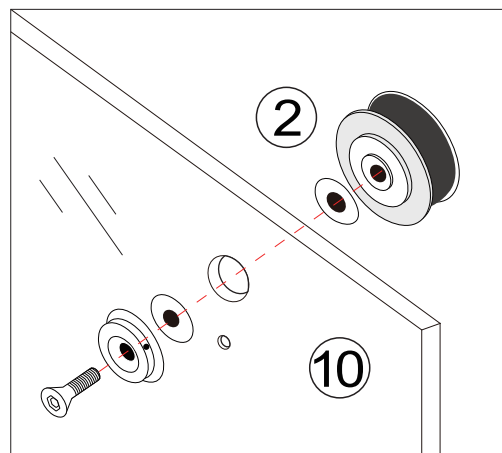
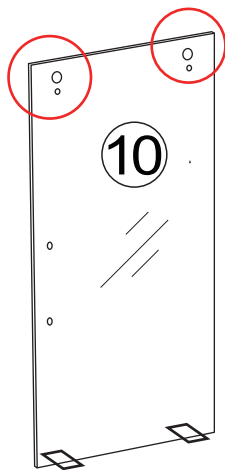

! Don't cover the caps of rollers

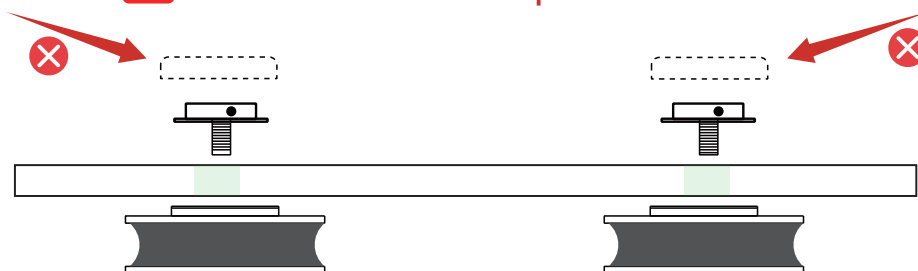

Step 13

Hang the sliding glass (10) back to the Upper Guide Rail (1)

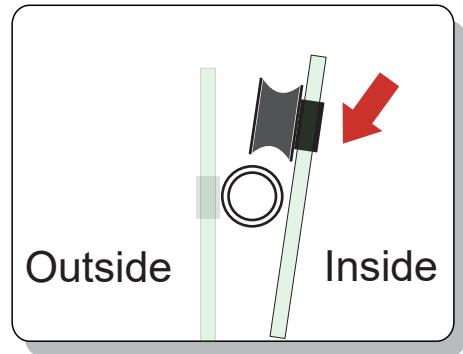
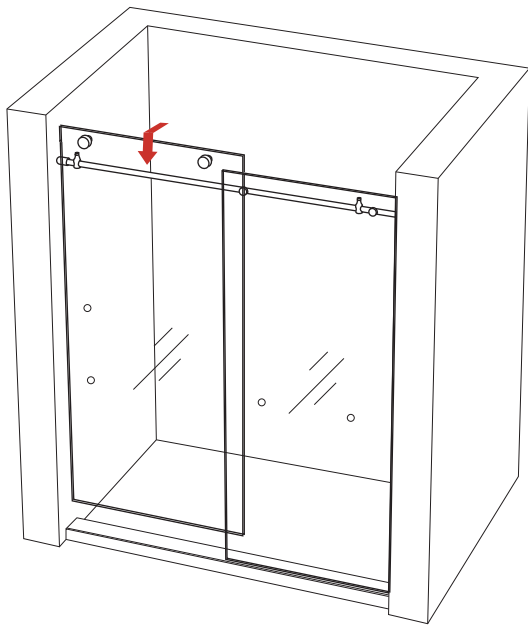

Step 14

Adjust the Vertical and Horizontal

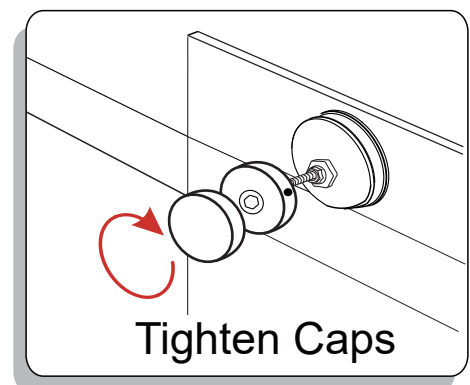
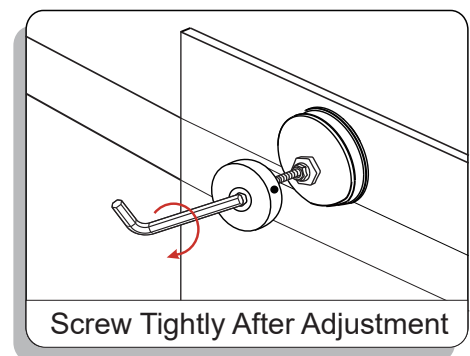
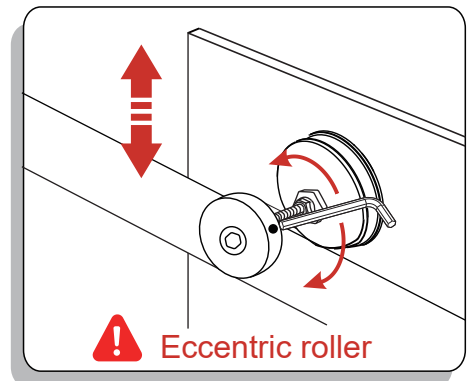
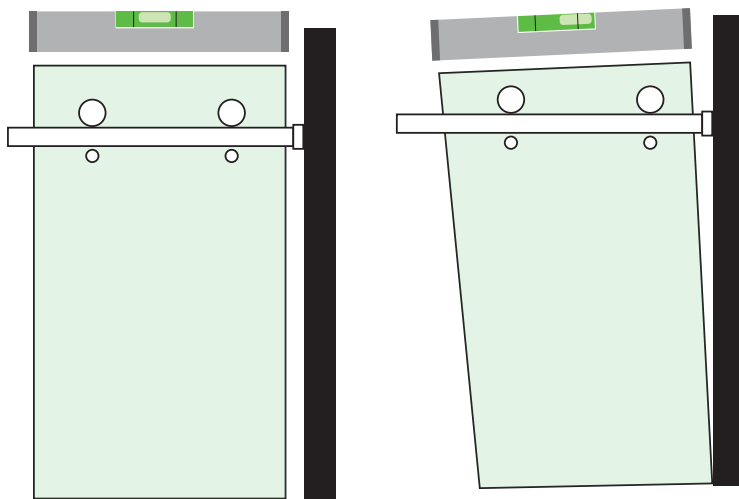

Step 15

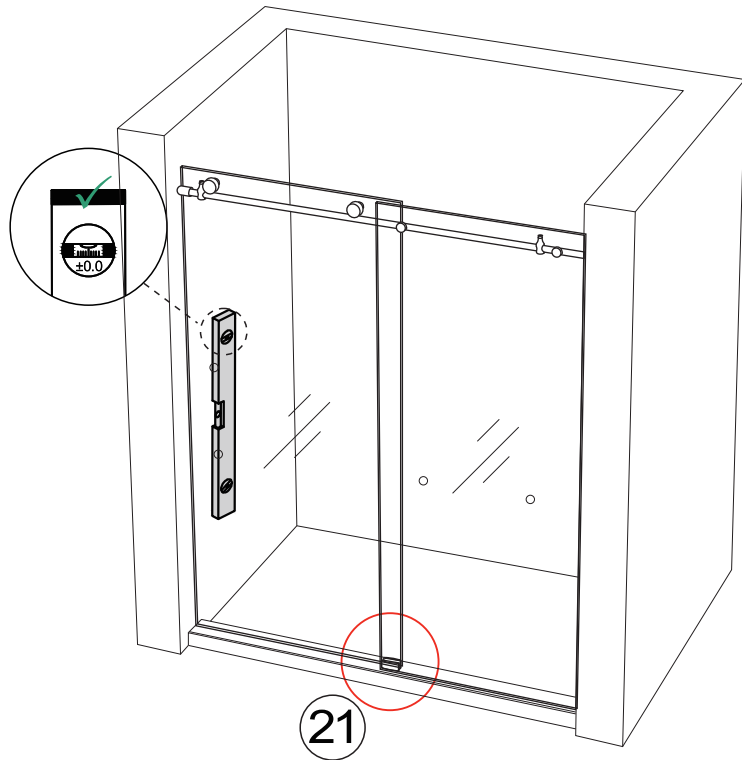
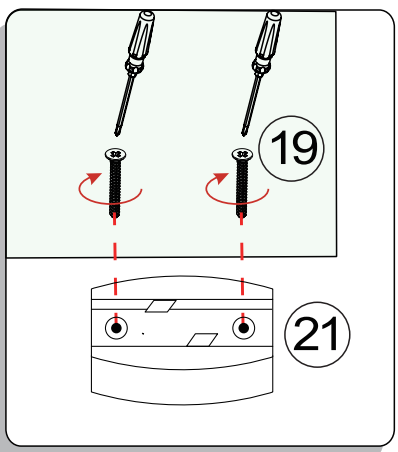
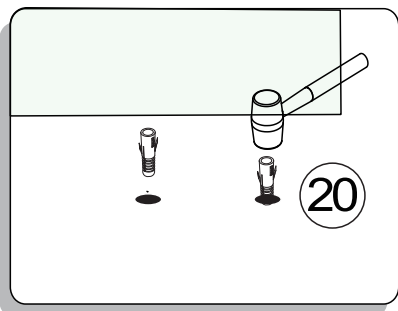
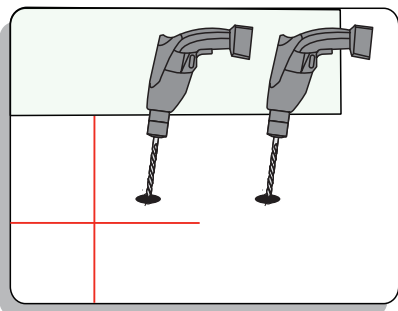
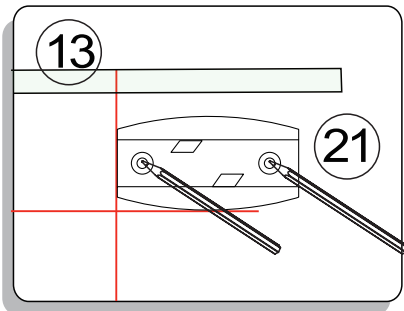
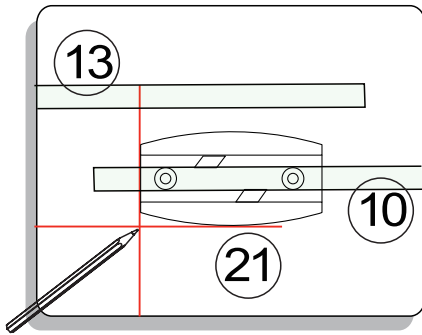

After hang the Sliding Glass (13) to the Upper Guide Rail (1), Slide the Guide Block (21) to the bottom of the Sliding Glass, mark down the predrilled position of the Guide Block, set the Sliding Glass aside. Now drill the holes on the base, then put the wall anchors (20) into the holes and secure the Guide Block to the base with Screws M4X25 (19). Please uses an Ø1/4" drill bit to drill holes.

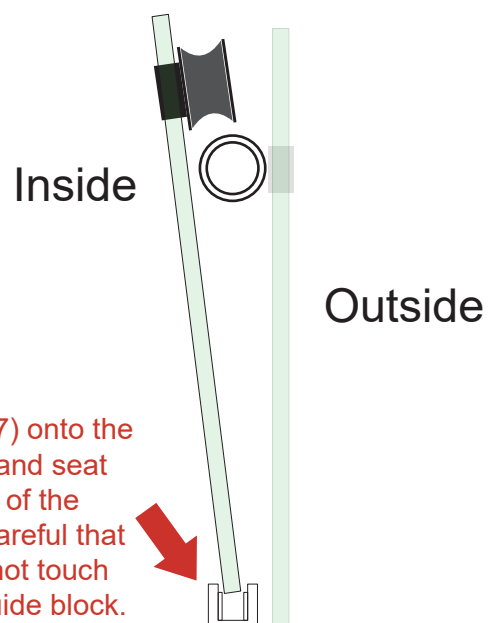

Hang the Glass Door (7) onto the Upper Guide Rail (5), and seat the bottom into the slot of the Guide Block (11). Be careful that the glass door should not touch the metal part of the guide block.

Step 16

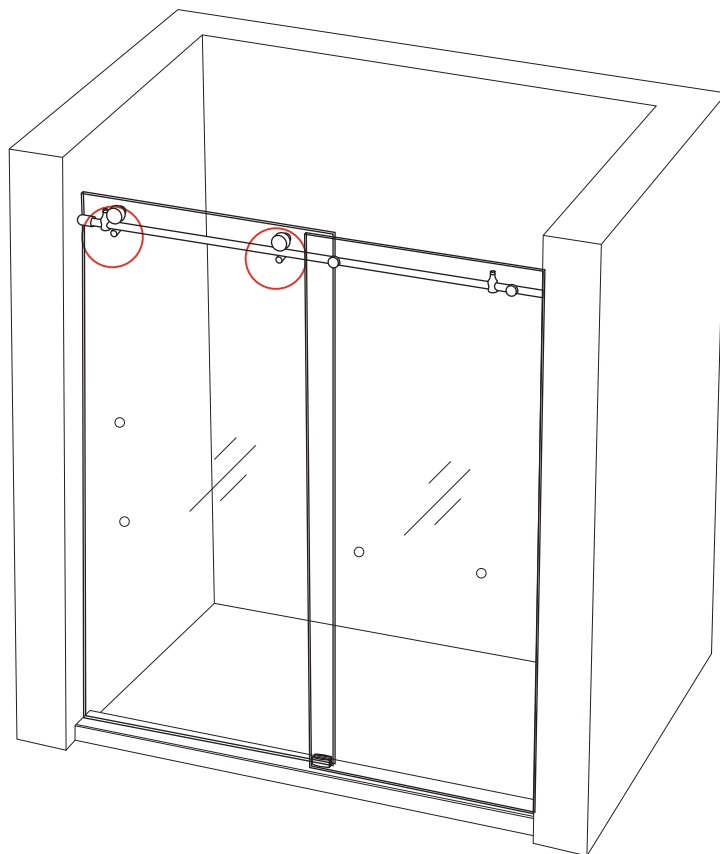
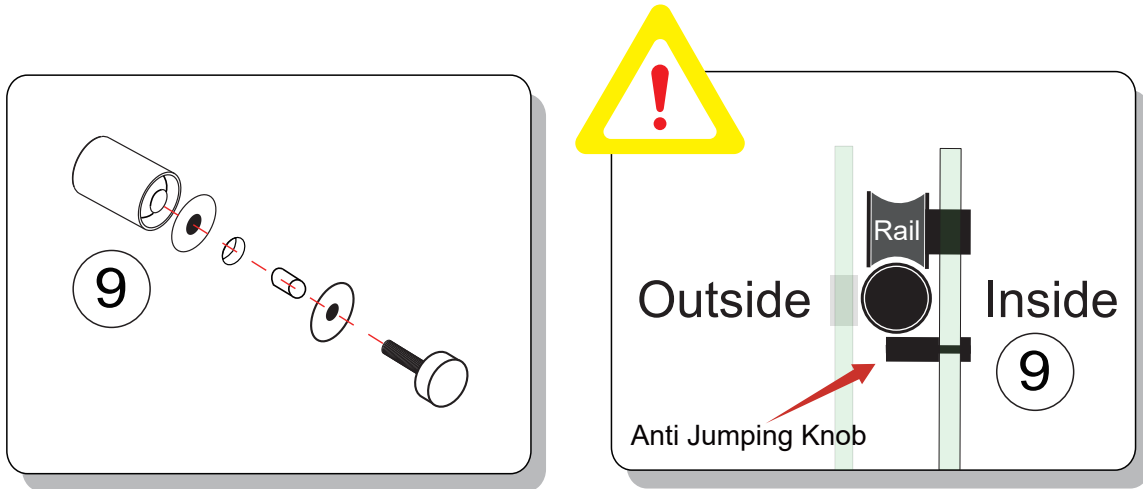

10. Install the Anti jumping knob (9) to the Sliding Glass Door (10). Make sure that the clear gasket will be between the glass and the metal parts of the Anti jumping knob (9). The distance between the Anti jumping knob (9) and the Upper Guide Rail (1) should be less than 1mm to prevent the glass from falling off.

Step 17

Pre-Install the Anti-Splash Threshold (17) and Covers (16) (18) in front of the Sliding Door (10), put the Anti-splash Threshold Cover (10), put the Anti-splash Threshold Cover (18) with slot corresponds to the end of the Stationary Glass(13). And mark down the appropriate position, then put silicone sealant to the bottom of the Anti-splash threshold and Covers, secure it to the floor.

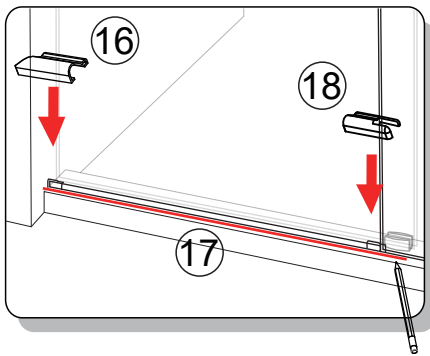
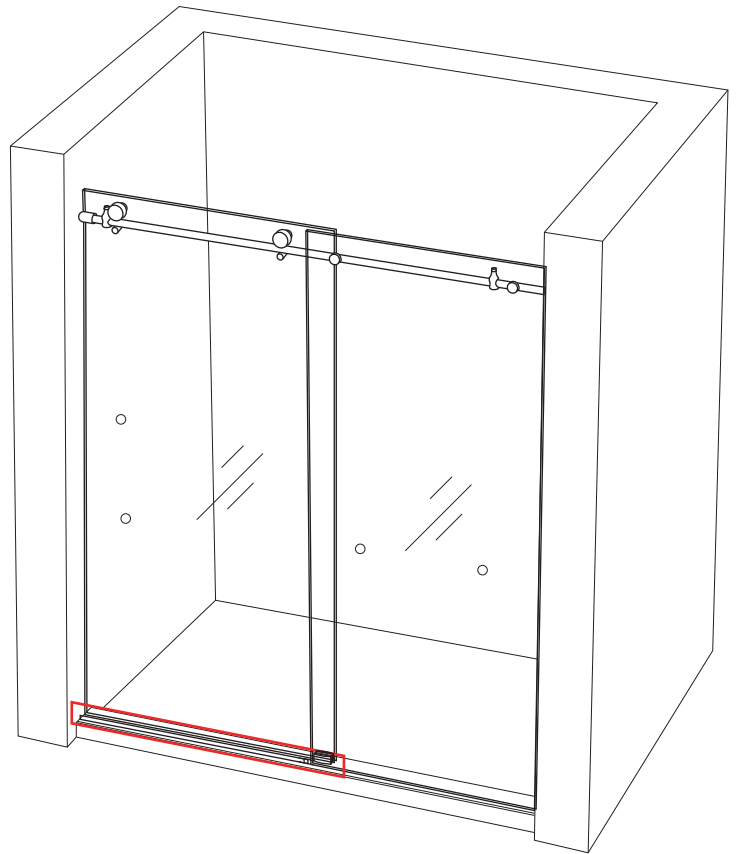

1. Pre-install and mark.

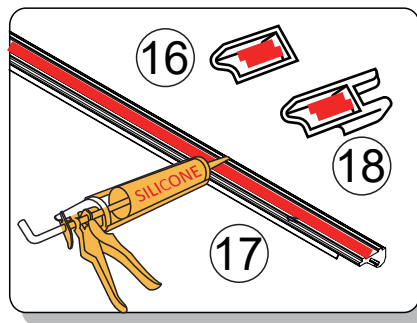

2. Apply glass sealant

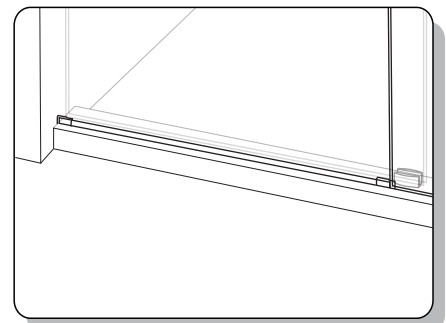

3. Install the shreshold

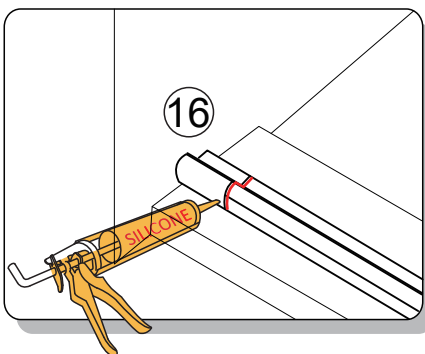

4. Seal and waterproof

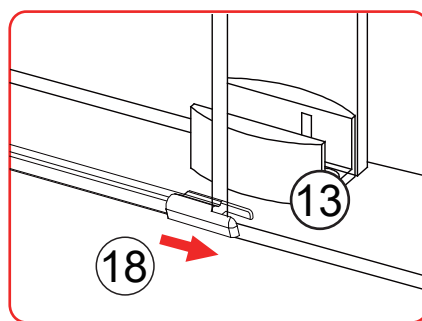

5. Seat the U Cover snugly (18) against the Stationary Glass (13), then seal and waterproof.

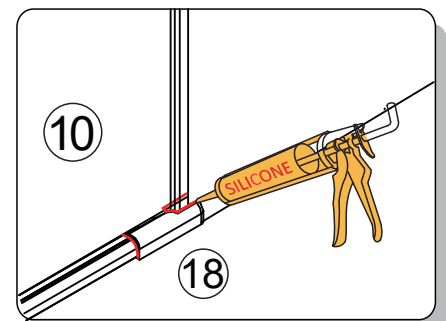

Step 18

Seat the Anti-Water H Strip (11) to the Glass Door (10), and Seat the 2 pieces Anti-Water F Strips (12) with an extended side to the middle glass, cut the extended side that interferes with the Upper Guide Rail (1).

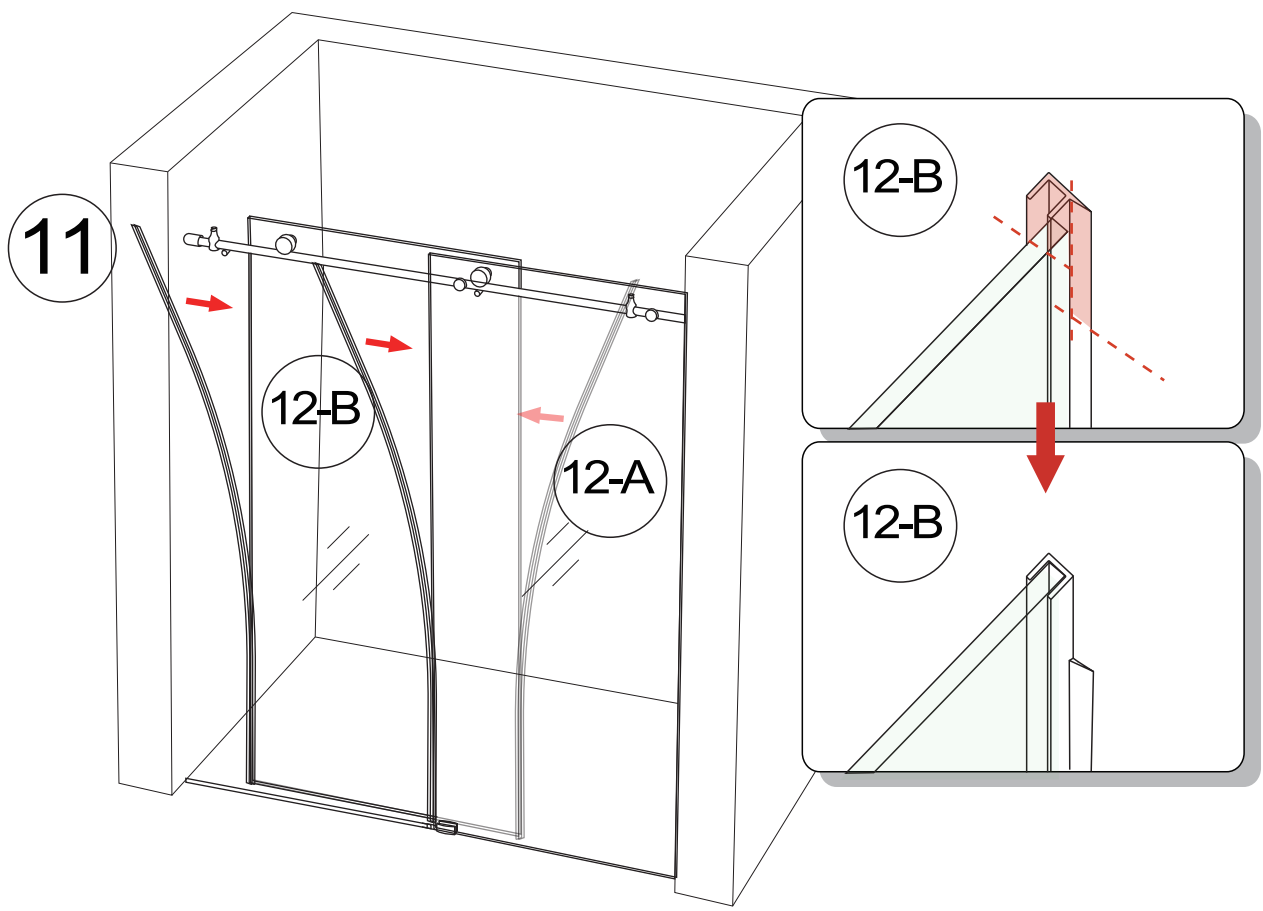
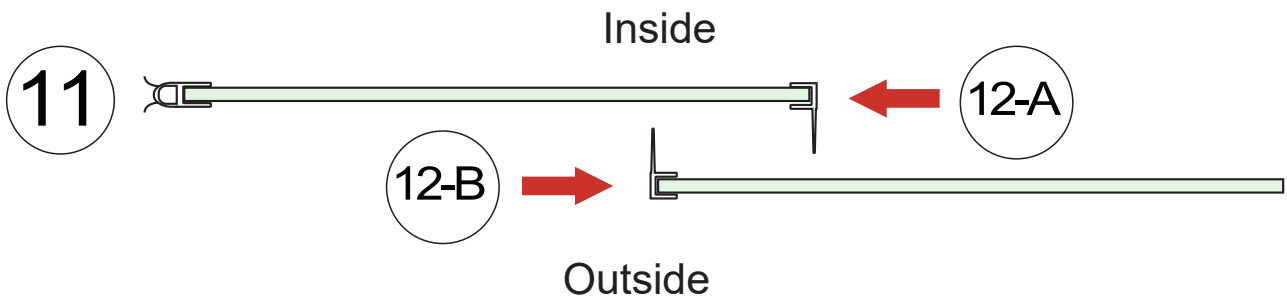
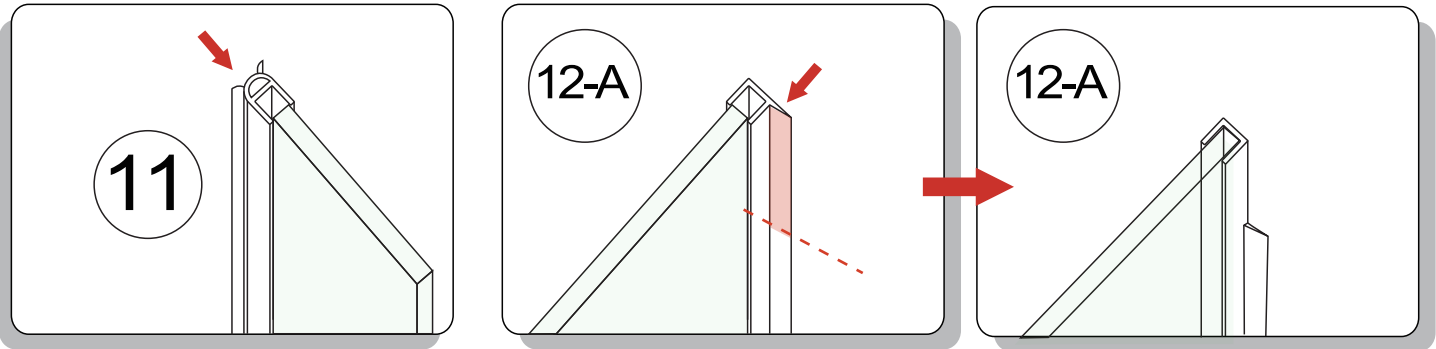

Step 19

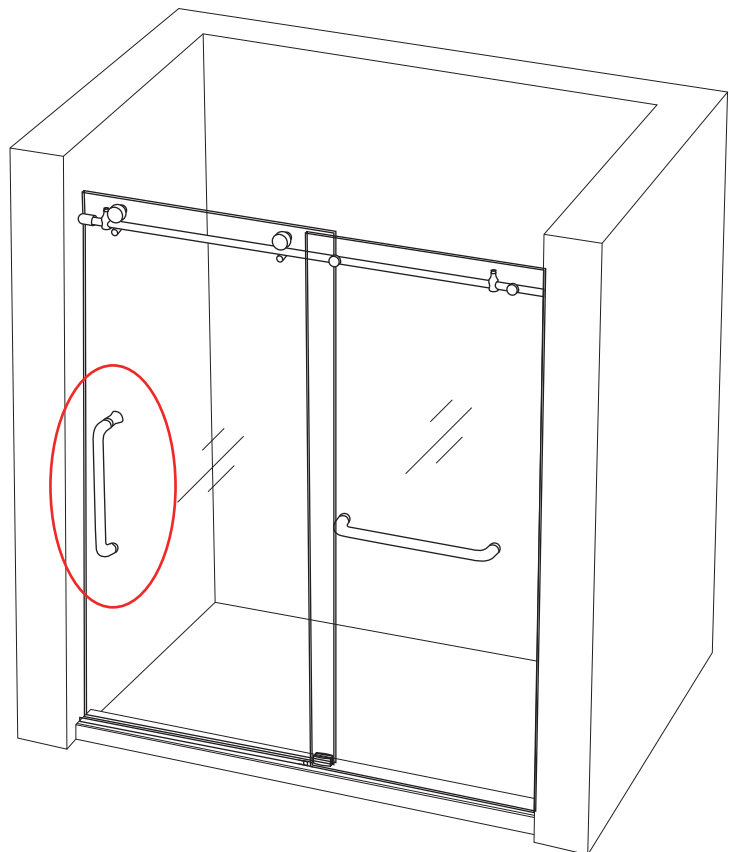
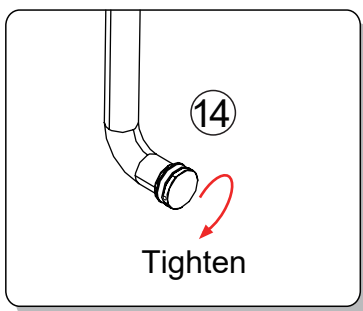
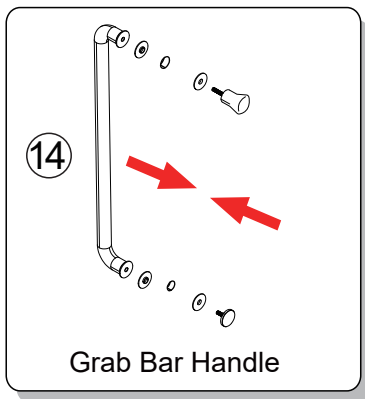
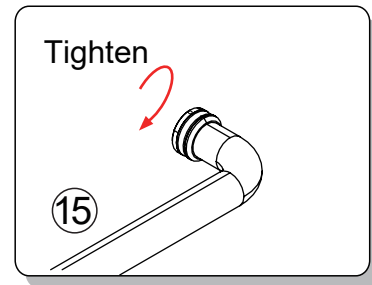
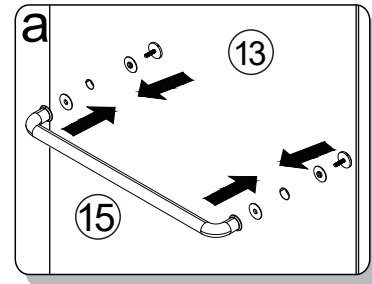
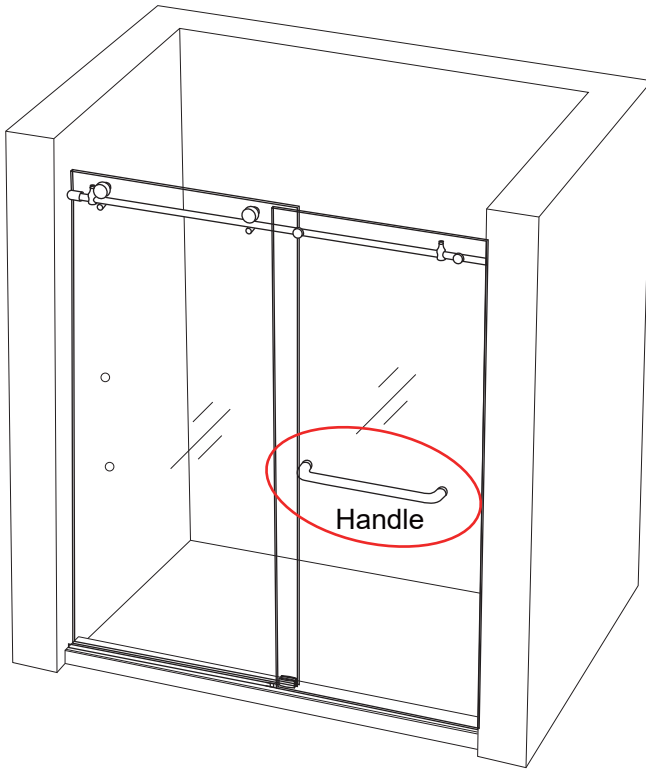

Step 20

Slide the sliding glass snugly against the wall, fasten the Left Stopper (4) close to the left roller.

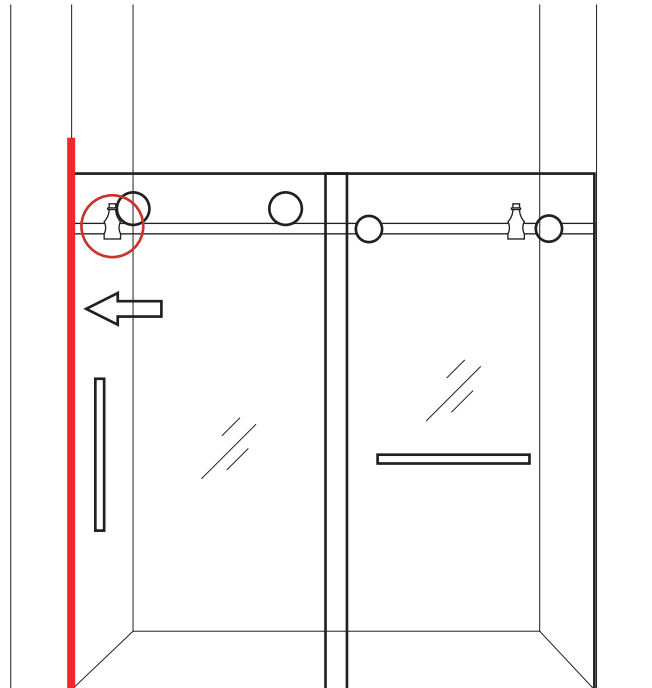
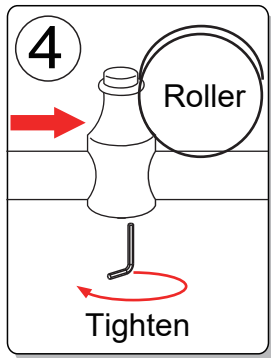
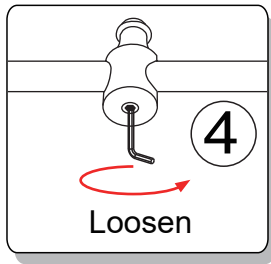

Full open the sliding glass, keep appropriate gap between the door and handle, fasten the Right Stopper (4) close to the Right roller.

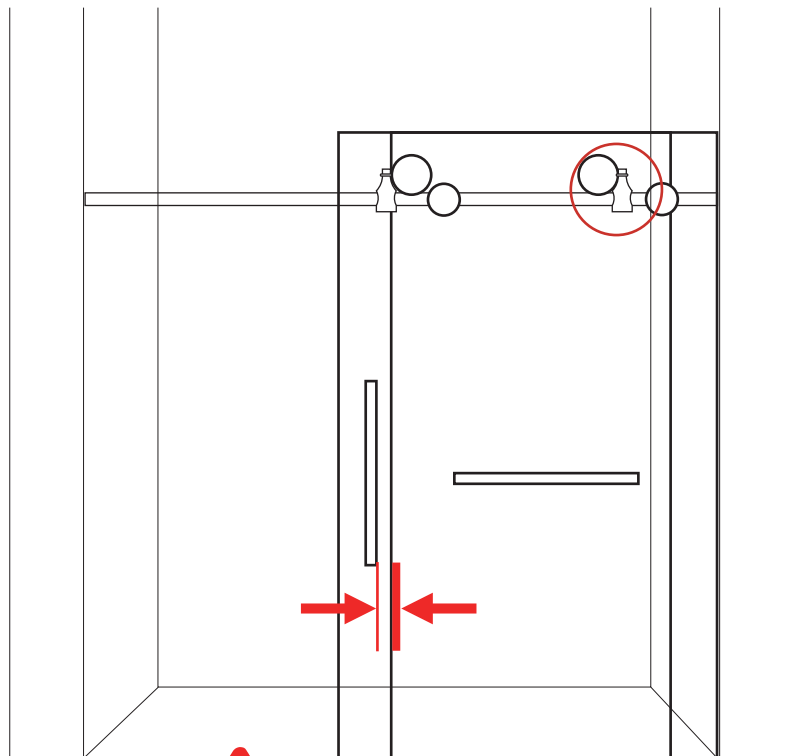
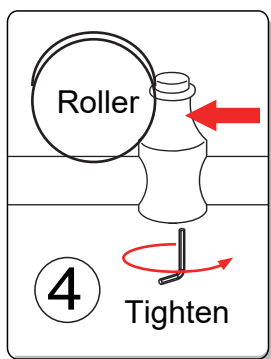
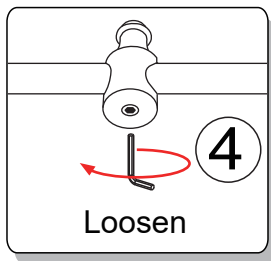

Min. 1 inch gap between handle and glass.

Step 21

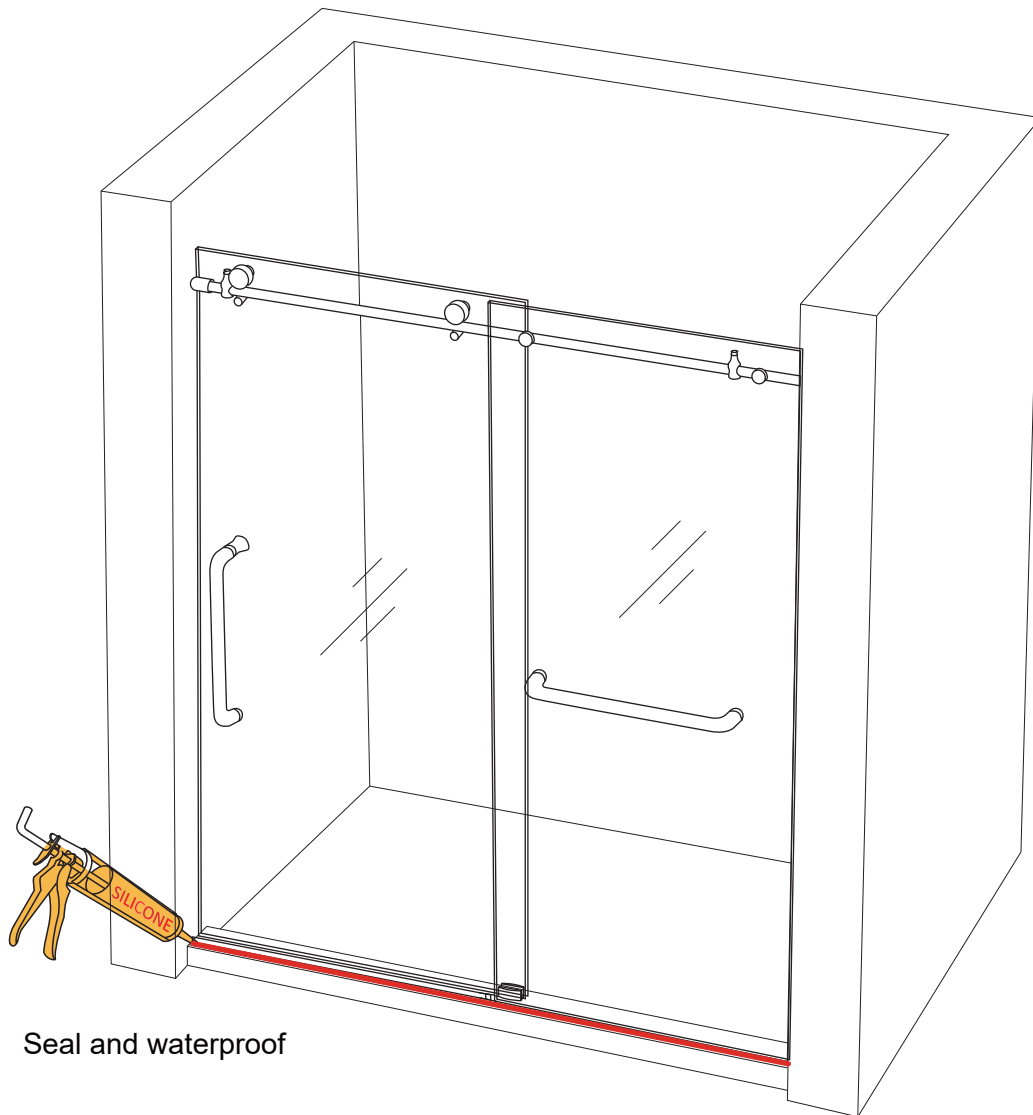

Seal and waterproof



Do not use the shower enclosure for at least 24 hours in order to allow the silicone sealant to cure fully.

CARE & MAINTENANCE



The golden rules for care

NOTE: Use warm soapy water and a soft damp cloth to keep the glass clean. Wipe dry with a clean cloth. Glass cleaner can be used if required. Scourers, abrasives and chemical cleaners can damage the glass and pattern, and should not be used.

In hard water areas, insoluble lime salts may be deposited on the glass. If this is allowed to build up it becomes increasingly difficult to remove and looks unsightly. Regular cleaning will minimize this effect.

- Do not attempt to cut the glass.
 - Do not strike the glass with hard or pointed items.
 - Regularly check moving parts such as rollers and hinges to ensure they are secure and adjusted correctly. Tighten and adjust where required. Also check all sealed joints to ensure seal has not deteriorated. Re-seal if required.
-

WARRANTY

LIMITED MANUFACTURER'S WARRANTY

- All parts and finishes of Getpro products are warranted to the original consumer purchaser to be free from defects in material and workmanship for a period of two to five years [depending on the product and model: please check the product listing or email us at support@trendytotesinc.com if you are unsure after the date of original retail purchase. Proof of the original purchase is required to obtain a remedy under this limited warranty.
- Getpro recommends using a certified professional for all installation and repair of kitchen and bathroom fixtures.
- Getpro will replace, free of charge, during the warranty period any part or finish that proves defective in material and/ or workmanship under normal installation, use and service. Replacement parts may be obtained by emailing us at support@trendytotesinc.com
- This warranty is extensive in that it covers replacement of all defective parts and even finish, but these are the only two things that are covered. Labor charges and/or damage incurred in installation, repair, or replacement as well as any other kind of loss or damages are excluded.
- Proof of purchase (original sales receipt) from the original consumer purchaser must be made available to Getpro for all warranty claims. This is the exclusive warranty by Getpro, which does not make any other warranty of any kind including the implied warranty of Merchant ability. This warranty excludes all industrial, commercial and business usage whose purchasers are hereby extended a one-year limited warranty from the date at purchase, with all other terms of this warranty applying except the duration of the warranty.

WHAT IS NOT COVERED UNDER THIS LIMITED WARRANTY

- Normal wear and tear, spills of food, liquid, grease accumulations or cosmetic damage.
- Damage due to accidents, misuse, physical force improper installation or operation, mishandling, neglect, fire, heat, water, humidity, liquids, insect infestation, or other intrusion.
- Products that have been repaired, altered or modified by anyone other than Getpro or its authorized service representative.
- Damage caused by use of non-Getpro accessories or misapplication Products whose serial numbers have been removed altered or rendered illegible.
- Products purchased, shipped from, used or serviced outside the United States. Canada and Mexico.
- Damage caused by acts of nature such as, but not limited to, lightning damage.
- Products returned without valid proof of purchase.
- Consumable parts such as light bulbs, metal, and charcoal filters.
- Any party's willful misconduct, negligence, misuse, abuse, accidents, neglect, improper operation, failure to maintain, improper or negligent installation, tampering, failure to follow operating instructions, mishandling, unauthorized service (including self-performed "fixing" or exploration of the product's internal workings).
- Use of corrosive or abrasive cleaning products.
- Cosmetic damages including scratches, dents, chips and other damage, unless such damage results from defects in materials and workmanship and is reported to Getpro within 3 calendar days of delivery.
- Use of the Product in anything other than its normal customary and intended manner.
- A failure to comply with any applicable state, local city or county electrical, plumbing and/or building codes, regulations, or laws, including failure to install the product in strict conformity with local fire and building codes and regulations.
- In no event shall Getpro have any liability or responsibility whatsoever for damage to surrounding property, including cabinetry, floors, ceilings, and other structures or objects around the product.

NO ATTEMPT TO ALTER, MODIFY, OR AMEND THIS WARRANTY SHALL BE EFFECTIVE UNLESS AUTHORIZED IN WRITING BY AN OFFICER OF Getpro

 support@trendytotesinc.com

HOME SERVICES



INSTALLATION VIDEO

Missing Part or Defective?

Please Contact the Customer Service Team

✉ service@getprohome.com

☎ 626 679 3588