

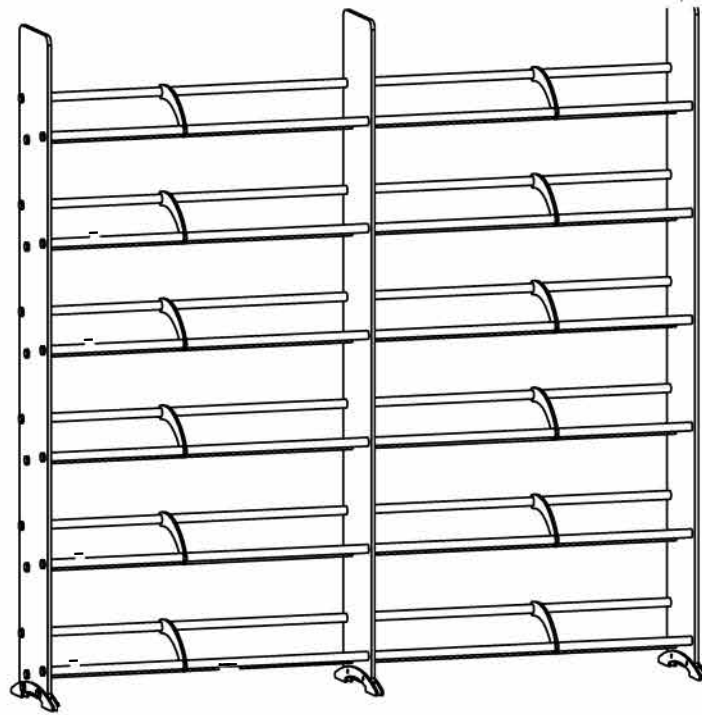









# Assembly Instructions





ase

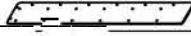

## Hardware

Part #	Description		QTY
A	Screw M6x19mm		36
B	Metal Cap		40
C	Brass Washer		40
D	Screw M6x25mm		6
E	Metal Washer		8
F	Nut		6
G	Double ended Stud M6x32mm		18
H	Allen Wrench		1
I	Wrench		1

## Parts

Part #	Description		QTY
1	Class Panel		3
2	Rod		36
3	Metal Feet		6
4	Stopper		12

## STEP 1

- 1a. Install the metal feet as shown in the diagram with provided tools.
- 1b. Do not fasten the screws until the whole unit set up and leveled in upright position.

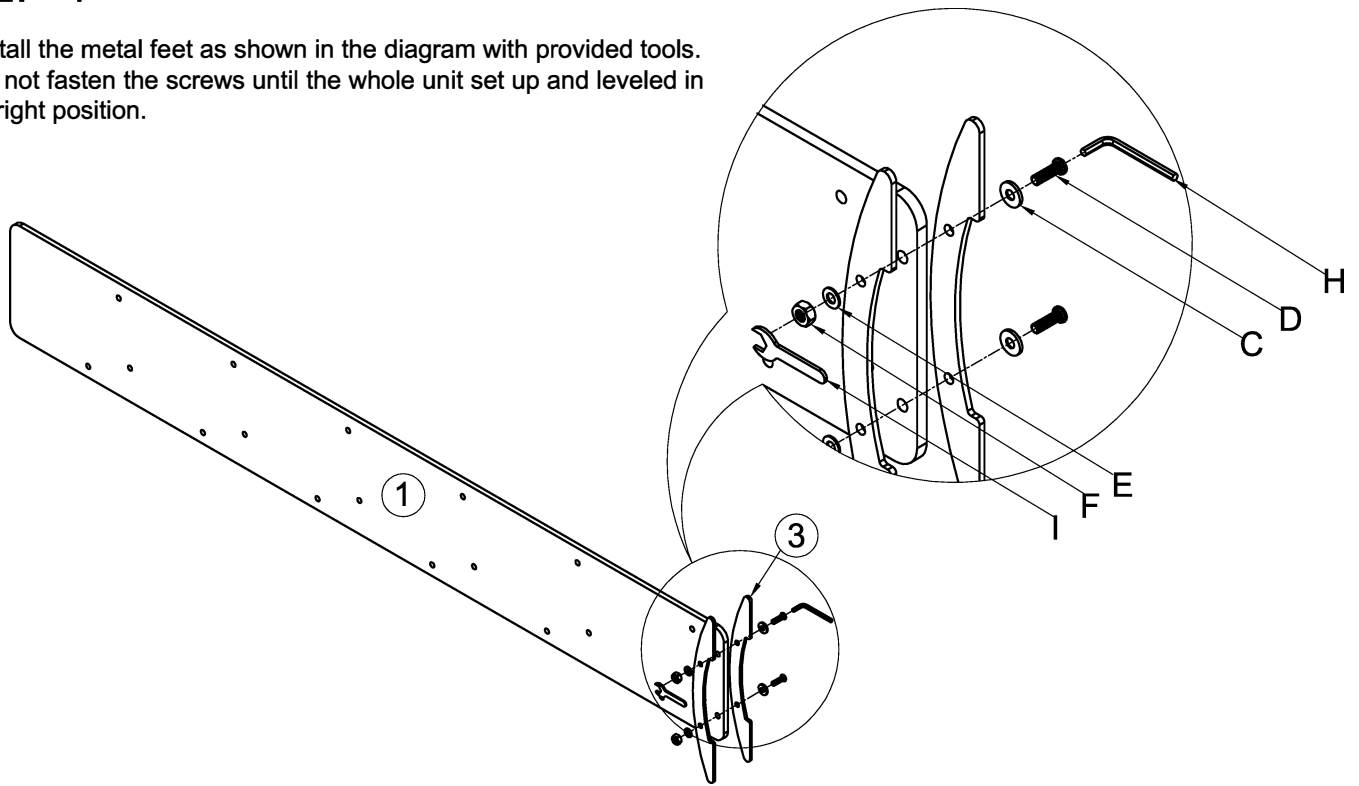

## STEP 2

- 2a. Install the rods with the brass washers (flat side against the glass) and screws (Part A).
- 2b. Fasten the screws to 90% tight, do not over tighten the screws.

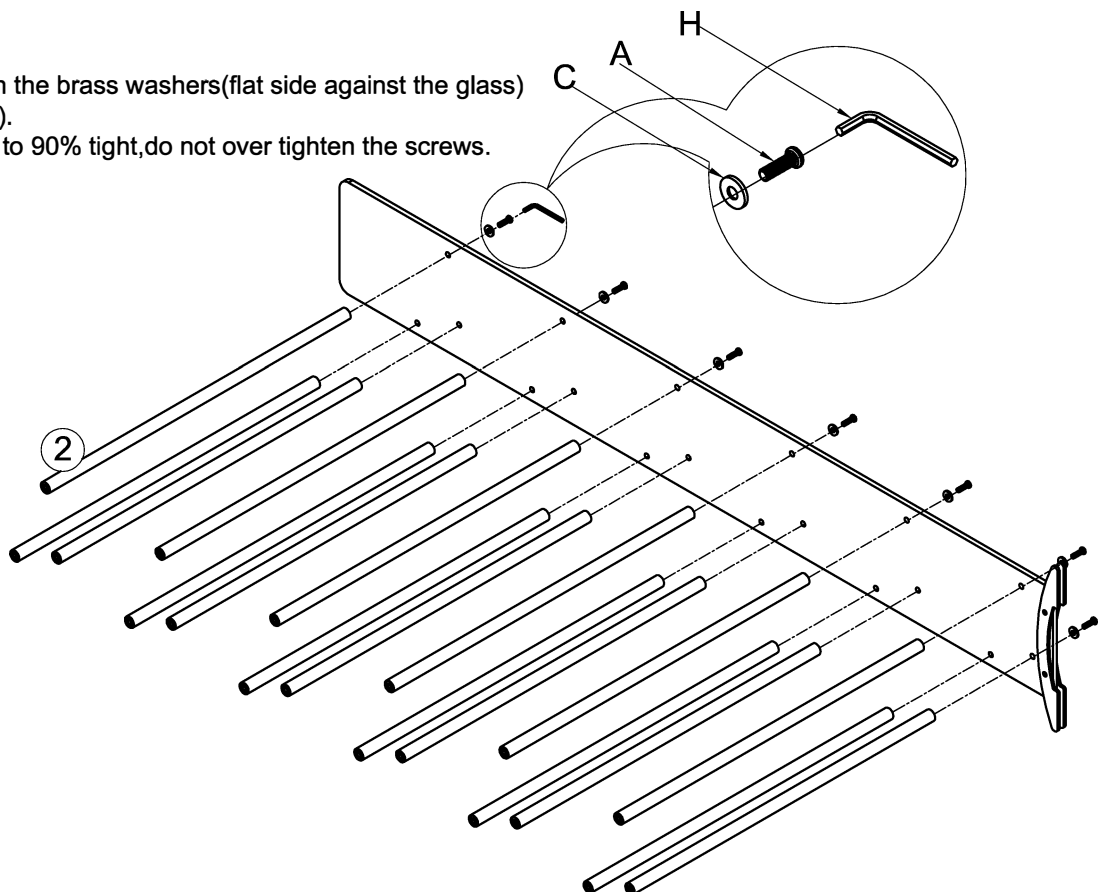

## STEP 3

Insert the stoppers into the rods as shown.

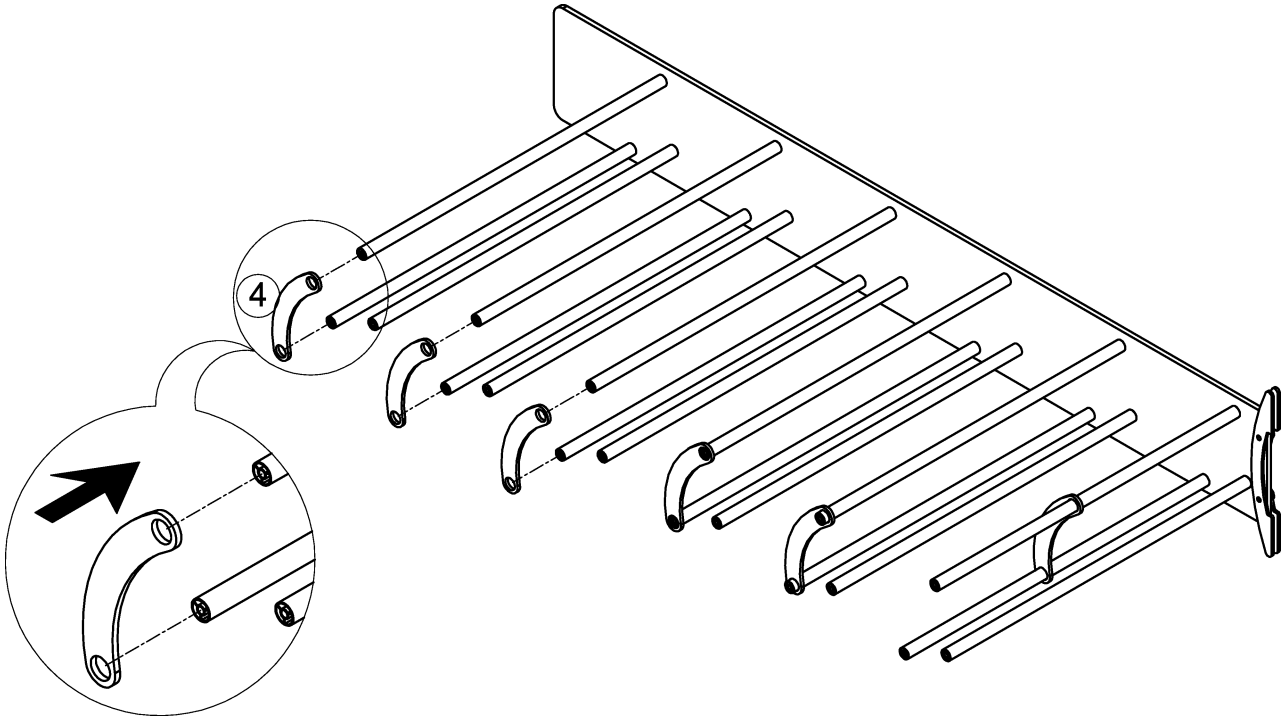

## STEP 4

- 4a. Install the metal feet as shown in the diagram with provided tools.
- 4b. Do not fasten the screws until the whole unit set up and leveled in upright position.

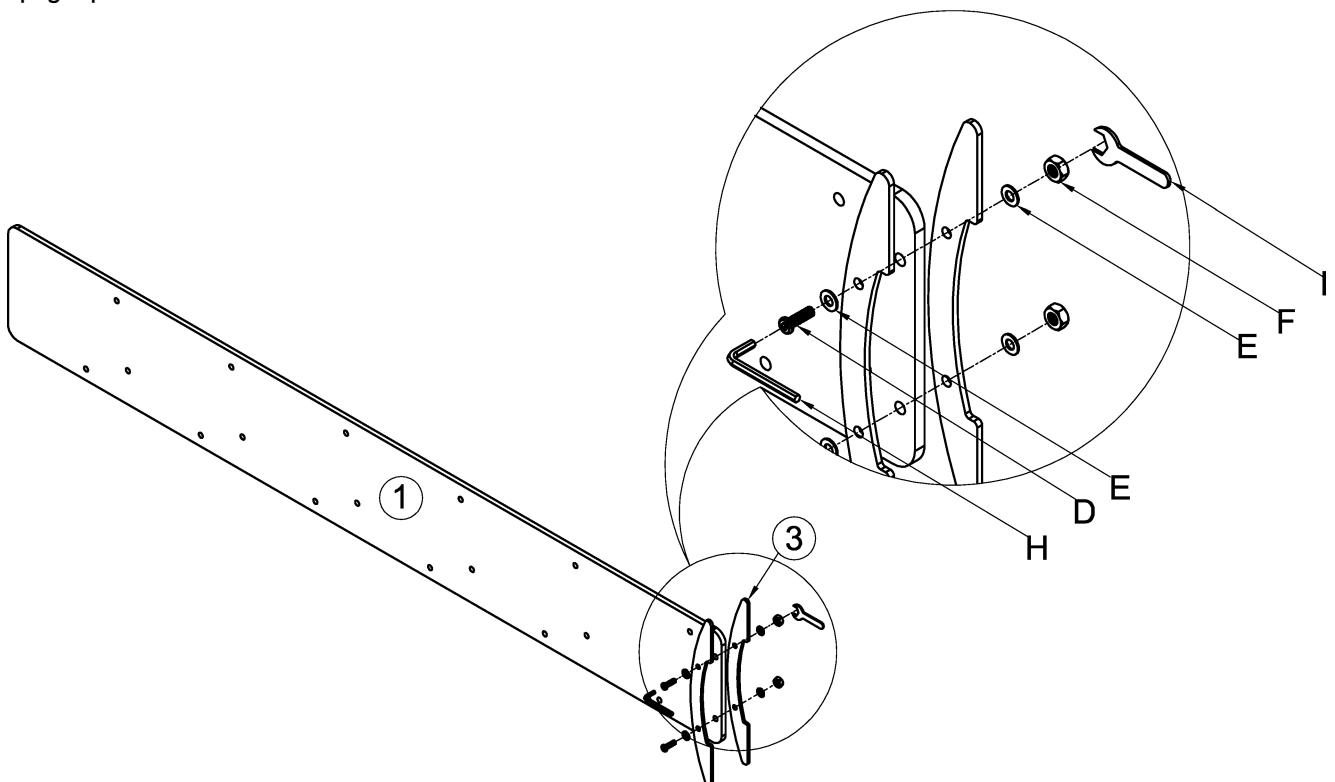

## STEP 5

Install the glass panel and the rods as shown.

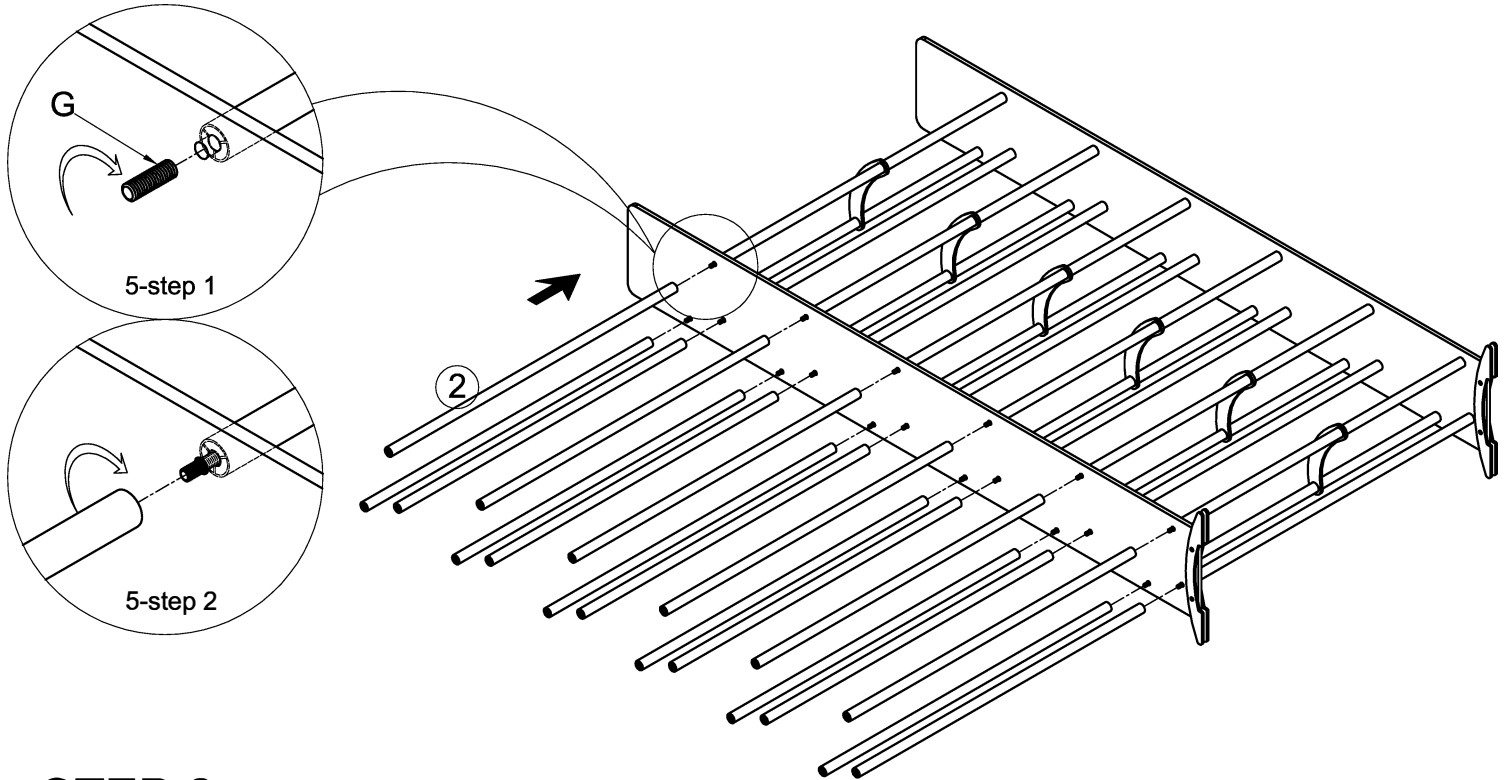

## STEP 6

Insert the stoppers into the rods as shown.

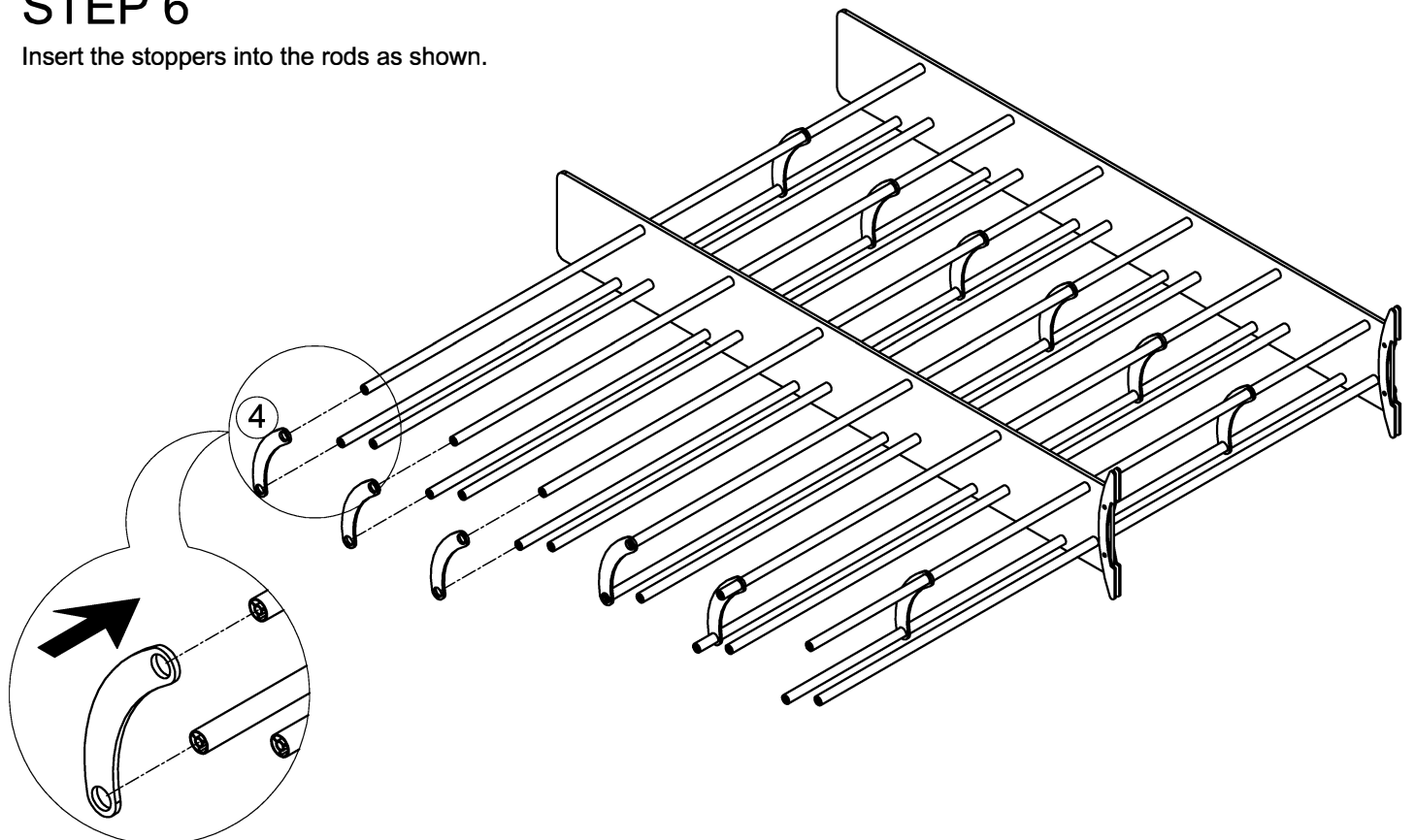

## STEP 7

- 7a. Install the metal feet as shown in the diagram with provided tools.
- 7b. Do not fasten the screws until the whole unit set up and leveled in upright position.

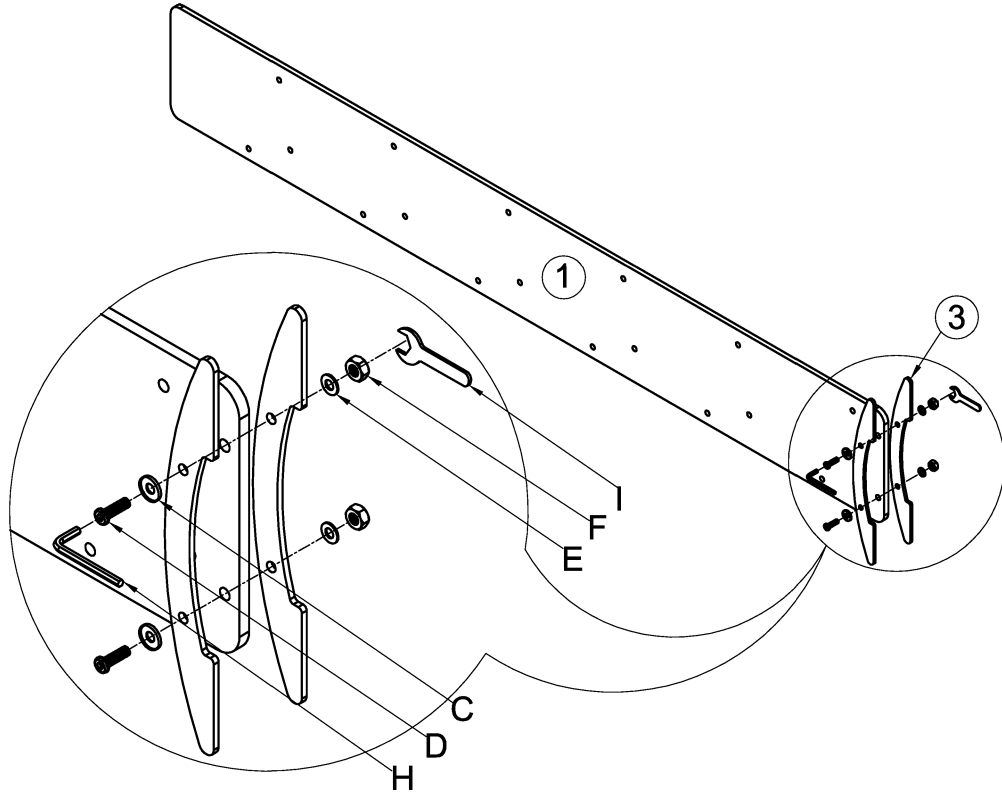

## STEP 8

- 8a. Install the glass panel with the brass washers (flat side against the glass) and screws (Part A).
- 8b. Fasten the screws to 90% tight, do not over tighten all the screws.

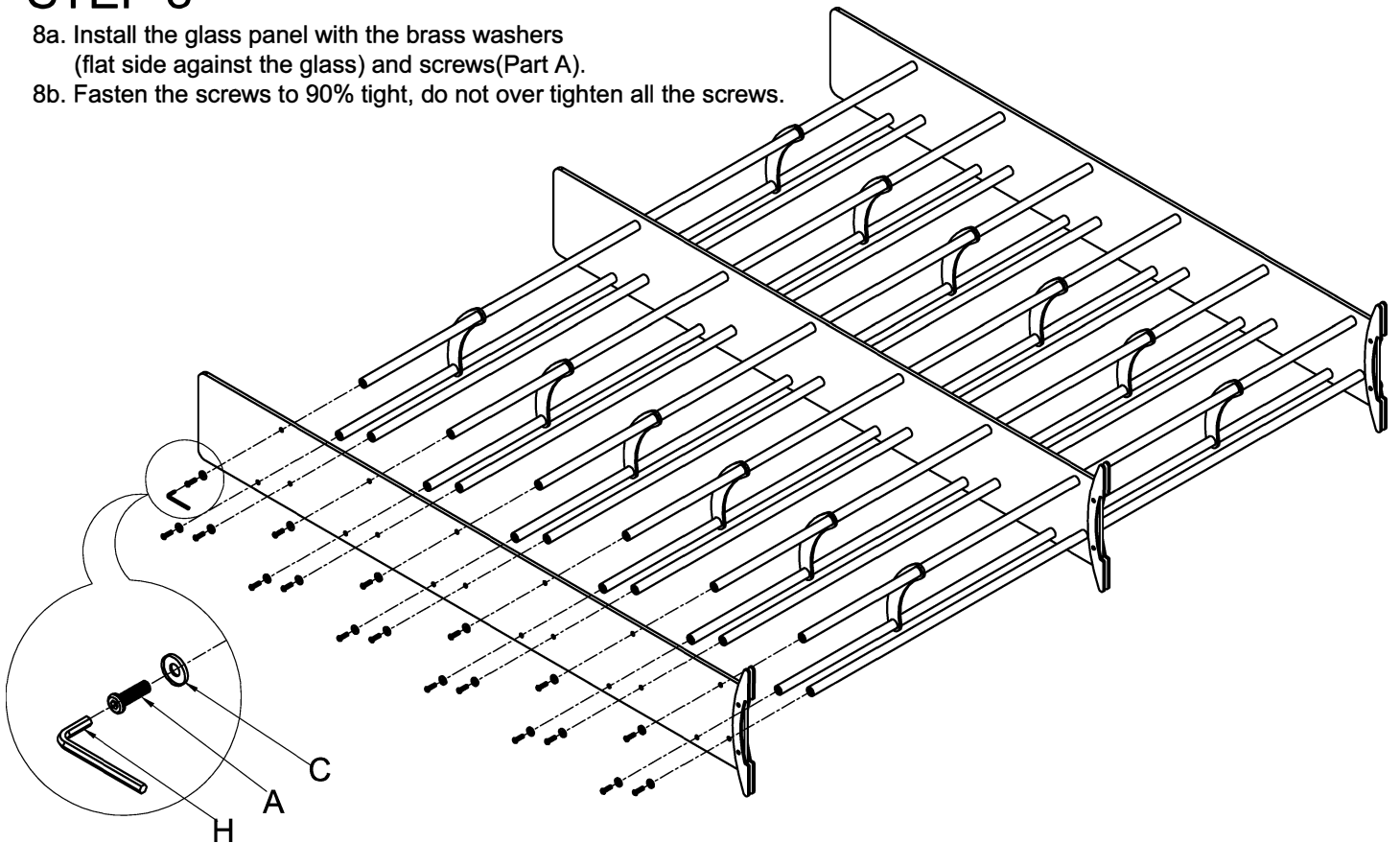

## STEP 9

- 9a. Slide each stopper from one side to the other, if it's not smooth then adjust the rod(s);  
loosen the screw(s) if necessary.
- 9b. Level the metal feet and fasten all the screws. Do not over tighten the screws.
- 9c. Install all the caps. There is no caps for the middle feet.

