

ASSEMBLY INSTRUCTIONS

ASSEMBLY REQUIREMENTS	45 Minutes Assembly Time (Approximate)	2 -Person Assembly 	Tools Required (Not Provided): Phillips Screwdriver  ⊕ Flat Head Screwdriver  ⊖
-----------------------	--	---	---

Thank you for purchasing our product!

Please refer and use this assembly instruction to assemble the product.
Contact our customer service department in case there are any missing or damage parts or hardware.
Replacement parts are normally shipped within 2 or 3 days.

PRODUCTS PURCHASED THROUGH OUR AUTHORIZED VENDORS ONLY ARE ELIGIBLE FOR REPLACEMENT PARTS.

THIS PRODUCT IS FOR INDOOR AND HOUSEHOLD USE ONLY - NOT FOR COMMERCIAL USE.

ASSEMBLY PREPARATION

1. Remove all packaging materials, staples and packing straps from the carton.
2. Refer to Parts List and Hardware List and ensure they are correct before assembly.
Contact customer service for missing parts.
3. Place all wooden parts on a clean, flat and soft surface (e.g. carpet or rug) to prevent parts from getting scratched.

SAFETY PRECAUTION

1. KEEP ALL HARDWARE PARTS OUT OF REACH OF CHILDREN.
2. DISPOSE PLASTIC PACKAGING MATERIAL IMMEDIATELY TO AVOID ANY RISK OF SUFFOCATION TO CHILDREN AND ANIMALS.

TIPS FOR ASSEMBLY

1. Allow ample room for assembly and in close proximity to where product will be placed.
2. Assemble the product on a surface that does not scratch or damage the exterior gloss and finish of the furniture.
3. Identify all of the parts, hardware and quantities required for each step.
4. During assembly, do not over-tighten any fittings as this may cause damage.
5. DO NOT USE POWER TOOLS TO ASSEMBLE THIS PRODUCT.
6. Always place the product on a flat, level surface.
7. Do not sit or stand on the partially assembled product; only use the product for which it is intended.



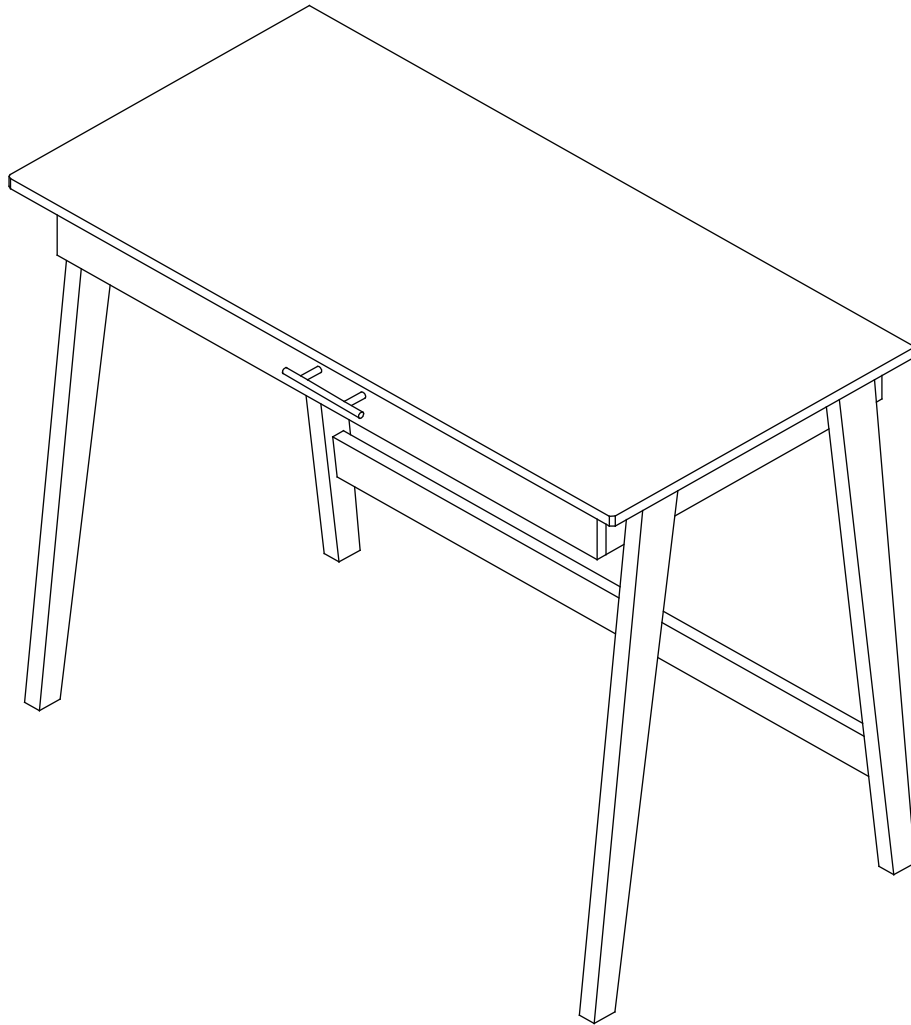

CARE AND MAINTENANCE

1. Wipe clean with a soft, dry cloth; avoid the use of harsh chemicals or household cleaners as they may damage the exterior finish of the furniture.
2. Hardware may loosen over time. Periodically, check that all connections are tight; re-tighten as necessary.
3. Solid wood is impacted by heat and humidity fluctuations which may cause small joint separations or hairline cracks; place the furniture away from direct sunlight and air conditioning vents, heating vents or units to protect the furniture.

ASSEMBLY INSTRUCTIONS







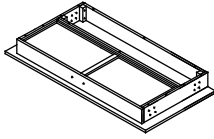

Hardware List

ITEM	DESCRIPTION	PART	QTY	ITEM	DESCRIPTION	PART	QTY
A	Bolt	 6*35mm	16 pcs	E	Wood Dowel	 6*30mm	4 pcs
B	Cam-Bolt	 6*35mm	4 pcs	F	Handle		1 pc
C	Cam-Lock	 15*12mm	4 pcs	G	Flat Washer		16 pcs
D	Handle Bolt		2 pcs	H	Allen Wrench		1 pc

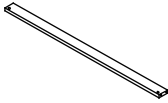
ASSEMBLY INSTRUCTIONS

Parts List

ITEM	DESCRIPTION	PART	QTY	ITEM	DESCRIPTION	PART	QTY
1	Desk Top		1 pc	4	Right Front Leg		1 pc
2	Connect Bar		2 pcs	5	Left Back Leg		1 pc
3	Left Front Leg		1 pc	6	Right Back Leg		1 pc

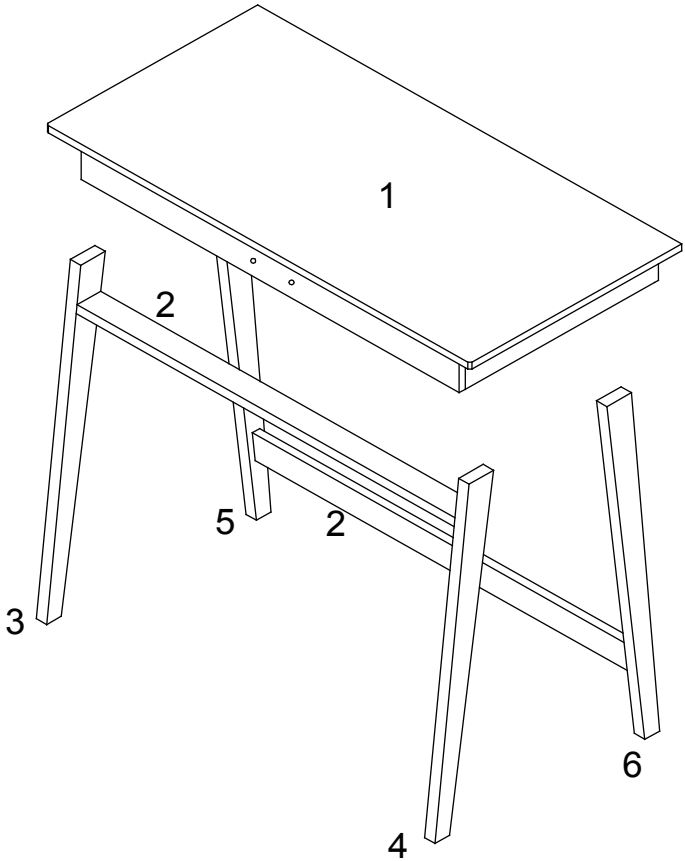

Instructions For Fastening CAM-BOLT AND CAM-LOCK

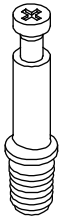

CAM-BOLT



CAM-LOCK

Tools Required

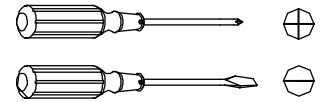

INSERTING AND TIGHTENING CAM-BOLT

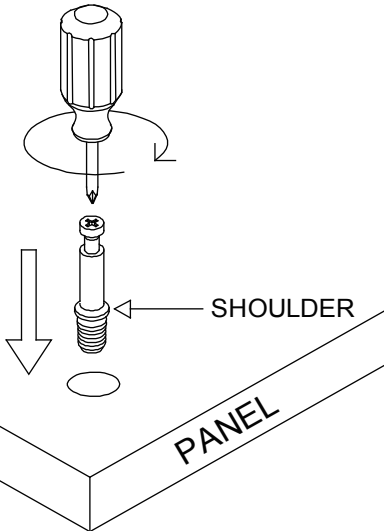

Place Cam-bolt on pre-drilled hole and screw in vertically.

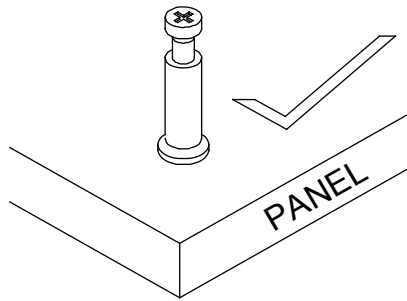

Shoulder is flushed (on the same level) with the panel.

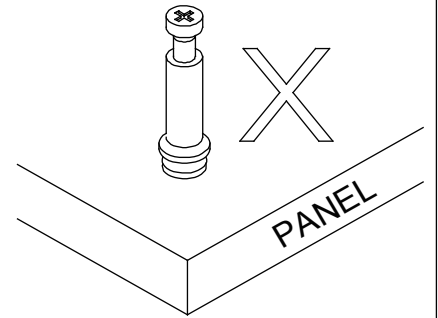

Shoulder is above the panel.

Place Cam-bolt to the designated pre-drilled holes on the panel. Use a Phillips Screwdriver to tighten Cam-bolt vertically until shoulder is flushed (on the same level) with panel. Do not over-tighten or under-tighten.

INSERTING CAM-LOCK

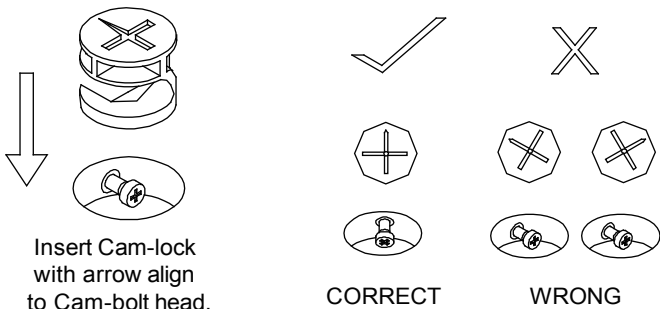

Insert Cam-lock with arrow align to Cam-bolt head.

CORRECT

WRONG

Align the arrow on the Cam-lock to the Cam-bolt head and insert the Cam-lock. Ensure Cam-lock is fully inserted.

TIGHTENING CAM-LOCK

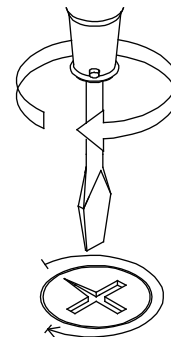

Use a Flat-head Screwdriver to turn Cam-lock clockwise so it locks onto the head of the Cam-bolt. Turn until it is snug (about 3/4ths of a turn) -- over-tightening could damage Cam-lock or/and Cam-bolt.

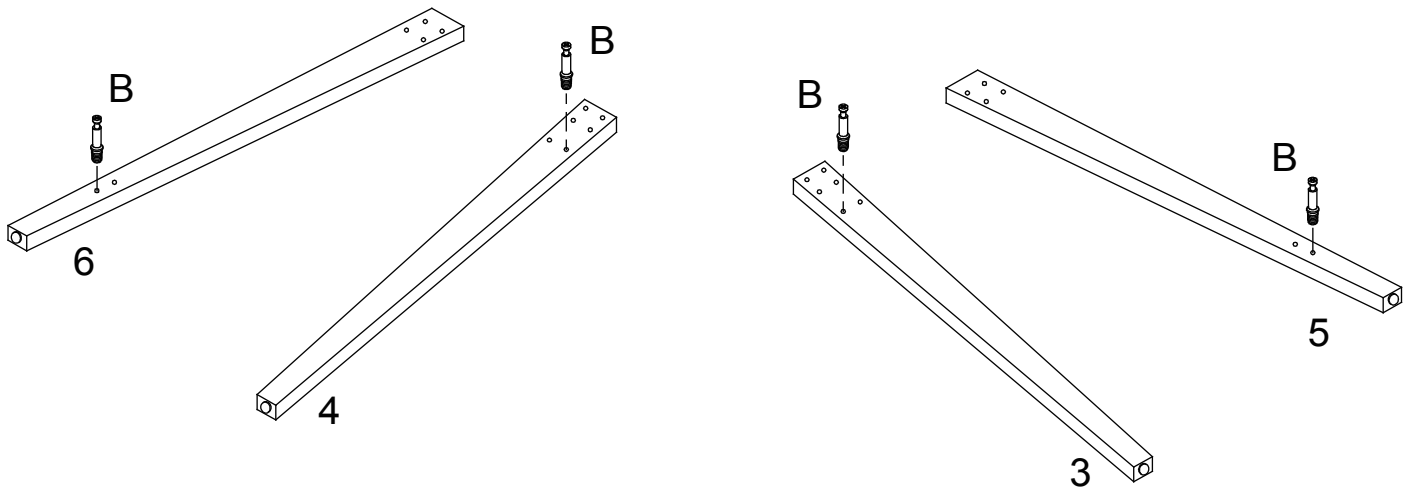
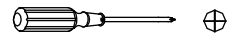

STEP 1

B		4 pcs
---	--	-------



- Lay Legs (3, 4, 5 and 6) with the inside-face facing up as shown on a material that does not scratch the surfaces of the parts.
- Place Cam-bolt (B) on the designated pre-drilled holes on (3, 4, 5 and 6) as shown, and use a Phillips screwdriver to drive cam-bolts. Refer to Page 4 for Instructions on fastening Cam-bolt.

STEP 2

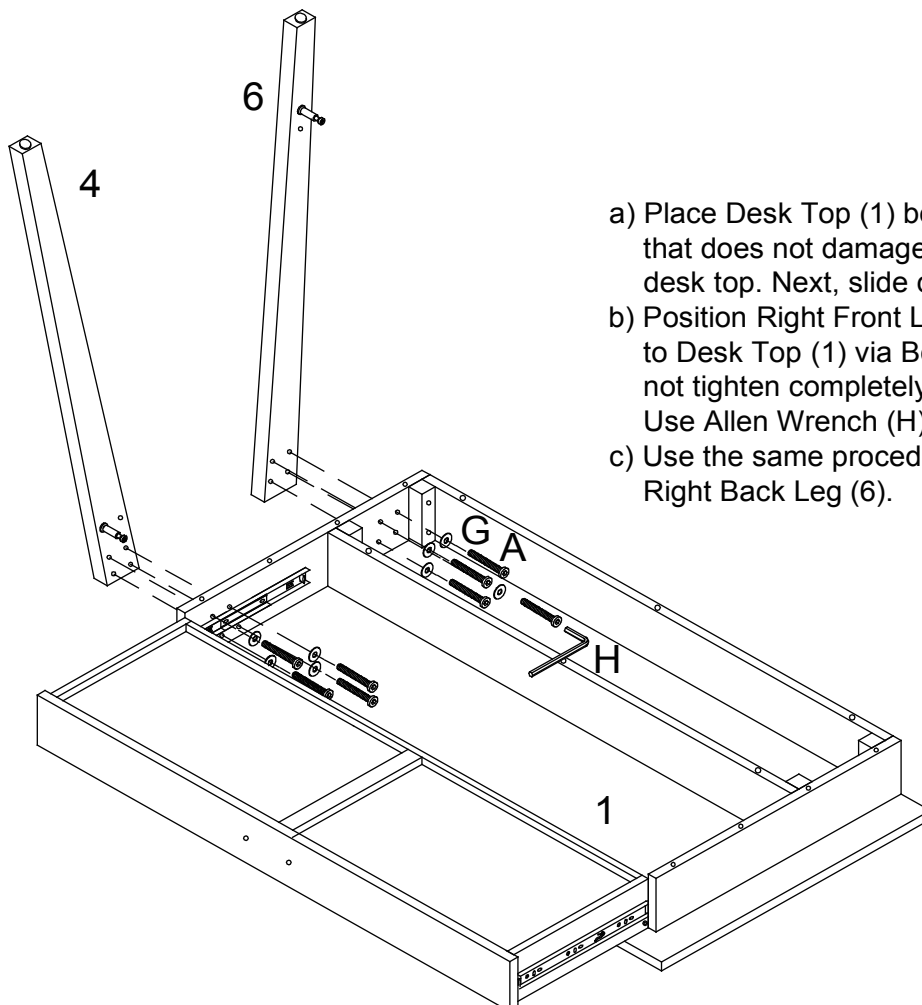

A		8 pcs
G		8 pcs
H		1 pc

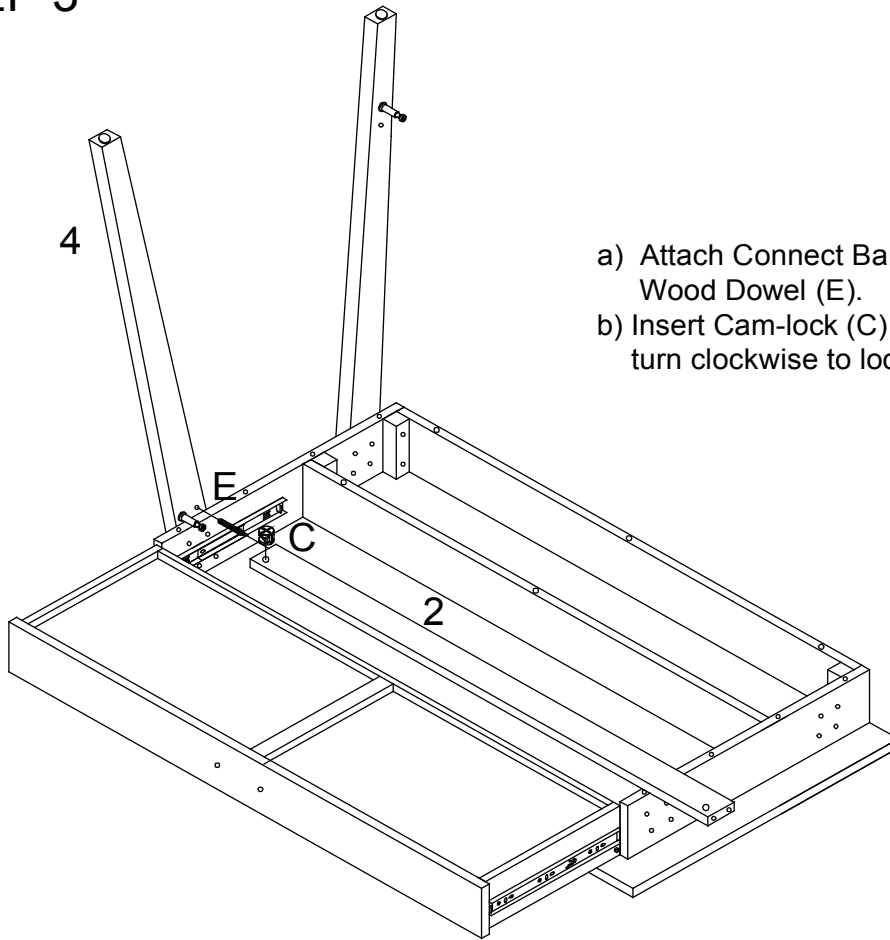

- Place Desk Top (1) bottom-side up on a material that does not damage or scratch the surface of desk top. Next, slide drawer out fully.
- Position Right Front Leg (4) as shown and attach to Desk Top (1) via Bolt (A) & Flat Washer (G). Do not tighten completely until all the bolts are in place. Use Allen Wrench (H) to tighten Bolt (A).
- Use the same procedures in Step b) to assemble Right Back Leg (6).

STEP 3





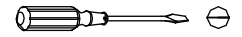

C		1 pc
E		1 pc

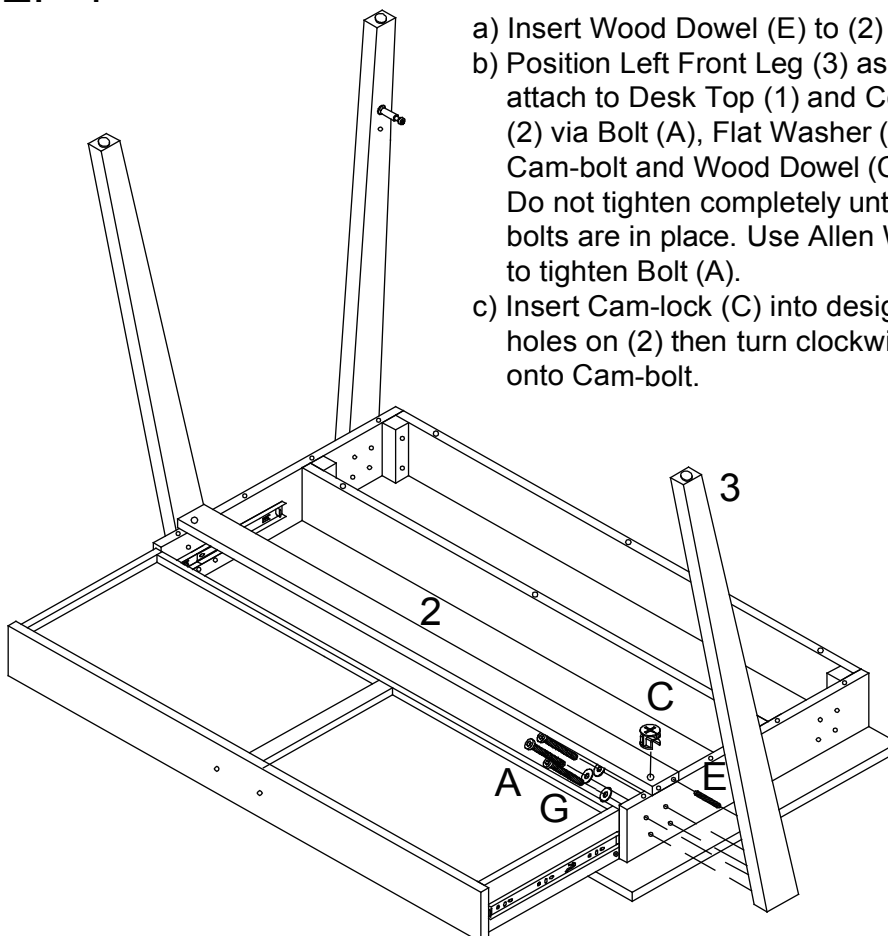

- Attach Connect Bar (2) to Leg (4) via Cam-bolt and Wood Dowel (E).
- Insert Cam-lock (C) into designated holes on (2) then turn clockwise to lock onto Cam-bolt.

STEP 4



A		4 pcs
C		1 pc
E		1 pc
G		4 pcs

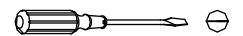

- Insert Wood Dowel (E) to (2) as shown.
- Position Left Front Leg (3) as shown and attach to Desk Top (1) and Connect Bar (2) via Bolt (A), Flat Washer (G), Cam-bolt and Wood Dowel (C). Do not tighten completely until all the bolts are in place. Use Allen Wrench (H) to tighten Bolt (A).
- Insert Cam-lock (C) into designated holes on (2) then turn clockwise to lock onto Cam-bolt.

STEP 5

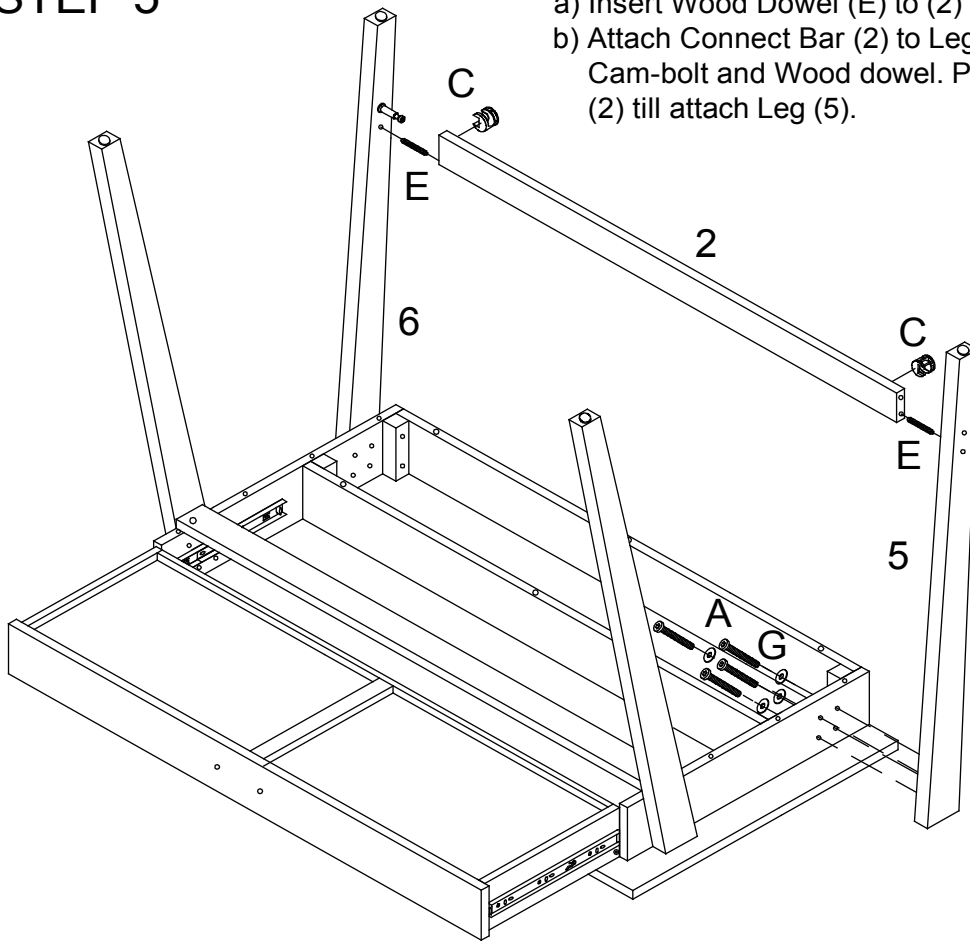

- a) Insert Wood Dowel (E) to (2) as shown.
 b) Attach Connect Bar (2) to Leg (6) via Cam-bolt and Wood dowel. Please hold (2) till attach Leg (5).

A		4 pcs
C		2 pcs
E		2 pcs
G		4 pcs

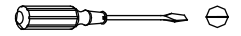

- c) Position Left Back Leg (5) as shown and attach to Desk Top (1) and Connect Bar (2) via Bolt (A) & Flat Washer (G), Cam-bolt and Wood Dowel (C). Do not tighten completely until all the bolts are in place. Use Allen Wrench (H) to tighten Bolt (A).
 d) Insert Cam-lock (C) into designated holes on (2) then turn clockwise to lock onto Cam-bolt.

STEP 6

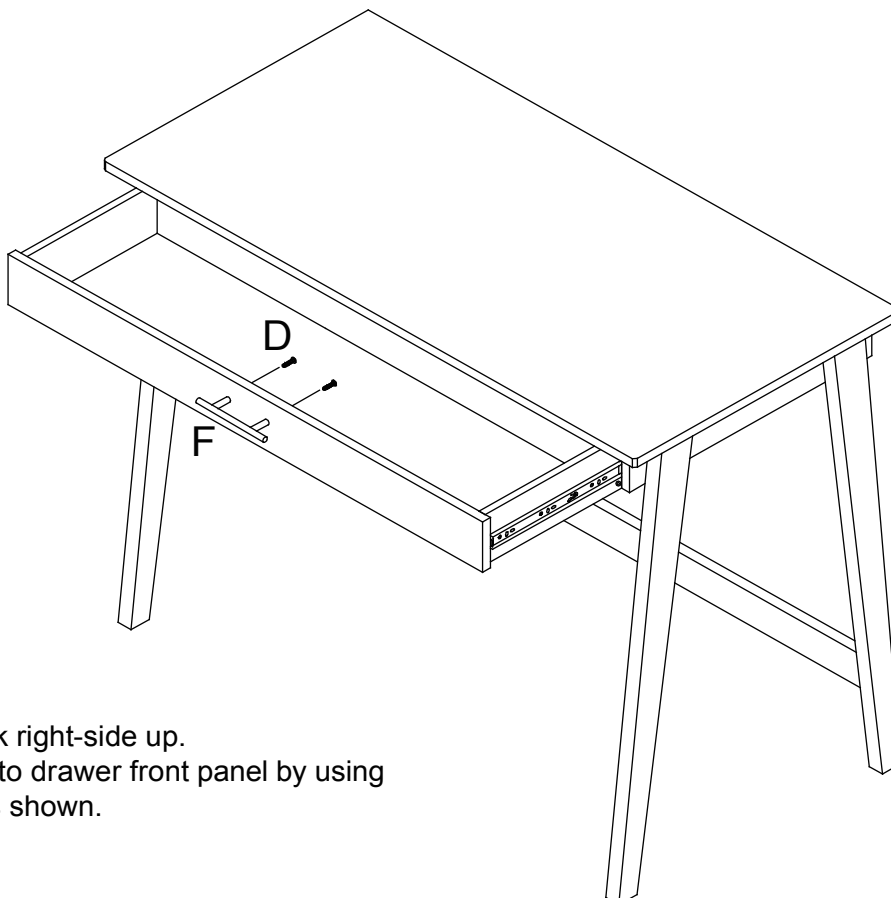

D		2 pcs
F		1 pc

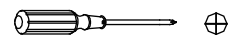

- a) Position the desk right-side up.
 b) Affix Handle (F) to drawer front panel by using Knob Bolt (D) as shown.