

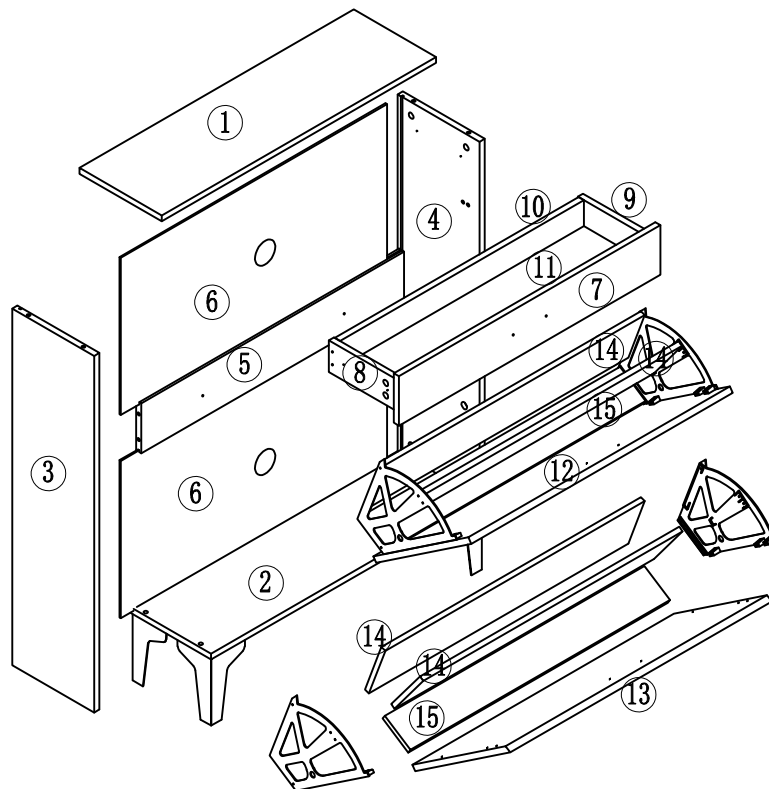

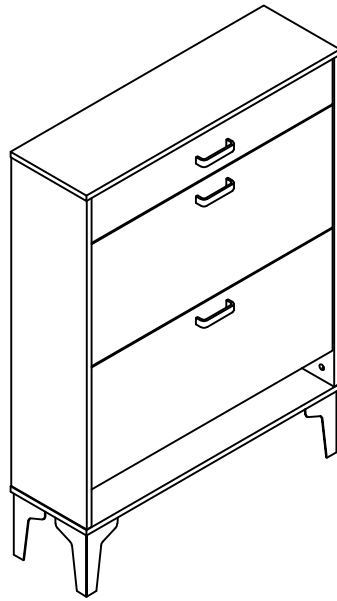







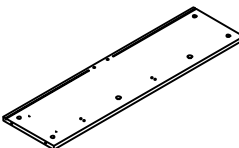
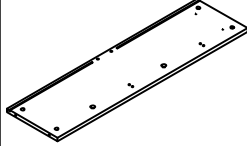
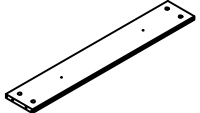
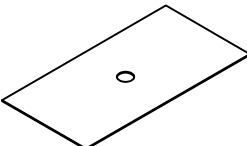
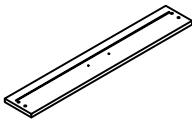

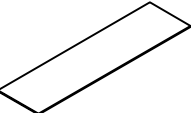
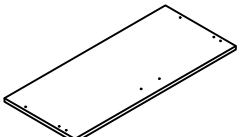
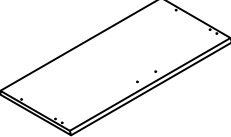
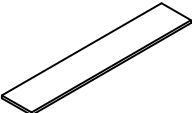
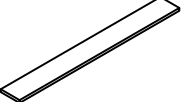

ASSEMBLY INSTRUCTIONS

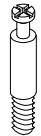

Part List

				
① x1Pc	② x1Pc	③ x1Pc	④ x1Pc	⑤ x1Pc
				
⑥ x2Pcs	⑦ x1Pc	⑧ x1Pc	⑨ x1Pc	⑩ x1Pc
				
⑪ x1Pc	⑫ x1Pc	⑬ x1Pc	⑭ x4Pcs	⑮ x2Pcs

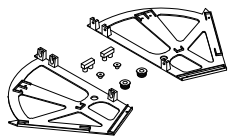
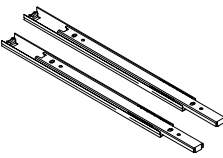
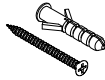
Hardware List

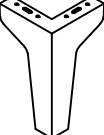
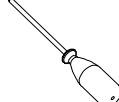
				
Ax16Pcs	Bx16Pcs	M4x14	M4x35	M4x18
				
Fx3Pcs	Gx2Pcs	Hx1Pc	Jx2Pcs	Kx2Pcs
				
Lx8Pcs	Mx4Pcs	Nx1Pc		

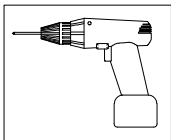

PLEASE BE CAREFUL. DO NOT DAMAGE THE HOLE POSITION WHEN YOU USE POWER TOOLS !

Step 1

Gx2Pcs	Nx1Pc	Ax12Pcs

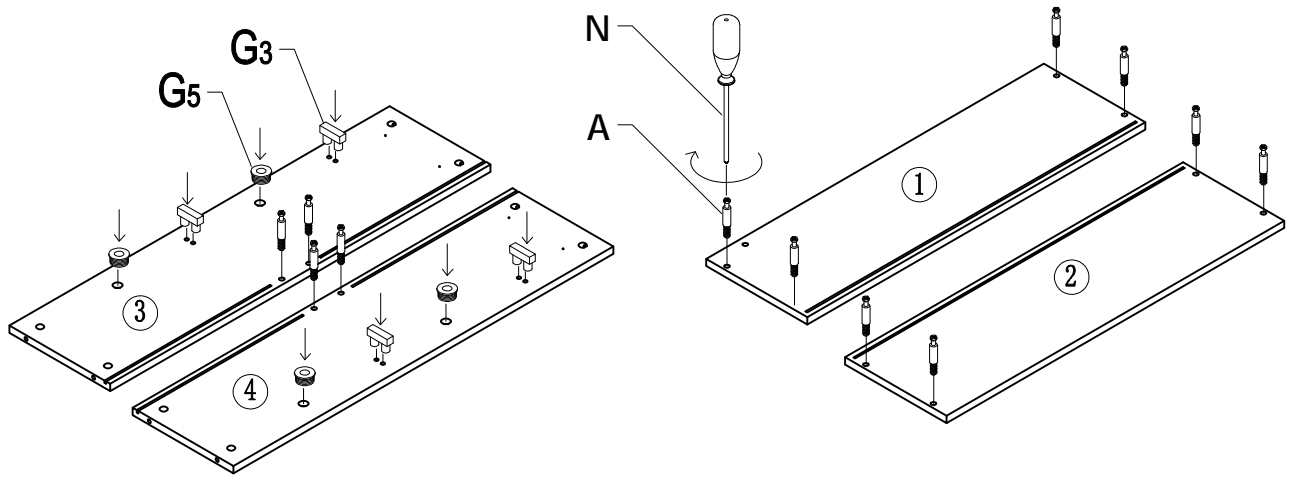

$$G = G_1 + G_2 + 2 \times (G_3 + G_4 + G_5)$$

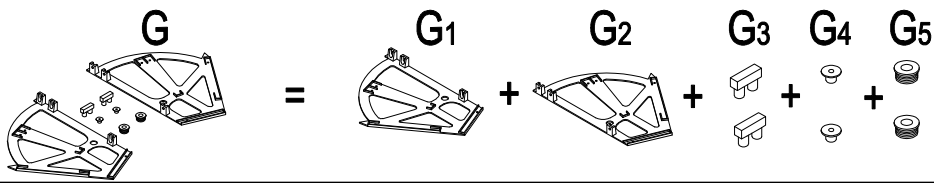

Step 2

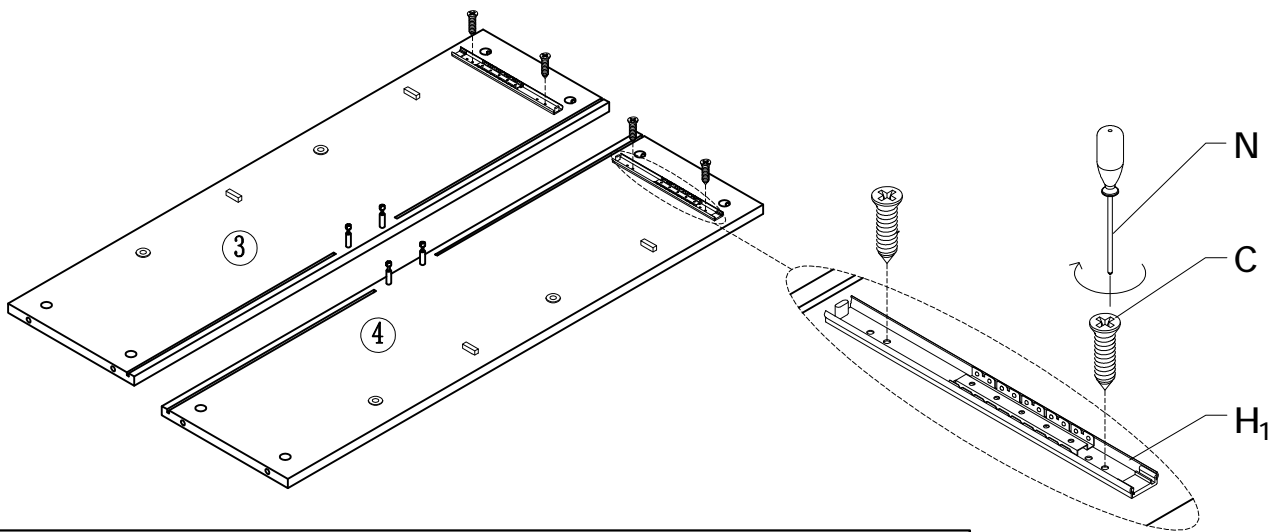

Nx1Pc	Hx1Pc	Cx4Pcs

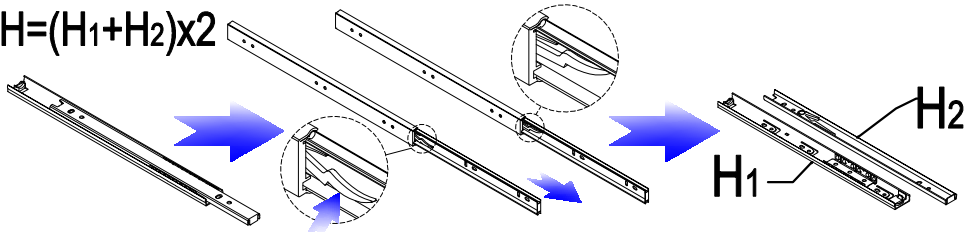

$$H = (H_1 + H_2) \times 2$$



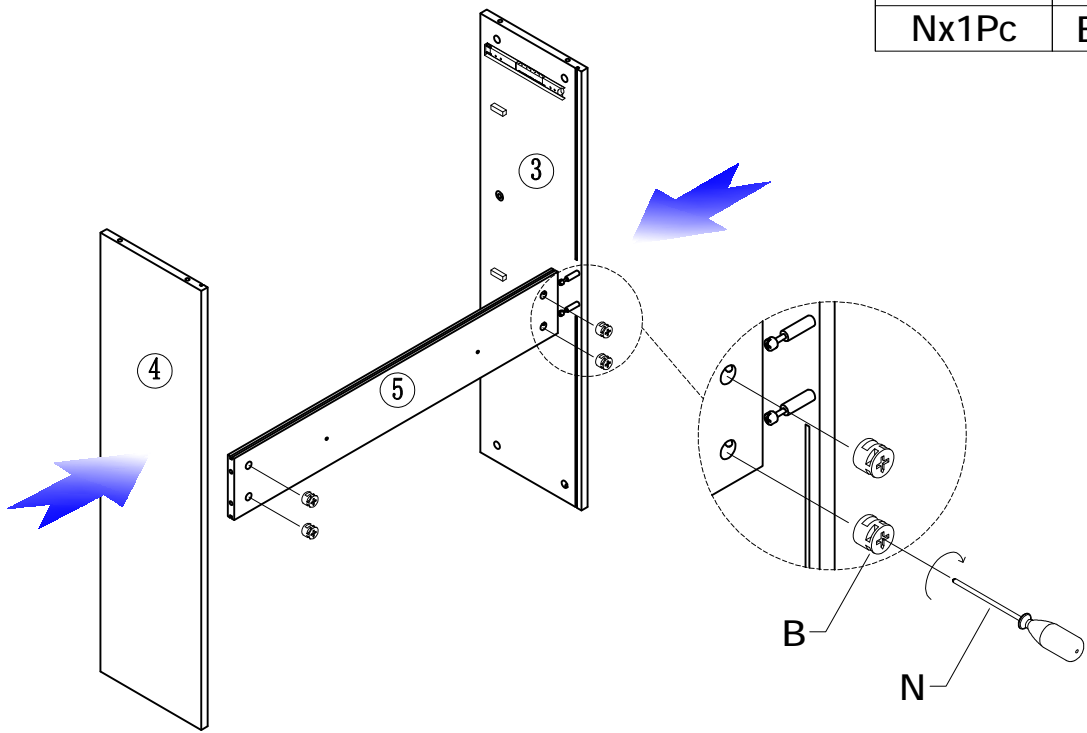

Step 3

	
Nx1Pc	Bx4Pcs



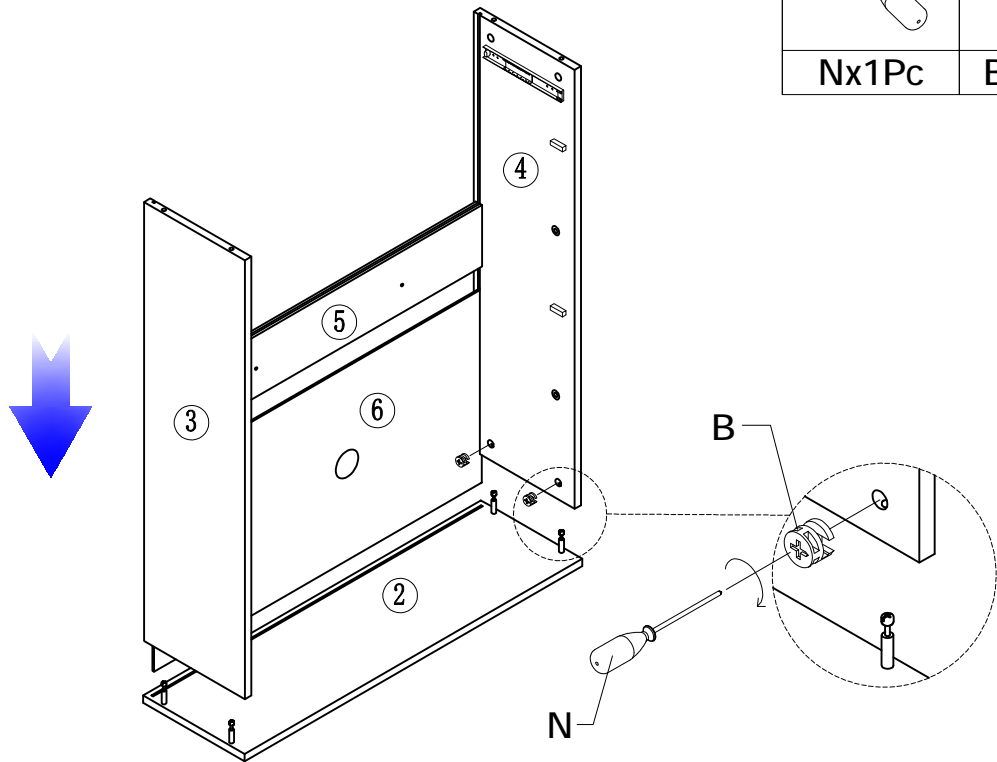

Step 4

	
Nx1Pc	Bx4Pcs

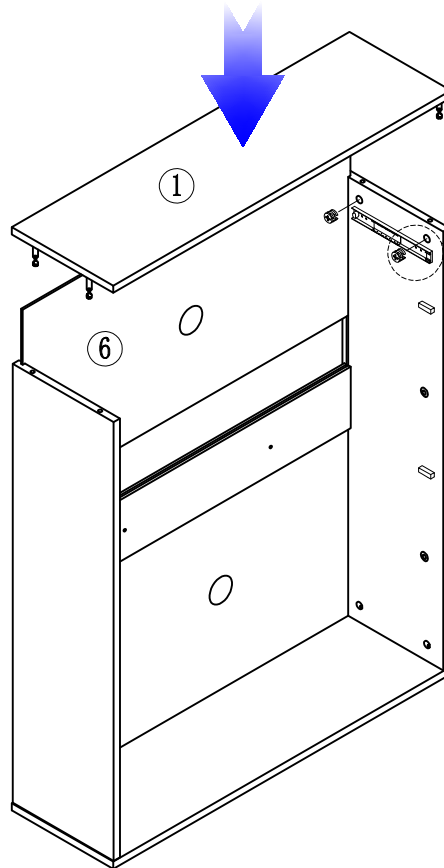

Step 5



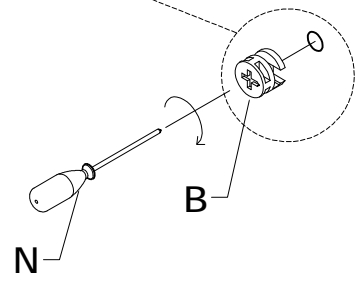

	
Nx1Pc	Bx4Pcs

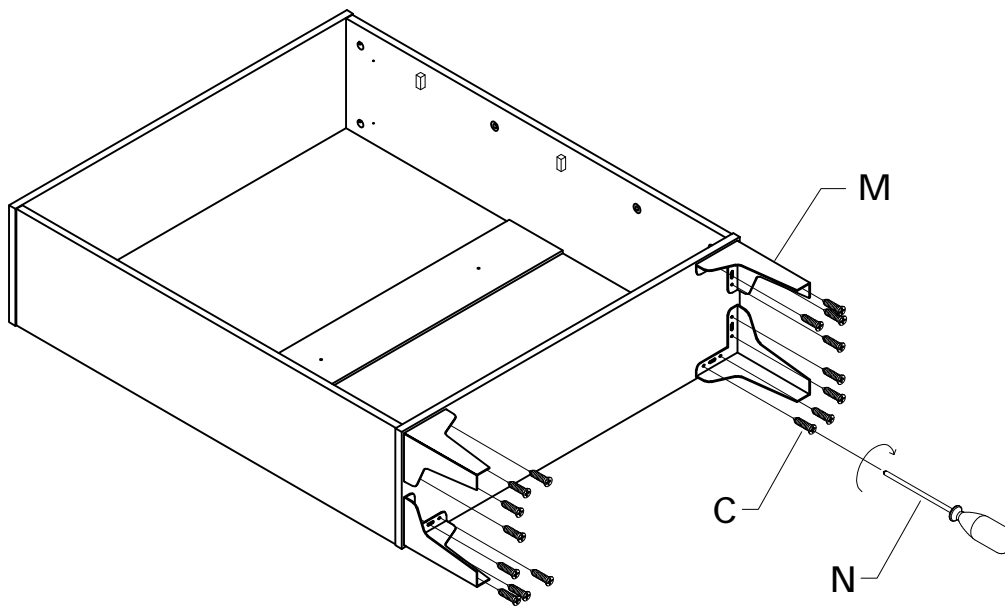

Step 6

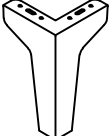

		
Nx1Pc	M4x14 Cx16Pcs	Mx4Pcs

Step 7



Nx1Pc



M4x14

Cx8Pcs



Kx2Pcs



Lx8Pcs

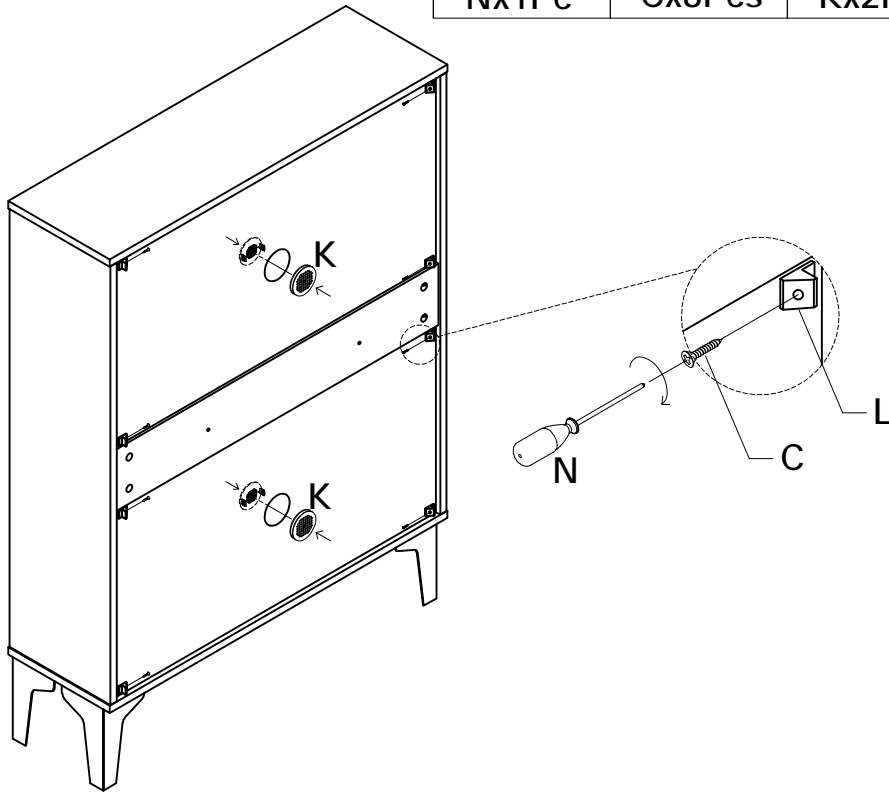

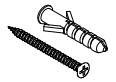

Step 8

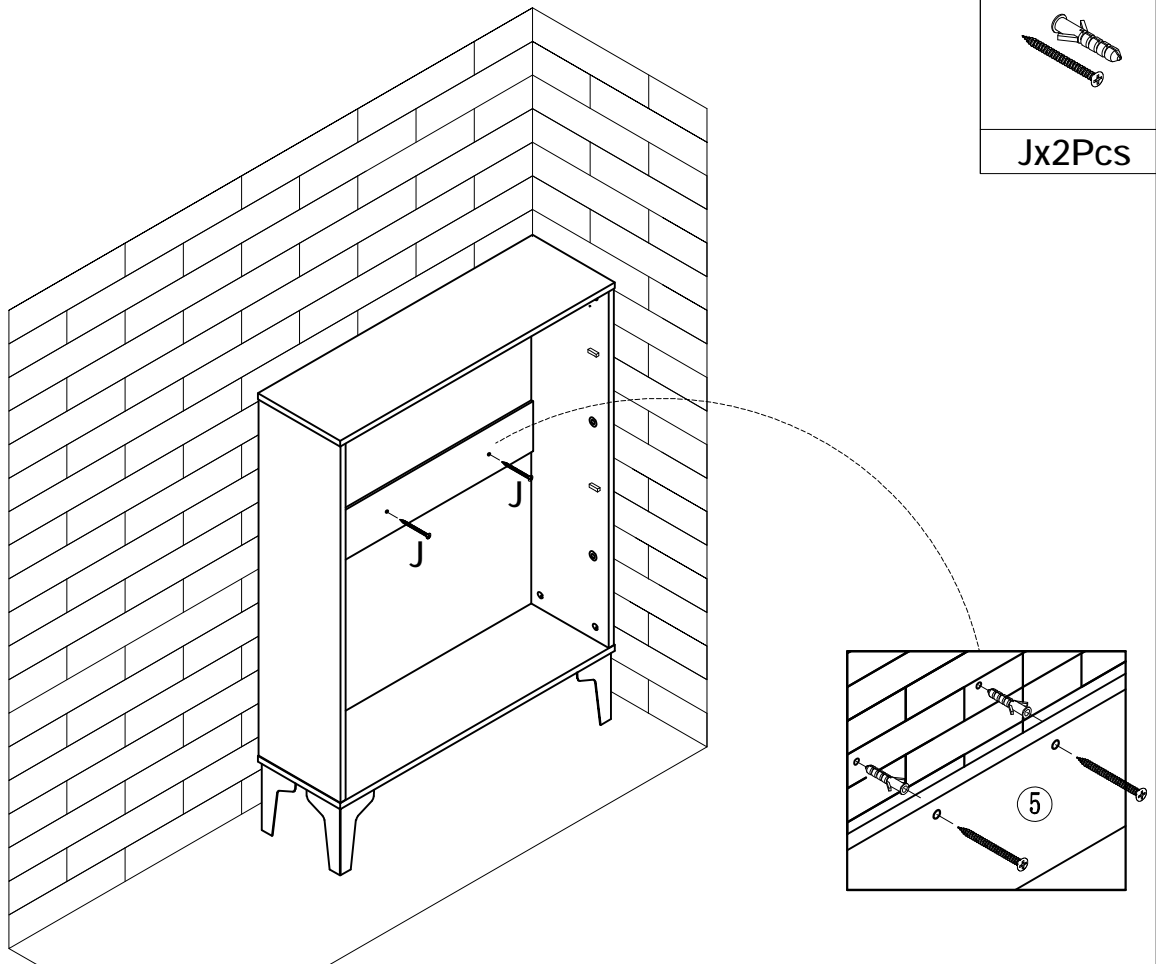

Jx2Pcs



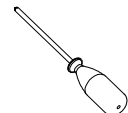
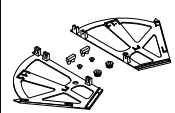

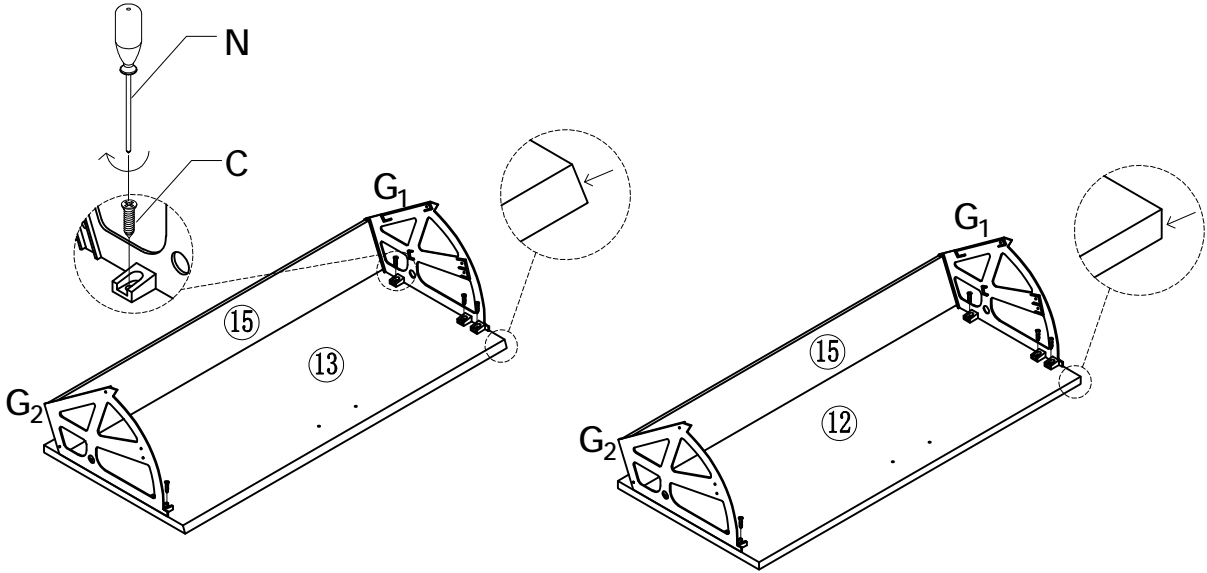

Step 9

		
Nx1Pc	Gx2Pcs	Cx12Pcs



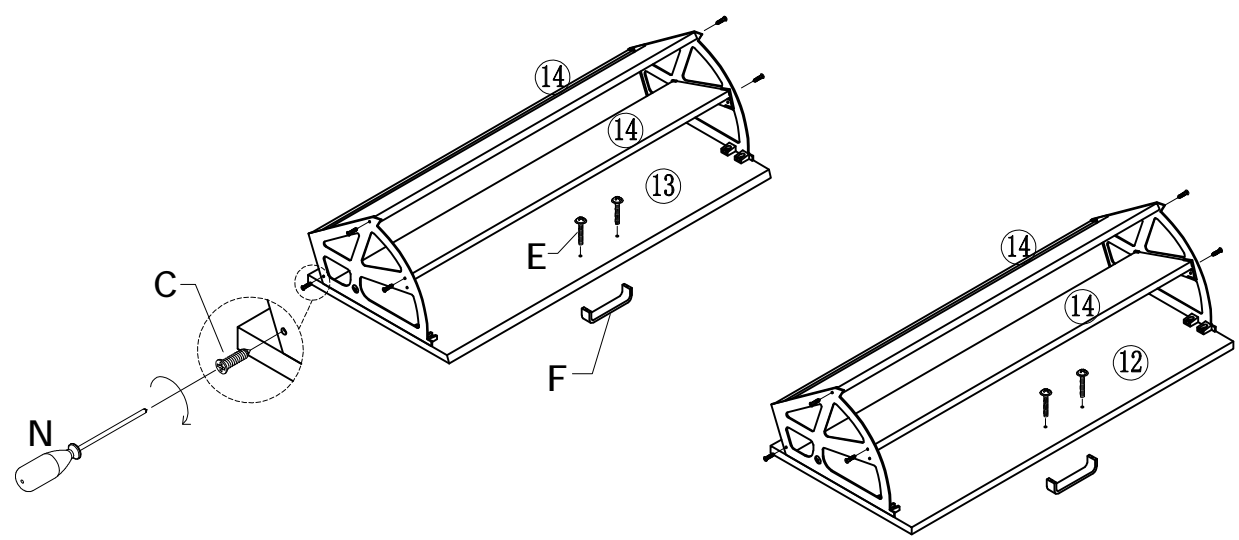

Step 10

			
Nx1Pc	Fx2Pcs	Ex4Pcs	Cx12Pcs



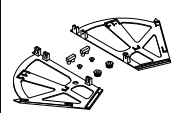

Step 11

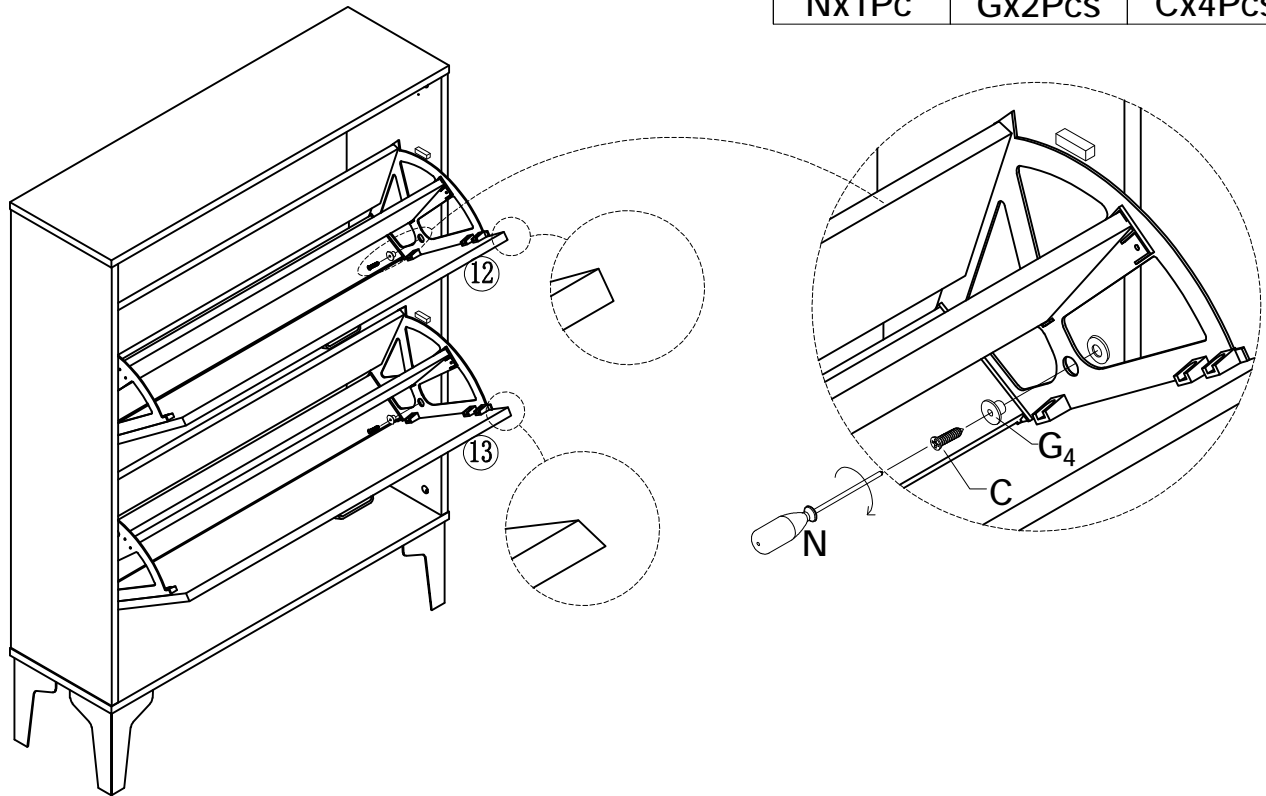
		
Nx1Pc	Gx2Pcs	M4x14 Cx4Pcs



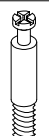
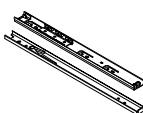

Step 12

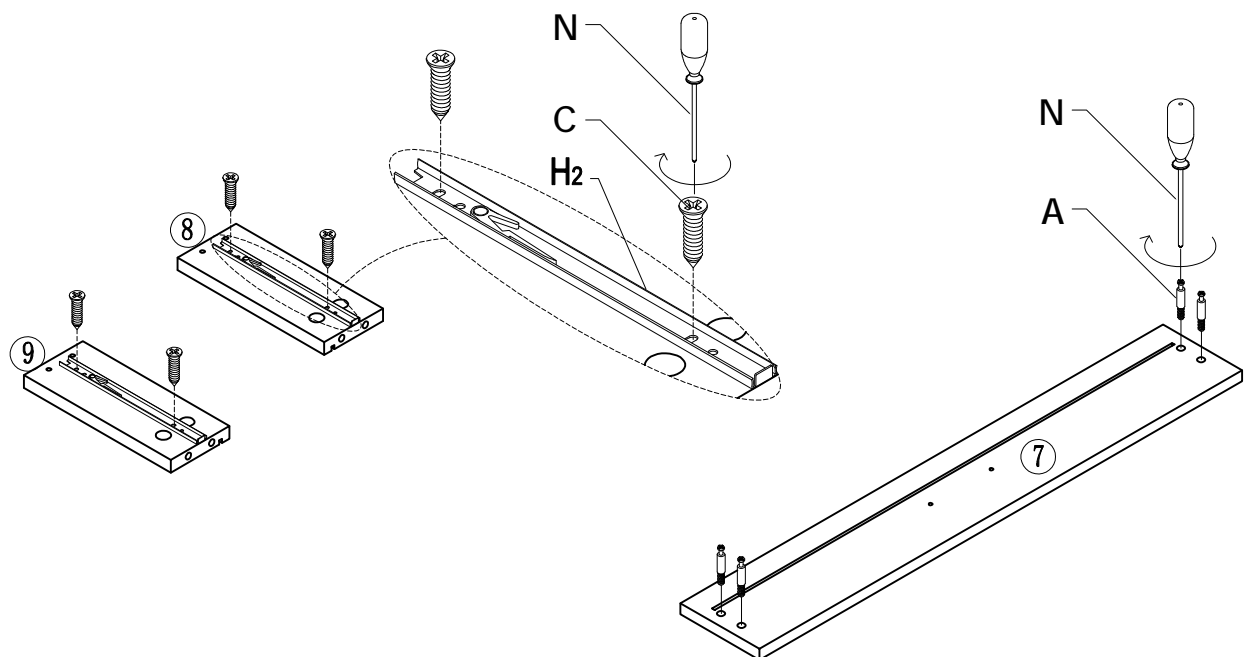
			
Nx1Pc	Ax4Pcs	Hx1Pc	M4x14 Cx4Pcs



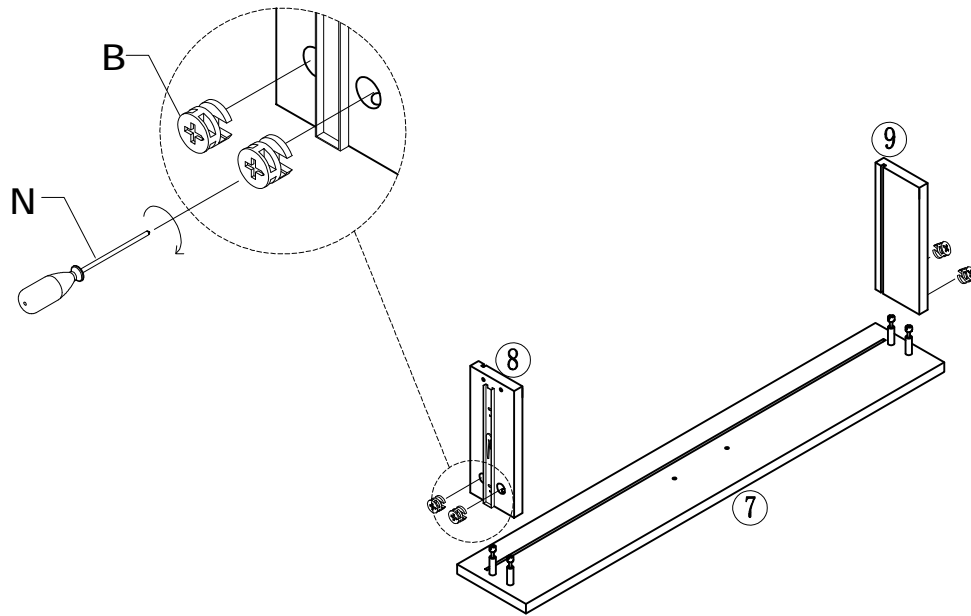

Step 13

	
Nx1Pc	Bx4Pcs



Step 14

	
Nx1Pc	M4x35 Dx4Pcs

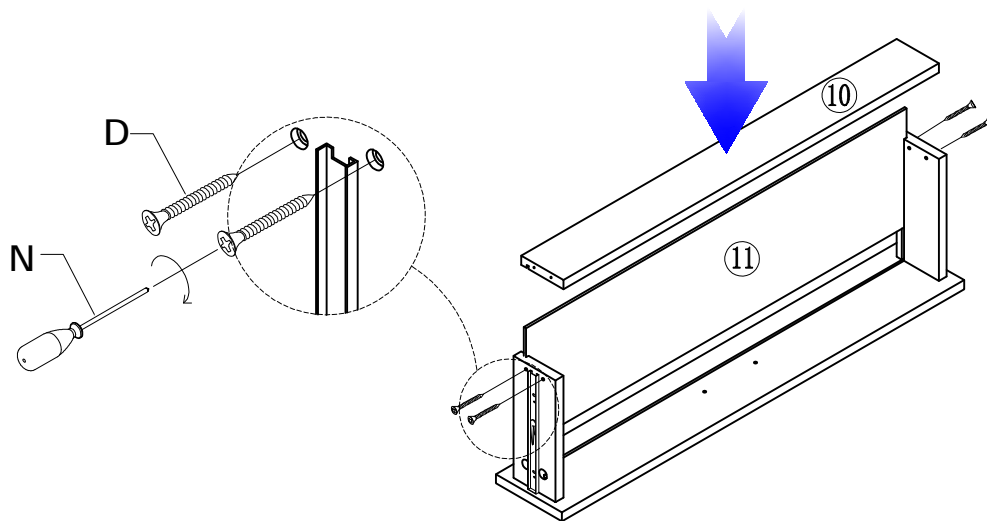

Step 15



Nx1Pc



Fx1Pcs



M4x18
Ex2Pcs

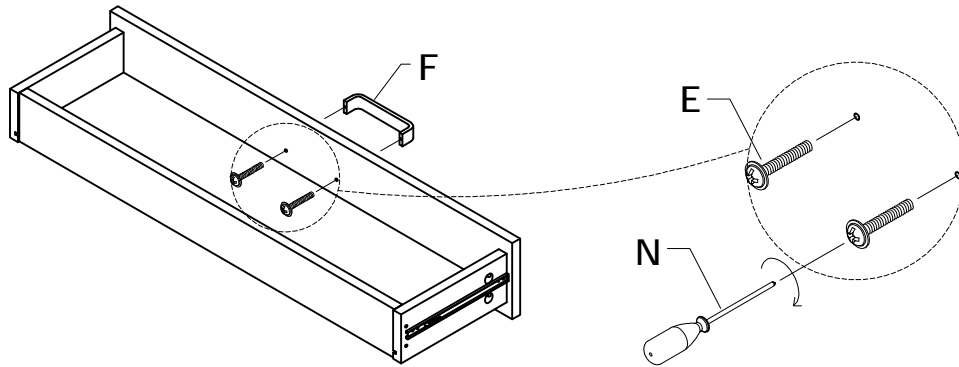

Step 16

