

ASSEMBLY INSTRUCTIONS

Read this instruction carefully. Refer hardware and furniture parts list for guidance. Be sure all parts are complete, before assembling. Place all wooden furniture part on a clean and flat soft surface to prevent scratches. Refer steps provided as assembling guide.

CAUTIONS :

1. Do not **FULLY-TIGHTEN** the nuts or nut bolts until all are in place.
2. To prevent thread damage. Ensure that nuts or nut bolts are not over-tighten.
3. Hardware are to be kept out of reach from children.

PART LIST			HARDWARE LIST		
ITEM	DESCRIPTION	QTY	ITEM	DESCRIPTION	QTY
A	TABLE TOP	1 PC	1	JCBC SCREW M6 x 40mm	4 PCS
B	TABLE LEG	4 PCS	2	SPRING WASHER 1/4"	4 PCS
C	TABLE LEG SUPPORT	1 PC	3	HEX NUT 5/16 x 11	8 PCS
D	TABLE LEG SUPPORT TOP	1 PC	4	SPRING WASHER 5/16"	8 PCS
			5	FLAT WASHER 5/16"	8 PCS
			6	ALLEN KEY (BALL SHAPE) LONG	1 PC
			7	12.8 SPANNER	1 PC
			8	BASE GLIDE C99	4 PCS
			9	WOOD DOWEL DIA 8 x 30MM	2 PCS

STEP 1

REMARK :
DO NOT TIGHTEN FULLY.

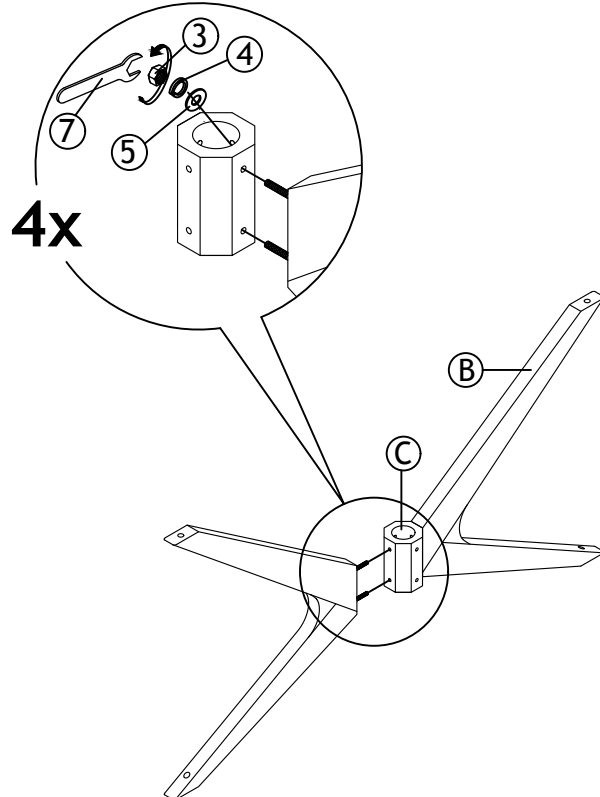

STEP 2

REMARK :
DO NOT TIGHTEN FULLY.

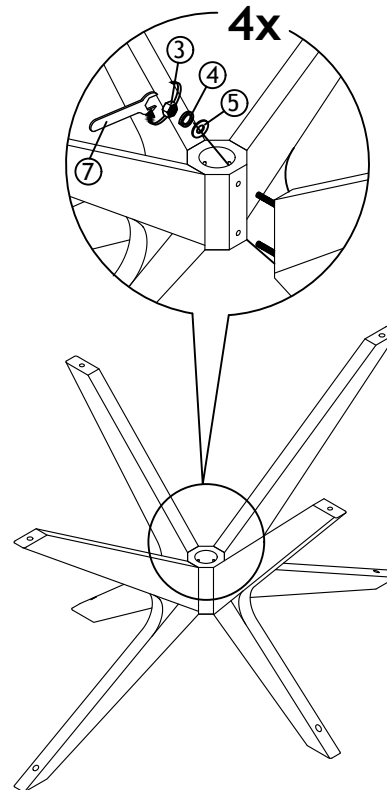

STEP 3

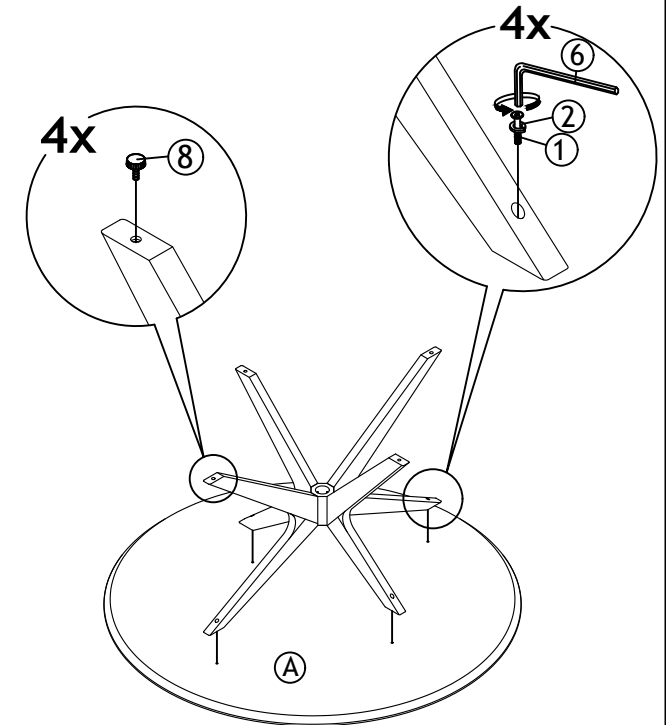

ASSEMBLY INSTRUCTIONS

Read this instruction carefully. Refer hardware and furniture parts list for guidance. Be sure all parts are complete, before assembling. Place all wooden furniture part on a clean and flat soft surface to prevent scratches. Refer steps provided as assembling guide.

CAUTIONS :

1. Do not **FULLY-TIGHTEN** the nuts or nut bolts until all are in place.
2. To prevent thread damage. Ensure that nuts or nut bolts are not over-tighten.
3. Hardware are to be kept out of reach from children.

STEP 4

REMARK :
PLEASE TIGHT IT FULLY.

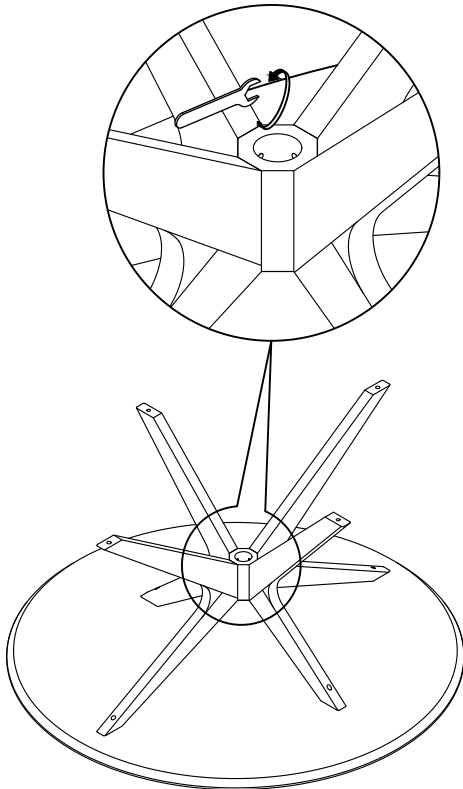

STEP 5

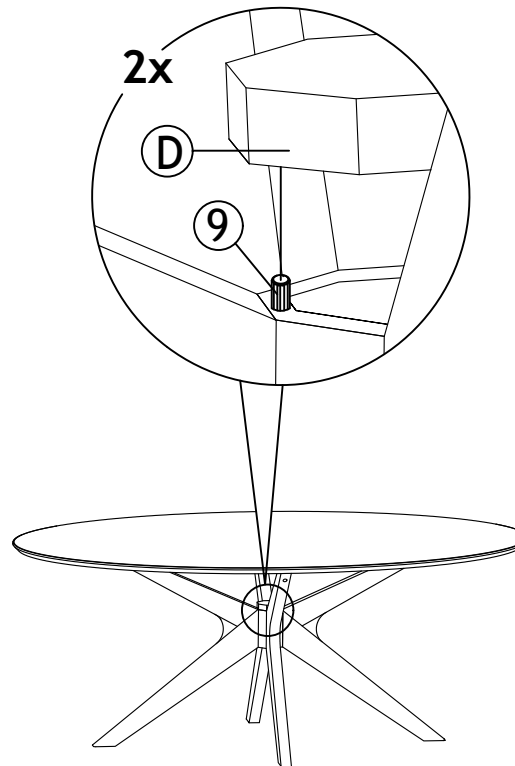

STEP 6

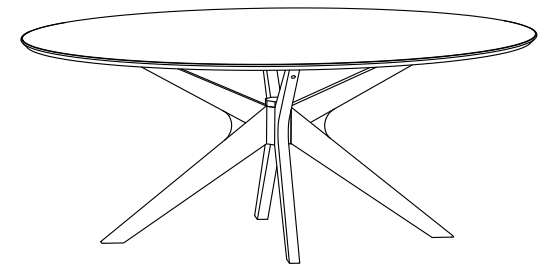

ASSEMBLY COMPLETED