









ASSEMBLY INSTRUCTION

| PARTS LIST | | | |
|------------|---|-----------------|------|
| NO. | PART | DESCRIPTION | QTY |
| 1 |  | STOOL SEAT | 2pcs |
| 2 |  | STOOL LEG | 8pcs |
| 3 |  | LONG STRETCHER | 4pcs |
| 4 |  | SHORT STRETCHER | 4pcs |

| HARDWARE LIST | | | |
|---------------|--|------------------------|-------|
| NO. | PART | DESCRIPTION | QTY |
| A |  | ALLEN BOLT Ø1/4"x 50mm | 8pcs |
| B |  | SPRING WASHER Ø1/4" | 8pcs |
| C |  | FLAT WASHER Ø1/4"x22mm | 8pcs |
| D |  | SCREW 50mm | 16pcs |
| E |  | ALLEN KEY M4 | 2pcs |

STEP : 1 Insert Stretchers (3 & 4) between Stool Legs (2), noting correct orientation of screw holes. Secure Stool Legs (2) to Stool Seat (1) first. Then secure all end of Stretchers (3 & 4) to Stool Legs (2) last.

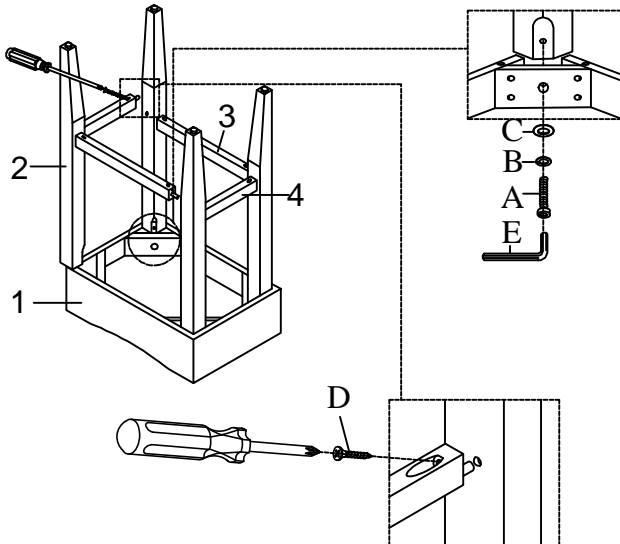

COMPLETED

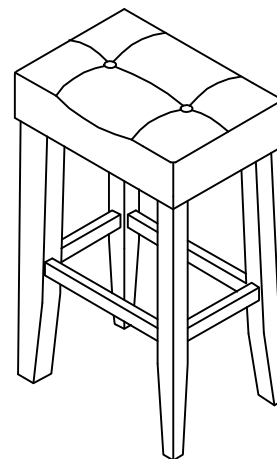

Do not tighten screws until completely assembled.