

INSTRUCTION MANUAL

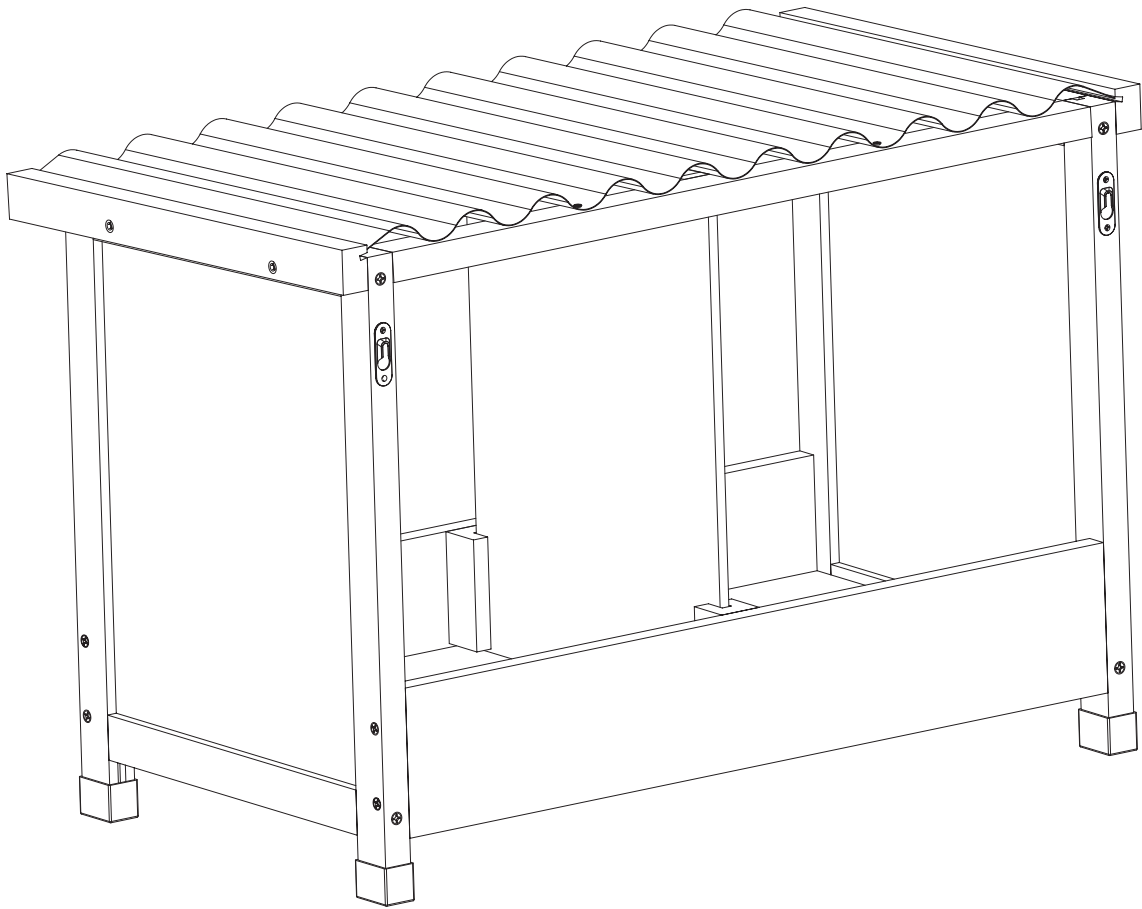

TOOLS REQUIRED



APPROXIMATELY
30MIN. ASSEMBLY



PHILLIPS
SCREWDRIVER

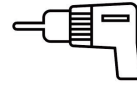

DRILL
(RECOMMENDED)

HARDWARE

M4.5x50mm SCREW
12PCS

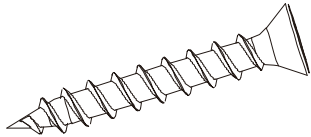

A

M4x40mm SCREW
4PCS

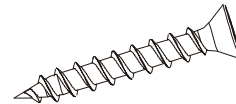

B

M3x18mm SCREW
4PCS

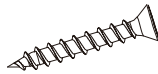

C

PARTS

Left - Panel
1PCS

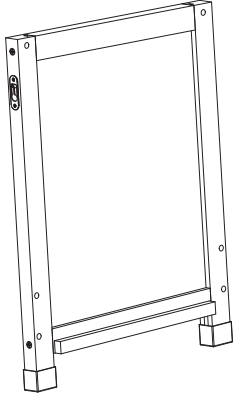

1

Right - Panel
1PCS

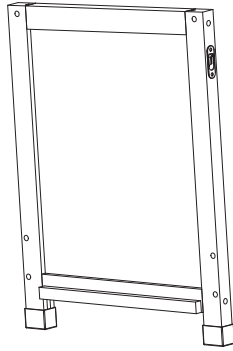

2

Lower - Crossmember
2PCS

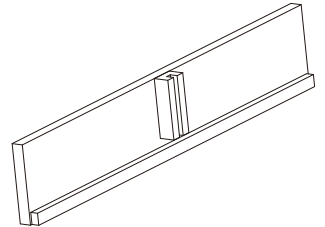

3

Upper - Beam
2PCS

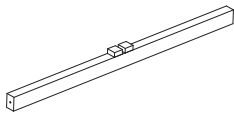

4

Left - Roofing Batten
1PCS

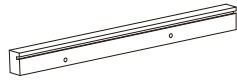

5

Right - Roofing Batten
1PCS



6

Partition
1PCS

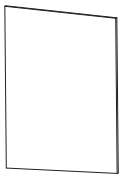

7

Base Plate
1PCS

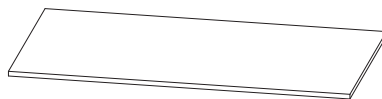

8

Roof surface
1PCS

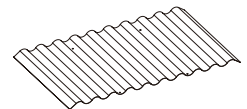

9



Left.

Back

Front

Right

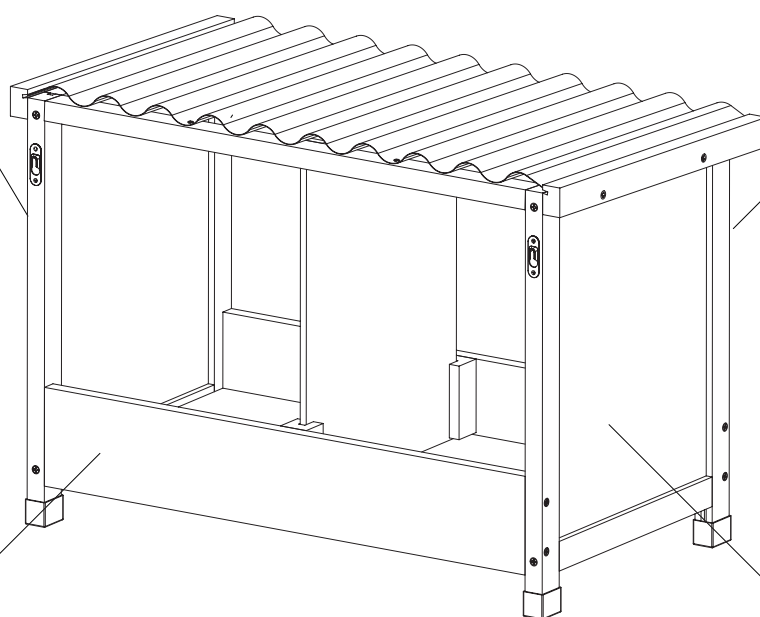

PRODUCT BREAKDOWN DIAGRAM

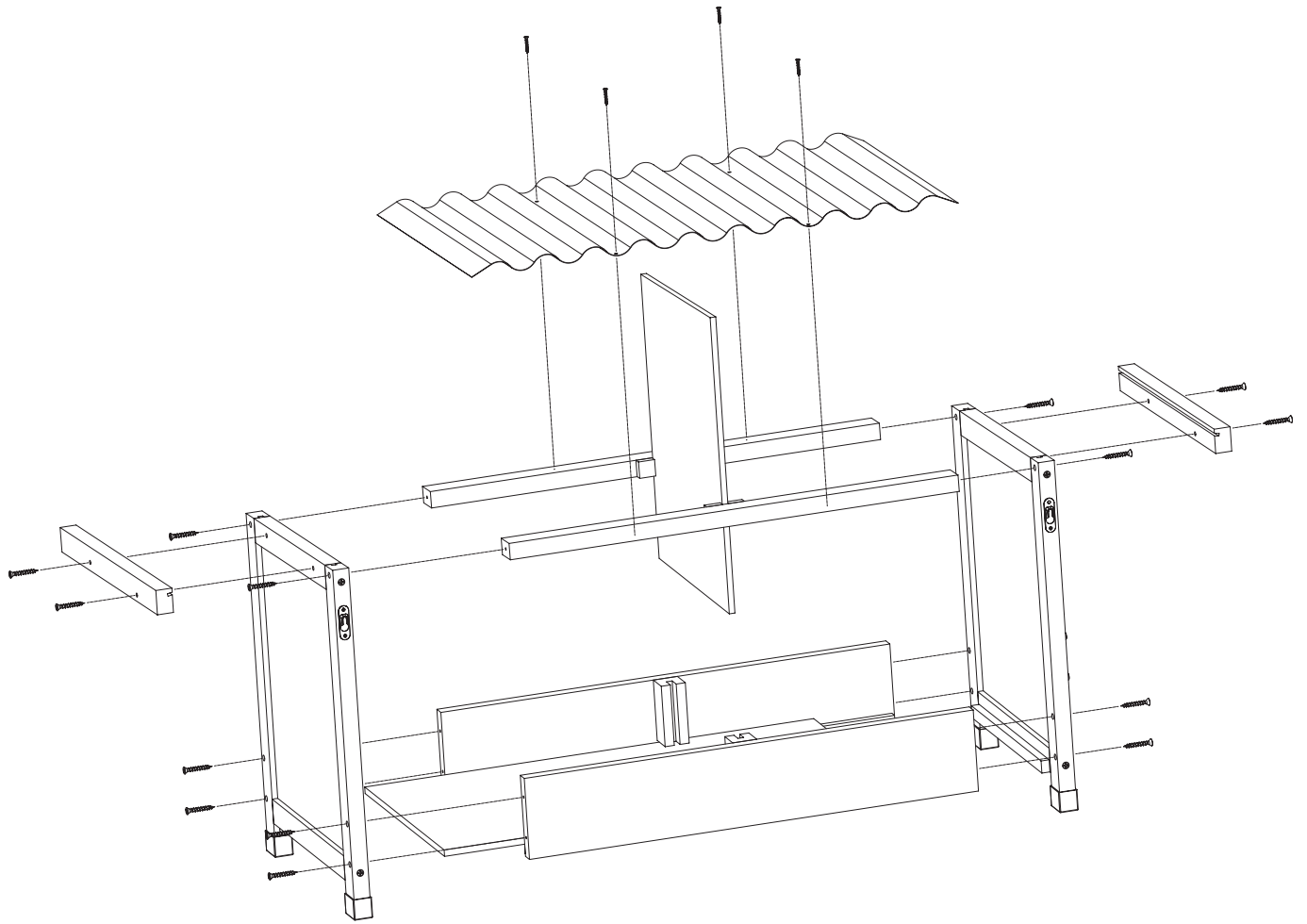

PRODUCT ASSEMBLY

STEP-1: Use (A) screws to connect component (1), component (3), and component (4).

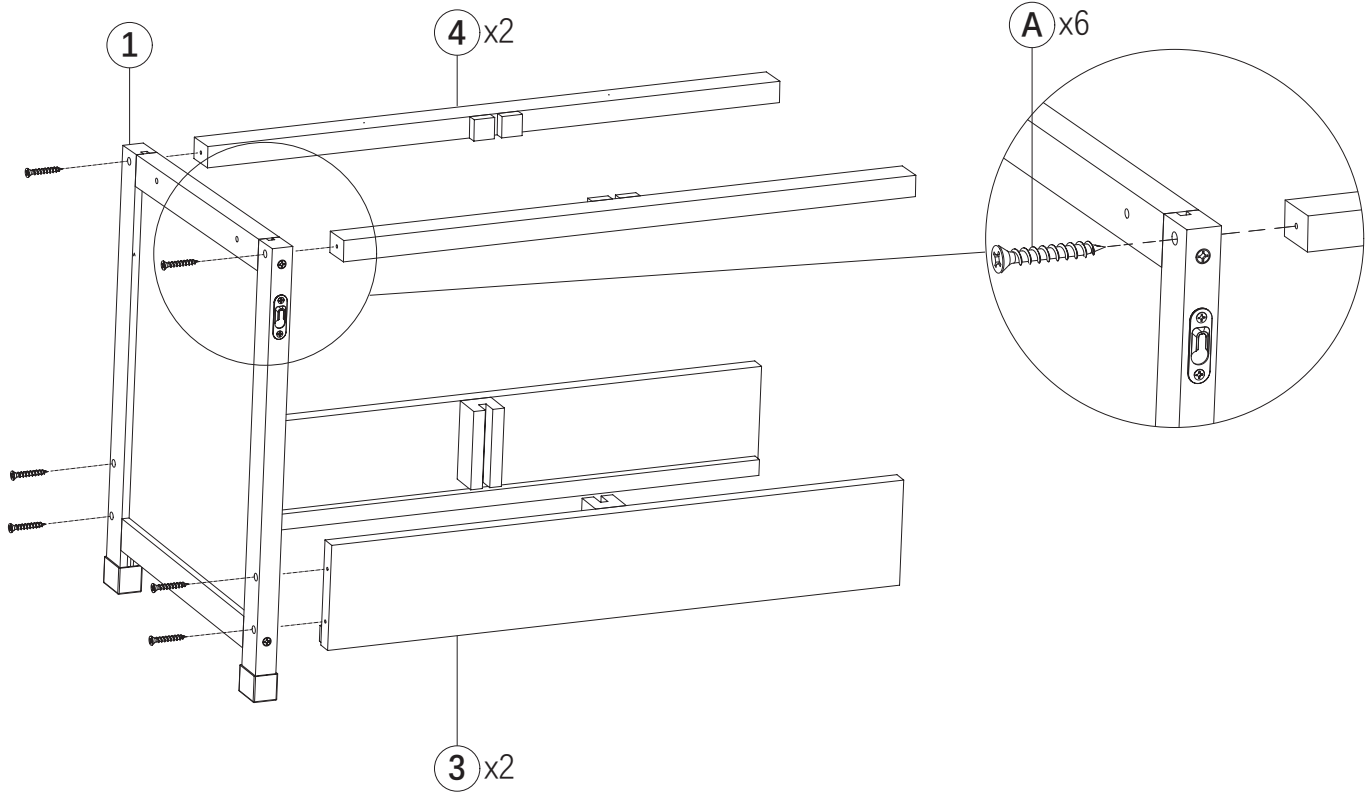

STEP-2: Place part (8) in the indicated position, then use (A) screws to connect part (2) to step 1.

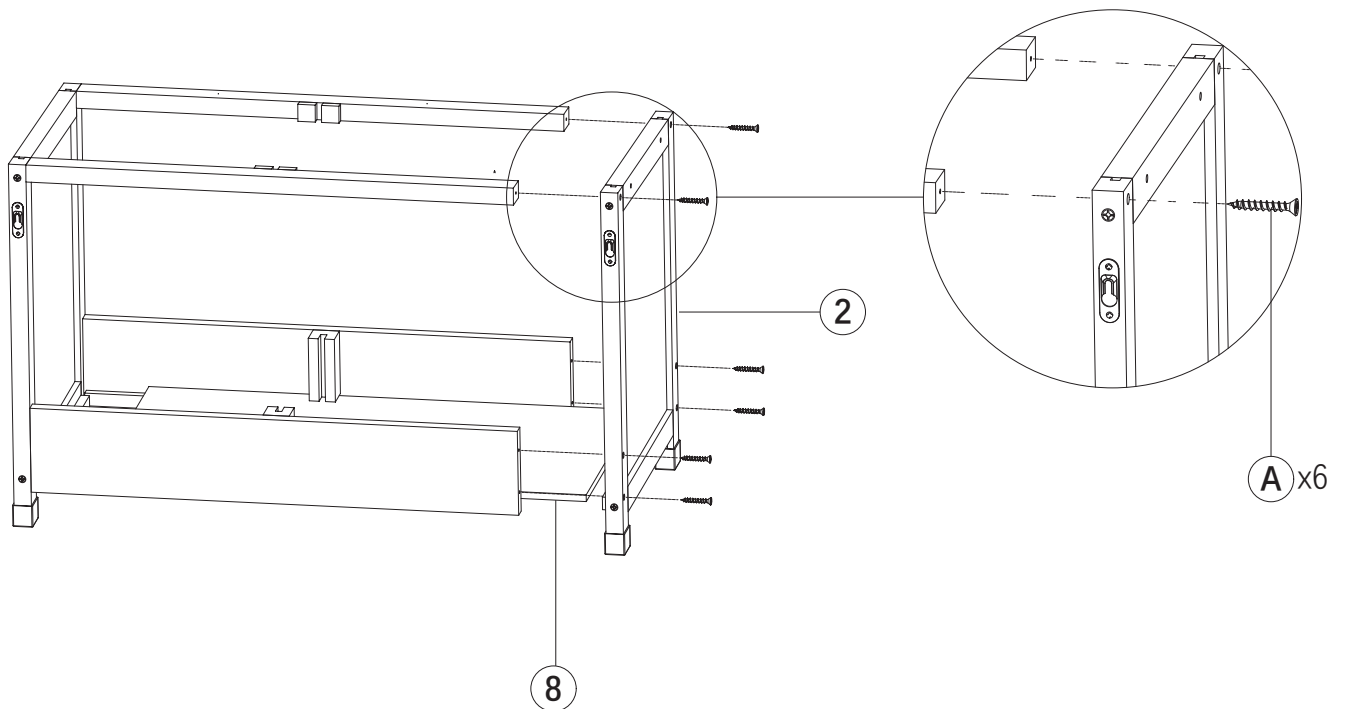

PRODUCT ASSEMBLY

STEP-3: Use **B** screws to connect part **5** and part **6**, then place part **7** in the designated position

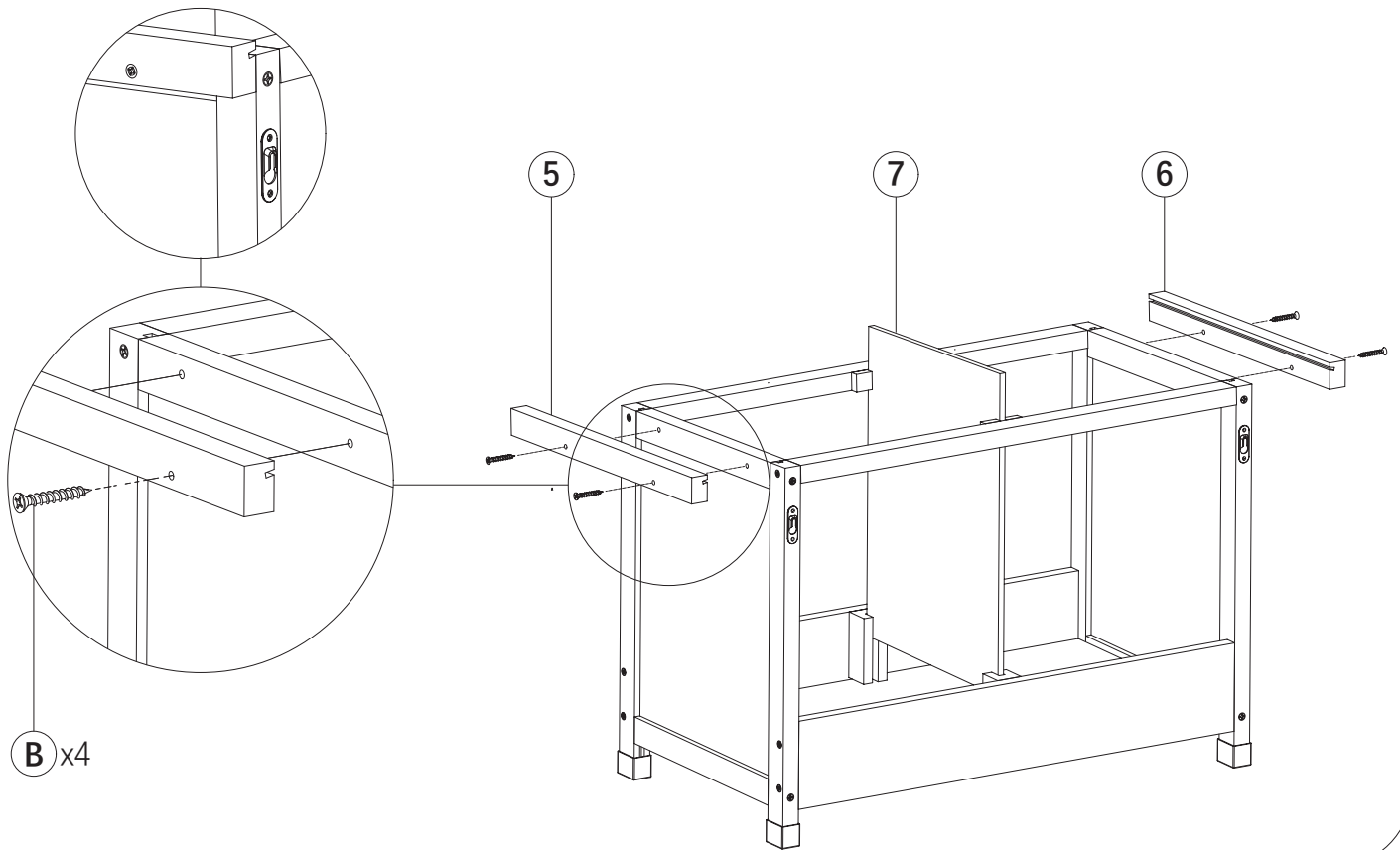

STEP-4: Place part **9** in the designated position, then secure it with **C** screws.

