

DA60-76 / DA72-76

INSTALLATION MANUAL

BIFOLD SHOWER DOOR

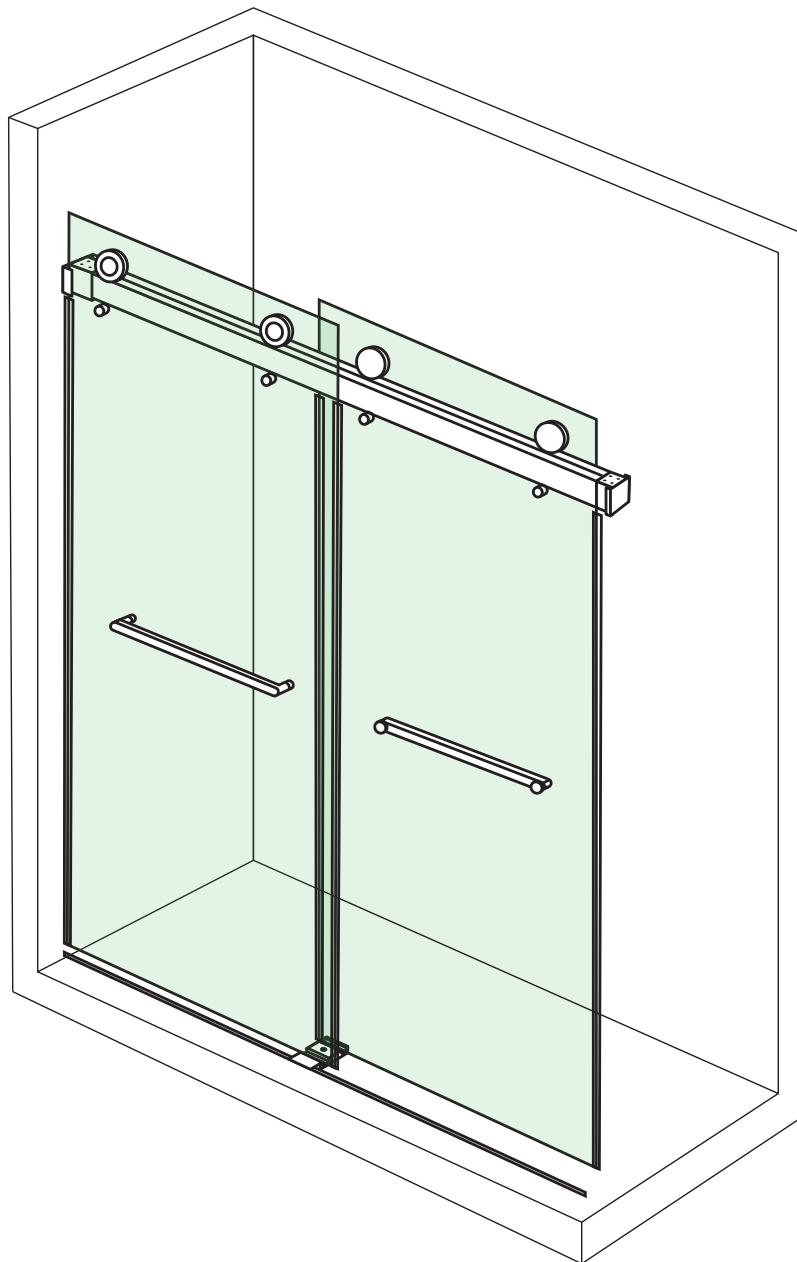

THANK YOU!

Dear Valued Customer,

Thanks to your kind support of BESTGO, we hope our product can improve the quality of your life.

As our valued customer, your comments and opinions are very important to us. If you have any concerns, questions, or comments, we hope that you will bring them to our attention.

Please keep the carton and packaging materials until your product is completely installed.

Feel free to contact us if you encounter any problems such as missing parts, or product defects during the installation process. We are happy to provide you with the most sincere service.

*Sincerely,
BESTGO Service Team*

Product size

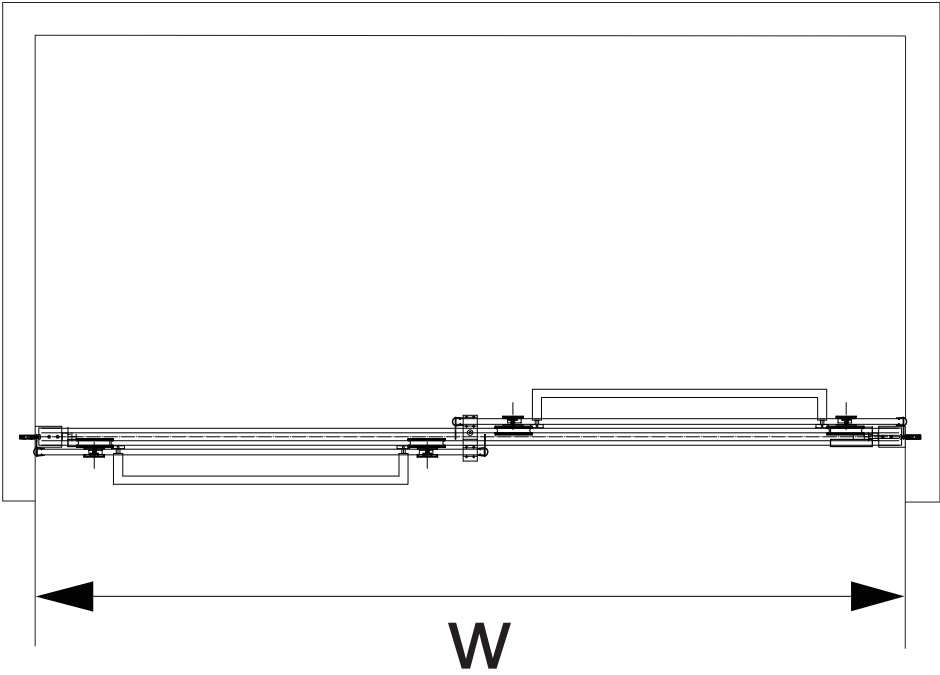

Model	Size	Width		Height
		Min.	Max.	
DA60-76	60"	56"	60"	76"
DA72-76	72"	68"	72"	76"

Pre-installation Tool



IMPORTANT
Please read and follow all warnings and instructions before using this product. Improper use may cause injury. Keep well this guide for long use.

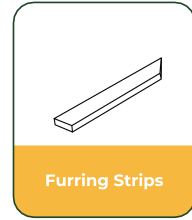
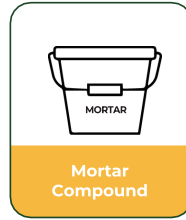
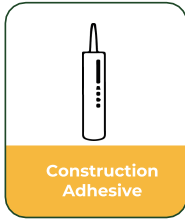
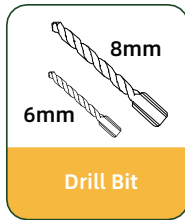
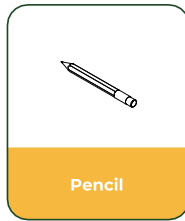
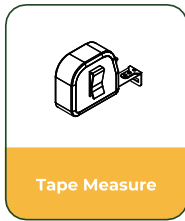
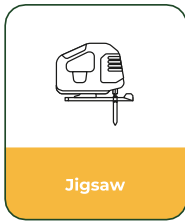
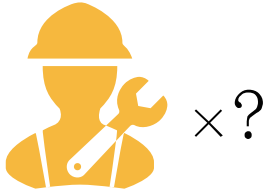

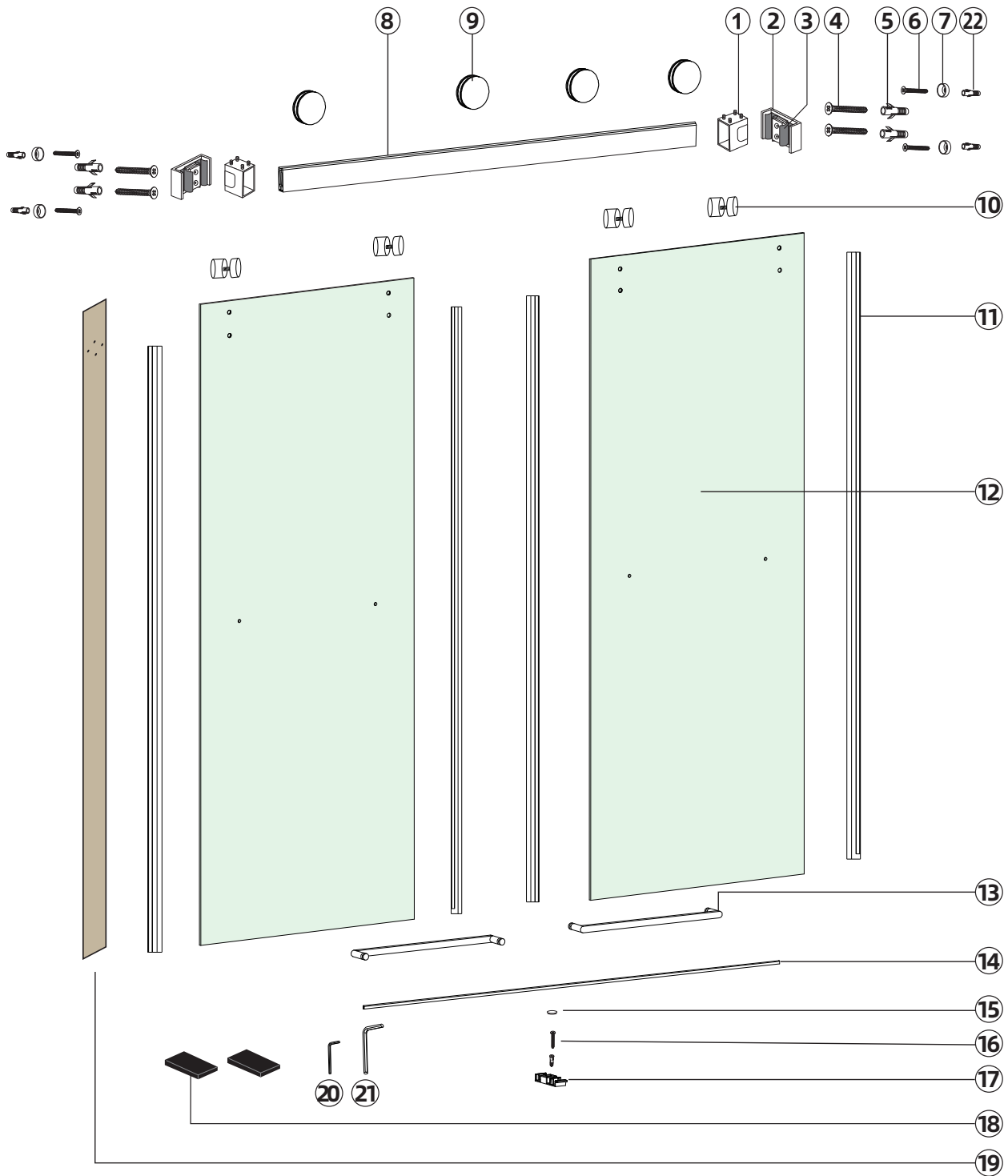

NO.	Picture	Qty	NO.	Picture	Qty	NO.	Picture	Qty	NO.	Picture	Qty	NO.	Picture	Qty
①		x2	②		x2	③		x4	④		x4	⑤		x4
⑥		x4	⑦		x4	⑧		x1	⑨		x4	⑩		x4
⑪		x4	⑫		x2	⑬		x2	⑭		x1	⑮		x1
⑯		x1	⑰		x1	⑱		x2	⑲		x1	⑳		
㉑		x1	㉒		x5									

Identify Vertical and Horizontal Openings

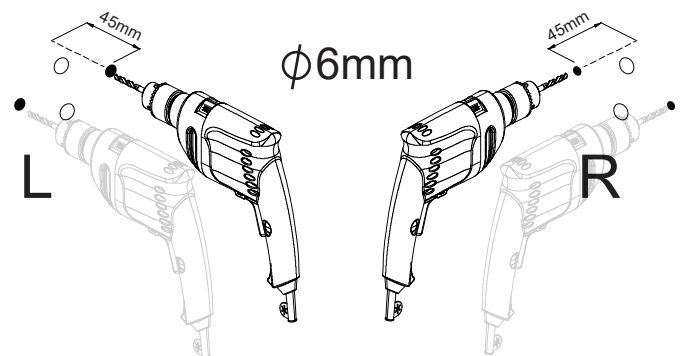
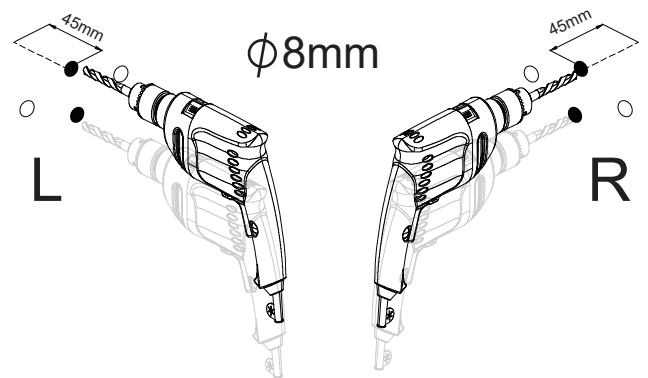
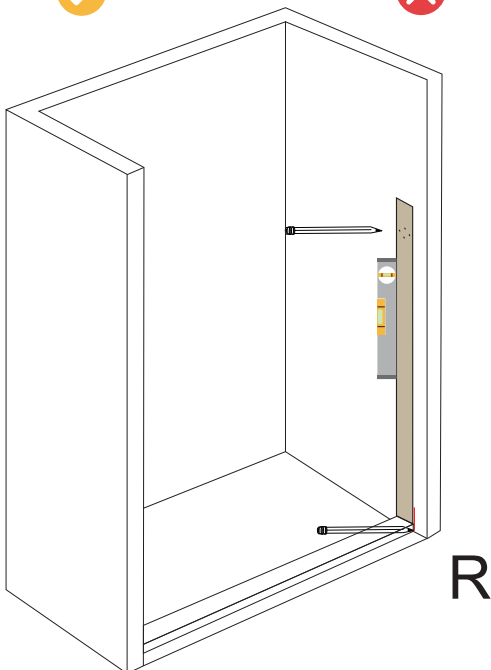
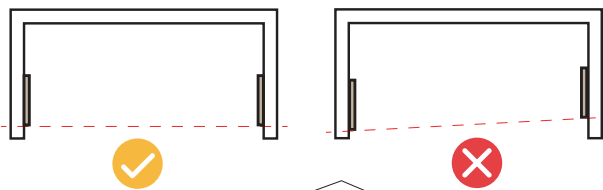
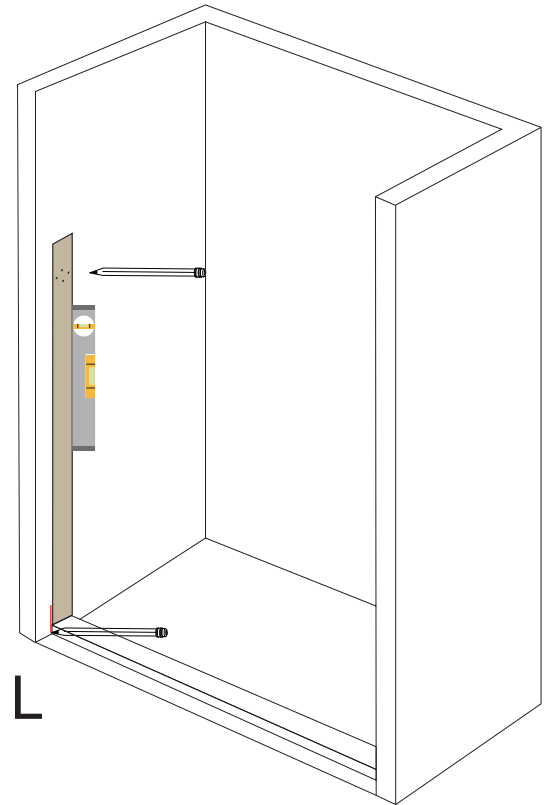
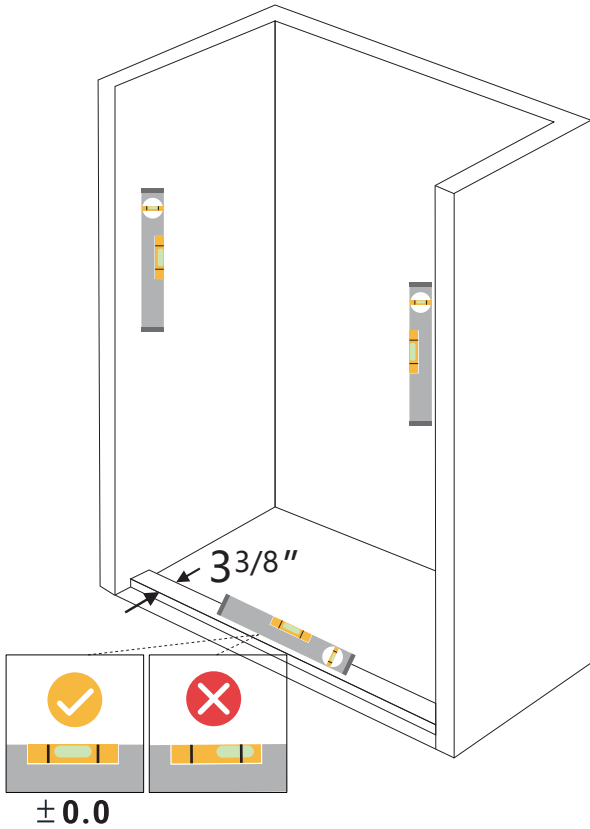

Installation Step 02

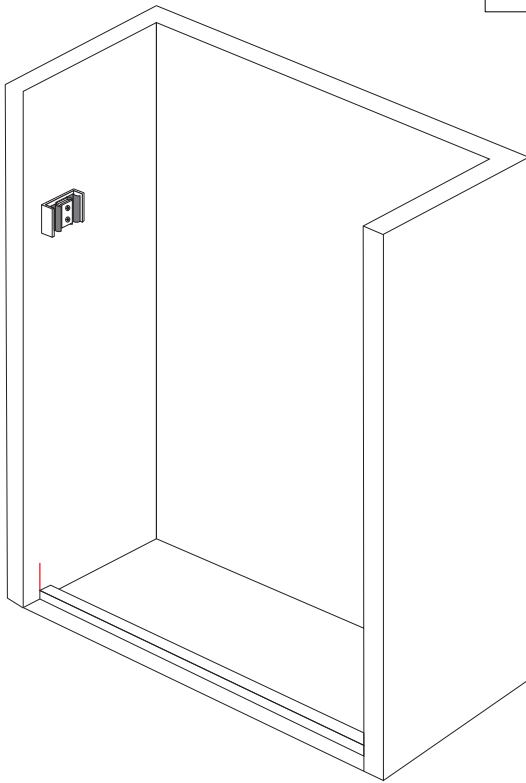
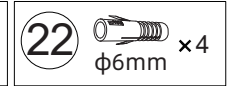
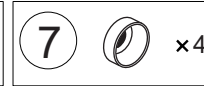
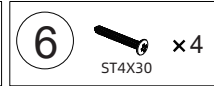
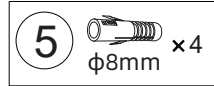
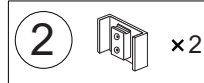

L

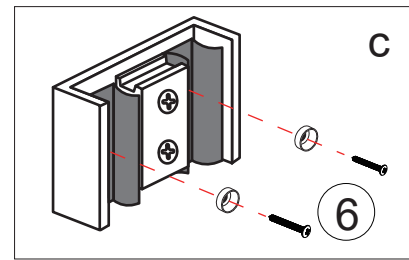
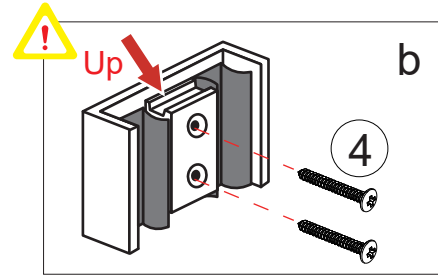
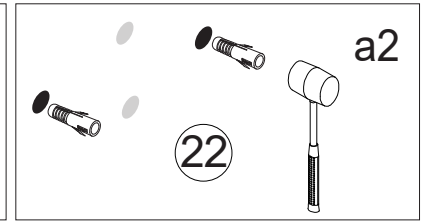
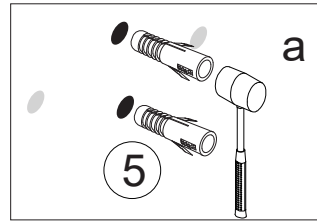

Identify Vertical and Horizontal Before Screw Tightly

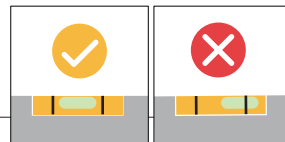
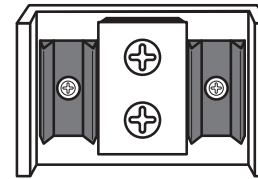
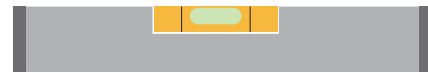
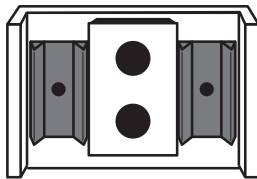
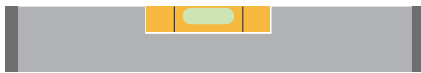

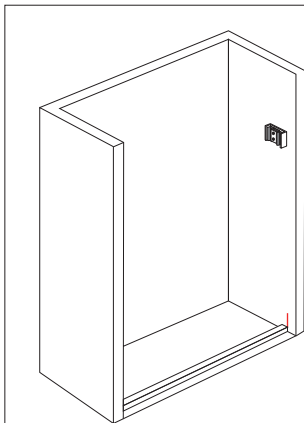

± 0.0

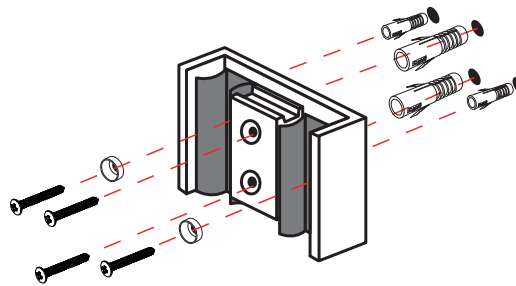

R



Installation Step 03

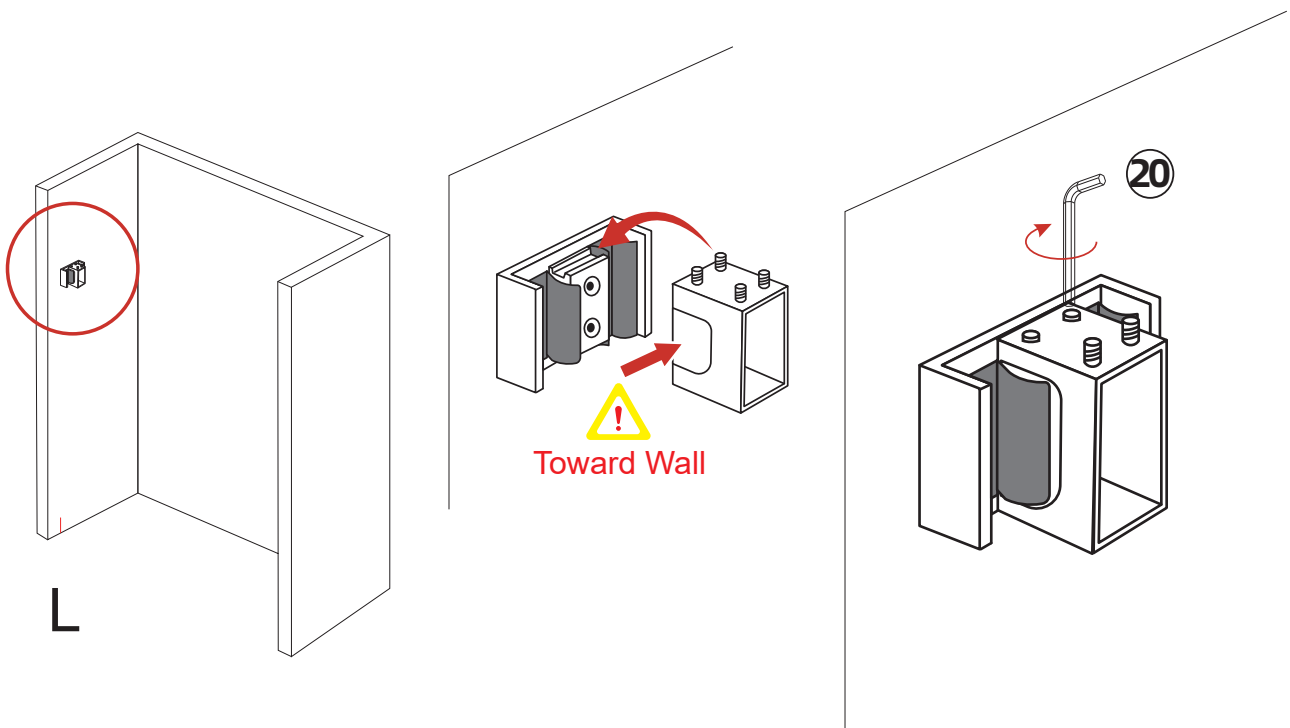
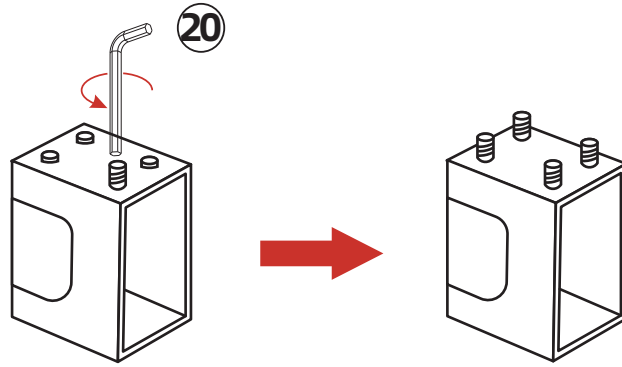

1		x2	20		3mm
---	---	----	----	---	-----

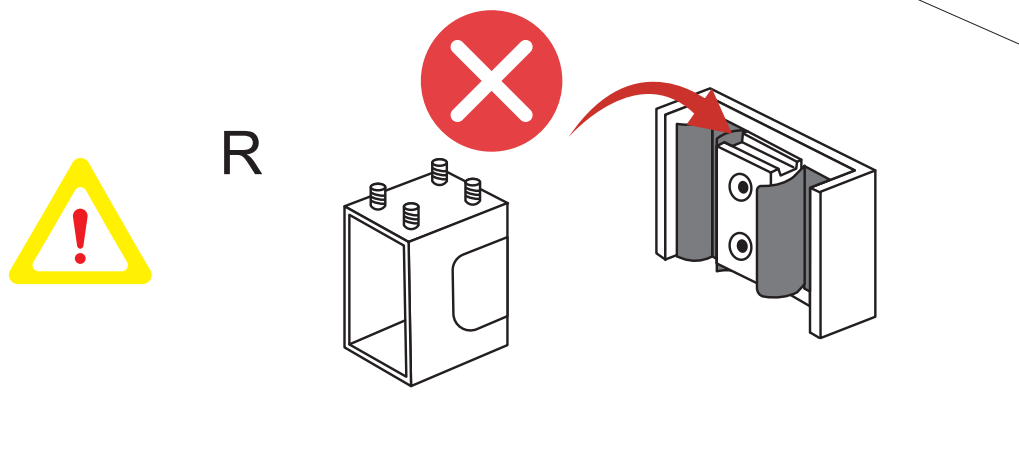

Install One-Side Wall Connector Only



Installation Step 04

- 8  x1
- 1  x1
- 20  3mm

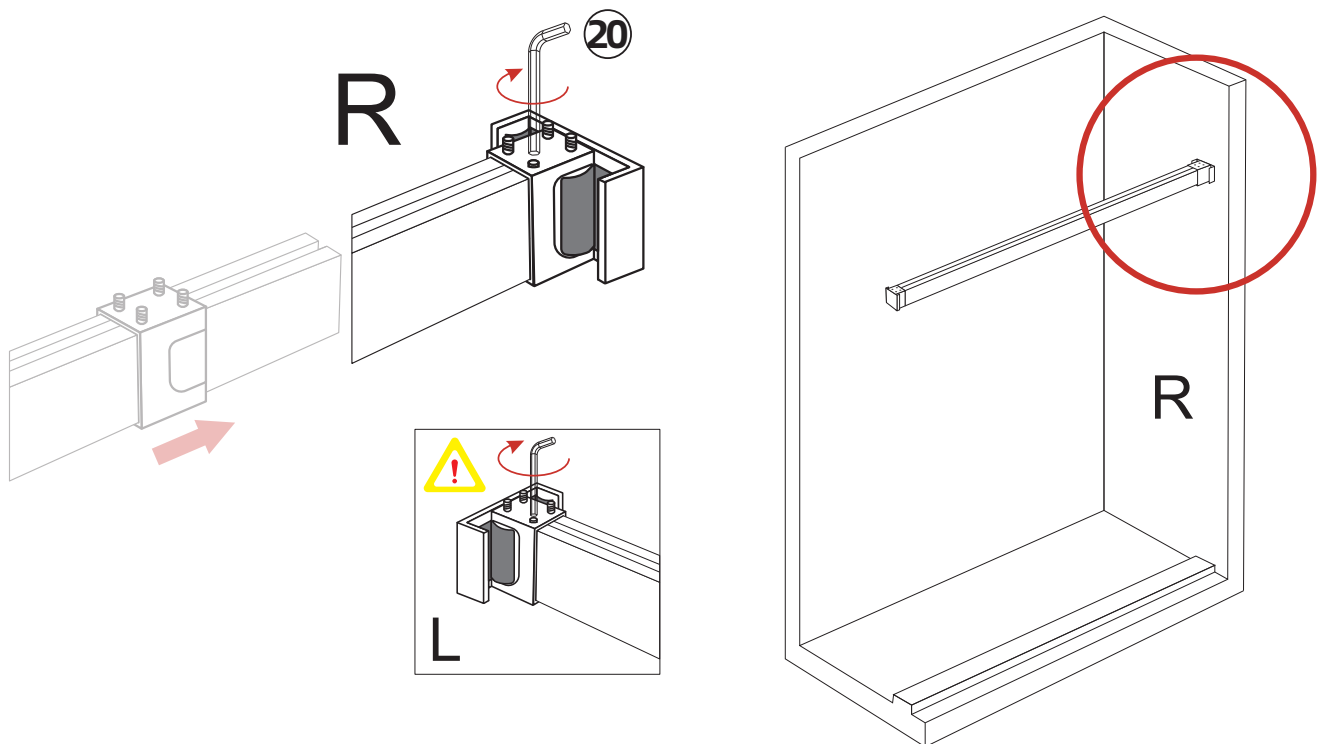
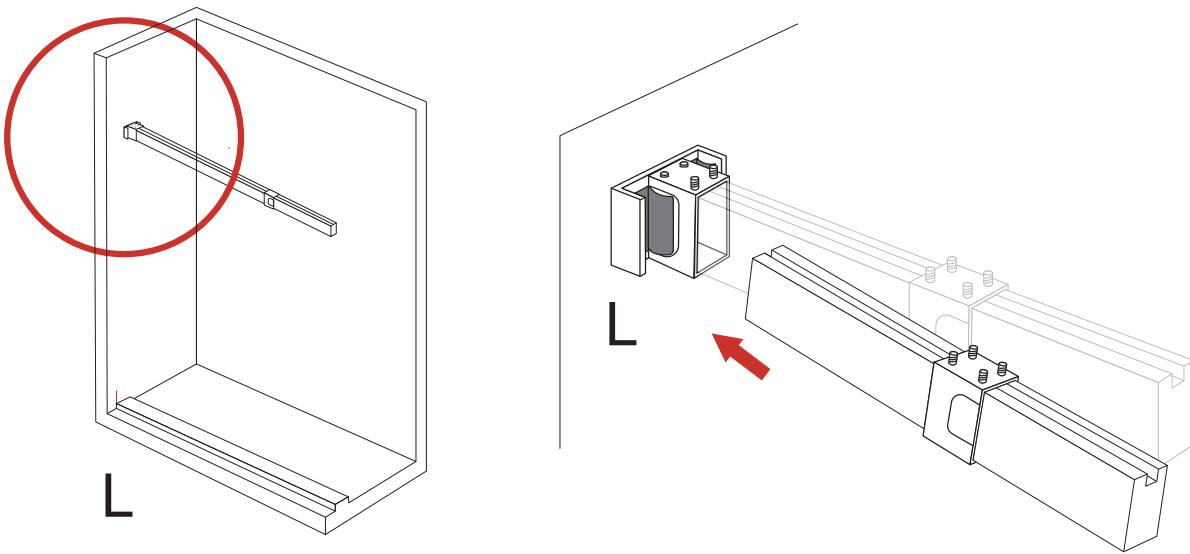
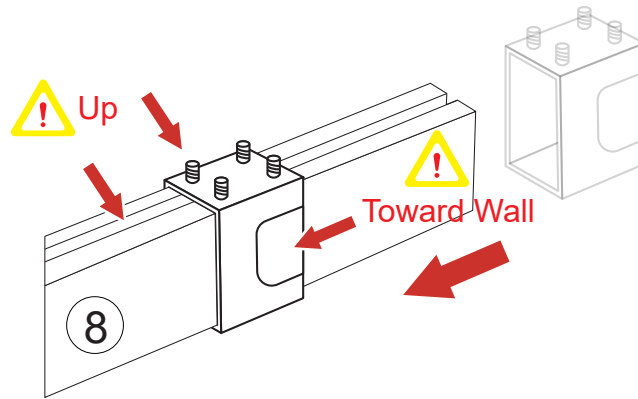

Installation Step 05

22  x1

14  x1

15  x1

16  ST4X40 x1

17  x1



The Guide Should be in the Middle

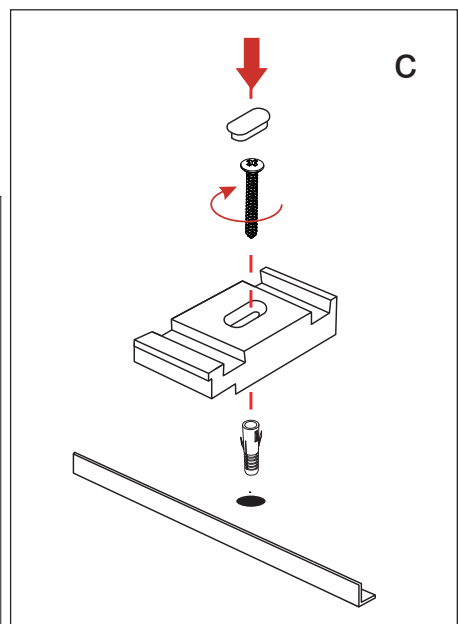
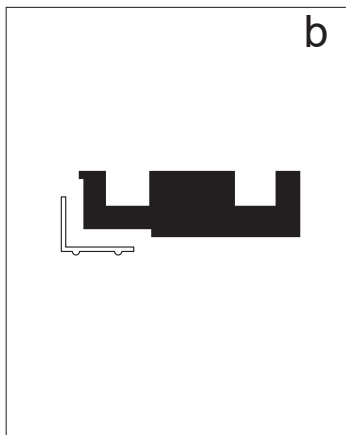
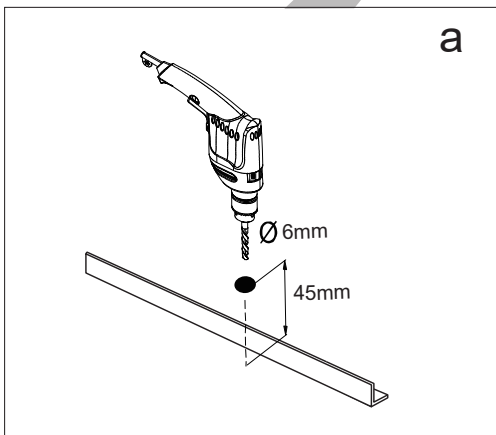
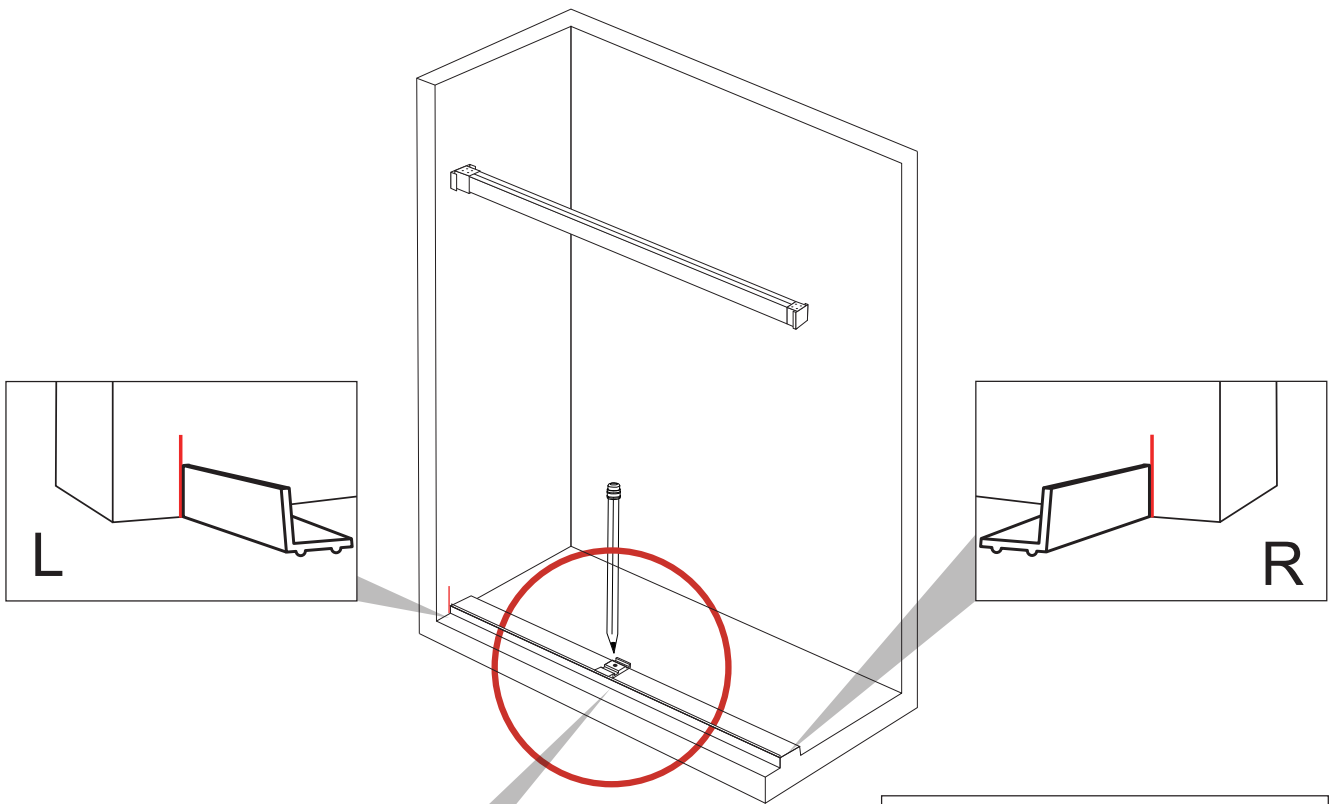
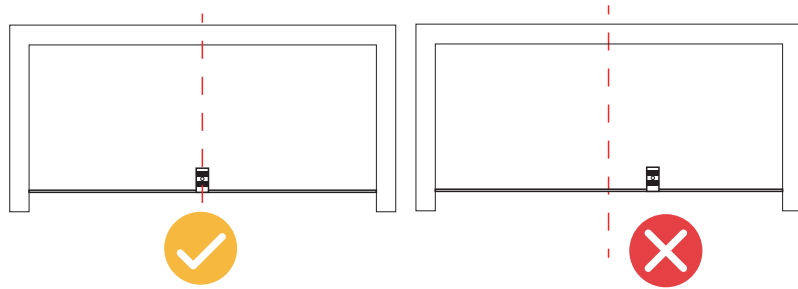

Installation Step 06

12  x2

4  x4

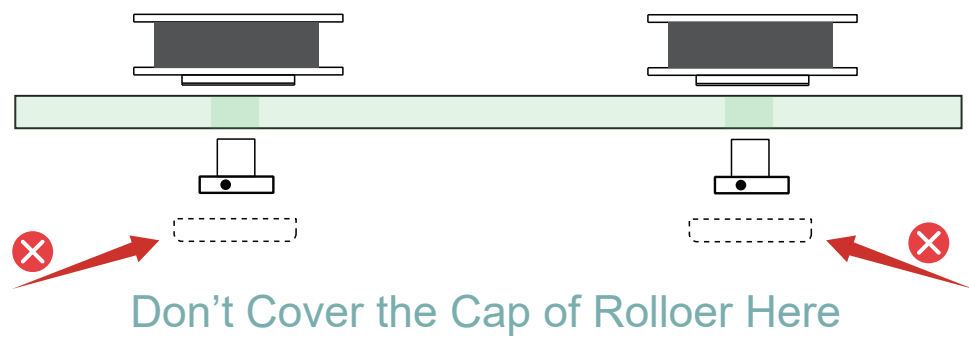
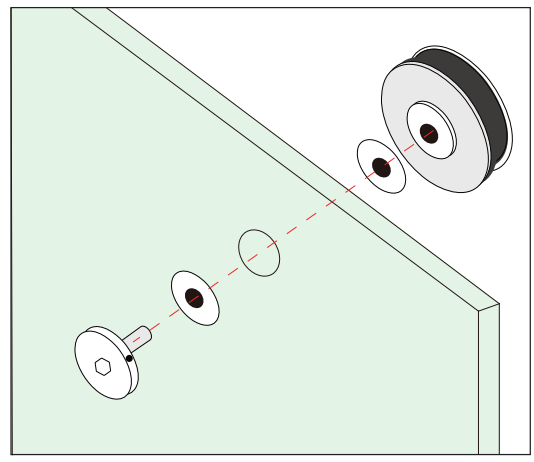
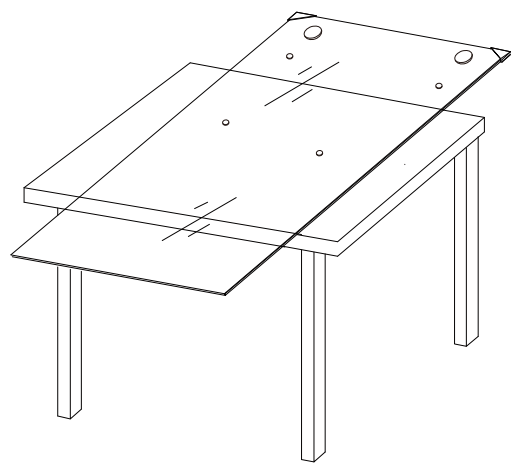

Installation Step 07

18  x2

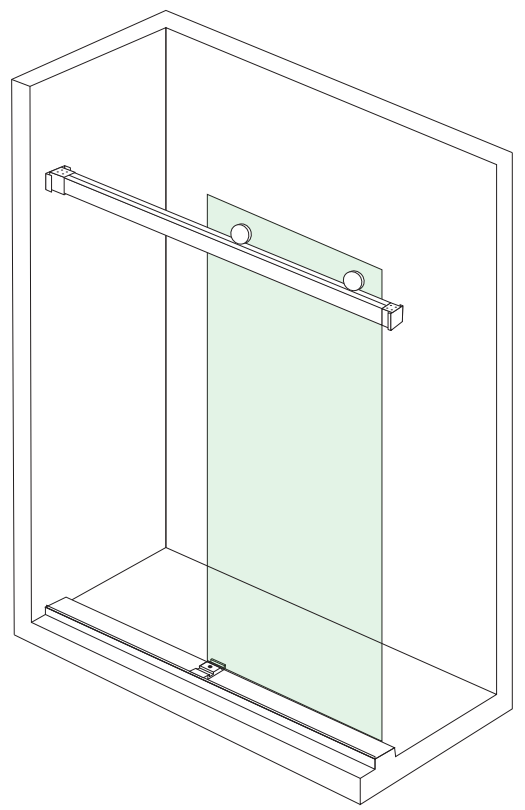
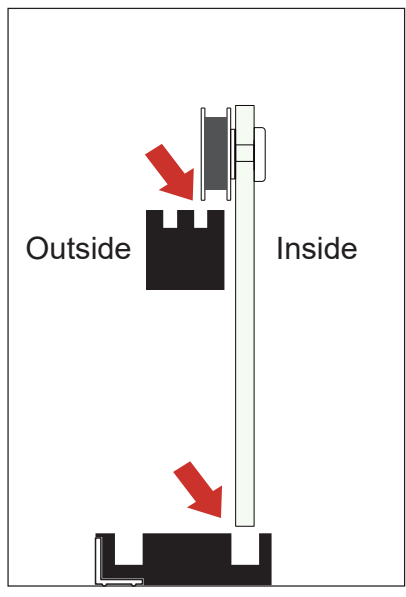
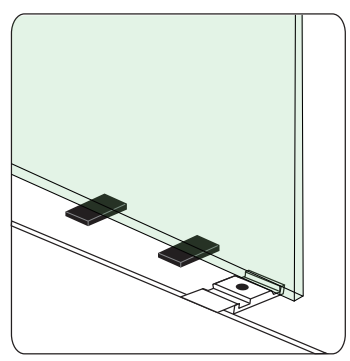

Installation Step 08

18  x2

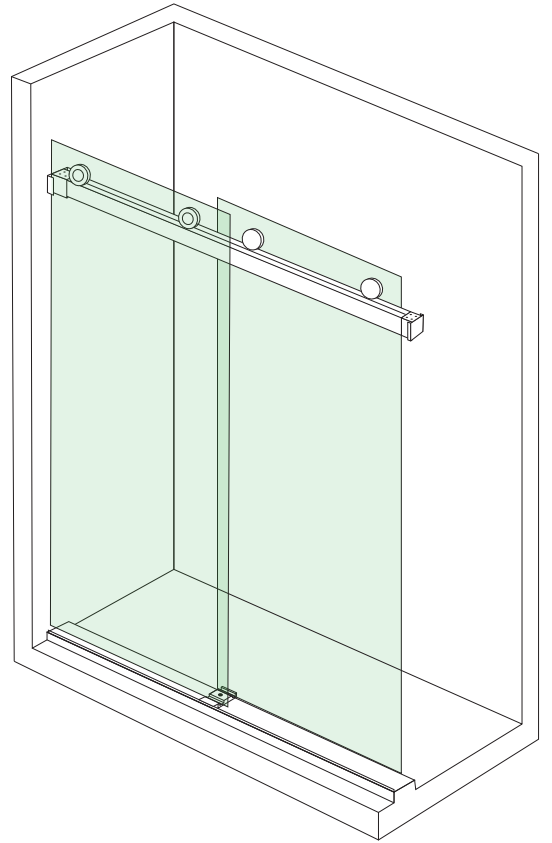
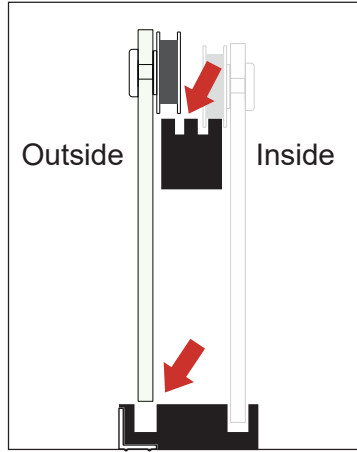
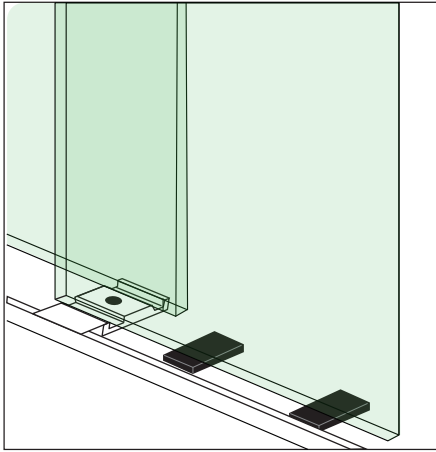

Installation Step 09

10  x4

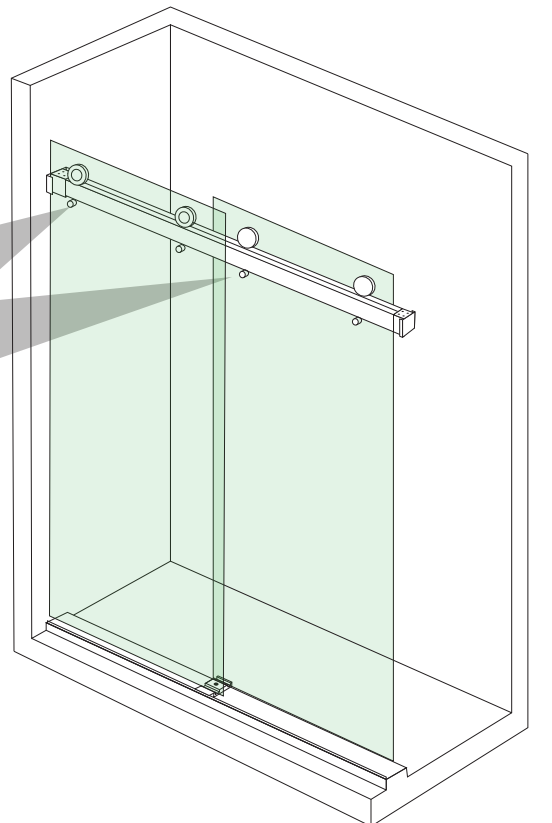
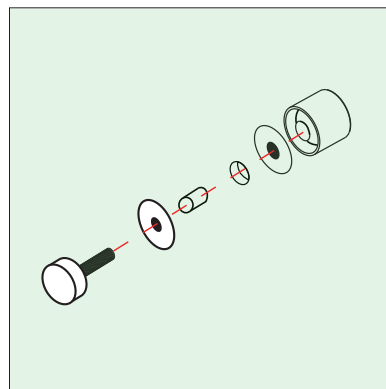
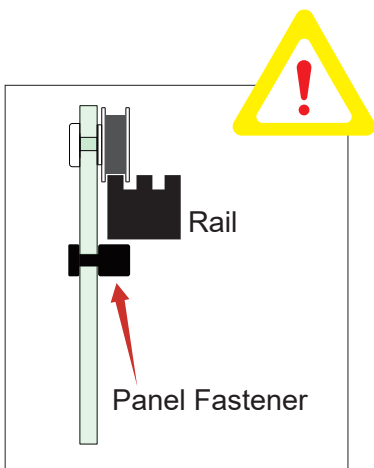

Installation Step 10

11  x4

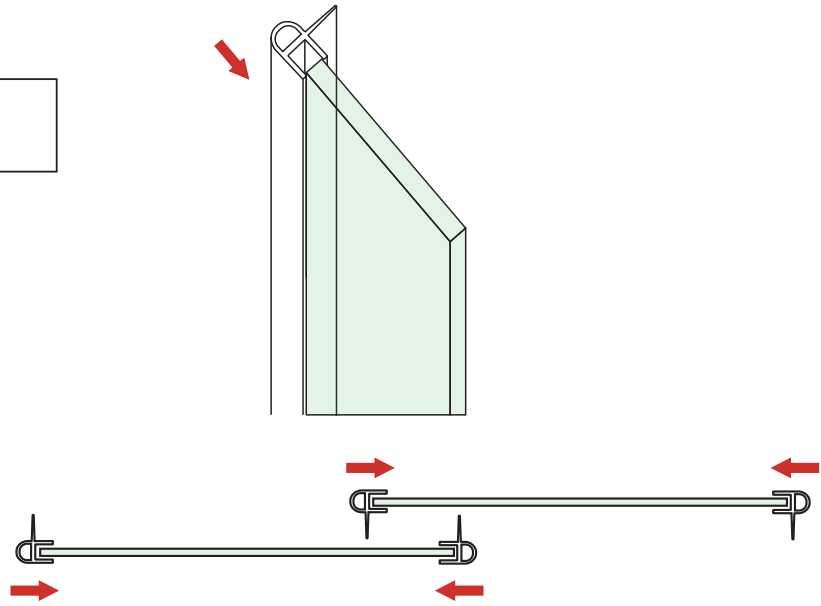
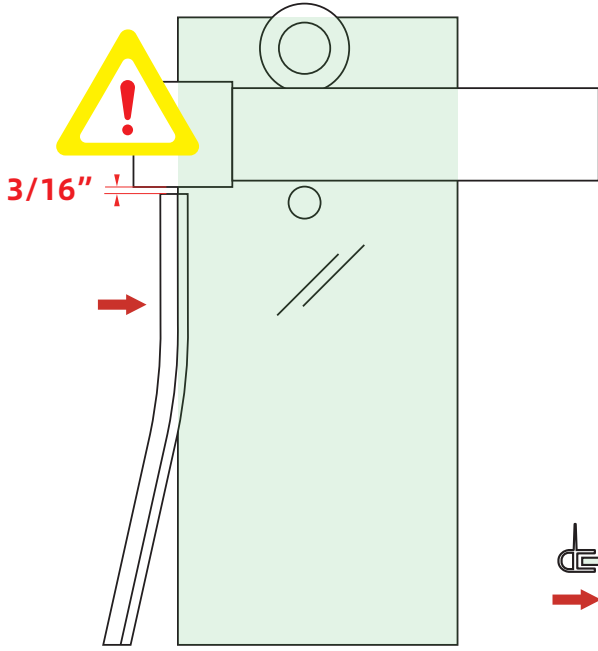

Installation Step 11

Adjust the Vertical and Horizontal

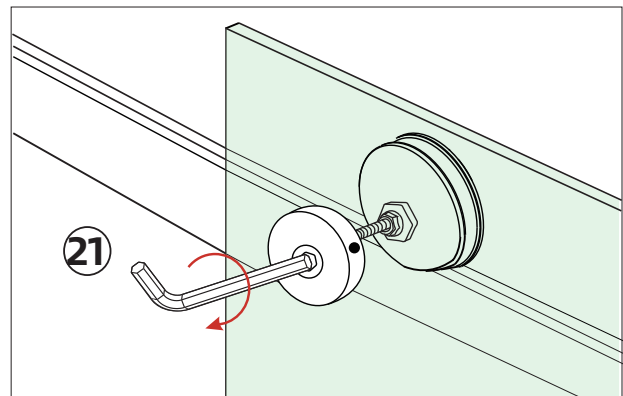
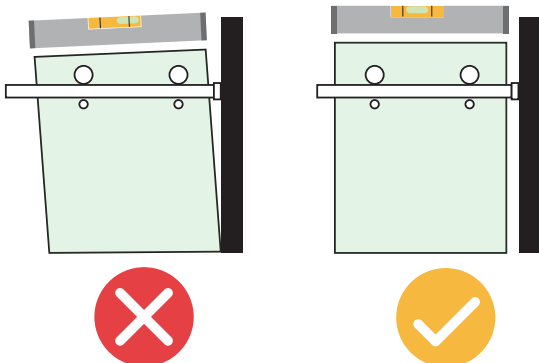
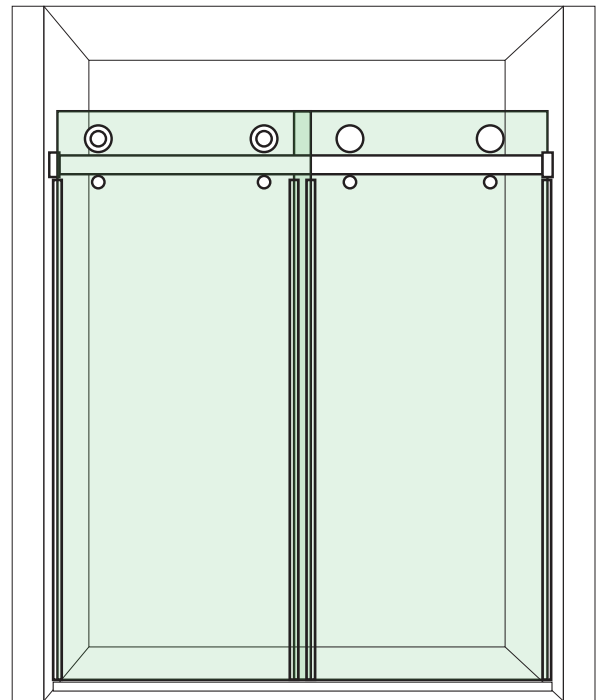
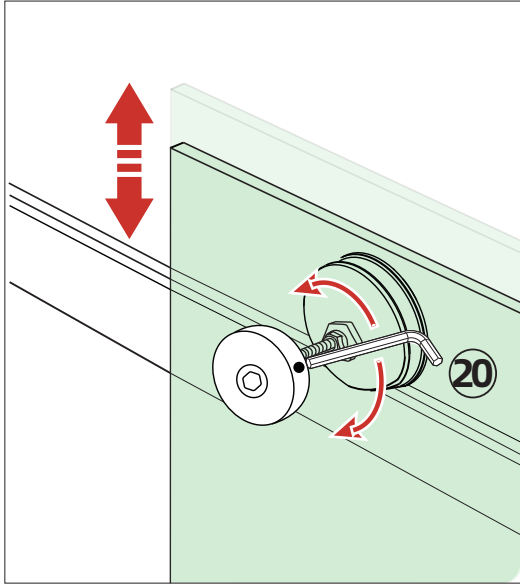

Screw Tightly After Adjustment

Installation Step 12

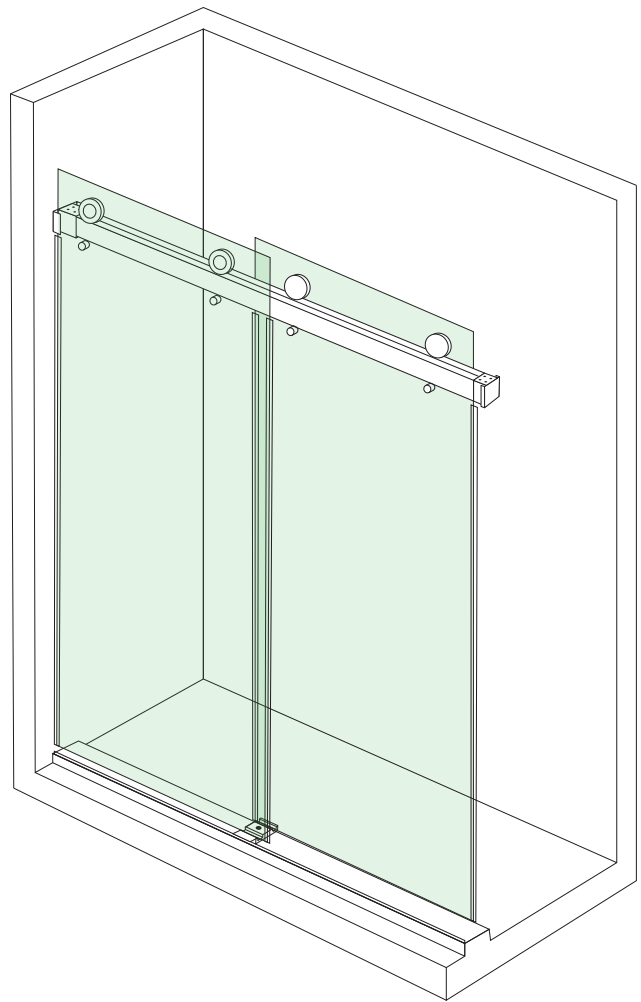
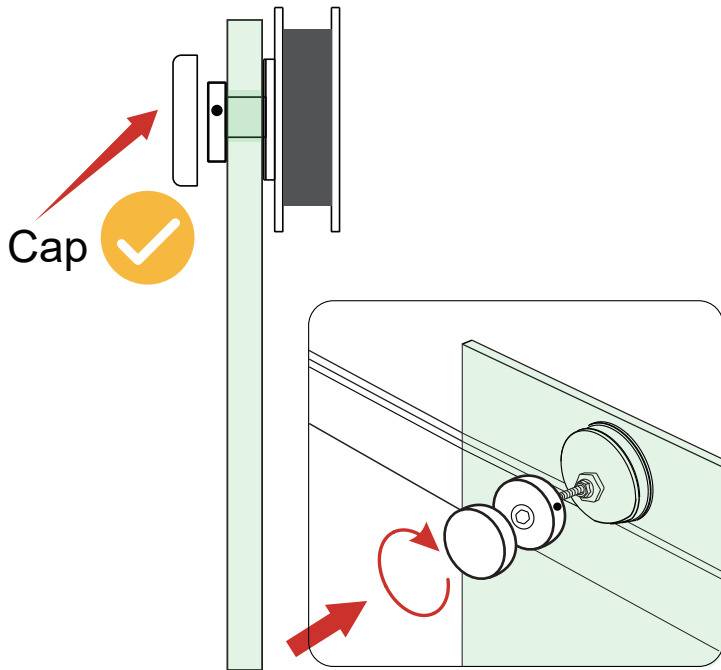

Installation Step 13

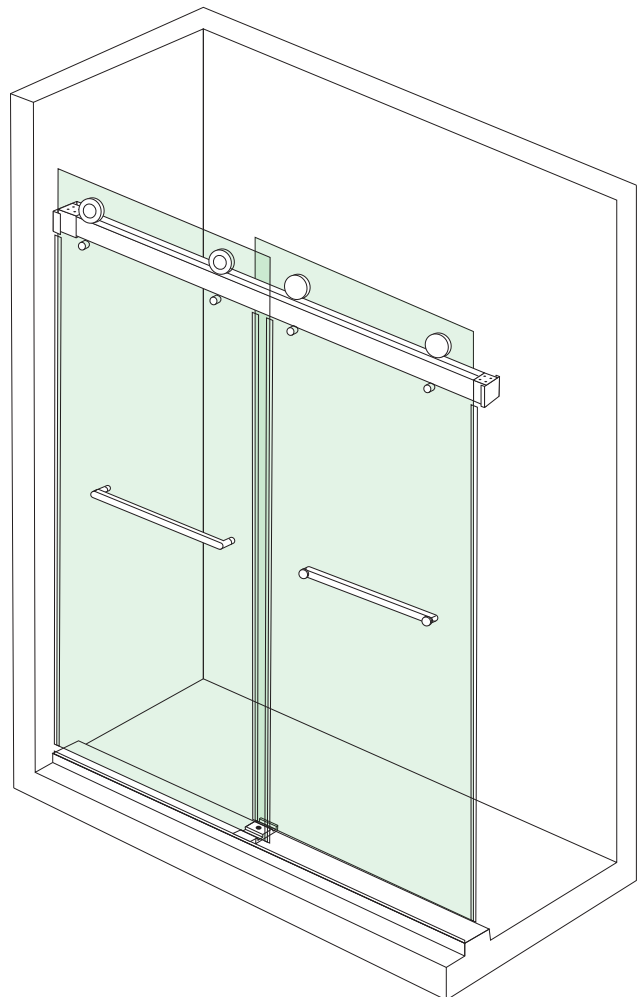
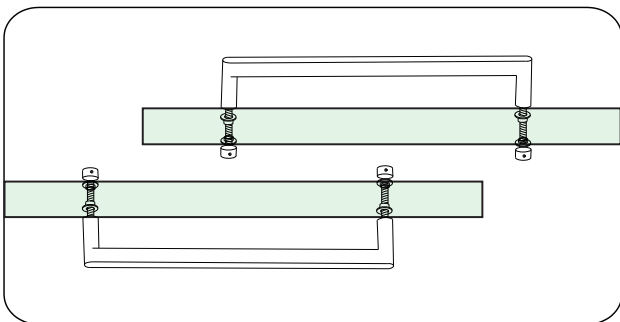
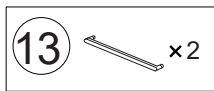

Installation Step 14

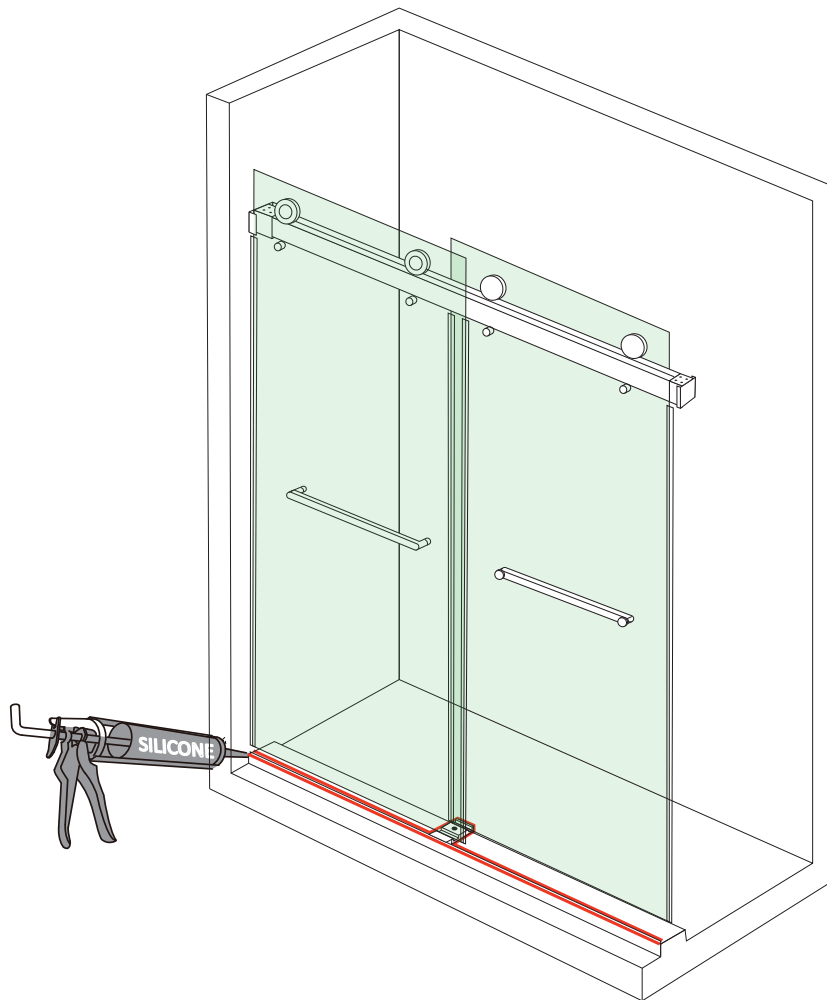

Do not use the shower enclosure for at least 24 hours in order to ENSURE the silicone sealant to cure fully.

Shower Door Maintenance And Care

- 1、 Shower door glass is double-sided easy-clean glass. Using moist soft cloth to wipe away surface water or stains For daily cleaning , reduce to use the cleaning agents to extend the easy-clean performance. Recommend to use soft cloth to clean the residual water stains on the glass and hardware after shower. Silicone squeegee is available.
- 2、 Do not use any sharp cleaning tools or cleaning agents with abrasive ingredients to clean the glass.
- 3、 Caustic cleaners should not be used, such as alcohol. Long-term use of corrosive cleaners will cause discoloration of the hardware.Reducing the use of cleaners will prolong the use of the hardware&glass appearance. You can use small amount of anhydrous ethanol or detergent to clean stubborn water stains or calculus on the hardware.

Warranty

ALL OTHER WARRANTIES EXPRESS OR IMPLIED INCLUDING ALL IMPLIED WARRANTIES OF MERCHANTABILITY OF FITNESS FOR A PARTICULAR PURPOSE ARE HEREBY DISCLAIMED. GETPRO IS NOT LIABLE FOR ANY INDIRECT, PUNITIVE, INCIDENTAL, CONSEQUENTIAL, SPECIAL OR SIMILAR DAMAGES INCLUDING, BUT NOT LIMITED TO, TIME AWAY FROM WORK, HOTELS AND/OR RESTAURANT MEALS, REMODELLING EXPENSES IN EXCESS OF DIRECT DAMAGES WHICH ARE DEFINITELY CAUSED EXCLUSIVELY BY GETPRO, LOST PROFITS OR REVENUE, INABILITY TO USE THE PRODUCT, OR ANY OTHER ASSOCIATED EQUIPMENT, THE COST OF SUBSTITUTE EQUIPMENT, AND ANY CLAIMS BY THIRD PARTIES RESULTING FROM THE USE OF THIS PRODUCT.

GETPRO PRODUCTS MUST BE INSTALLED BY A FULLY INSURED, LICENSED, PROFESSIONAL WHO SHALL FOLLOW THE INSTRUCTIONS PROVIDED BY GETPRO, SHOULD THE PRODUCT BE INSTALLED BY AN INDIVIDUAL WHO IS NOT A FULLY INSURED, LICENSED PROFESSIONAL, THIS SHALL VOID THE WARRANTY OF THE PRODUCT.

SHOULD A WARRANTY CLAIM ARISE AND EITHER PARTS, REPLACEMENT, OR REPAIR OF THE GETPRO PRODUCT IS NECESSARY, FULFILLING THE INITIAL WARRANTY CLAIM SHALL DISCHARGE GETPRO OF ANY FUTURE WARRANTY OBLIGATION. IF THE PURCHASER REFUSES THE WARRANTY SOLUTION PROVIDED BY GETPRO, THIS ACT SHALL VOID THE WARRANTY. UNDER BOTH INSTANCES, GETPRO WILL NOT BE HELD RESPONSIBLE FOR ANY COSTS ASSOCIATED WITH SERVICING THE WARRANTY.

NO PERSON MAY MAKE ANY REPRESENTATION, AFFIRMATION, OR WARRANTY OTHER THAN THOSE CONTAINED IN THIS WARRANTY, ANY AFFIRMATION, REPRESENTATION OR WARRANTY BY ANY PERSON WHO IS NOT A GETPRO EMPLOYEE SHALL NOT BE ENFORCEABLE AGAINST GETPRO.

GETPRO makes no representations about the quality, durability, or need for service or repair of its products other than the representations contained in this warranty. If you want a longer or more comprehensive warranty than the limited warranty that comes with this product, you should ask GETPRO about buying an extended warranty. This warranty gives you specific legal rights, and you may have other rights that vary from state to state. Some states do not allow the exclusion or limitation of incidental or consequential damages, and some states do not allow limitations on how long an implied warranty lasts, so the limitations or exclusions stated above may not apply and may vary from state to state.

The warranties stated herein apply only to the first purchaser of the Product and are not transferable. GETPRO reserves the right to request proof of purchase at the time any warranty claim is submitted to confirm that the Product falls within the scope of this limited product warranty.

OUT OF WARRANTY PRODUCT

GETPRO IS UNDER NO OBLIGATION, AT LAW OR OTHERWISE, TO PROVIDE YOU WITH ANY CONCESSIONS, INCLUDING REPAIRS. PRORATES

WARRANTY

LIMITED MANUFACTURER'S WARRANTY

- All parts and finishes of GETPRO products are warranted to the original consumer purchaser to be free from defects in material and workmanship for a period of two to five years [depending on the product and model: please check the product listing or email us at service@getprohome.com if you are unsure after the date of original retail purchase. Proof of the original purchase is required to obtain a remedy under this limited warranty.
- GETPRO recommends using a certified professional for all installation and repair of kitchen and bathroom fixtures.
- GETPRO will replace, free of charge, during the warranty period any part or finish that proves defective in material and/ or workmanship under normal installation, use and service. Replacement parts may be obtained by emailing us at service@getprohome.com
- This warranty is extensive in that it covers replacement of all defective parts and even finish, but these are the only two things that are covered. Labor charges and/or damage incurred in installation, repair, or replacement as well as any other kind of loss or damages are excluded.
- Proof of purchase (original sales receipt) from the original consumer purchaser must be made available to GETPRO for all warranty claims. This is the exclusive warranty by GETPRO, which does not make any other warranty of any kind including the implied warranty of Merchant ability. This warranty excludes all industrial, commercial and business usage whose purchasers are hereby extended a one-year limited warranty from the date at purchase, with all other terms of this warranty applying except the duration of the warranty.

NO ATTEMPT TO ALTER, MODIFY, OR AMEND THIS WARRANTY SHALL BE EFFECTIVE UNLESS AUTHORIZED IN WRITING BY AN OFFICER OF GETPRO

 service@getprohome.com

WHAT IS NOT COVERED UNDER THIS LIMITED WARRANTY

- Normal wear and tear, spills of food, liquid, grease accumulations or cosmetic damage.
- Damage due to accidents, misuse, physical force improper installation or operation, mishandling, neglect, fire, heat, water, humidity, liquids, insect infestation, or other intrusion.
- Products that have been repaired, altered or modified by anyone other than GETPRO or its authorized service representative.
- Damage caused by use of non-GETPRO accessories or misapplication Products whose serial numbers have been removed altered or rendered illegible.
- Products purchased, shipped from, used or serviced outside the United States. Canada and Mexico.
- Damage caused by acts of nature such as, but not limited to, lightning damage.
- Products returned without valid proof of purchase.
- Consumable parts such as light bulbs, metal, and charcoal filters.
- Any party's willful misconduct, negligence, misuse, abuse, accidents, neglect, improper operation, failure to maintain, improper or negligent installation, tampering, failure to follow operating instructions, mishandling, unauthorized service (including self-performed "fixing" or exploration of the product's internal workings).
- Use of corrosive or abrasive cleaning products.
- Cosmetic damages including scratches, dents, chips and other damage, unless such damage results from defects in materials and workmanship and is reported to GETPRO within 3 calendar days of delivery.
- Use of the Product in anything other than its normal customary and intended manner.
- A failure to comply with any applicable state, local city or county electrical, plumbing and/or building codes, regulations, or laws, including failure to install the product in strict conformity with local fire and building codes and regulations.
- In no event shall GETPRO have any liability or responsibility whatsoever for damage to surrounding property, including cabinetry, floors, ceilings, and other structures or objects around the product.

HOME SERVICES



INSTALLATION VIDEO

Missing Part or Defective?

Please Contact the Customer Service Team

✉ service@getprohome.com

☎ 626 679 3588